

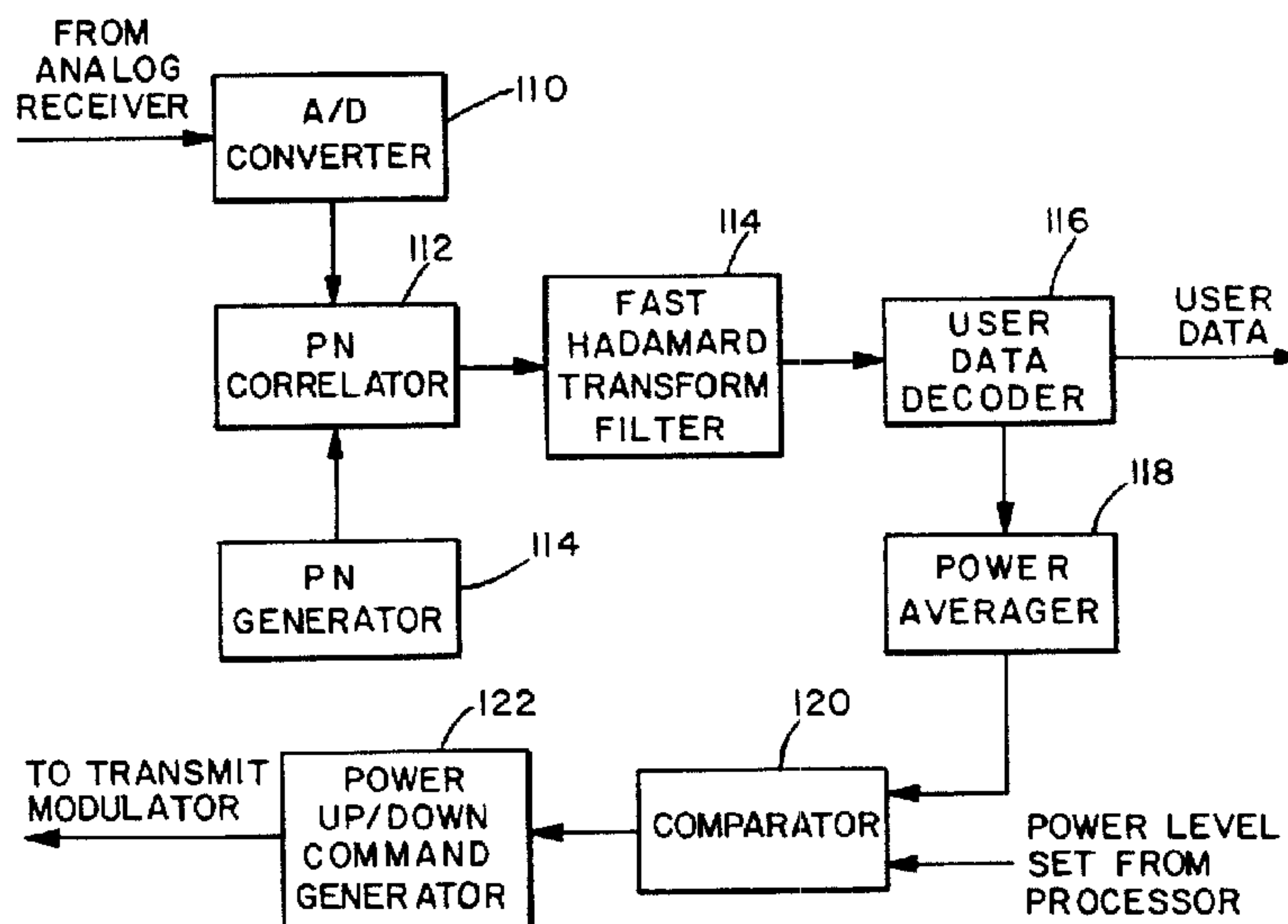

(86) Date de dépôt PCT/PCT Filing Date: 1990/11/05
 (87) Date publication PCT/PCT Publication Date: 1991/05/16
 (45) Date de délivrance/Issue Date: 2002/01/15
 (85) Entrée phase nationale/National Entry: 1992/05/06
 (86) N° demande PCT/PCT Application No.: US 90/06418
 (87) N° publication PCT/PCT Publication No.: WO 91/07037
 (30) Priorité/Priority: 1989/11/07 (433,031) US

(51) Cl.Int.⁵/Int.Cl.⁵ H04B 7/005, H04B 7/26
 (72) Inventeurs/Inventors:
 Wheatley, Charles E., III, US;
 Padovani, Roberto, US;
 Gilhousen, Klein S., US
 (73) Propriétaire/Owner:
 QUALCOMM INCORPORATED, US
 (74) Agent: SMART & BIGGAR

(54) Titre : METHODE ET DISPOSITIF POUR COMMANDER LA PUISSANCE D'EMISSION POUR SYSTEME DE TELEPHONIE MOBILE CELLULAIRE AMDC
 (54) Title: METHOD AND APPARATUS FOR CONTROLLING TRANSMISSION POWER IN A CDMA CELLULAR MOBILE TELEPHONE SYSTEM



(57) Abrégé/Abstract:

A power control system for a cellular mobile telephone system in which system users communicate information signals between one another via at least one cell-site using code division multiple access spread spectrum communication signals. The power control system controls transmission signal power for each cellular mobile telephone in the cellular mobile telephone system wherein each cellular mobile telephone has an antenna (70), a transmitter (84), and a receiver (72, 74) and each cell-site also has an antenna (52), a transmitter (62), and a receiver (54, 56). Cell-site transmitted signal power is measured as received at the mobile unit. Transmitted power at the mobile unit is adjusted by transmit power control units (76, 80) in an opposite manner with respect to increases and decreases in received signal power. A power control feedback scheme may also be utilized. At the cell-site communicating with the mobile unit, the mobile unit transmitted power is measured by the received power measurement unit (60) at the cell-site. A command signal is generated at the cell-site and transmitted to the mobile unit for further adjusting mobile unit transmitter power corresponding to deviations in the cell-site received signal power. The feedback scheme is used to further adjust the mobile unit transmitter power so that mobile unit transmitted signals arrive at the cell-site at a desired power level.



<p>(51) International Patent Classification 5 : H04L 27/30</p>	<p>A1</p>	<p>(11) International Publication Number: WO 91/07037 (43) International Publication Date: 16 May 1991 (16.05.91)</p>
<p>(21) International Application Number: PCT/US90/06418 (22) International Filing Date: 5 November 1990 (05.11.90) (30) Priority data: 433,031 7 November 1989 (07.11.89) US (71) Applicant: QUALCOMM, INC. [US/US]; 10555 Sorrento Valley Road, San Diego, CA 92121 (US). (72) Inventors: GILHOUSEN, Klein, S. ; 4039 Calgary Avenue, San Diego, CA 92122 (US). PADOVANI, Roberto ; 12634 Future Street, San Diego, CA 92130 (US). WHEATLEY, Charles, E., III ; 2208 Caminito del Barco, Del Mar, CA 92014 (US).</p>	<p>(74) Agents: BROWN, Carl, R. et al.; Brown, Martin, Haller and McClain, 110 West "C" Street, Suite 1300, San Diego, CA 92101 (US). (81) Designated States: AT (European patent), AU, BE (European patent), BG, BR, CA, CH (European patent), DE (European patent), DK (European patent), ES (European patent), FI, FR (European patent), GB (European patent), GR (European patent), HU, IT (European patent), JP, KP, KR, LU (European patent), NL (European patent), NO, RO, SE (European patent), SU. Published <i>With international search report.</i></p>	

(54) Title: METHOD AND APPARATUS FOR CONTROLLING TRANSMISSION POWER IN A CDMA CELLULAR MOBILE TELEPHONE SYSTEM

(57) Abstract

A power control system for a cellular mobile telephone system in which system users communicate information signals between one another via at least one cell-site using code division multiple access spread spectrum communication signals. The power control system controls transmission signal power for each cellular mobile telephone in the cellular mobile telephone system wherein each cellular mobile telephone has an antenna (70), a transmitter (84), and a receiver (72, 74) and each cell-site also has an antenna (52), a transmitter (62), and a receiver (54, 56). Cell-site transmitted signal power is measured as received at the mobile unit. Transmitted power at the mobile unit is adjusted by transmit power control units (76, 80) in an opposite manner with respect to increases and decreases in received signal power. A power control feedback scheme may also be utilized. At the cell-site communicating with the mobile unit, the mobile unit transmitted power is measured by the received power measurement unit (60) at the cell-site. A command signal is generated at the cell-site and transmitted to the mobile unit for further adjusting mobile unit transmitter power corresponding to deviations in the cell-site received signal power. The feedback scheme is used to further adjust the mobile unit transmitter power so that mobile unit transmitted signals arrive at the cell-site at a desired power level.

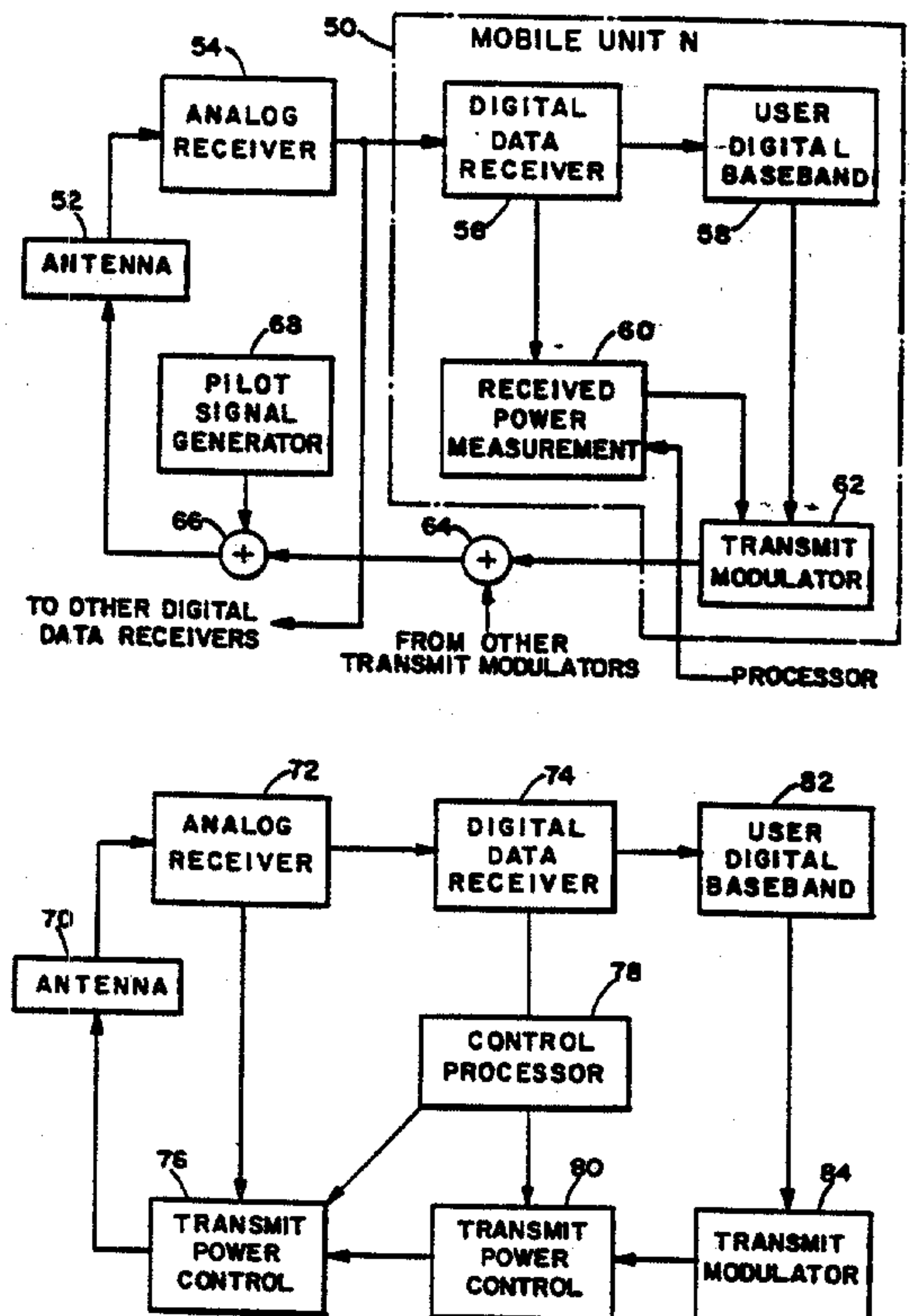

74769-4

1

METHOD AND APPARATUS FOR CONTROLLING
TRANSMISSION POWER IN A CDMA CELLULAR MOBILE
TELEPHONE SYSTEM

5 BACKGROUND OF THE INVENTION

I. Field of the Invention

The present invention relates to telephone systems. More specifically, the present invention relates to a novel and improved method and apparatus for controlling transmitter power
10 in a code division multiple access (CDMA) cellular mobile telephone system.

II. Description of the Related Art

The use of code division multiple access (CDMA) modulation techniques is one of several techniques for
15 facilitating communications in which a large number of system users are present. Although other techniques such as time division multiple access (TDMA) frequency division multiple access (FDMA) and AM modulation schemes such as amplitude companded single sideband (ACSSB) are known, CDMA has
20 significant advantages over these other techniques. The use of CDMA techniques in a multiple access communication system is disclosed in U.S. Patent Application Serial No. 06/921,261, filed October 17, 1986, entitled "SPREAD SPECTRUM MULTIPLE ACCESS COMMUNICATION SYSTEM USING SATELLITE OR TERRESTRIAL
25 REPEATERS", now U.S. Patent No. 4,901,307 assigned to the assignee of the present invention.

74769-4

1a

In the just mentioned patent, a multiple access technique is disclosed where a large number of mobile telephone system users each having a transceiver communicate through satellite repeaters or terrestrial base stations (also known as
5 cell-sites stations, or for short cell-sites) using code division multiple access (CDMA) spread spectrum communication signals. In using CDMA communications, the frequency spectrum can be reused multiple times thus permitting an increase in system user capacity. The use of CDMA results in a much higher
10 spectral efficiency than can be achieved using other multiple access techniques. In a CDMA system,

2072989

2

increases in system capacity may be realized by controlling the transmitter power of each mobile user so as to reduce interference to other system users.

5 In the satellite application of the CDMA communication techniques, the mobile unit transceiver measures the power level of a signal received via a satellite repeater. Using this power measurement, along with knowledge of the satellite transponder downlink transmit power level and the sensitivity of the mobile unit receiver, the mobile unit transceiver can estimate the path loss of the channel between the
10 mobile unit and the satellite. The mobile unit transceiver then determines the appropriate transmitter power to be used for signal transmissions between the mobile unit and the satellite, taking into account the path loss measurement, the transmitted data rate and the satellite receiver sensitivity.

15 The signals transmitted by the mobile unit to the satellite are relayed by the satellite to a Hub control system earth station. The Hub measures the received signal power from signals transmitted by each active mobile unit transceiver. The Hub then determines the deviation in the received power level from that which is necessary to maintain the
20 desired communications. Preferably the desired power level is a minimum power level necessary to maintain quality communications so as to result in a reduction in system interference.

The Hub then transmits a power control command signal to each mobile user so as to adjust or "fine tune" the transmit power of the mobile
25 unit. This command signal is used by the mobile unit to change the transmit power level closer to a minimum level required to maintain the desired communications. As channel conditions change, typically due to motion of the mobile unit, both the mobile unit receiver power measurement and the power control feedback from the Hub continually
30 readjust the transmit power level so as to maintain a proper power level. The power control feedback from the Hub is generally quite slow due to round trip delays through the satellite requiring approximately 1/2 of a second of propagation time.

35 One important difference between satellite or terrestrial base stations systems are the relative distances separating the mobile units and

the satellite or cell-site. Another important difference in the satellite versus the terrestrial system is the type of fading that occurs in these channels. Thus, these differences require various refinements in the approach to system power control for the terrestrial system.

5 In the satellite/mobile unit channel, i.e. the satellite channel, the satellite repeaters are normally located in a geosynchronous earth orbit. As such, the mobile units are all at approximately the same distance from the satellite repeaters and therefore experience nearly the same propagation loss. Furthermore, the satellite channel has a propagation
10 loss characteristic that follows approximately the inverse square law, i.e. the propagation loss is inversely proportional to the square of the distance between the mobile unit and the satellite repeater in use. Accordingly, in the satellite channel the variation in path loss due to distance variation is typically on the order of only 1-2 dB.

15 In contrast to the satellite channel, the terrestrial/mobile unit channel, i.e. the terrestrial channel, the distance between the mobile units and the cell sites can vary considerably. For example, one mobile unit may be located at a distance of five miles from the cell site while another mobile unit may be located only a few feet away. The variation in distance
20 may exceed a factor of one hundred to one. The terrestrial channel experiences a propagation loss characteristic as did the satellite channel. However, in the terrestrial channel the propagation loss characteristic corresponds to an inverse fourth-power law, i.e. the path loss is proportional to the inverse of the path distance raised to the fourth power.
25 Accordingly, path loss variations may be encountered which are on the order of over 80 dB in a cell having a radius of five miles.

 The satellite channel typically experiences fading that is characterized as Rician. Accordingly the received signal consists of a direct component summed with a multiply reflected component having
30 Rayleigh fading statistics. The power ratio between the direct and reflected component is typically on the order of 6-10 dB, depending upon the characteristics of the mobile unit antenna and the environment about the mobile unit.

 Contrasting the satellite channel with the terrestrial channel, the
35 terrestrial channel experiences signal fading that typically consists of the

2072989

4

Rayleigh faded component without a direct component. Thus, the terrestrial channel presents a more severe fading environment than the satellite channel where Rician fading is the dominant fading characteristic.

5 The Rayleigh fading characteristics in the terrestrial channel signal is caused by the signal being reflected from many different features of the physical environment. As a result, a signal arrives almost simultaneously at a mobile unit receiver from many directions with different transmission delays. At the UHF frequency bands usually employed for mobile radio communications, including those of cellular mobile
10 telephone systems, significant phase differences in signals traveling on different paths may occur. The possibility for destructive summation of the signals may result, with on occasion deep fades occurring.

Terrestrial channel fading is a very strong function of the physical position of the mobile unit. A small change in position of the mobile unit
15 changes the physical delays of all the signal propagation paths, which further results in a different phase for each path. Thus, the motion of the mobile unit through the environment can result in a quite rapid fading process. For Example, in the 850 MHz cellular radio frequency band, this fading can typically be fast as one fade per second per mile per hour of
20 vehicle speed. Fading on this order can be extremely disruptive to signals in the terrestrial channel resulting in poor communication quality. However, additional transmitter power can be used to overcome the problem of fading.

The terrestrial cellular mobile telephone system typically requires a
25 full-duplex channel to be provided in order to allow both directions of the telephone conversation to be simultaneously active such as provided by the conventional wired telephone system. This full-duplex radio channel is normally provided by using one frequency band for the outbound link, i.e. transmissions from the cell-site transmitter to the mobile unit
30 receivers. A different frequency band is utilized for the inbound link, i.e. transmissions from the mobile unit transmitters to the cell-site receivers. According, this frequency band separation allows a mobile unit transmitter and receiver to be active simultaneously without feedback or interference from the transmitter into the receiver.

35 The use of different frequency bands has significant implications in

the power control of the cell-site and mobile unit transmitters. Use of different frequency bands causes the multipath fading to be independent processes for the inbound and outbound channels. A mobile unit cannot simply measure the outbound channel path loss and assume that the same path loss is present on the inbound channel.

It is therefore, an object of the present invention to provide a novel and improved method and apparatus for controlling in the terrestrial channel transmitter power so as to overcome deleterious fading without causing unnecessary system interference which can adversely affect overall system capacity.

SUMMARY OF THE INVENTION

In a terrestrial CDMA cellular mobile telephone system, it is desirable that the transmitter power of the mobile units be controlled so as to produce at the cell site receiver a nominal received signal power from each and every mobile unit transmitter operating within the cell. Should all of the mobile unit transmitters within an area of coverage of the cell-site have transmitter power controlled accordingly the total signal power received at the cell-site would be equal to the nominal receiver power of the mobile unit transmitted signal multiplied by the number of mobile units transmitting within the cell. To this is added the noise power received at the cell-site from mobile units in adjacent cells.

The CDMA receivers of the cell-site respectively operate by converting a wideband CDMA signal from a corresponding one of the mobile unit transmitters into a narrowband digital information carrying signal. At the same time, other received CDMA signals that are not selected remain as wideband noise signals. The bit-error-rate performance of the cell-site receiver is thus determined by the ratio of the power of the desired signal to that of the undesired signals received at the cell-site, i.e., the received signal power in the desired signal transmitted by the selected mobile unit transmitter to that of the received signal power in undesired signals transmitted by the other mobile unit transmitters. The bandwidth reduction processing, a correlation process which results in what is commonly called "processing gain", increases the signal to noise

2072989

6

interference ratio from a negative value to a positive value thus allowing operation within an acceptable bit-error-rate.

In a terrestrial CDMA cellular mobile telephone system it is extremely desirable to maximize the capacity in terms of the number of simultaneous telephone calls that may be handled in a given system bandwidth. System capacity can be maximized if the transmitter power of each mobile unit is controlled such that the transmitted signal arrives at the cell-site receiver at the minimal signal to noise interference ratio which allows acceptable data recovery. If a signal transmitted by a mobile unit arrives at the cell-site receiver at a power level that is too low, the bit-error-rate may be too high to permit high quality communications. On the other hand if the mobile unit transmitted signal is at a power level that is too high when received at the cell site receiver, communication with this particular mobile unit will be acceptable. However, this high power signal acts as interference to other mobile unit transmitted signals that are sharing the same channel, i.e. bandwidth. This interference may adversely affect communications with other mobile units unless the total number of communicating mobile units is reduced.

The path loss of signals in the UHF frequency band of the cellular mobile telephone channel can be characterized by two separate phenomena, average path loss and fading. The average path loss can be described statistically by a log-normal distribution whose mean is proportional to the inverse fourth-power of the path distance, and whose standard deviation is approximately equal to 8 dB. The second phenomena is a fading process caused by multipath propagation of the signals which is characterized by a Rayleigh distribution. The average path loss, which is a log-normal distribution, can be considered to be the same for both the inbound and outbound frequency bands, as is for the conventional cellular mobile telephone systems. However, as mentioned previously Rayleigh fading is an independent phenomena for the inbound and outbound link frequency bands. The log-normal distribution of the average path loss is a relatively slow varying function of position. In contrast, the Rayleigh distribution varies relatively fast as a function of position.

In the present invention, a CDMA approach to multiple user access

in a cellular mobile telephone system is implemented. In such a system all the cell-sites in a region transmit a "pilot" signal of the same frequency and code. The use of a pilot signal in CDMA systems is well known. In this particular application, the pilot signal is used by the mobile units for
5 initial synchronization of the mobile unit receiver. The pilot signal is also used as a phase and frequency reference, and a time reference for demodulation of the digital speech signals transmitted by the cell-site.

In the present invention, each mobile unit estimates the path loss in signals transmitted from the cell-site to the mobile unit. In order to
10 make this signal path loss estimate, the power level of the cell-site transmitted signals, as received at the mobile unit, are measured. The mobile unit thus measures the pilot signal power as received from the cell-site to which the mobile unit is communicating. The mobile unit also measures the power level sum of all cell-site transmitted signals as
15 received at the mobile unit. The power level sum measurement as described in further detail later herein, is necessary to handle cases in which the mobile unit might temporarily obtain a better path to a more distant cell-site than to a normally preferred closest cell-site.

The outbound link path loss estimate is filtered using a non-linear
20 filter. The purpose of the non-linearity in the estimation process is to permit a rapid response to a sudden improvement in the channel while only allowing a much slower response to a sudden degradation in the channel. The mobile unit in response to a sudden improvement in the channel thus suddenly reduces mobile unit transmitter transmit power.

Should the channel for one mobile unit suddenly improve, then
25 the signal as received at the cell-site from this mobile unit will suddenly increase in power. This sudden increase in power causes additional interference to all signals sharing the same wideband channel. A rapid response to the sudden improvement will thus reduce system
30 interference.

A typical example of a sudden improvement in the channel occurs when a mobile unit is moving through an area that is shadowed by a large building or other obstruction and then drives out of the shadow. The channel improvement, as a result of the vehicle movement, can take
35 place on the order of a few tens of milliseconds. As the mobile unit drives

2072989

out of the shadow, the outbound link signal as received by the mobile unit will suddenly increase in strength.

The outbound link path loss estimate at the mobile unit is used by the mobile unit to adjust the mobile unit transmitter power. Thus, the stronger the received signal, the lower the mobile unit transmitter power will be. Reception of a strong signal from the cell-site indicates that the mobile unit is either close to the cell-site or else an unusually good path to the cell-site exists. Reception of a strong signal means that a relatively smaller mobile unit transmitter power level is required in nominal received power at the cell-site the mobile unit.

In the case where there is a temporary but yet sudden degradation in the channel it is desirable that a much slower increase in mobile unit transmitter power be permitted. This slow increase in mobile unit transmitter power is desired so as to prohibit an unnecessarily rapid increase in mobile unit transmit power which increases the interference to all other mobile units. Thus a temporary degradation in one mobile unit channel will be tolerated in order to prevent a degradation of all mobile unit channels.

In the case of a sudden degradation in the channel, the non-linear filter prevents the mobile transmitter power from being increased at a high rate in response to the sudden decrease in signal power in signals received at the mobile unit. The rate of increase of the mobile unit transmitter transmit power must generally be limited to the rate of a closed loop power adjustment command transmitted from the cell-site, as described below, can reduce the mobile unit transmitter transmit power. Using the cell-site generated power adjustment commands, the mobile unit transmitter power will be prevented from being increased to a level significantly higher than the level required for communications, particularly when a sudden channel degradation occurs in only the outbound link path and not in the inbound link path.

It should be noted that it is undesirable to simply use a slow response on the mobile unit transmitter power control in an attempt to separate the fast Rayleigh fading from the slow fading due to distance and terrain. A slow response in the mobile unit transmitter power control is undesirable because the possibility of sudden improvements and fades

that affect the inbound and outbound channels equally. If the response to a sudden improvement were to be slowed down by a filter, then there would be frequent occasions when the mobile unit transmitter power would be quite excessive and cause interference to all other mobile users.

5 Thus the present invention uses a two-time constant, non-linear approach in estimating the path loss.

In addition to measuring the received signal strength in the mobile unit, it is also desirable for the processor in the mobile unit to know the cell-site transmitter power and antenna gain (EIRP), the cell-site G/T
10 (receive antenna gain G divided by receiver noise level T) the mobile unit antenna gain, and the number of calls active at this cell-site. This information allows the mobile unit processor to properly compute the reference power level for the local power setting function. This computation is done by calculating the cell-site to mobile link power
15 budget, solving for the path loss. This path loss estimate is then used in the mobile cell-site link budget equation, solving for the mobile unit transmit power required to produce a desired signal level. This capability allows the system to have cell-sites with differing EIRP levels to correspond to the size of the cells. For example, a small radius cell need
20 not transmit with as high a power level as a large radius cell. However, when the mobile unit is a certain distance from a low power cell, it would receive a weaker signal than from a high power cell. The mobile unit would respond with a higher transmit power than would be necessary for the short range. Hence, the desirability of having each cell-site transmit
25 information as to its characteristics for power control.

The cell-site transmits information such as cell-site EIRP, G/T and number of active calls on a cell-site setup channel. The mobile unit receives this information when first obtaining system synchronization and continues to monitor this channel when idle for pages for calls
30 originated within the public telephone switching network intended for the mobile unit. The mobile unit antenna gain is stored in a memory in the mobile unit at the time the mobile unit is installed in the vehicle.

As mentioned previously, mobile unit transmitter power is also controlled by a signal from the cell-site. Each cell-site receiver measures
35 the strength of the signal, as received at the cell-site, from each mobile

2072989

10

unit to which the cell-site is in communication with. The measured signal strength is compared to a desired signal strength level for that particular mobile unit. A power adjustment command is generated and sent to the mobile unit in the outbound link data, or voice channel, addressed to that mobile unit. In response to the cell-site power adjustment command, the mobile unit increases or decreases the mobile unit transmitter power by a predetermined amount, nominally 1 dB.

The power adjustment command is transmitted by the cell-site transmitter at a relatively high rate, typically on the order of about one command every millisecond. The rate of transmission of the power adjustment command must be high enough to permit Rayleigh fading on the inbound link path to be tracked. It is further desirable for the outbound link path Rayleigh fading impressed on the inbound link path signal to be tracked. One command per millisecond is adequate to track the fading processes for vehicle speeds in the range of 25-50 miles per hour for 850 MHz band mobile communications. It is important that the latency in determining the power adjustment command and the transmission thereof be minimized so that channel conditions will not change significantly before the mobile unit receives and responds to the signal.

In summary, to account for the independence of the two Rayleigh fading paths (inbound and outbound), the mobile unit transmitter power is controlled by the power adjustment command from the cell-site. Each cell-site receiver measures the received signal strength from each mobile unit. The measured signal strength is compared to the desired signal strength for that mobile unit and a power adjustment command is generated. The power adjustment command is sent to the mobile unit in the outbound data or voice channel addressed to that mobile unit. This power adjustment command is combined with the mobile unit one way estimate to obtain the final value of the mobile unit transmitter power.

The power adjustment command signal is transmitted, in an exemplary embodiment, by overwriting one or more user data bits every millisecond. The modulation system employed in CDMA systems is capable of providing correction coding for user data bits. The overwrite by the power adjustment command is treated as a channel bit error or erasure

and corrected by the error correction as decoded in the mobile unit receiver. Error correction coding on the power adjustment command bits in many cases may not be desirable because of the resulting increased latency in reception and response to the power adjustment command. It is
5 also envisioned that time division multiplexing for transmission of the power adjustment command bits may be used without overwriting user data channel symbols.

The cell-site controller or processor can be used to determine the desired signal strength, as received at the cell-site, for signals transmitted
10 by each mobile unit. The desired signal strength level values are provided to each of the cell-site receivers. The desired signal strength value is used for comparing with a measured signal strength value for generating the power adjustment command.

A system controller is utilized to command each cell-site processor
15 as to the value of desired signal strength to use. The nominal power level can be adjusted up or down to accommodate variations in the average conditions of the cell. For example, a cell-site positioned in an unusually noisy location or geographic region might be allowed to use a higher than normal inbound power level. However, such a higher power level for in-
20 cell operation will result in higher levels of interference to immediate neighbors of this cell. This interference can be compensated for by allowing the neighbor cells a small increase in inbound link power. Such an increase in inbound power in neighboring cells would be smaller than
25 noise environment cell. It is further understood that the cell-site processor may monitor the average bit-error-rate. This data may be used by the system controller to command the cell-site processor to set an appropriate inbound link power level to assure acceptable quality communications.

30 It is also desirable to provide a means for controlling the relative power used in each data signal transmitted by the cell-site in response to control information transmitted by each mobile unit. The primary reason for providing such control is to accommodate the fact that in certain locations, the outbound channel link from the cell-site to the mobile unit
35 may be unusually disadvantaged. Unless the power being transmitted to

2072989

12

this mobile is increased, the quality may become unacceptable. An example of such a location is a point where the path loss to one or two neighboring cells is nearly the same as the path loss to the cell-site communicating with the mobile unit. In such a location, the total interference would be increased by three times over the interference seen by the mobile unit at a point relatively close to its cell-site. In addition, the interference coming from these neighboring cell-sites will not fade in unison with the desired signal as would be the case for interference coming from the desired cell-site. This situation may require 3-4 dB additional signal power to achieve adequate performance.

In another situation, the mobile unit may be located where several strong multi-path signals arrive, resulting in larger than normal interference. In such a situation, increasing the power of the desired signal relative to the interference may allow acceptable performance. At other times, the mobile unit may be located where the signal-to-interference ratio is unusually good. In such a case, the cell-site could transmit the desired signal using a lower than normal transmitter power, reducing interference to other signals being transmitted by the system.

To achieve the above objectives, the preferred embodiment includes a signal-to-interference measurement capability within the mobile unit receiver. This measurement is performed by comparing the power of the desired signal to the total interference and noise power. If the measured ratio is less than a predetermined value, the mobile transmits a request to the cell-site for additional power in cell-site transmissions. If the ratio exceeds the predetermined value the mobile unit transmits a request for a reduction in power.

The cell-site receives the power adjustment requests from each mobile and responds by adjusting the power allocated to the corresponding cell-site transmitted signal by a predetermined amount. The adjustment would usually be small, on the order of 0.5 dB, or 12%. The rate of change of power may be somewhat slower than that used for the inbound link from the mobile unit to cell-site, perhaps once per vocoder frame, or nominally once per 15 milliseconds. The dynamic range of the adjustment would also be limited to 4 dB less than nominal to about 6 dB greater than nominal.

74769-4

13

The cell-site must also consider the power demands being made on it by all the mobiles in deciding whether to comply with the requests of any particular mobile. For example, if the cell-site is loaded to capacity, requests for additional power might be granted but only by 6% or less, instead of the normal 12%. In this regime, a request for a reduction in power would still be granted at the normal 12% change.

BRIEF DESCRIPTION OF THE DRAWINGS

10 The present invention may be summarized according to one aspect as in a cellular mobile telephone system in which system users communicate information signals between one another via at least one cell-site using code division multiple access (CDMA) spread spectrum communication
15 signals, a power control system for controlling transmission signal power for each mobile telephone in said cellular mobile telephone system, wherein each mobile telephone has an antenna, transmitter and receiver and each cell-site has an antenna, at least one transmitter and at least one
20 receiver, said power control system comprising: at least one first power measurement means, each coupled to a respective mobile telephone receiver, for measuring signal power in CDMA communication signals received by said respective mobile telephone receiver; at least one first power
25 adjustment means, each coupled to a respective mobile telephone transmitter and corresponding first power measurement means, said first power adjustment means responsive to decreases and increases in power measurements of said corresponding first power measurement means with
30 respect to a first predetermined power level, for

74769-4

13a

respectively increasing and decreasing transmission signal power of said corresponding mobile telephone transmitter; at least one second power measurement means, each coupled to a respective cell-site receiver, for measuring signal power in
5 each CDMA communication signal directed to said respective cell-site receiver from a corresponding mobile telephone transmitter in communication therewith; at least one power adjustment command generator means, each coupled to a respective cell-site transmitter and corresponding second
10 power measurement means, for generating power adjustment commands corresponding to deviations in power measurements of said corresponding second power measurement means from a second predetermined power level, said respective cell-site transmitter transmitting said power adjustment commands; and
15 at least one second power adjustment means, each coupled to a respective mobile telephone receiver and corresponding transmitter, said second power adjustment means responsive to said power adjustment commands directed to said respective mobile telephone receiver, for adjusting
20 transmission signal power of said corresponding mobile telephone transmitter.

According to another aspect the invention provides an apparatus for controlling transmission signal power in a cellular mobile telephone in communications with at least
25 one cell-site station using code division multiple access (CDMA) spread spectrum communication signals, said cellular mobile telephone having an antenna coupled to a transmitter and a receiver, said transmitter for generating and transmitting a CDMA carrier signal according to an assigned
30 spreading function modulated by a mobile user input information signal, said receiver for receiving CDMA communication signals and spectrum processing said received CDMA communi-

74769-4

13b

cation signals according to an assigned spreading function so as to recover a mobile user output information signal intended for a user of said cellular mobile telephone, said cell-site station communicating power adjustment commands in CDMA communication signals intended for said cellular mobile telephone with said receiver providing an output of said power adjustment commands, said apparatus comprising: measurement means, operatively coupled to said receiver, for measuring combined signal power in contemporaneously received CDMA communication signals and providing a measurement signal indicative of measured signal power; adjustment means, operatively coupled to said transmitter, for receiving said measurement signal, varying transmitter signal power in opposite correspondence to variations in measured signal power about a predetermined power level; and additional adjustment means, operatively coupled to said receiver and transmitter, for receiving said power adjustment commands, and varying transmitter signal power in correspondence thereto.

According to yet another aspect the invention provides a transceiver having a receiver for receiving and demodulating an outbound information containing spread spectrum signal as transmitted by a base station to an intended user, and a transmitter for transmitting an inbound information containing spread spectrum signal to said base station for transfer to another intended user, said transceiver having a power control system for controlling transmitter signal power of said inbound spread spectrum signal at a substantially constant level as received at said base station wherein said base station measures signal power of said inbound spread spectrum signal, generates power adjustment commands according to variations in said measured

74769-4

13c

signal power of said inbound spread spectrum signal with respect to a predetermined received inbound spread spectrum signal power level and transmits said power level adjustment commands in said outbound spread spectrum signal, said power

5 control system comprising: control processor means coupled to said receiver, for receiving from said receiver said power adjustment commands transmitted in said outbound spread spectrum signal, accumulating values corresponding to said power adjustment commands with respect to a

10 predetermined closed loop power level value, and generating a corresponding closed loop power level control signal, said control processor means further for generating an open loop power level signal indicative of a predetermined open loop power level value; first amplifier means, operatively

15 coupled to said transmitter, for receiving said closed loop power level control signal from said control processor means, and amplifying said inbound spread spectrum signal at a first gain determined by said closed loop power level control signal for transmission by said transmitter;

20 automatic gain control means, coupled to said receiver, for measuring signal power of outbound spread spectrum signals received by said receiver, and providing a corresponding power measurement signal; comparator means for receiving and comparing said power measurement signal and said open loop

25 power level signal, and providing a corresponding open loop power level control signal; and second amplifier means, operatively coupled to said transmitter, for receiving said open loop power level control signal, and amplifying said inbound spread spectrum signal at a second gain determined

30 by said open loop power level control signal.

According to still another aspect the invention provides a system for controlling transmission power, at a

74769-4

13d

substantially constant level, of a first transceiving
capable of transmitting information signals of a first user,
using spread spectrum communication signals, to a second
transceiver for transfer to a second user, and said first
5 transceiver further capable of extracting information
signals of a second user transmitted to said first
transceiver by said second transceiver, also using spread
spectrum communication signals, said system comprising: open
loop power control means operatively coupled to said first
10 transceiver for controlling signal power of said first
transceiver transmitted spread spectrum communication
signals in opposite correspondence to variations in signal
power of first transceiver received spread spectrum
communication signals; and closed loop power control means
15 operatively coupled to said first and second transceiver for
further controlling signal power of said first transceiver
transmitted spread spectrum communication signals in
opposite correspondence to variations in signal power of
second transceiver received spread spectrum communication
20 signals.

According to a further aspect the invention
provides a method for controlling transmission power, at a
substantially constant level, of a first transceiver capable
of communicating information signals of a first user, using
25 spread spectrum communication signals, to a second
transceiver for transfer to a second user and said first
transceiver capable of extracting information signals of a
second user communicated to said first transceiver by said
second transceiver using said spread spectrum communication
30 signals, said method comprising the steps of: controlling
signal power of said first transceiver transmitted spread
spectrum communication signals in opposite correspondence to

74769-4

13e

variations in signal power of first transceiver received
spread spectrum communication signals; and controlling
signal power of said first transceiver transmitted spread
spectrum communication signals in opposite correspondence to
5 variations in signal power of second transceiver received
spread spectrum communication signals.

According to a further aspect the invention
provides in a cellular mobile telephone system in which
system users communicate information signals between one
10 another via at least one cell-site using code division
multiple access (CDMA) spread spectrum communication
signals, a method for controlling transmission signal power
for each mobile telephone in said cellular mobile telephone
system, wherein each mobile telephone has an antenna,
15 transmitter and receiver, and each cell-site has an antenna,
at least one transmitter and at least one receiver, said
method comprising the steps of: measuring signal power in
CDMA communication signals received by each respective
mobile telephone receiver; varying transmission signal power
20 of each corresponding mobile telephone transmitter in
inverse proportion to variations in corresponding mobile
telephone power measurements with respect to a first
predetermined power level; measuring signal power in each
CDMA communication signal received at each respective cell-
25 site receiver as transmitted from a corresponding mobile
telephone transmitter in communication therewith; generating
power adjustment commands corresponding to deviations in
corresponding cell-site power measurements from a second
predetermined power level; transmitting said power
30 adjustment commands along with said information signals from
each respective cell-site to a corresponding mobile
telephone in communication therewith; receiving at each

74769-4

13f

respective mobile telephone receiver said power adjustment
commands corresponding thereto; and adjusting transmission
signal power of each corresponding mobile telephone
transmitter in correspondence to said power adjustment
5 commands directed to said respective mobile telephone
receiver.

According to a final aspect the invention provides
a method for controlling transmission signal power in a
cellular mobile telephone in communications with at least
10 one cell-site station using code division multiple access
(CDMA) spread spectrum communication signals, said cellular
mobile telephone having an antenna coupled to a transmitter
and a receiver, said transmitter for generating and
transmitting a CDMA carrier signal according to an assigned
15 spreading function modulated by a mobile user input informa-
tion signal, said receiver for receiving CDMA communication
signals and spectrum processing said received CDMA communi-
cation signals according to an assigned spreading function
so as to recover a mobile user output information signal
20 intended for a user of said cellular mobile telephone, said
cell-site station communicating power control commands in
CDMA communication signals intended for said cellular mobile
telephone with said receiver processing said received power
control commands and providing an output of said power
25 control commands, said method comprising the steps of:
measuring combined signal power in contemporaneously
received CDMA communication signals and providing a
measurement signal indicative of said combined signal power;
varying transmitter signal power in inverse proportion to
30 variations in measured signal power about a predetermined
power level; and varying transmitter signal power in
correspondence to received power adjustment commands.

74769-4

13g

The features and advantages of the present invention will become more apparent from the detailed description set forth below when taken in conjunction with the drawings in which like reference characters correspond
5 throughout and wherein:

Figure 1 is a schematic overview of an exemplary mobile cellular telephone system;

Figures 2A-2D illustrate, in a series of graphs, mobile unit received signal strength and transmit power as a
10 function of distance;

Figure 3 is a block diagram of a cell-site with particular reference to the power control features of the present invention;

Figure 4 is a block diagram of the mobile unit
15 with particular reference to the power control features of the present invention;

Figure 5 is a block diagram illustrating in further detail the power control features of the mobile unit of Figure 4; and

20 Figure 6 is a block diagram illustrating in further details the power control features of the cell-site of Figure 3.

DETAILED DESCRIPTION OF THE PREFERRED EMBODIMENTS

An exemplary terrestrial cellular mobile telephone
25 system in which the present invention is embodied is illustrated in Figure 1. The system illustrated in Figure 1 utilizes CDMA modulation techniques in communications between the system mobile user, and the cell-sites.

74769-4

13h

Cellular systems in large cities may have hundreds of cell-site stations serving hundreds of thousands of mobile telephones. The use of CDMA

2072989

14

techniques readily facilitates increases in user capacity in systems of this size as compared to conventional FM modulation cellular systems.

In Figure 1, system controller and switch 10, typically includes appropriate interface and processing hardware for providing system control information to the cell-sites. Controller 10 controls the routing of telephone calls from the public switched telephone network (PSTN) to the appropriate cell-site for transmission to the appropriate mobile unit. Controller 10 also controls the routing of calls from the mobile units via at least one cell-site to the PSTN. Controller 10 may direct calls between mobile users via the appropriate cell-site stations since such mobile units do not typically communicate directly with one another.

Controller 10 may be coupled to the cell-sites by various means such as dedicated telephone lines, optical fiber links or by radio frequency communications. In Figure 1, two exemplary cell-sites, 12 and 14, along with two exemplary mobile units 16 and 18 which include cellular telephones are illustrated. Arrows 20a-20b and 22a-22b respectively define the possible communication links between cell-site 12 and mobile units 16 and 18. Similarly, arrows 24a-24b and arrows 26a-26b respectively define the possible communication links between cell-site 14 and mobile units 18 and 16. Cell-sites 12 and 14 normally transmit using equal power.

Mobile unit 16 measures the total received power in pilot signals transmitted by cell-sites 12 and 14 upon path 20a and 26a. Similarly, mobile unit 18 measures the total received power in pilot signal as transmitted by cell-sites 12 and 14 upon paths 22a and 24a. In each of mobile units 16 and 18, pilot signal power is measured in the receiver where the signal is a wideband signal. Accordingly, this power measurement is made prior to correlation of the received signal with a pseudonoise (PN) spectrum spreading signal.

When mobile unit 16 is closer to cell-site 12, the received signal power will be dominated by the signal traveling path 20a. When mobile unit 16 is nearer to cell-site 14, the received power will be dominated by the signal traveling on path 26a. Similarly, when mobile unit 18 is closer to cell-site 14, the received power will be dominated by the signal on path 24a. When mobile unit 18 is closer to cell-site 12, the received power will be dominated by the signal traveling on path 22a.

2072989

15

Each of mobile units 16 and 18 uses the resultant measurement, together with knowledge of the cell-site transmitter power and the mobile unit antenna gain to estimate the path loss to the closest cell-site. The estimated path loss, together with knowledge of the mobile antenna gain and the cell-site G/T is used to determine the nominal transmitter power required to obtain the desired carrier-to-noise ratio in the cell-site receiver. The knowledge by the mobile units of the cell-site parameters may be either fixed in memory or transmitted in cell-site information broadcast signals, setup channel, to indicate other than nominal conditions for a particular cell-site.

As a result of the determination of the mobile unit nominal transmit power, in the absence of Rayleigh fading and assuming perfect measurements, the mobile unit transmitted signals will arrive at the nearest cell-site precisely at the desired carrier-to-noise ratio. Thus the desired performance will be obtained with the minimum amount of mobile unit transmitter power. The minimization of the mobile unit transmitted power is important in a CDMA system because each mobile unit causes interference to every other mobile unit in the system. In minimizing the mobile unit transmitter power, system interference will be held to a minimum, thus allowing additional mobile users to share the frequency band. Accordingly, system capacity and spectral efficiency is maximized.

Figure 2A illustrates the effect of both Rayleigh fading as a function of distance on the strength of the cell-site transmitted signal as received at a mobile unit. The average path loss, indicated by curve 30, is determined primarily by the fourth-power of the distance between the cell-site and the mobile unit, and by the shape of the terrain between them. As distance increases between the mobile unit and the cell-site, signal power decreases as received at the mobile unit for a constant power transmitted cell-site signal. The average path loss is the same for both directions of the link, and typically exhibits a log-normal distribution about the average path loss.

In addition to the slowly varying log-normal average path loss, the rapid fading up and down around the average path loss is caused by the existence of multiple path signal propagation. The signals arrive from

2072989

16

these multiple paths in random phase and amplitude, resulting in the characteristic Rayleigh fading. Curve 32, as illustrated in Figure 2A, represents the variation in signal path loss as a result of Rayleigh fading. The Rayleigh fading is typically independent for the two directions of the cell-site/mobile unit communication link, i.e. outbound and inbound channels. For example, when the outbound channel is fading, the inbound channel is not necessarily fading at the same time.

Figure 2B illustrates the mobile unit transmitter power adjusted to correspond to the link path signal strength of Figure 2A. In Figure 2B, curve 34 represents the desired average transmit power corresponding to the average path loss of curve 30 of Figure 2A. Similarly, curve 36 corresponds to the mobile unit transmitter power responding to the Rayleigh fading as represented by curve 32 of Figure 2A. As the Rayleigh faded signal, curve 32 of Figure 2A, decreases in signal strength, rapid increases in transmitter power result. These rapid upward excursions of transmitter power can result in deleterious effects in overall system performance. Therefore, the present invention envisions the use of a nonlinear filter to control rapid upward excursions, or increases, in transmitter power. Furthermore, the present invention also utilizes closed loop power adjustment feedback from the cell-site to adjust mobile unit transmitter power.

Figure 2C illustrates the mobile unit transmitter power corresponding to Figure 2A without taking into consideration the cell-site closed loop power adjustment feedback. In Figure 2C the desired average transmit power, as represented by curve 34', corresponds to the mobile unit received signal strength of curve 30 of Figure 2A. Curve 38 illustrates the transmitter power utilizing the non-linear filter in power control of the present invention.

The rapid upward excursions in transmitter power, as indicated by the dashed lines of Figure 2C and correspond to the upward excursions in curve 36 of Figure 2B, are significantly reduced. In curve 38, the upward excursions are significantly reduced by setting the rate of increase in transmit power to a fixed value. The resulting variation in transmitter power relative to the desired transmit power is both limited in dynamic range and in rate of change. This limitation allows the closed loop power

2072989

17

adjustment feedback process to be easier to implement and to be more effective at a much lower control data rate. Transmit power, as indicated by curve 38, is permitted to decrease at a much greater rate than an increase.

5 As distance increases from the points marked D_1 - D_2 , transmitter power decreases rather quickly corresponding to a sudden improvement in the channel. Between the distance points marked D_2 - D_3 the channel degrades with a corresponding increase in transmitter power. The change in degradation is not so significant such that the non-linear filter
10 maximum rate limits the rate of increase in transmitter power.

As distance increases as from the distance points marked D_3 - D_4 , the channel degrades much more rapidly than the nonlinear filter will permit an increase in transmitter power. During this period, transmitter power increases at the maximum rate permitted by the non-linear filter. During
15 the distance change indicated by marks D_4 - D_5 , the channel begins improving. However, as the quality of the channel improves the transmitter power continues to increase at the maximum rate until transmitter power is sufficient to meet the desired level such as at mark D_5 .

20 It is desirable to eliminate the upward excursions in transmitter power which may cause unnecessary system interference. Should a better path to another cell-site occur, which would result in unnecessary interference in the system, quality communications in the system may be maintained by limiting the rate of increase in transmitter power.

25 Figure 2D is a graph illustrating the cell-site received signal power strength with respect to transmissions of the mobile unit as it travels from the cell-site. Curve 40 indicates the desired average received signal power at the cell-site for a signal transmitted from a mobile unit. It is desirable that the average received signal power be at a constant level, yet a
30 minimum necessary to assure a quality communication link with the mobile unit. Corrections are made at the mobile unit to correct for Rayleigh fading in the cell-site transmitted signal.

The mobile unit transmitted signal experiences Rayleigh fading before arriving at the cell-site receiver. The signal received at the cell-site
35 is therefore a signal of constant average received power level but still with

2072989

the Rayleigh fading of the inbound channel impressed thereupon. Curve 42 represents the Rayleigh fading that occurs on the inbound signal.

Additionally, there is the possibility that the mobile unit may come to rest at a place where the outbound link is not faded but yet the inbound link is severely faded. Such a condition would disrupt communications unless an additional mechanism is employed to compensate for the inbound channel Rayleigh fading. The closed loop power adjustment command process employed at the cell-site is such a mechanism for adjusting the mobile unit transmitter power, so as to compensate for the Rayleigh fading on the inbound channel. In Figure 2D, curve 44 illustrates the mobile unit transmitted signal power as received at the cell-site when compensating for average path loss and Rayleigh fading on both the inbound and outbound channels. As can be seen in Figure 2D curve 44 follows close to curve 40 except for instances of severe fading where the fading process is minimized by the closed loop control.

In Figure 3, antenna 52 is provided for receiving multiple mobile unit transmitted signals which are then provided to analog receiver 54 for amplification, frequency downconversion and IF processing of the received RF signal. The analog signals output from receiver 54 are provided to a plurality of receiver modules for, extraction of user directed information signals, generation of power adjustment commands, and modulation of user input information signals for transmission. One such module used in communications with a particular mobile unit, such as mobile unit N, is module 50. Thus the output of receiver 54 is provided to a plurality of these modules including module 50.

Module 50 comprises digital data receiver 56, user digital baseband circuit 58, received power measurement circuitry 60 and transmit modulator 62. Digital data receiver 56 receives the wideband spread spectrum signals for correlating and despreading the mobile unit N transmitted signal to a narrowband signal for transfer to an intended recipient communicating with mobile unit N. Digital data receiver 56 provides the narrowband digital signals to user digital baseband circuitry 58. Digital data receiver 56 also provides the narrowband signal to received power measurement circuitry 60.

Received power measurement circuitry 60 measures the power

2072989

level in the received signal from mobile unit N. Received power measurement circuitry 60 in response to the measured level of power generates a power adjustment command which is input to transmit modulator 62 for transmission to mobile unit N. As previously discussed, the data bits in the power adjustment command are used by mobile unit N in adjusting mobile unit transmitter power.

When the received power measurement is greater than the preset level provided by a cell-site processor (not shown), an appropriate power adjustment command is generated. Should the received power measurement be less than the preset level, the power adjustment command data bits are generated and indicate that an increase in mobile unit transmitter power is necessary. Similarly, if the received measurement is greater than the preset level, the power adjustment command is generated such that the mobile unit transmitter power is reduced. The power adjustment command is utilized to maintain a nominal received power level at the cell-site.

The signal output from digital data receiver 56 is provided to user digital baseband circuitry 58 where it is interfaced for coupling to the intended recipient via the system controller and switch. Similarly, baseband circuitry 58 receives user information signals intended for mobile unit N and provides them to transmit modulator 62.

Transmit modulator 62 spread spectrum modulates the user addressable information signals for transmission to mobile unit N. Transmit modulator 62 also receives the power adjustment command data bits from received power measurement circuitry 60. The power adjustment command data bits are also spread spectrum modulated by transmit modulator 62 for transmission to mobile unit N. Transmit modulator 62 provides the spread spectrum modulated signal to summer 64 where combined with spread spectrum signals from other module transmit modulators also located at the cell-site.

The combined spread spectrum signals are input to summer 66 where they are combined with a pilot signal provided by pilot signal generator 68. These combined signals are then provided to circuitry (not shown) for frequency upconversion from the IF frequency band to the RF frequency band and amplified. The RF signals are then provided to

2072989

20

antenna 52 for transmission. Although not illustrated, transmit power control circuitry may be disposed between summer 66 and antenna 52. This circuitry, under control of the cell-site processor, is responsive to power adjustment command signals transmitted by the mobile unit which are demodulated at the cell-site receiver and provided to the cell-site control processor for coupling to the circuitry.

In Figure 4, the mobile unit, such as mobile unit N, includes an antenna 70 for collecting cell site transmitted signals and radiating mobile unit generated CDMA signals. Mobile unit N receives the pilot signal, setup channel signals and the mobile unit N addressed signals using antenna 70, analog receiver 72 and digital data receiver 74. Receiver 72 amplifies and frequency downconverts the received RF CDMA signals to IF, and filters the IF signals. The IF signals are output to digital data receiver 74 for digital processing. Receiver 72 also includes circuitry for performing an analog measurement of the combined power of the received signals. This power measurement is used to generate a feedback signal that is provided to transmit power control circuitry 76 for controlling transmit power.

Digital data receiver 74 is used for despreading and correlating the received signals addressed to mobile unit N. Receiver 74 also separates the digital data from the power adjustment commands generated by the cell site. The power adjustment command data bits are sent to control processor 78. Processor 78 in response to the power adjustment command data bits generates a transmit power control command that is provided to transmit power control circuitry 80. Processor 78 also provides a level set command to transmit power control circuitry 76. Further details on the interaction of receiver 72, transmit power control 76 and 80, and processor are described in further detail with reference to Figure 5.

Receiver 74 also provides data such as digitized encoded speech to user digital baseband circuitry 82 for decoding and interface with the user. Baseband circuitry 82 includes interface hardware for coupling receiver 74 and transmit modulator 82 to the user handset (not shown).

Data to be transmitted is provided through baseband circuitry 82 where it is encoded and provided to transmit modulator 84. The data is spread spectrum modulated by transmit modulator 84 according to an

2072989

21

assigned spreading code. The spread spectrum signals are output from transmit modulator 84 to transmit power control circuitry 80. The signal power is adjusted in accordance with the transmit power control command provided by control processor 78. This power adjusted signal is provided from transmit power control circuitry 80 to transmit power control circuitry 76 where the signal is adjusted in accordance with the analog measurement control signal. Although illustrated as two separate units for controlling the transmit power, the power level could be adjusted by a single variable gain amplifier with two input control signals combined before being applied to the variable gain amplifier. However in the illustrated exemplary embodiment the two control functions are shown as separate elements.

In the operation of the power control circuitry illustrated in Figure 4, receiver 72 measures the combined power level of all signals received from all cell-sites. These power level measurement results are used in controlling the power level as set by transmit power control circuitry 76. Transmit power control circuitry 76 includes circuitry in which the rate of increase transmitter power is limited by a non-linear filter as previously discussed. The rate of increase is set to be no faster than the rate at which transmit power control circuitry 80 can turn the power down in response to a series of downward commands from the cell-site as processed by receiver 74 and processor 78.

Figure 5 illustrates in further detail the power control aspect of mobile unit N discussed with reference to Figure 4. In Figure 5, received RF signals from the antenna are provided to frequency downconverter 90 where the received RF signals are converted to an IF frequency. The IF frequency signals are coupled to bandpass filter 92 where out of band frequency components are removed from the signals.

The filtered signals are output from filter 92 to variable gain IF amplifier 94 where the signals are amplified. The amplified signals are output from amplifier 94 to an analog to digital (A/D) converter (not shown) for digital signal processing operations on the signals. The output of amplifier 94 is also coupled to automatic gain control (AGC) detector circuit 96.

AGC detector circuit 96 generates a gain control signal which is

2072989

22

coupled to a gain control input of amplifier 94. This gain control signal is used to control the gain of the amplifier 94 so as to maintain a constant average power level as output from amplifier 94 to the A/D converter.

5 AGC detector circuit 96 also provides an output to one input of comparator 98. The other input of comparator 98 is provided with a level set signal from the mobile unit processor (not shown). This level set signal is indicative of a desired transmitter reference power level. These input signals are compared by comparator 98 with the comparison signal provided to a non-linear filter circuit 100. This comparison signal
10 corresponds to a deviation in the received power measurement from a desired mobile unit transmitter power level.

Filter 100 may be configured as a simple resistor-diode-capacitor circuit. For example, the input to the circuit is a common node shared by two resistors. The other end of each resistor is coupled to a respective
15 diode. The diodes are reversed in their connection to the resistors and the other end of each diode coupled together at a common node as an output of the filter. A capacitor is coupled between the diode common node and ground. The filter circuit is designed to limit the rate of power increase to less than 1 dB per millisecond. The rate of power decrease is typically set
20 to be about ten times faster than the rate of power increase, i.e. 10 dB per millisecond. The output of filter 100 is provided as a power level control signal input to the gain control input of variable gain IF amplifier 102.

AGC detector circuit 96, comparator 98 and filter 100 estimate received mobile unit signal power and the power correction necessary for
25 the mobile unit transmitter. This correction is used to maintain a desired transmitter power level in conditions of fading on the outbound channel that are common to the inbound channel.

Transmit modulator circuit 84 of Figure 4, provides a low power, IF frequency spread spectrum signal to an input of variable gain IF
30 amplifier 104. Amplifier 104 is gain controlled by a power level control signal from processor 78 (Figure 4). This power level control signal is derived from the closed loop power adjustment command signal transmitted by the cell-site and processed by the mobile unit as discussed with reference to Figure 4.

35 The power adjustment command signal consists of a sequence of

2072989

23

power-up and power-down commands that are accumulated in the mobile unit processor. The mobile unit control processor starts with the gain control level set to a nominal value. Each power-up command increases the value of a gain control command corresponding to a resultant
5 approximate 1 dB increase in amplifier gain. Each power-down command decreases the value of the gain control command, corresponding to a resultant approximate 1 dB decrease in amplifier gain. The gain control command is converted to analog form by a digital to analog (D/A) converter (not shown) before applied to amplifier 104 as the power level
10 control signal.

The mobile unit reference power level may be stored in the memory of the control processor. In the alternative, the mobile unit reference power level may be contained within a signal sent to the mobile unit. This signal command data is separated by the digital data receiver
15 and interpreted by the control processor in setting the level. This signal as provided from the control processor is converted by a digital to analog (D/A) converter (not shown) before input to comparator 98.

The output of amplifier 104 is provided as an input to amplifier 102. Amplifier 102 as previously mentioned is also a variable gain IF amplifier
20 with the gain determined according to the power level control signal output from filter 100. The signal for transmission is thus amplified in accordance with the gain set by the power level control signal. The amplified signal output from amplifier 102 and is further amplified and frequency translated to the RF frequency for transmission. The RF signal
25 is then fed to the antenna for transmission.

Figure 6 illustrates in further detail the power control scheme of the cell-site as illustrated in Figure 3. In Figure 6, a mobile unit transmitted signal is received at the cell-site. The received signal is processed by the cell-site analog receiver and cell-site corresponding to mobile unit N.

30 In the digital data receiver, receiver 56 of Figure 3, the received analog signal is converted from analog to digital form by A/D converter 110. The digital signal output from A/D converter is provided to pseudorandom noise (PN) correlator 112 where the signal undergoes a correlation process with a PN signal provided from PN generator 114.
35 The output of PN correlator 112 is provided to a fast Hadamard transform

2072989

24

digital filter 114 where the signal is filtered. The output of filter 114 is provided to a user data decoder circuit 116 which provides user data to the user digital baseband circuitry. Decoder 116 provides the largest transform filter symbols to power averager circuit 118. Power averager circuit 118 averages the largest transform outputs over a one millisecond interval using well known digital techniques.

A signal indicative of each average power level is output from power averager 118 to comparator 120. Comparator 120 also receives a power level set signal indicative of the desired received power level. This desired received power level is set by the control processor for the cell-site. Comparator 120 compares the two input signals and provides an output signal indicative of the deviation of the average power level from the desired power level. This signal is provided output to power up/down command generator 122. Generator 122 in response to the comparison generates either a power-up or a power-down command. Power command generator 122 provides the power control commands to the cell-site transmit modulator for transmission and control of the transmitter power of mobile unit N.

If the received power at the cell-site is higher than that desired of mobile unit N, then a power-down command is generated and transmitted to mobile unit N. However, if the received power level at the cell-site is too low, then a power-up command is generated and transmitted. The up/down commands are transmitted at a high rate, nominally 1,000 commands per second in the exemplary embodiment. At one bit per command, the overhead of the power command is insignificant compared to the bit rate of a high quality digital voice signal.

The power adjustment command feedback compensates for changes in the inbound channel that are independent of the outbound channel. These independent inbound channel changes are not measured in the outbound channel signal. Therefore the path loss estimate based upon then outbound channel and the corresponding transmitter power adjustment do not reflect the changes in the inbound channel. Thus, the power adjustment command feedback is used to compensate for adjustments in the mobile unit transmitter power based on the inbound channel path losses that do not exist in the outbound channel.

In using a closed loop control process it is highly desirable for the command to arrive at the mobile unit before conditions change significantly. The present invention provides a novel and unique power control circuitry at the cell-site for minimizing delay and latency of measurement and transmission. The power control circuitry at the mobile unit, analog control and digital command response, provides a vastly improved power control process in the cellular mobile telephone system.

The previous description of the preferred embodiments are provided to enable any person skilled in the art to make or use the present invention. Various modifications to these embodiments will be readily apparent to those skilled in the art, and the generic principals defined herein may be applied to other embodiments without the use of the inventive faculty. Thus, the present invention is not intended to be limited to the embodiments shown herein, but is to be accorded the widest scope consistent with the principals and novel features disclosed herein.

WE CLAIM:

CLAIMS

2

1. In a cellular mobile telephone system in which system users
4 communicate information signals between one another via at least one cell-site using
code division multiple access (CDMA) spread spectrum communication signals, a
6 power control system for controlling transmission signal power for each mobile
telephone in said cellular mobile telephone system, wherein each mobile telephone
8 has an antenna, transmitter and receiver and each cell-site has an antenna, at least
one transmitter and at least one receiver, said power control system comprising:

10 at least one first power measurement means, each coupled to a respective
mobile telephone receiver, for measuring signal power in CDMA communication
12 signals received by said respective mobile telephone receiver;

at least one first power adjustment means, each coupled to a respective mobile
14 telephone transmitter and corresponding first power measurement means, said first
power adjustment means responsive to decreases and increases in power
16 measurements of said corresponding first power measurement means with respect to
a first predetermined power level, for respectively increasing and decreasing
18 transmission signal power of said corresponding mobile telephone transmitter;

at least one second power measurement means, each coupled to a respective
20 cell-site receiver, for measuring signal power in each CDMA communication signal
directed to said respective cell-site receiver from a corresponding mobile telephone
22 transmitter in communication therewith;

at least one power adjustment command generator means, each coupled to a
24 respective cell-site transmitter and corresponding second power measurement
means, for generating power adjustment commands corresponding to deviations in
26 power measurements of said corresponding second power measurement means from
a second predetermined power level, said respective cell-site transmitter transmitting
28 said power adjustment commands; and

at least one second power adjustment means, each coupled to a

2072989

27

34 respective mobile telephone receiver and corresponding transmitter, said
second power adjustment means responsive to said power adjustment
36 commands directed to said respective mobile telephone receiver, for
adjusting transmission signal power of said corresponding mobile
38 telephone transmitter.

2. The power control system of Claim 1 wherein said first power
2 adjustment means provided increase in transmission signal power is at a
rate less than said first power adjustment means provided decrease in
4 transmission signal power.

3. The power control system of Claim 1 wherein said first power
2 measurement means power measurements correspond to a sum of all
contemporaneously received CDMA communication signals within a
4 predetermined frequency band, and said first power measurement means
is further for generating and providing a corresponding first power
6 measurement signal to said corresponding first power adjustment means.

4. The power control system of Claim 3 wherein said first power
2 adjustment means comprises:

comparator means for receiving said first power measurement
4 signal and a first power level set signal, said first power level set signal
corresponding to a desired mobile telephone transmitter power level, for
6 comparing said first power measurement signal with said first power level
set signal, and for providing a corresponding comparator output signal;
8 and

variable gain amplification means operatively coupled to said
10 mobile telephone transmitter for receiving said comparator output signal
and responsive thereto for varying transmission signal power of said
12 corresponding mobile telephone transmitter.

5. The power control system of Claim 4 further comprising
2 filter means disposed between said comparator means and said variable
gain amplification means for receiving said comparator output signal, for
4 unequally limiting a rate of change in increases and decreases in said

74769-4

28

received comparator output signal and for providing a corresponding limited comparator output signal to said variable gain amplification means.

6. An apparatus for controlling transmission signal
5 power in a cellular mobile telephone in communications with at least one cell-site station using code division multiple access (CDMA) spread spectrum communication signals, said cellular mobile telephone having an antenna coupled to a transmitter and a receiver, said transmitter for generating and transmitting a
10 CDMA carrier signal according to an assigned spreading function modulated by a mobile user input information signal, said receiver for receiving CDMA communication signals and spectrum processing said received CDMA communication signals according to an assigned spreading function so as to recover a mobile
15 user output information signal intended for a user of said cellular mobile telephone, said cell-site station communicating power adjustment commands in CDMA communication signals intended for said cellular mobile telephone with said receiver providing an output of said power adjustment commands, said
20 apparatus comprising:

measurement means, operatively coupled to said receiver, for measuring combined signal power in contemporaneously received CDMA communication signals and providing a measurement signal indicative of measured signal
25 power;

adjustment means, operatively coupled to said transmitter, for receiving said measurement signal, varying transmitter signal power in opposite correspondence to variations in measured signal power about a predetermined power
30 level; and

74769-4

29

additional adjustment means, operatively coupled to said receiver and transmitter, for receiving said power adjustment commands, and varying transmitter signal power in correspondence thereto.

5 7. The apparatus of Claim 6 wherein said adjustment means is responsive to said measurement signal for, increasing transmitter signal power in response to decreases in measured signal power with respect to said predetermined power level, and decreasing transmitter signal power in response to
10 increases in measured signal power with respect to said predetermined power level.

8. The apparatus of Claim 7 wherein said adjustment means provides an increase in transmitter signal power at a rate less than said adjustment means provides a decrease in
15 transmitter signal power.

9. The apparatus of Claim 6 wherein said cell-site station measures signal power of said cellular mobile telephone transmitted CDMA communication signals and generates for transmission said power adjustment commands indicative of one
20 of an increase and a decrease in said cellular mobile telephone signal power so as to maintain a predetermined power level for cell-site station received CDMA communication signals from said cellular mobile telephone.

10. The apparatus of Claim 6 wherein said adjustment
25 means comprises:

comparator means for receiving said measurement signal and a first power level set signal, said first power level set signal corresponding to a desired cellular mobile telephone transmitter power level, for comparing said

74769-4

29a

measurement signal with said first power level set signal, and
for providing a corresponding comparator output signal;

filter means for, receiving said comparator output
signal, limiting a rate of change in variations in said
5 comparator output signal, and providing an output of a
corresponding limited comparator output signal; and

variable gain amplification means, operatively
coupled to said transmitter, for receiving said limited
comparator output signal and responsive thereto for varying
10 signal power of said transmitter.

11. The apparatus of Claim 10 wherein said additional
adjustment means comprises:

processor means for, receiving said power adjustment
commands, accumulating said power adjustment commands with a
15 predetermined gain control level setting, and providing a
corresponding power

adjustment signal; and

2 additional variable gain amplification means, operatively coupled
to said transmitter, for receiving said power adjustment signal and
4 responsive thereto for varying signal power of said transmitter.

12. A transceiver having a receiver for receiving and
2 demodulating an outbound information containing spread spectrum
signal as transmitted by a base station to an intended user, and a
4 transmitter for transmitting an inbound information containing spread
spectrum signal to said base station for transfer to another intended user,
6 said transceiver having a power control system for controlling transmitter
signal power of said inbound spread spectrum signal at a substantially
8 constant level as received at said base station wherein said base station
measures signal power of said inbound spread spectrum signal, generates
10 power adjustment commands according to variations in said measured
signal power of said inbound spread spectrum signal with respect to a
12 predetermined received inbound spread spectrum signal power level and
transmits said power level adjustment commands in said outbound
14 spread spectrum signal, said power control system comprising:

control processor means, coupled to said receiver, for receiving from
16 said receiver said power adjustment commands transmitted in said
outbound spread spectrum signal, accumulating values corresponding to
18 said power adjustment commands with respect to a predetermined closed
loop power level value, and generating a corresponding closed loop power
20 level control signal, said control processor means further for generating an
open loop power level signal indicative of a predetermined open loop
22 power level value;

first amplifier means, operatively coupled to said transmitter, for
24 receiving said closed loop power level control signal from said control
processor means, and amplifying said inbound spread spectrum signal at a
26 first gain determined by said closed loop power level control signal for
transmission by said transmitter;

28 automatic gain control means, coupled to said receiver, for
measuring signal power of outbound spread spectrum signals received by
30 said receiver, and providing a corresponding power measurement signal;

comparator means for receiving and comparing said power
2 measurement signal and said open loop power level signal, and providing
a corresponding open loop power level control signal; and

4 second amplifier means, operatively coupled to said transmitter, for
receiving said open loop power level control signal, and amplifying said
6 inbound spread spectrum signal at a second gain determined by said open
loop power level control signal.

13. The transceiver of Claim 12 wherein said receiver has an
2 analog receiver portion and a digital receiver portion, said automatic gain
control means coupled to said analog receiver portion for measuring
4 wideband signal power of all received outbound spread spectrum signals.

14. The transceiver of Claim 12 further comprising filter means
2 for non-linearly limiting a rate of change in said open loop power level
control signal so as to provide a rate of change in increases of said open
4 loop power level control signal that is greater than a rate of change in
decreases in said open loop power level control signal.

15. The transceiver of Claim 12 wherein an increase in measured
2 outbound spread spectrum signal power corresponds to an increase in said
open loop power level control signal with said second amplifier means
4 responsive thereto for decreasing said second gain, and a decrease in
measured outbound spread spectrum signal power corresponds to a
6 decrease in said open loop power level control signal with said second
amplifier means responsive thereto for increasing said second gain.

16. The transceiver of Claim 13 wherein said digital receiver
2 portion extracts said power adjustment commands from said outbound
spread spectrum signal and said control processor means is coupled to said
4 digital receiver portion for receiving said power adjustment commands so
as to generate said closed loop power level control signal, wherein each
6 power adjustment command affects a change in said closed loop power
level control signal with said first amplifier means responsive to each
8 change in said closed loop power level control signal so as to provide a

31/1

corresponding change in said first gain.

- 2 17. The transceiver of Claim 16 wherein each change in said first gain corresponds to a predetermined dB change in gain of said transmitter.

2072989

32

18. A system for controlling transmission power of a first
2 transceiver capable of transmitting information signals of a first user,
4 using spread spectrum communication signals, to a second transceiver for
6 transfer to a second user, and capable of extracting information signals of a
8 second user transmitted to said first transceiver by said second transceiver,
10 also using spread spectrum communication signals, said system
12 comprising:

8 open loop power control means operatively coupled to said first
10 transceiver for controlling signal power of said first transceiver
12 transmitted spread spectrum communication signals in opposite
14 correspondence to variations in signal power of first transceiver received
16 spread spectrum communication signals; and

14 closed loop power control means operatively coupled to said first
16 and second transceiver for further controlling signal power of said first
transceiver transmitted spread spectrum communication signals in
opposite correspondence to variations in signal power of second
transceiver received spread spectrum communication signals.

19. The system of Claim 18 wherein said open loop power
2 control means provides increases in signal power at a rate less than
decreases in signal power.

20. The system of Claim 18 wherein said open loop power
2 control means provides increases in signal power at a rate less than said
closed loop power control means provides decreases in signal power.

21. The system of Claim 18 wherein said open loop power
2 control means compensates for variations in channel conditions affecting
4 signal power in a second transceiver to first transceiver communication
channel.

22. The system of Claim 18 wherein said closed loop power
2 control means compensates for variations in channel conditions affecting
signal power in a first transceiver to second transceiver communication

4 channel.

23. The system of Claim 18 wherein said open loop power
2 control means comprises:

4 means for measuring signal power of first transceiver received
spread spectrum communication signals; and

6 means for adjusting signal power, of said first transceiver
transmitted spread spectrum communication signals, in opposite
8 correspondence to deviations in said first transceiver measured signal
power with respect to a predetermined transmission power level.

24. The system of Claim 18 wherein said closed loop power
2 control means comprises:

4 means for measuring signal power of second transceiver received
spread spectrum communication signals transmitted by said first
transceiver;

6 means for generating power adjustment commands in opposite
correspondence to deviations in said second transceiver measured signal
8 power with respect to a desired reception power level;

10 means for inserting said power adjustment commands in said
spread spectrum communication signals as transmitted by said second
transceiver to said first transceiver ; and

12 means for further adjusting signal power of said first transceiver
transmitted spread spectrum communication signals in correspondence
14 with said power adjustment commands as received by said first
transceiver.

25. The system of Claim 23 wherein said closed loop power
2 control means comprises:

4 means for measuring signal power of second transceiver received
spread spectrum communication signals transmitted by said first
transceiver;

6 means for generating power adjustment commands in opposite
correspondence to deviations in said second transceiver measured signal
8 power with respect to a desired reception power level;

10 means for inserting said power adjustment commands in said
spread spectrum communication signals as transmitted by said second
transceiver to said first transceiver ; and

12 means for further adjusting signal power of said first transceiver
transmitted spread spectrum communication signals in correspondence
14 with said power adjustment commands as received by said first
transceiver.

26. The system of Claim 25 wherein said means for measuring
2 signal power of first transceiver received spread spectrum communication
signals measures wideband signal power, and said means for measuring
4 signal power of second transceiver received spread spectrum
communication signals transmitted by said first transceiver digitally
6 measures narrowband signal power.

27. The system of Claim 18 further comprising additional closed
2 loop power control means operatively coupled to said first and second
transceiver for controlling signal power of said second transceiver
4 transmitted spread spectrum communication signals in opposite
correspondence to variations of a measured ratio, of signal power of first
6 transceiver received spread spectrum communication signals to a signal
power of interfering signals, with respect to a desired ratio.

28. The system of Claim 27 wherein said additional closed loop
2 power control means comprises:

means for measuring signal power of all first transceiver received
4 spread spectrum communication signals including other transceiver
transmitted spread spectrum communication signals and multipath
6 signals of said spread spectrum communication signals transmitted by said
second transceiver, measuring signal power of first transceiver received
8 spread spectrum communication signals as transmitted by said second
transceiver, comparing said measured signal power of first transceiver
10 received spread spectrum communication signals as transmitted by said
second transceiver with said measured signal power of all first transceiver
12 received spread spectrum communication signals so as to provide a

14 signal-to-interference ratio value, generating power adjustment requests
16 in opposite correspondence to deviations in said signal-to-interference
18 ratio value with respect to a desired predetermined signal-to-interference
ratio value, and inserting said power adjustment requests in said spread
spectrum communication signals as transmitted by said first transceiver to
said second transceiver; and

means for adjusting signal power of said second transceiver
20 transmitted spread spectrum communication signals in correspondence
with said power adjustment requests as received by said second
22 transceiver.

29. A method for controlling transmission power of a first
2 transceiver capable of communicating information signals of a first user,
using spread spectrum communication signals, to a second transceiver for
4 transfer to a second user and capable of extracting information signals of a
second user communicated to said first transceiver by said second
6 transceiver using said spread spectrum communication signals, said
method comprising the steps of:

8 controlling signal power of said first transceiver transmitted spread
spectrum communication signals in opposite correspondence to
10 variations in signal power of first transceiver received spread spectrum
communication signals ; and

12 controlling signal power of said first transceiver transmitted spread
spectrum communication signals in opposite correspondence to
14 variations in signal power of second transceiver received spread spectrum
communication signals.

30. The method of Claim 29 wherein said step of controlling
2 signal power of said first transceiver transmitted spread spectrum
communication signals in opposite correspondence to variations in signal
4 power of first transceiver received spread spectrum communication
signals comprises the steps of :

6 measuring signal power of first transceiver received spread
spectrum communication signals; and

8 adjusting signal power, of said first transceiver transmitted spread

2072989

36

10 spectrum communication signals, in opposite correspondence to
deviations in said first transceiver measured signal power with respect to a
predetermined transmission power level.

31. The system of Claim 29 wherein said step of controlling
2 signal power of said first transceiver transmitted spread spectrum
communication signals in opposite correspondence to variations in signal
4 power of second transceiver received spread spectrum communication
signals comprises the steps of:
6 measuring signal power of second transceiver received spread
spectrum communication signals transmitted by said first transceiver;
8 generating power adjustment commands in opposite
correspondence to deviations in said second transceiver measured signal
10 power with respect to a desired reception power level;
inserting said power adjustment commands in said spread
12 spectrum communication signals as transmitted by said second transceiver
to said first transceiver ; and
14 adjusting signal power of said first transceiver transmitted spread
spectrum communication signals in correspondence with said power
16 adjustment commands as received by said first transceiver.

32. The system of Claim 30 wherein said step of controlling
2 signal power of said first transceiver transmitted spread spectrum
communication signals in opposite correspondence to variations in signal
4 power of second transceiver received spread spectrum communication
signals comprises the steps of:
6 measuring signal power of second transceiver received spread
spectrum communication signals transmitted by said first transceiver;
8 generating power adjustment commands in opposite
correspondence to deviations in said second transceiver measured signal
10 power with respect to a desired reception power level;
inserting said power adjustment commands in said spread
12 spectrum communication signals as transmitted by said second transceiver
to said first transceiver; and
14 adjusting signal power of said first transceiver transmitted spread

2072989

37

16 spectrum communication signals in correspondence with said power
adjustment commands as received by said first transceiver.

2 33. The method of Claim 29 further comprising the step of
controlling signal power of said second transceiver transmitted spread
4 spectrum communication signals in opposite correspondence to
variations of a measured ratio, of signal power of first transceiver received
6 spread spectrum communication signals to a signal power of interfering
signals, with respect to a desired ratio.

2 34. The system of Claim 33 wherein said step of controlling
signal power of said second transceiver transmitted spread spectrum
communication signals comprises the steps of:

4 measuring signal power of all first transceiver received spread
spectrum communication signals including other transceiver transmitted
6 spread spectrum communication signals and multipath signals of said
spread spectrum communication signals transmitted by said second
8 transceiver;

10 measuring signal power of first transceiver received spread
spectrum communication signals as transmitted by said second
transceiver;

12 comparing said measured signal power of first transceiver received
spread spectrum communication signals as transmitted by said second
14 transceiver with said measured signal power of all first transceiver
received spread spectrum communication signals so as to provide a signal-
16 to-interference ratio value;

18 generating power adjustment requests in opposite correspondence
to deviations in said signal-to-interference ratio value with respect to a
desired signal-to-interference ratio value;

20 inserting said power adjustment requests in said spread spectrum
communication signals as transmitted by said first transceiver to said
22 second transceiver; and

24 adjusting signal power of said second transceiver transmitted spread
spectrum communication signals in correspondence with said power
adjustment requests as received by said second transceiver.

35. In a cellular mobile telephone system in which system users communicate information signals between one another via at least on cell-site using code division multiple access (CDMA) spread spectrum communication signals, a method for controlling transmission signal power for each mobile telephone in said cellular mobile telephone system, wherein each mobile telephone has an antenna, transmitter and receiver, and each cell-site has an antenna, at least one transmitter and at least one receiver, said method comprising the steps of:

measuring signal power in CDMA communication signals received by each respective mobile telephone receiver;

varying transmission signal power of each corresponding mobile telephone transmitter in inverse proportion to variations in corresponding mobile telephone power measurements with respect to a first predetermined power level;

measuring signal power in each CDMA communication signal received at each respective cell-site receiver as transmitted from a corresponding mobile telephone transmitter in communication therewith;

generating power adjustment commands corresponding to deviations in corresponding cell-site power measurements from a second predetermined power level;

transmitting said power adjustment commands along with said information signals from each respective cell-site to a corresponding mobile telephone in communication therewith;

receiving at each respective mobile telephone receiver said power adjustment commands corresponding thereto; and

adjusting transmission signal power of each corresponding mobile telephone transmitter in correspondence to said power adjustment commands directed to said respective mobile telephone receiver.

36. The method of Claim 35 wherein said step of varying transmission signal power of each corresponding mobile telephone transmitter in inverse proportion to variations in corresponding mobile telephone power measurements with respect to a first predetermined power level further comprises the step of:

limiting a rate of increase in transmission signal power of each corresponding mobile telephone transmitter less than a rate of decrease in transmission signal power of each corresponding mobile telephone transmitter.

5 37. The method of Claim 35 wherein said step of varying transmission signal power of each corresponding mobile telephone transmitter in inverse proportion to variations in corresponding mobile telephone power measurements with respect to a first predetermined power level comprises the steps of:

10 providing an increase in transmission signal power of each corresponding mobile telephone transmitter in response to a decrease in a corresponding mobile telephone power measurement with respect to said first predetermined power level; and

15 providing a decrease in transmission signal power of each corresponding mobile telephone transmitter in response to an increase in a corresponding mobile telephone power measurement with respect to said first predetermined power level.

38. The method of Claim 35 wherein said step of generating power adjustment commands corresponding to deviations in corresponding cell-site power measurements from a second predetermined power level comprises the steps of:

20 generating a power-up command in response to a decrease in a corresponding cell-site power measurement from said second predetermined power level; and

 generating a power-down command in response to an increase in a corresponding cell-site power measurement from said second predetermined power level.

25

39. The method of Claim 38 wherein said step of adjusting transmission signal power of each corresponding mobile telephone transmitter in correspondence to said power adjustment commands directed to said respective mobile telephone receiver comprises the steps

74769-4

40

of:

increasing mobile telephone transmitter signal in response to each power-up command; and

5 decreasing mobile telephone transmitter signal in response to each power-down command.

40. The method of Claim 37 wherein said step of generating power adjustment commands corresponding to deviations in corresponding cell-site power measurements from a second predetermined power level comprises the steps of:

10 generating a power-up command in response to a decrease in a corresponding cell-site power measurement from said second predetermined power level; and

generating a power-down command in response to an increase in a corresponding cell-site power measurement from
15 said second predetermined power level.

41. The method of Claim 40 wherein said step of adjusting transmission signal power of each corresponding mobile telephone transmitter in correspondence to said power adjustment commands directed to said respective mobile
20 telephone receiver comprises the steps of:

increasing mobile telephone transmitter signal power in response to each power-up command; and

decreasing mobile telephone transmitter signal power in response to each power-down command.

25 42. The method of Claim 35 wherein in said step of measuring signal power in CDMA communication signals received by each respective mobile telephone receiver, measured signal

74769-4

41

power corresponds to a sum of all contemporaneously received CDMA communication signals within a predetermined frequency band.

43. The method of Claim 35 further comprising the step of
5 generating a first power measurement signal corresponding to said measured signal power in CDMA communication signals received by each respective mobile telephone receiver.

44. The method of Claim 43 wherein said step of varying
10 transmission signal power of each corresponding mobile telephone transmitter in inverse proportion to variations in corresponding mobile telephone power measurements with respect to a first predetermined power level comprises the steps of:

15 comparing said first power measurement signal with a first power level set signal, said first power level set signal corresponding to a desired mobile telephone transmitter power level;

providing a comparator output signal corresponding to a difference between said first power measurement signal and said first power level set signal; and

20 varying mobile telephone transmitter gain according to said comparator output signal.

45. A method for controlling transmission signal power in a cellular mobile telephone in communications with at least one cell-site station using code division multiple access (CDMA)
25 spread spectrum communication signals, said cellular mobile telephone having an antenna coupled to a transmitter and a receiver, said transmitter for generating and transmitting a CDMA carrier signal according to an assigned spreading function

74769-4

41a

modulated by a mobile user input information signal, said receiver for receiving CDMA communication signals and spectrum processing said received CDMA communication signals according to an assigned spreading function so as to recover a mobile
5 user output information signal intended for a user of said cellular mobile telephone, said cell-site station communicating power control commands in CDMA communication signals intended for said cellular mobile telephone with said receiver processing said received power control commands and providing
10 an output of said power control commands, said method comprising the steps of:

measuring combined signal power in contemporaneously received CDMA communication signals and providing a measurement signal indicative of said combined signal power;

15 varying transmitter signal power in inverse proportion to variations in measured signal power about a predetermined power level; and

varying transmitter signal power in correspondence to received power adjustment commands.

5 46. The method of Claim 45 wherein said step of varying transmitter signal power in inverse proportion to variations in measured signal power about a predetermined power level comprises the steps of:

increasing transmitter signal power in response to decreases in measured signal power with respect to said predetermined power level; and

10 decreasing transmitter signal power in response to increases in measured signal power with respect to said predetermined power level.

47. The method of Claim 46 wherein increases in transmitter signal power are at a rate less than decreases in transmitter signal power.

15 48. The method of Claim 45 wherein said cell-site station measures signal power of said cellular mobile telephone transmitted CDMA communication signals and generates for transmission said power adjustment commands indicative of one of an increase and a decrease in said cellular mobile telephone signal power so as to maintain a predetermined power level for cell-site station received CDMA
20 communication signals from said cellular mobile telephone.

25 49. The method of Claim 45 wherein said step of measuring combined signal power in contemporaneously received CDMA communication signals further comprises the step of generating a measurement signal indicative of measured signal power, and wherein said step of varying transmitter signal power in inverse proportion to variations in measured signal power about a predetermined power level comprises the steps of:

generating a first power level set signal corresponding to a desired

74769-4

43

cellular mobile telephone transmitter power level;

comparing said measurement signal with said first power level set signal;

5 providing a comparator output signal corresponding to a difference between said desired cellular mobile telephone transmitter power level and said measured signal power;

limiting a rate of change in variations in said comparator output signal;

10 providing a corresponding limited comparator output signal; and

varying signal power of said transmitter in response to said limited comparator output signal.

50. The method of Claim 49 wherein said step of varying transmitter signal power in correspondence to received power 15 adjustment commands comprises the steps of:

accumulating said processed power adjustment commands with a predetermined gain control level setting;

20 providing a power adjustment signal corresponding to said accumulation of said processed power adjustment commands with said predetermined gain control level setting; and

varying signal power of said transmitter in response to said power adjustment signal.

SMART & BIGGAR

OTTAWA, CANADA

PATENT AGENTS

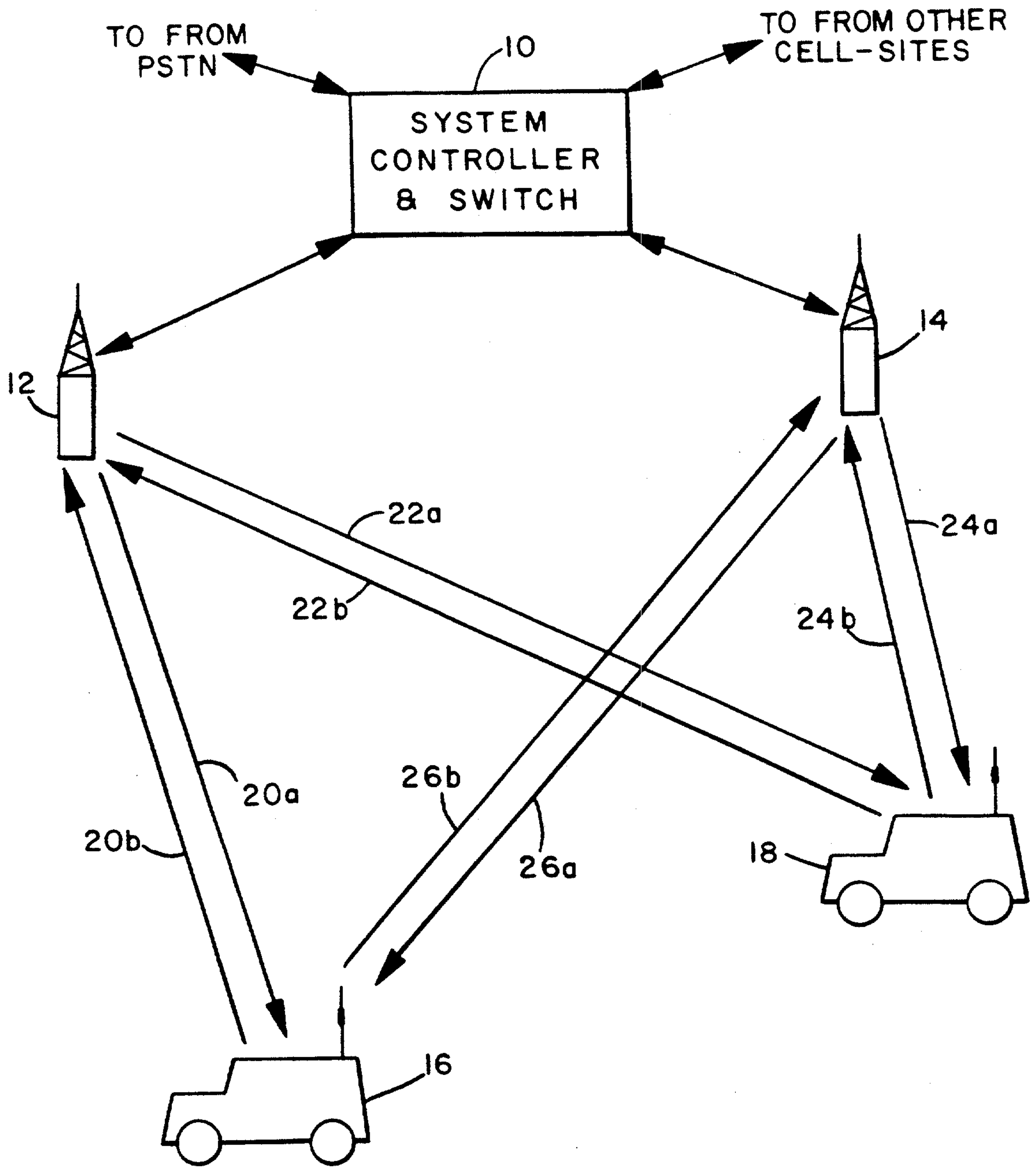

FIG. 1

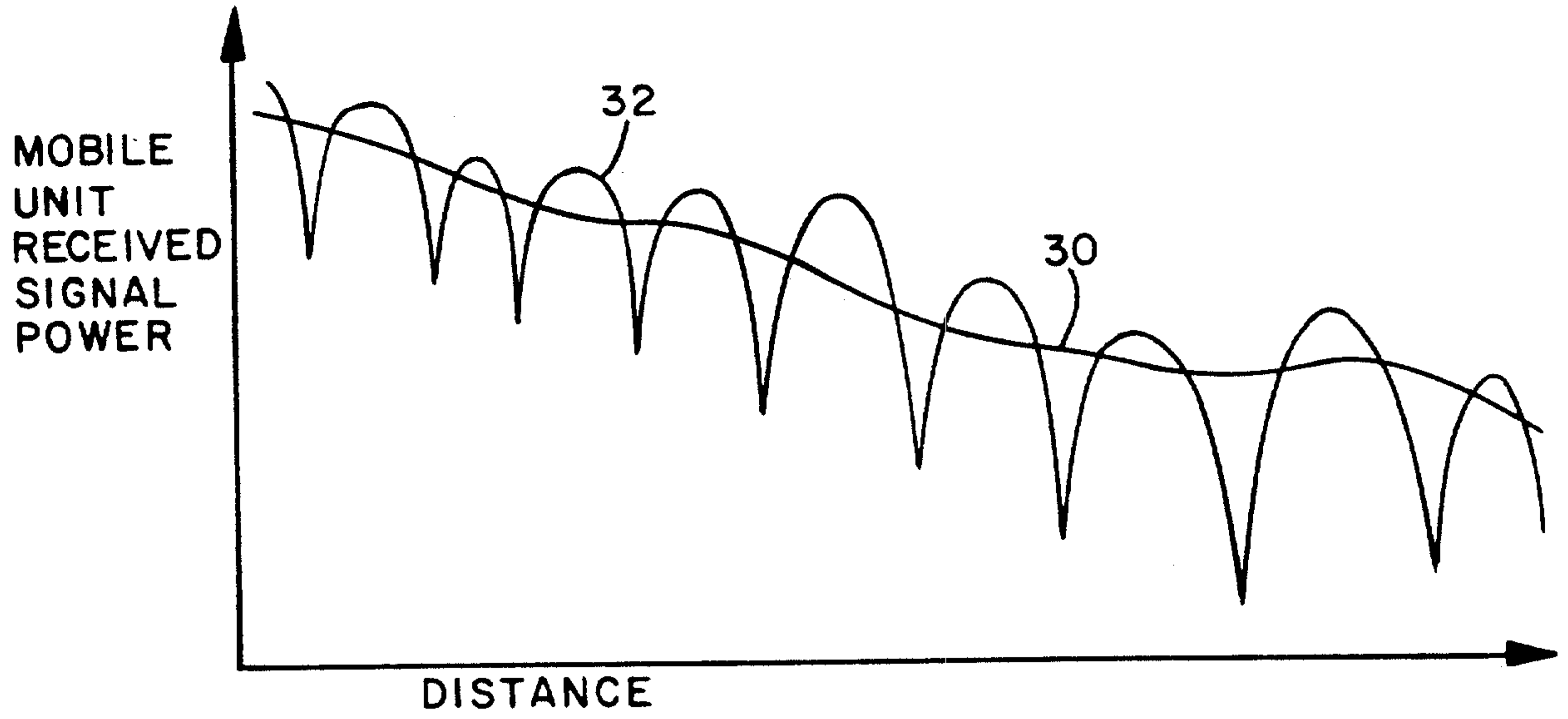

FIG. 2A

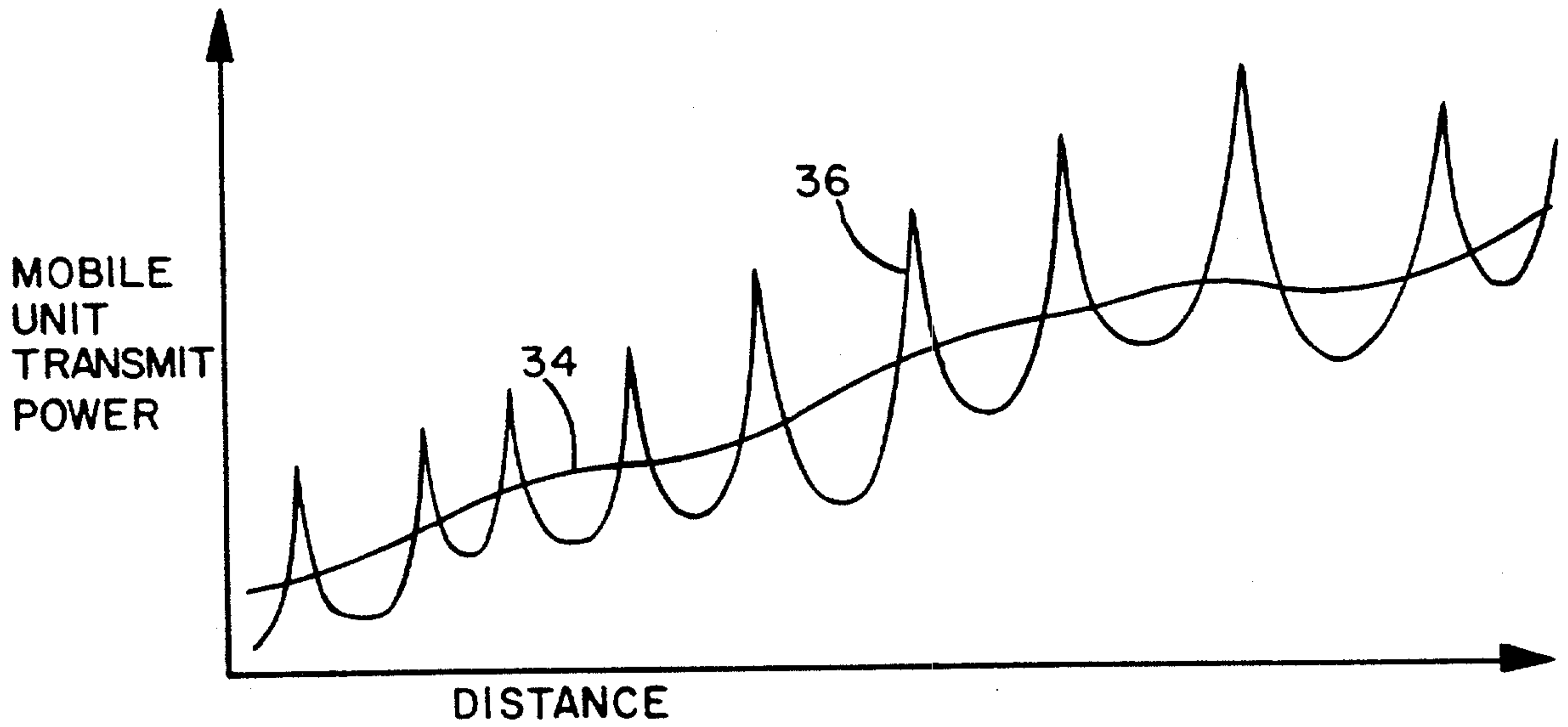

FIG. 2B

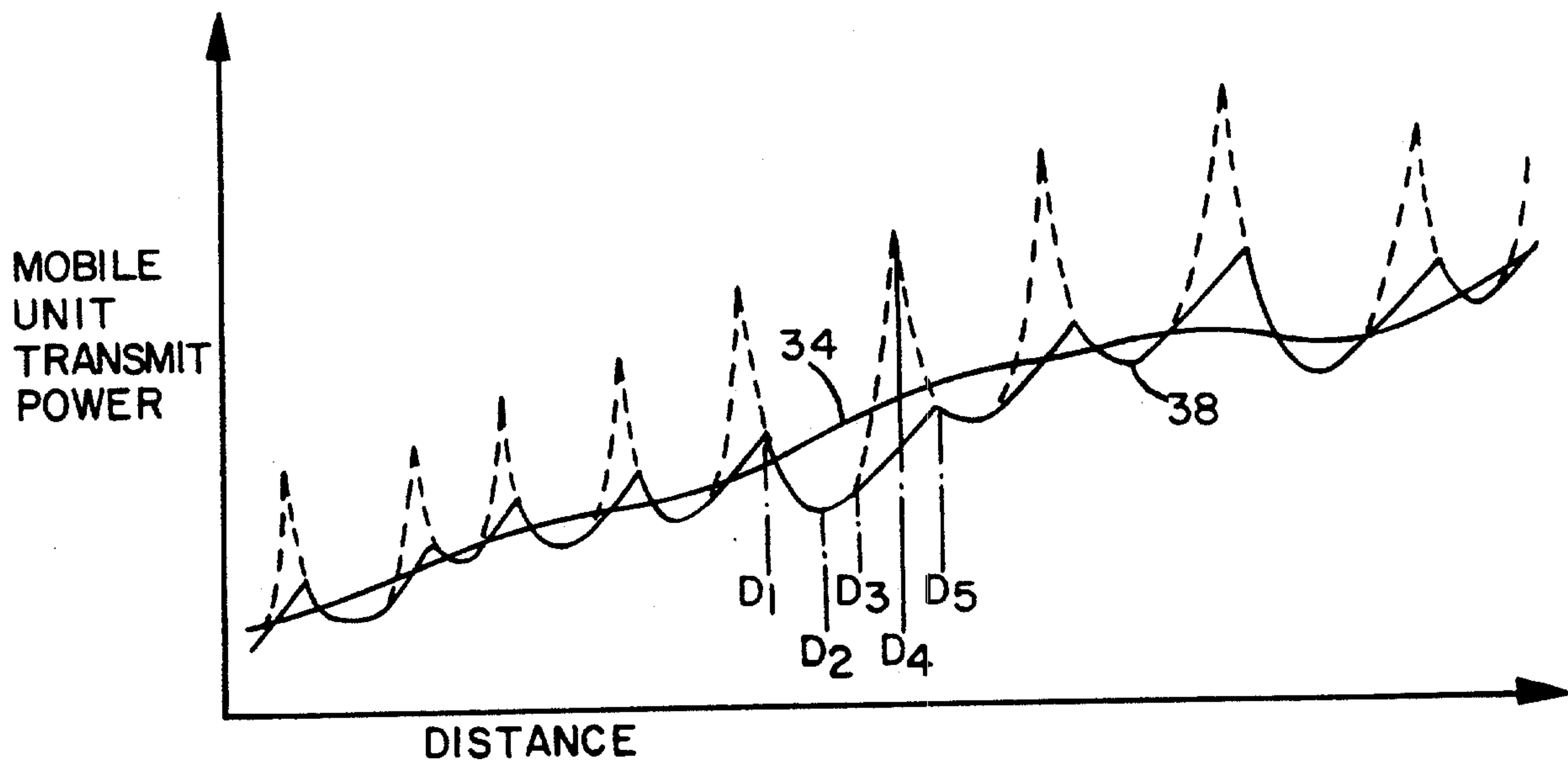

FIG. 2C

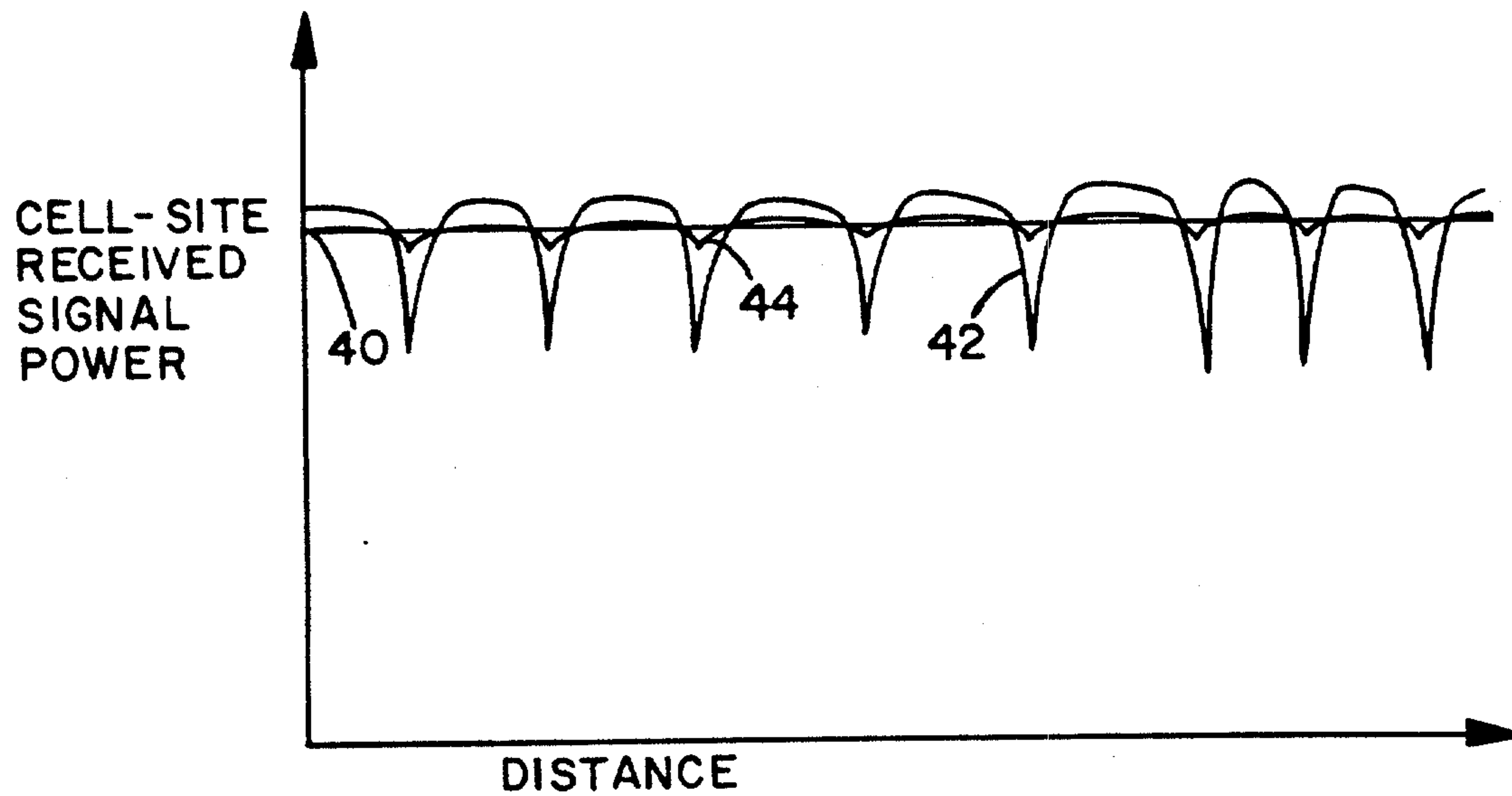

FIG. 2D

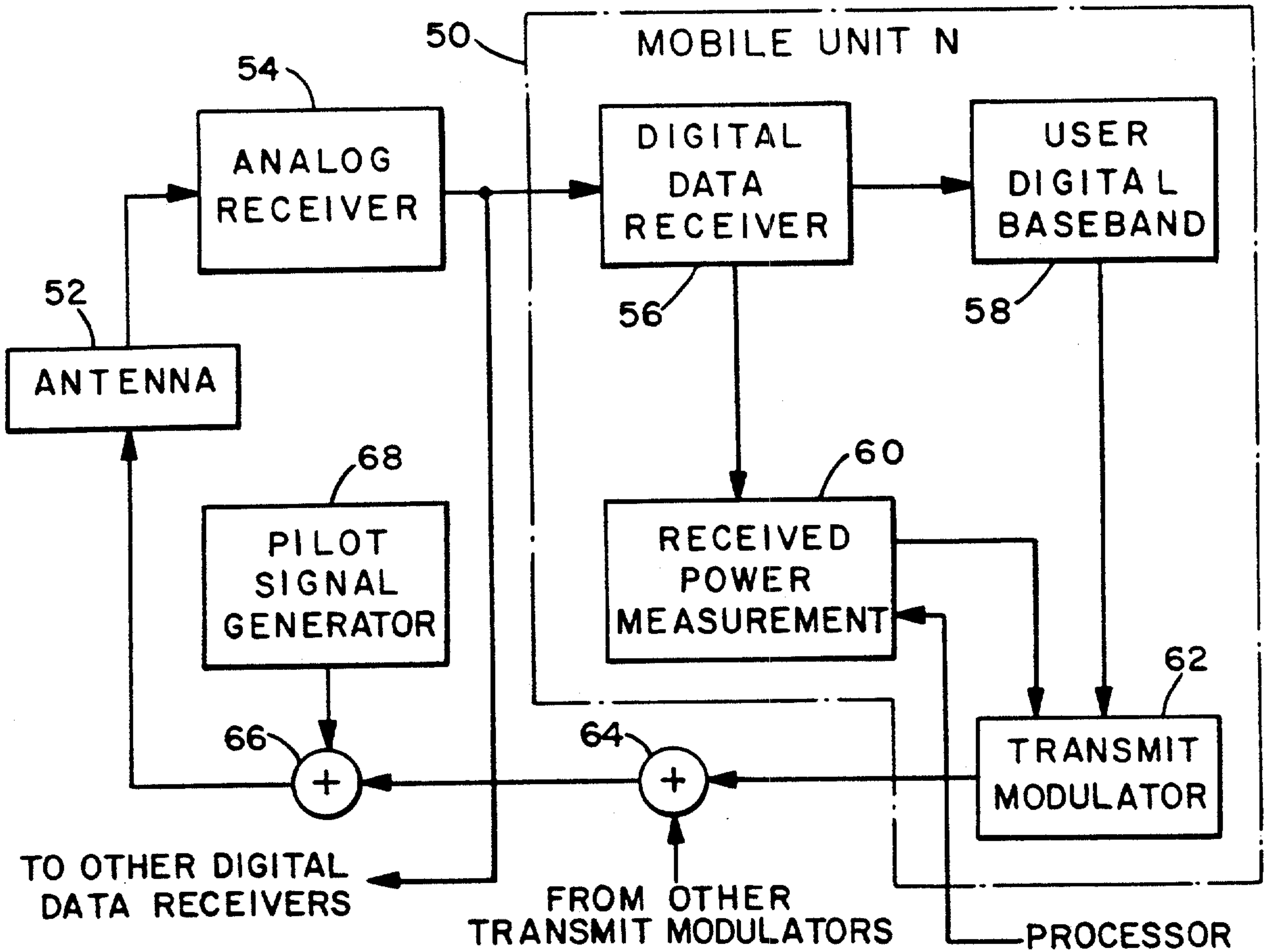

FIG. 3

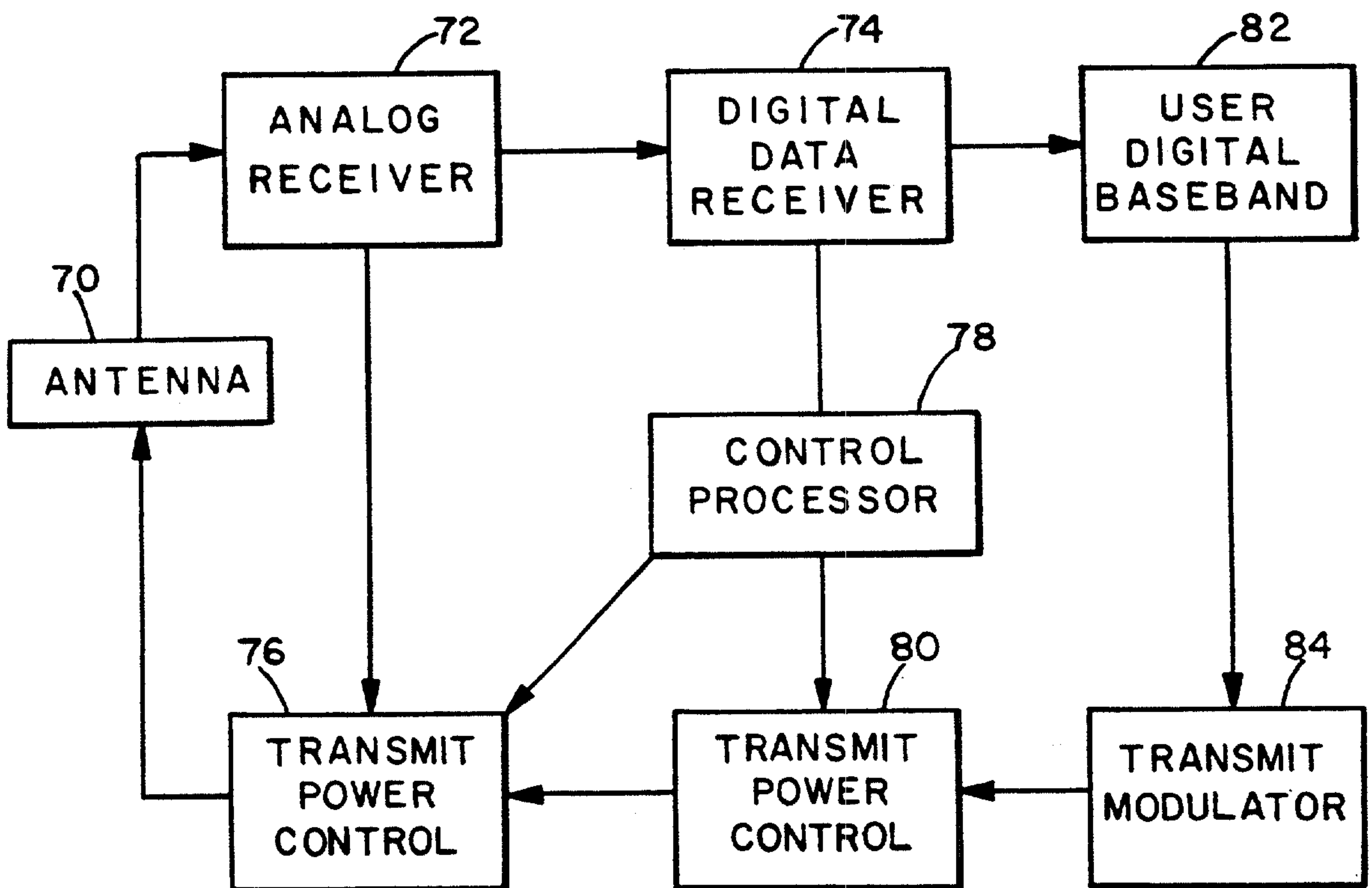

FIG. 4

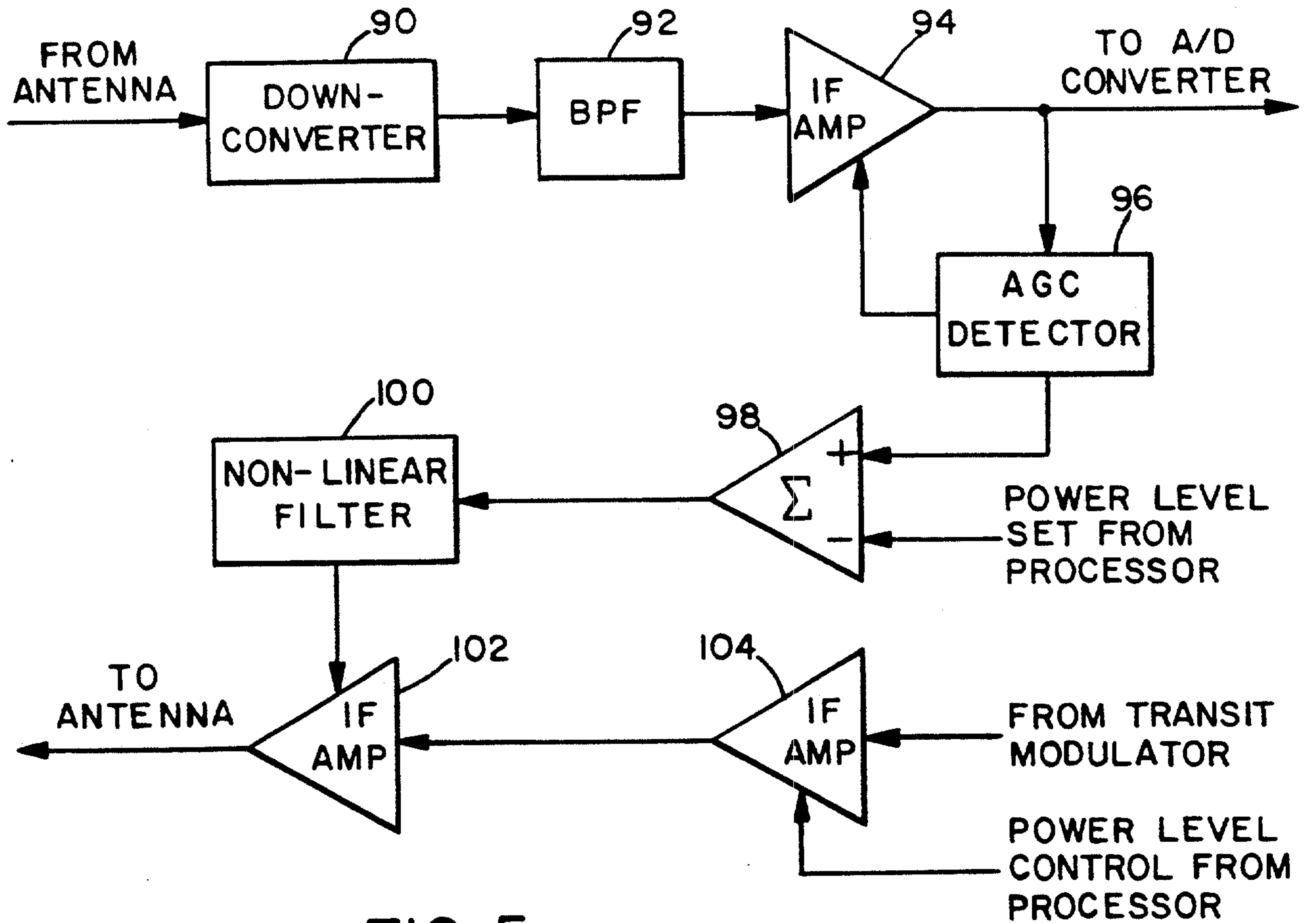

FIG. 5

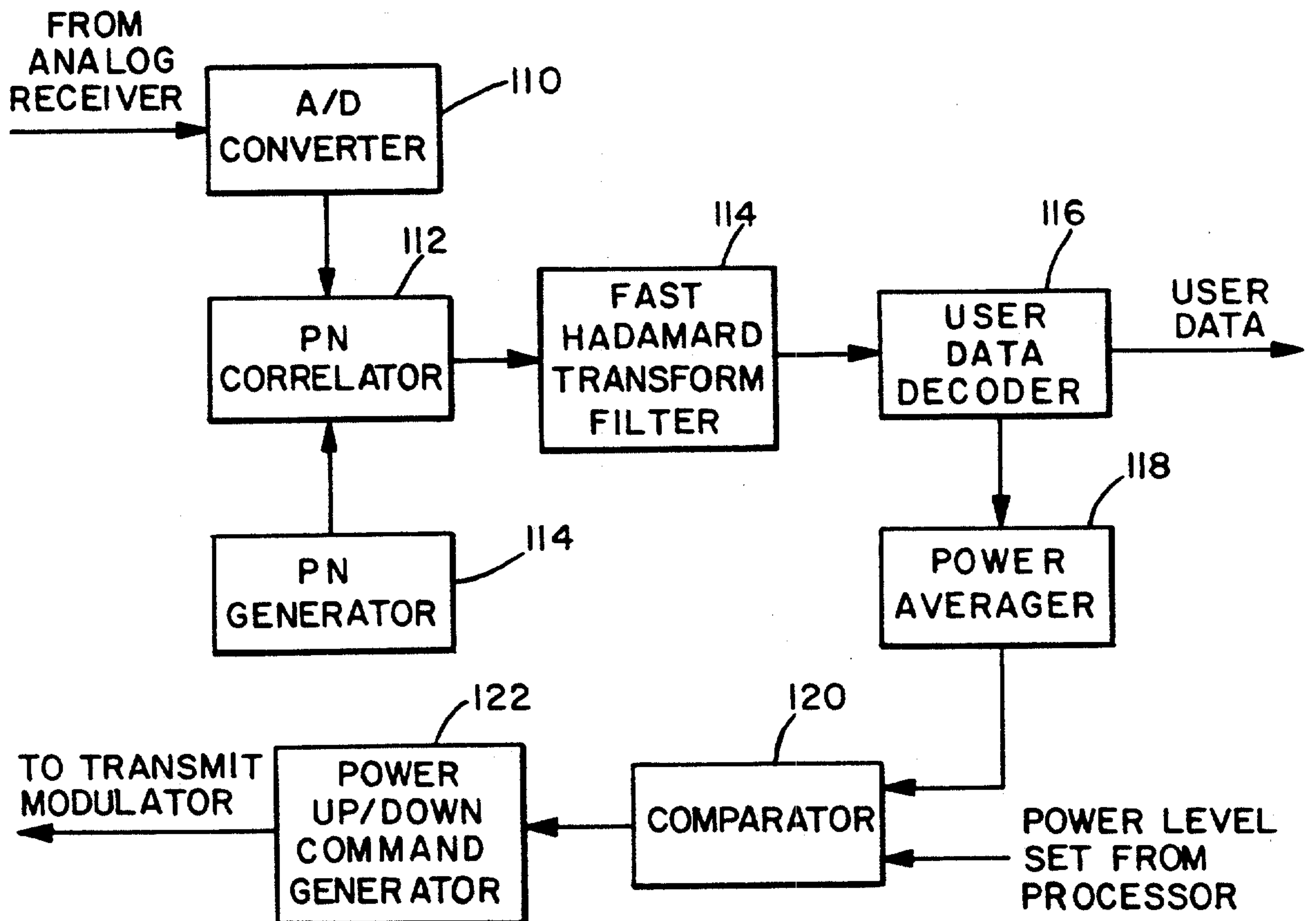

FIG. 6

