

(12) PATENT
(19) AUSTRALIAN PATENT OFFICE

(11) Application No. AU 199749694 B2
(10) Patent No. 714355

(54) Title
Pressure vessel assembly

(51)⁶ International Patent Classification(s)
F02M 037/10 B60K 015/05

(21) Application No: 199749694 (22) Application Date: 1997 .11 .07

(87) WIPO No: W098/20247

(30) Priority Data

(31) Number	(32) Date	(33) Country
1004471	1996 .11 .07	NL

(43) Publication Date : 1998 .05 .29
(43) Publication Journal Date : 1998 .07 .23
(44) Accepted Journal Date : 1999 .12 .23

(71) Applicant(s)
Vialle Beheer B.V.

(72) Inventor(s)
Servatius Alfons Maria Jaasma; Marcus Johannes Petrus Gerardus Den Hartog

(74) Agent/Attorney
COLLISON and CO,GPO Box 2556,ADELAIDE SA 5001

(56) Related Art
EP 42887
DE 9411124

OPI DATE 29/05/98 APPLN. ID 49694/97
AOJP DATE 23/07/98 PCT NUMBER PCT/NL97/00610



AU9749694

IN

<p>(51) International Patent Classification ⁶ : F02M 37/10, B60K 15/05</p>	<p>A1</p>	<p>(11) International Publication Number: WO 98/20247 (43) International Publication Date: 14 May 1998 (14.05.98)</p>
<p>(21) International Application Number: PCT/NL97/00610 (22) International Filing Date: 7 November 1997 (07.11.97) (30) Priority Data: 1004471 7 November 1996 (07.11.96) NL (71) Applicant (for all designated States except US): VIALLE BEHEER B.V. [NL/NL]; P.O. Box 150, NL-5620 AD Sen (NL), P.O. Box 28060, NL-5002 JB Eindhoven, The Netherlands (72) Inventors; and (75) Inventors/Applicants (for US only): JAASMA, Servatius, Alfons, Maria [NL/NL]; Finisterlaan 47, NL-5627 TE Eindhoven (NL), DEN HARTOG, Marcus, Johannes, Petrus, Gerardus [NL/NL]; Koningskinderen 11, NL-5629 KC Eindhoven (NL). (74) Agent: DE BRUIJN, Leendert, C.; Nederlandsch Octrooibureau, Scheveningseweg 82, P.O. Box 29720, NL-2502 LS The Hague (NL).</p>		<p>(81) Designated States: AL, AM, AT, AU, AZ, BA, BB, BG, BR, BY, CA, CH, CN, CU, CZ, DE, DK, EE, ES, FI, GB, GE, GH, HU, ID, IL, IS, JP, KE, KG, KP, KR, KZ, LC, LK, LR, LS, LT, LU, LV, MD, MG, MK, MN, MW, MX, NO, NZ, PL, PT, RO, RU, SD, SE, SG, SI, SK, SL, TJ, TM, TR, TT, UA, UG, US, UZ, VN, YU, ZW, ARIPO patent (GH, KE, LS, MW, SD, SZ, UG, ZW), Eurasian patent (AM, AZ, BY, KG, KZ, MD, RU, TJ, TM), European patent (AT, BE, CH, DE, DK, ES, FI, FR, GB, GR, IE, IT, LU, MC, NL, PT, SE), OAPI patent (BF, BJ, CF, CG, CI, CM, GA, GN, ML, MR, NE, SN, TD, TG).</p> <p>Published With international search report. In English translation (filed in Dutch).</p> 

(54) Title: PRESSURE VESSEL ASSEMBLY

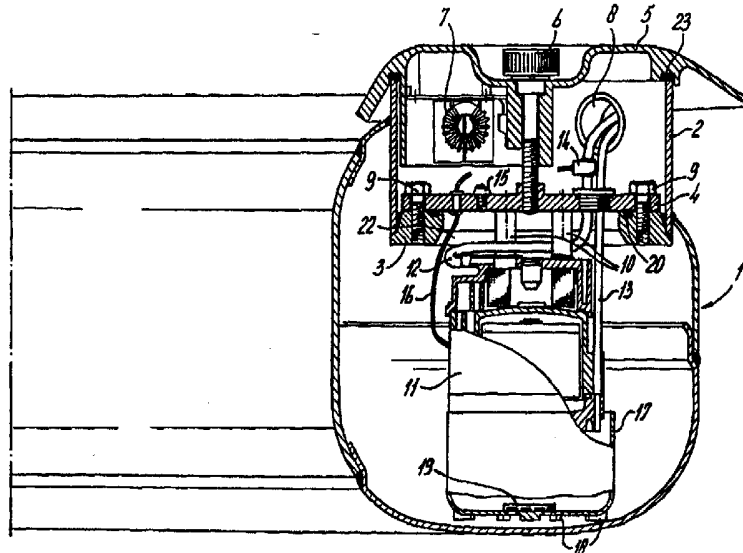

(57) Abstract

Pressure vessel assembly comprising an accessories plate in the form of a flange. All connections to the inside of the pressure vessel (1) are fitted on said accessories plate (4). The pressure vessel (1) is also provided with a fuel pump (11), and said fuel pump is suspended from the accessories plate (4). Fixing to the accessories plate (4) is by means of so-called silent blocks (10).

PCT/NL 97/00610

Pressure vessel assembly

The present invention relates to a pressure vessel assembly according to the preamble of claim 1.

5 Such a pressure vessel assembly is known from DE- 94 11 124 U 1. In the
- case of conventional pressure vessels such as those for holding LPG a plate
is welded onto a part of the wall thereof, in order to achieve a greater
wall thickness in this way. Holes are tapped in said wall, and the various
inlets, outlets and the like are fitted thereon. Since this is a relatively
10 complex method, it is proposed in the above prior art to provide such a so-
called accessories plate as a separate part and attach it to the tank by
means of a seal. In this way the accessories plate with parts mounted
thereon can be fitted in the tank in a single operation. This is important
particularly if a complex float device for the filling level is fitted.

15 Such an accessories plate is preferably designed for a system with
single line, in the case of which liquefied gas under pressure is supplied
to an internal combustion engine and combusted there. However, a recent
development makes use of an injection system for LPG in which a fuel pump
is used and a return line is present, inter alia, in order to ensure that
20 liquefied gas is constantly present in the injection lines concerned. In
this case it is essential for such a pump to operate as far as possible in
excess pressure, because when negative pressure is created during the
suction of the liquefied gas there is a danger of this gas passing into
vapour form. For that reason, every effort is made to fit such a pump at
25 the bottom of a pressure vessel if possible. However, this entails
drawbacks as regards design, because a top opening of considerable size
must be present. Another problem is that tanks with different dimensions
are used, depending on the type of vehicle.

DE-94 11 124 describes a fuel tank for motor vehicles in which the fuel
30 pump is mounted inside the tank through a spring loaded structure support-
ing on the other hand on a vertical mounting rod suspended from the top
wall of the tank.

35

Replacement page 1 dated January 15, 1999



AMENDED SHEET

1a

The object of the present invention is to provide a pressure vessel assembly in the case of which the fuel pump is easy to fit, and in the case of which it is always ensured that such a fuel pump is situated near the bottom of the vessel.

5

Therefore, according to the invention there is provided a pressure vessel assembly for fuel, comprising a pressure vessel with an opening (22) and a flanged plate (4) to be fitted thereon, which flanged plate is provided with a number of connections, comprising a fuel outlet (12) from the vessel, a fuel pump (11) being present in the vessel, which fuel pump is suspended from the flanged plate solely by way of spacer means (10) of a length to be selected, said length being selected in such a way that the underside of the fuel pump is situated near the bottom of the vessel, characterised in that in the opening (22) a pipe section (2) is welded, the end of which pipe section facing the inside of the vessel being provided with a flanged edge carrying the flanged plate and in which the end facing away from the inside of the vessel can be provided with a cover (5), said flanged plate comprising filling line (21) and blow-off safety valve (15), and a fuel return line element (13).

10

15

20

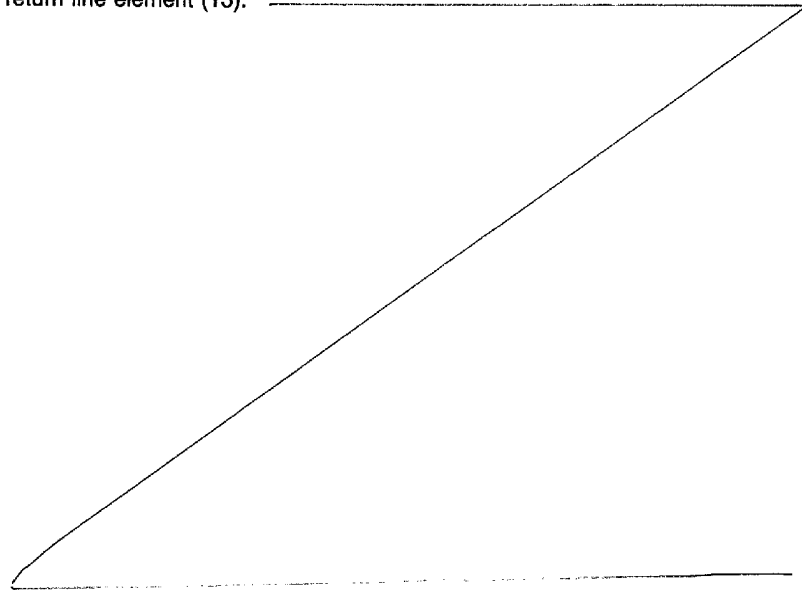
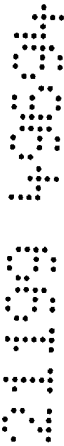

plate solely by way of exchangeable spacer means of a length to be selected, said length being selected in such a way that the underside of the fuel pump is situated near the bottom, while the accessories plate is provided with a fuel return line element.

5 The invention is based on the idea of using the removable accessories plate known in the prior art. This produces a relatively large opening which can be used in a particularly effective way for allowing through the fuel pump. Contrasting with earlier proposals, the fuel pump is not fixed to the bottom of the vessel, but to the
10 accessories plate, so that it is possible to mount everything in advance. This is important in particular for the coupling of pipes, but spacers are used between the accessories plate and the fuel pump, in order to provide an adaptation to different (height) dimensions of the tanks. If
15 these spacers are in the form of vibration-damping elements such as silent blocks, the advantage obtained here is that the noise of the pump is insulated as much as possible relative to the environment.

 The accessories plate can be combined in any way known in the prior art with the box which has to be fitted thereon as a compulsory measure in many countries. Such a box is an additional safety measure
20 which prevents gas from escaping to, for example, the boot of the car if there is leakage between the accessories plate and the various accessories fitted thereon. For this purpose, a gastight box which is in communication by way of an outlet with the outside of the vehicle,
25 preferably the underside, is stipulated. In the event of any leakage, the gas in question will escape to the outside of the vehicle, so that the risk of explosion during starting and the like is largely removed. Such an accessories box in the prior art is a separate expensive casting which has to be fitted by complicated steps.

 According to one object of the invention, use of such a complex
30 accessories box is avoided by the fact that the pressure vessel comprises a circular opening which is made in the pressure vessel and in which a pipe section is welded, the end of which pipe section facing the inside of the vessel being provided with the flanged edge, and in which the end facing away from the inside of the vessel can be provided with a cover,
35 i.e. the construction for the accessories plate is effectively combined with the box described above.

 The now very simply designed cover can be used in particular for the accommodation of electronic components. This cover is a relatively cool part and provides such components with sufficient

protection. Such electronic components comprise in particular circuits relating to the control of the pump.

Although the pump can comprise any construction known in the prior art, it is preferably provided with a buffer element fitted in its vicinity. LPG can be stored in said buffer element, and in particular if the tank is almost empty, the presence of the buffer element ensures that the pump does not suck up vapour instead of liquefied gas. A non-return valve is preferably fitted in the buffer element, so that material can only enter the buffer element. The buffer element can be made of a relatively flexible material which can adapt to the local conditions.

According to a further advantageous embodiment, the fuel return line opens out into the buffer element, so that when the pressure vessel is just about empty it is ensured that liquid is sucked up as long as possible. The good heat conduction will mean that the slightly warmer liquid from the return line is cooled immediately, before being pumped back by the fuel pump described above.

The invention will be explained in greater detail below with reference to an exemplary embodiment shown in the drawing, in which:

Fig. 1 shows a side view in cross-section of an embodiment of the pressure vessel assembly according to the invention; and

Fig. 2 shows a top view of the part near the pipe 2 according to Fig. 1 with the various accessories.

A pressure vessel is indicated by 1 in the figures. Said pressure vessel is provided with an opening (not shown in any further detail) in which a pipe 2 is fitted in a gastight manner by welding. Said pipe 2 is provided with a flanged edge 3 on the side facing the inside of the tank. On the other side, said pipe is dimensioned in such a way that a cover 5 can be placed over it and can be tightened by means of a bolt 6. An O-ring 23 is present between cover 5 and pipe 2. Flanged edge 3 is designed for receiving a flanged plate 4 thereon. An O-ring 20 provides for the seal, while fixing is achieved by means of bolts 9. Flanged plate 4 is in the form of an accessories plate, on which the usual accessories of an LPG tank for a motor vehicle are situated. These are an inlet 12 provided with a shut-off valve 14, a return line 13, a release valve 15 and wiring 16 and filling line 21. Wiring 16 is used for the control of the fuel pump indicated by 11. Fuel pump 11 is fixed on accessories plate 4 by means of vibration-damping elements such as silent blocks 10. Three of such silent blocks are present in the case of the embodiment shown here. The height of the silent blocks, i.e. the distance from the fuel

pump 11 to the accessories plate 4, is selected in such a way that the underside of the fuel pump is situated close to the bottom of the pressure vessel 1. This is important because negative pressure, which could lead to vaporization of the LPG present in the fuel pump, has to be prevented from occurring therein. Provision can be made for adaptations for tanks with different heights by using silent blocks of greater or smaller height. In this way it is always guaranteed that the underside of the pump is situated as close as possible to the bottom of the pressure vessel. Of course, a construction can be fitted in the pressure vessel to prevent the pressure vessel from being filled to more than the legal percentage. Fuel pump 11 is not shown in any further detail, but contains filters and the like in the usual way. On the underside the fuel pump 11 is provided with bellows 17 which surround it and act as a buffer. Said bellows are made of a slightly flexible material, of which a number of "feet" 18 rest on the bottom of the tank. Slight tolerances can be accommodated because of the flexible nature of the material. This means that the buffer will always touch the bottom with the flexible sound-damping material, while the pump is always suspended from the accessories plate by way of the silent blocks described above. Maximum sound insulation is consequently obtained and, on the other hand, optimum emptying of the vessel is ensured. Buffer 17 is provided on the underside with an inlet valve 19 which functions as a one-way valve. This ensures that when the tank is almost empty and bends are being negotiated, LPG situated in the buffer can flow back into an empty part of the pressure vessel.

The construction shown here makes it possible in a simple manner to fix together the assembly consisting of accessories plate and pump and fit the tank in one operation. This contrasts with the prior art, in which it was necessary to fix the pump on the bottom of the pressure vessel by an extremely complicated operation.

Although the invention is described with reference to a preferred embodiment, it must be understood that numerous modifications can be made to it without going beyond the scope of the appended claims.

CLAIMS DEFINING THE INVENTION ARE AS FOLLOWS:

1. Pressure vessel assembly for fuel, comprising a pressure vessel with an opening (22) and a flanged plate (4) to be fitted thereon, which flanged plate is provided with a number of connections, comprising a fuel outlet (12) from the vessel, a fuel pump (11) being present in the vessel, which fuel pump is suspended from the flanged plate solely by way of spacer means (10) of a length to be selected, said length being selected in such a way that the underside of the fuel pump is situated near the bottom of the vessel, characterised in that in the opening (22) a pipe section (2) is welded, the end of which pipe section facing the inside of the vessel being provided with a flanged edge carrying the flanged plate and in which the end facing away from the inside of the vessel can be provided with a cover (5), said flanged plate comprising filling line (21) and blow-off safety valve (15), and a fuel return line element (13).
2. Pressure vessel assembly according to claim 1, wherein said spacer means comprise vibration-damping means.
3. Pressure vessel assembly according to one of the preceding claims, provided with a cover, wherein electronic components (7) are accommodated in said cover.
4. Pressure vessel assembly according to one of the preceding claims, in which the pump comprises a buffer container (17) fitted near the bottom end thereof.
5. Pressure vessel assembly according to claim 4, in which said buffer container is made of a flexible material and is of such a length when not deformed that in the fitted position one end thereof rests against the bottom of the vessel.
6. Pressure vessel assembly according to claim 4 or 5, in which said buffer container is provided with an inlet valve (10).



7. Pressure vessel assembly according to one of claims 4-6, in which the fuel return line element opens out into said buffer container.

5

Dated this 2nd day of November 1999

VIALLE BEHEER B.V.
By their Patent Attorneys

10 COLLISON & CO

5
5
5
5



fig-1

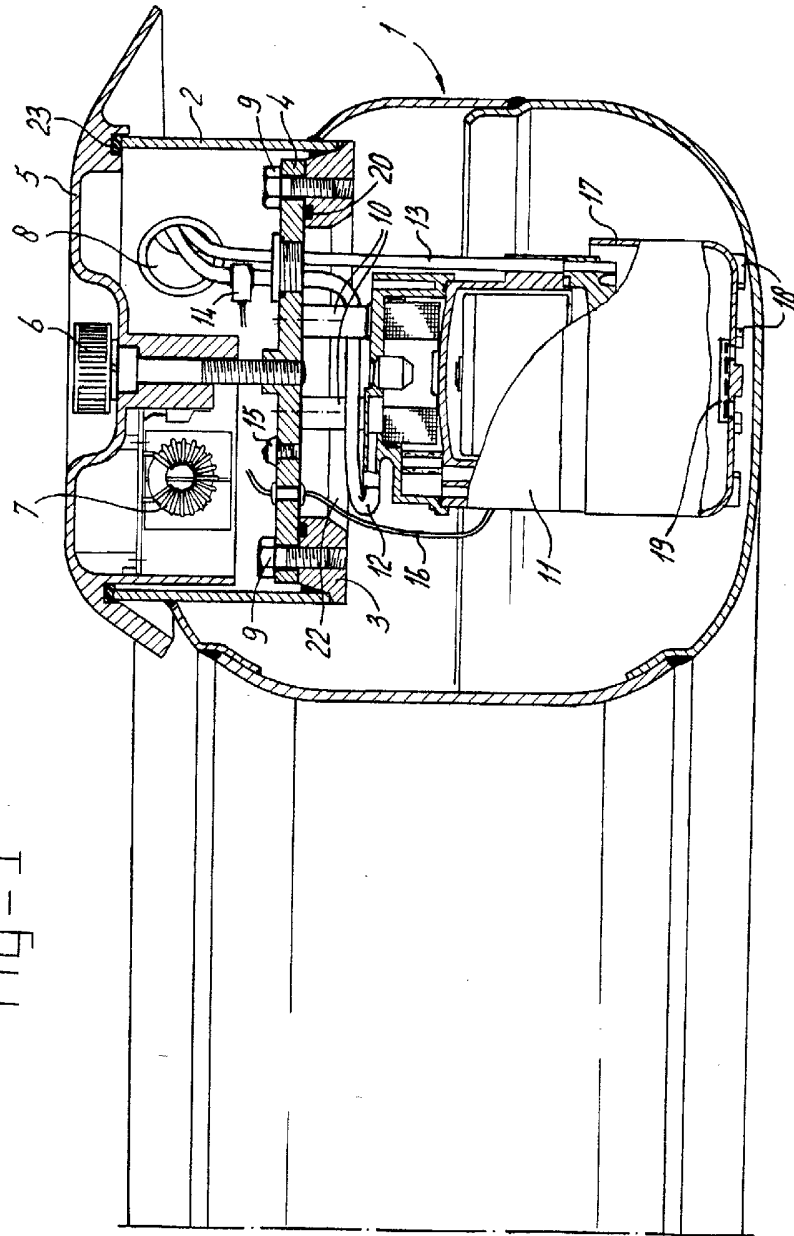

Fig-2

