

J. I. KNIGHT.

MACHINE FOR APPLYING BINDING STRIPS TO BOOKS.

No. 522,423.

Patented July 3, 1894.

Fig. 1.

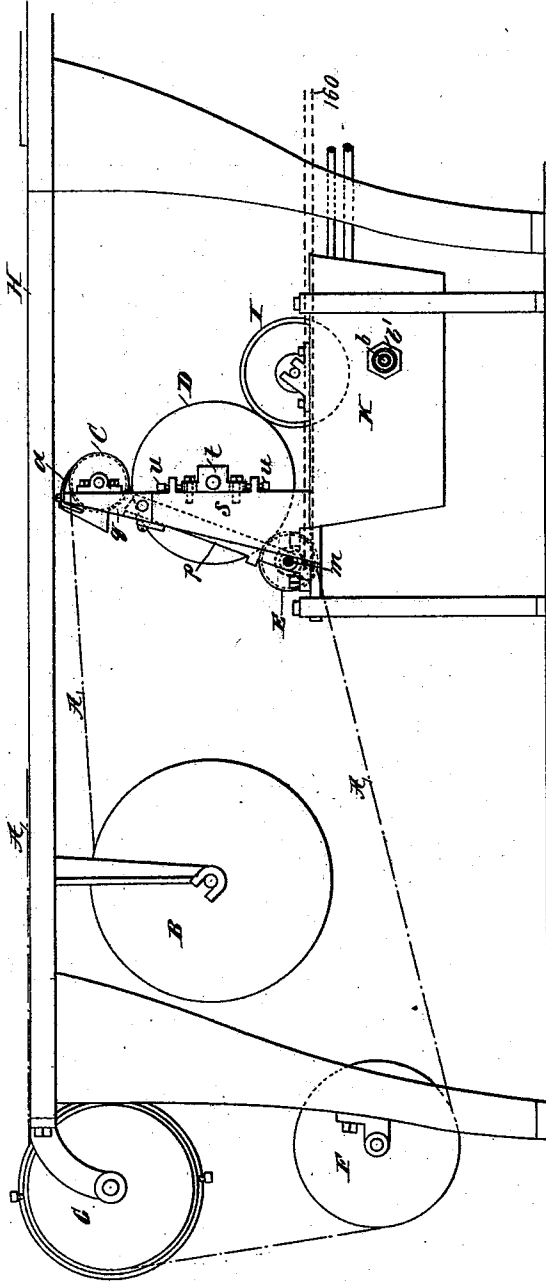

Attest:
L. H. White
C. J. Sawyer

Inventor:
Joseph I. Knight
By Philip H. Henshaw, Clerk
H. H. H.

(No Model.)

13 Sheets—Sheet 2.

J. I. KNIGHT.

MACHINE FOR APPLYING BINDING STRIPS TO BOOKS.

No. 522,423.

Patented July 3, 1894.

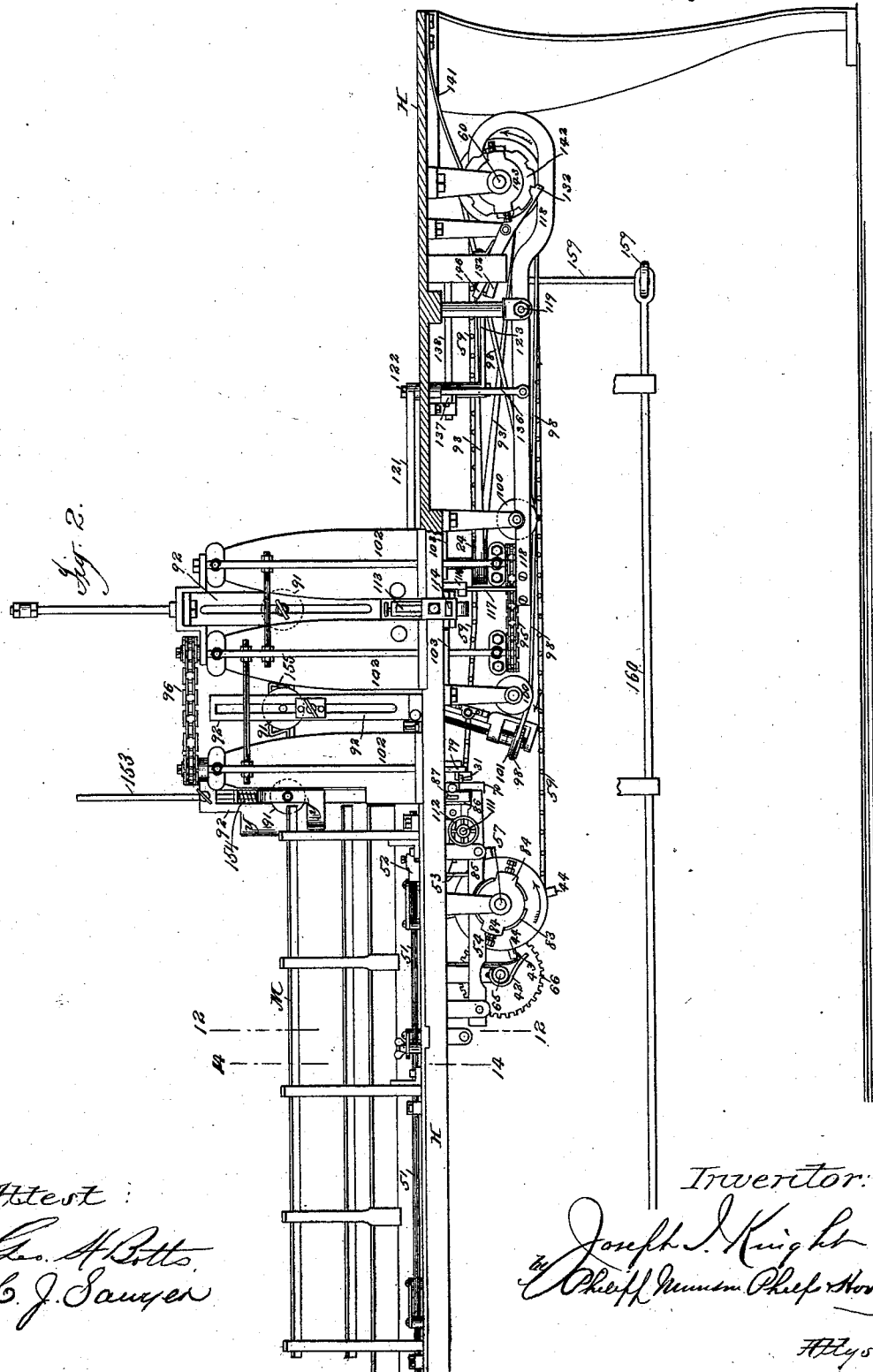

Attest:
Geo. H. Batts.
C. J. Sawyer

Inventor:
Joseph I. Knight
By Philip Munson, Philip Henry
 Attys

J. I. KNIGHT.

MACHINE FOR APPLYING BINDING STRIPS TO BOOKS.

No. 522,423.

Patented July 3, 1894.

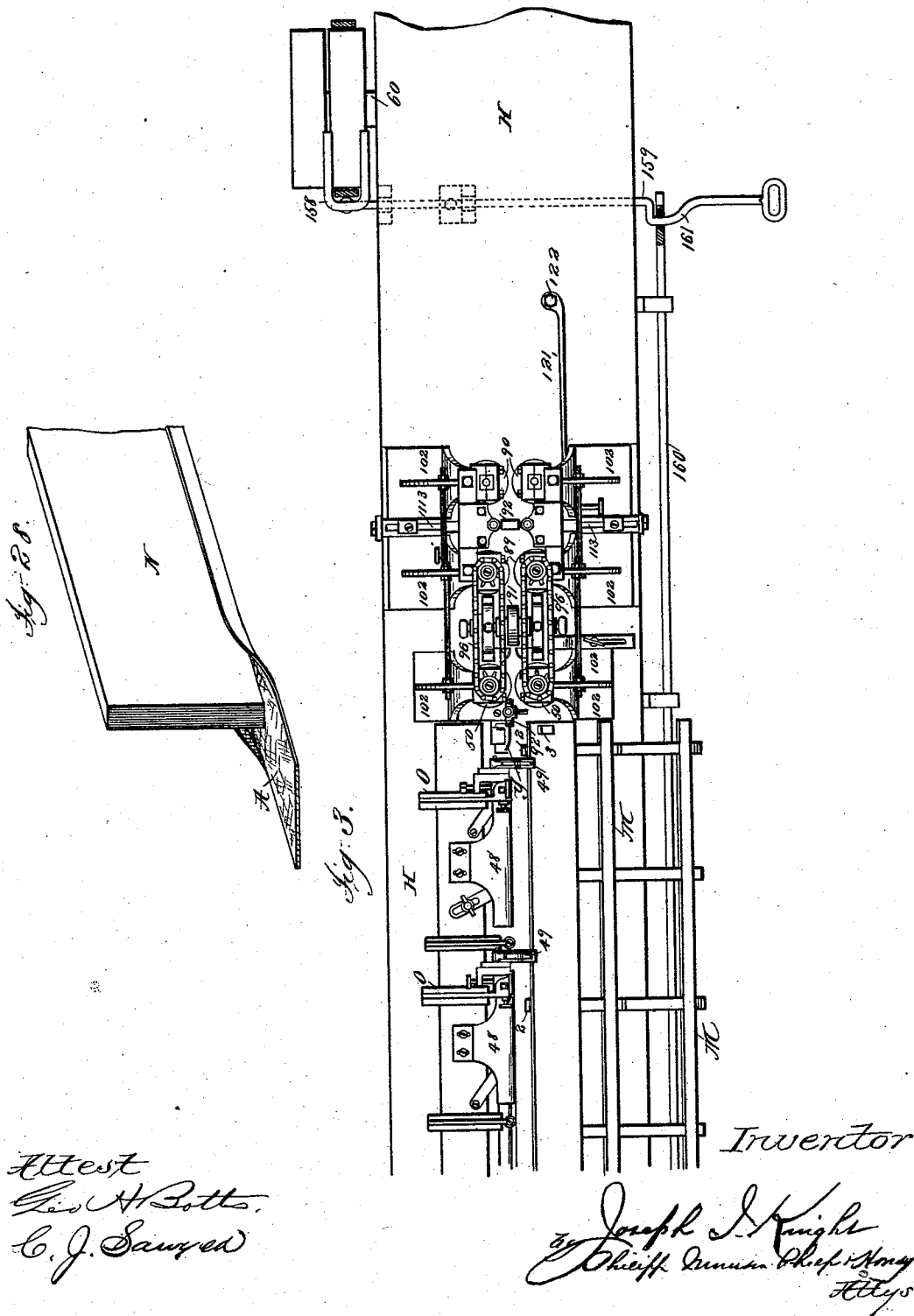

Attest
 Geo. H. Botta,
 C. J. Sawyer

Inventor
 J. I. Knight
 by Joseph I. Knight
 Chief Clerk
 Atty

(No Model.)

13 Sheets—Sheet 4.

J. I. KNIGHT.

MACHINE FOR APPLYING BINDING STRIPS TO BOOKS.

No. 522,423.

Patented July 3, 1894.

Fig. 4.

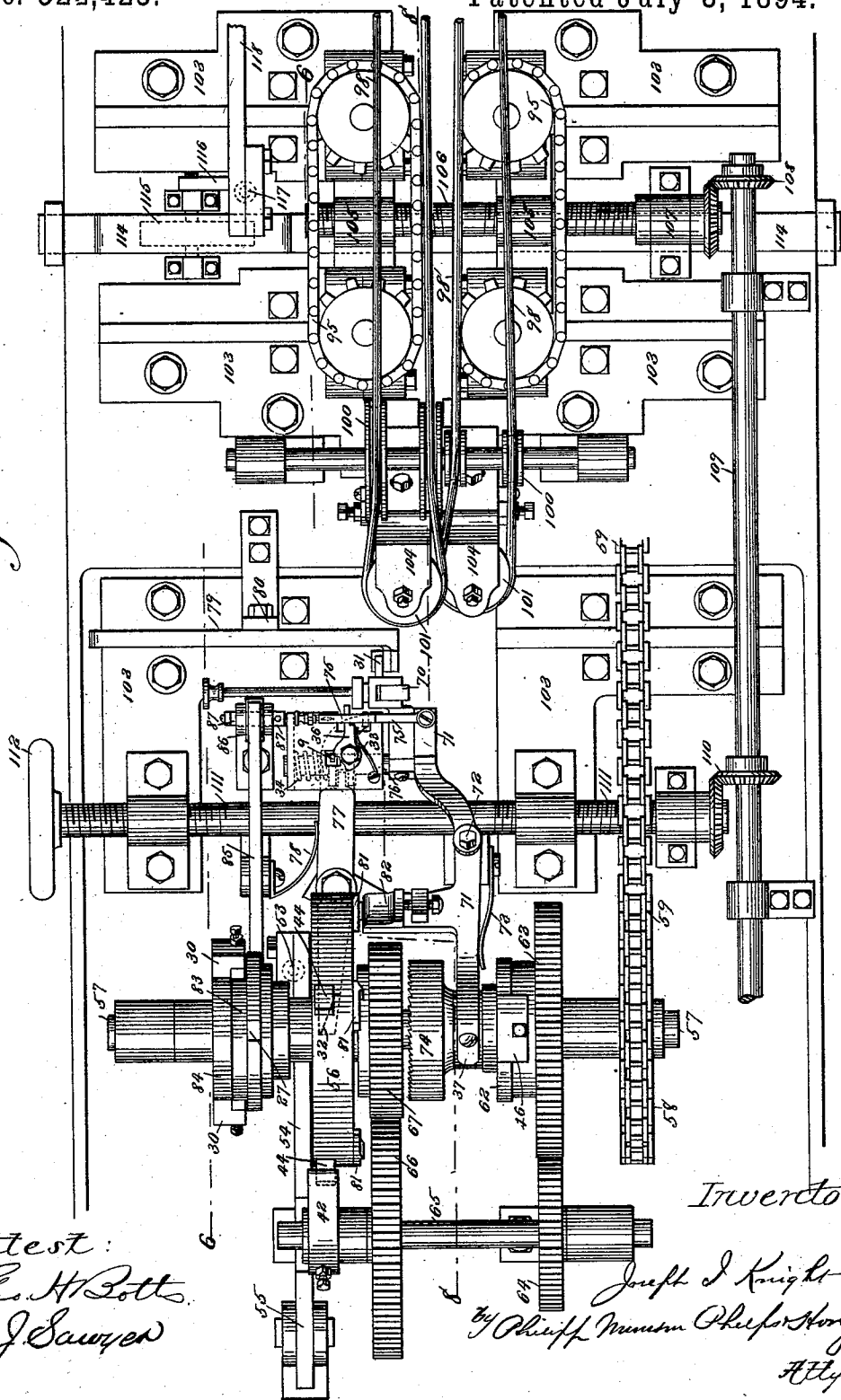

Inventor

Joseph I. Knight

By *Phieff. Munson Phelps*

Attys

Attest:
Chas. H. Potts
C. J. Sawyer

J. I. KNIGHT.

MACHINE FOR APPLYING BINDING STRIPS TO BOOKS.

No. 522,423.

Patented July 3, 1894.

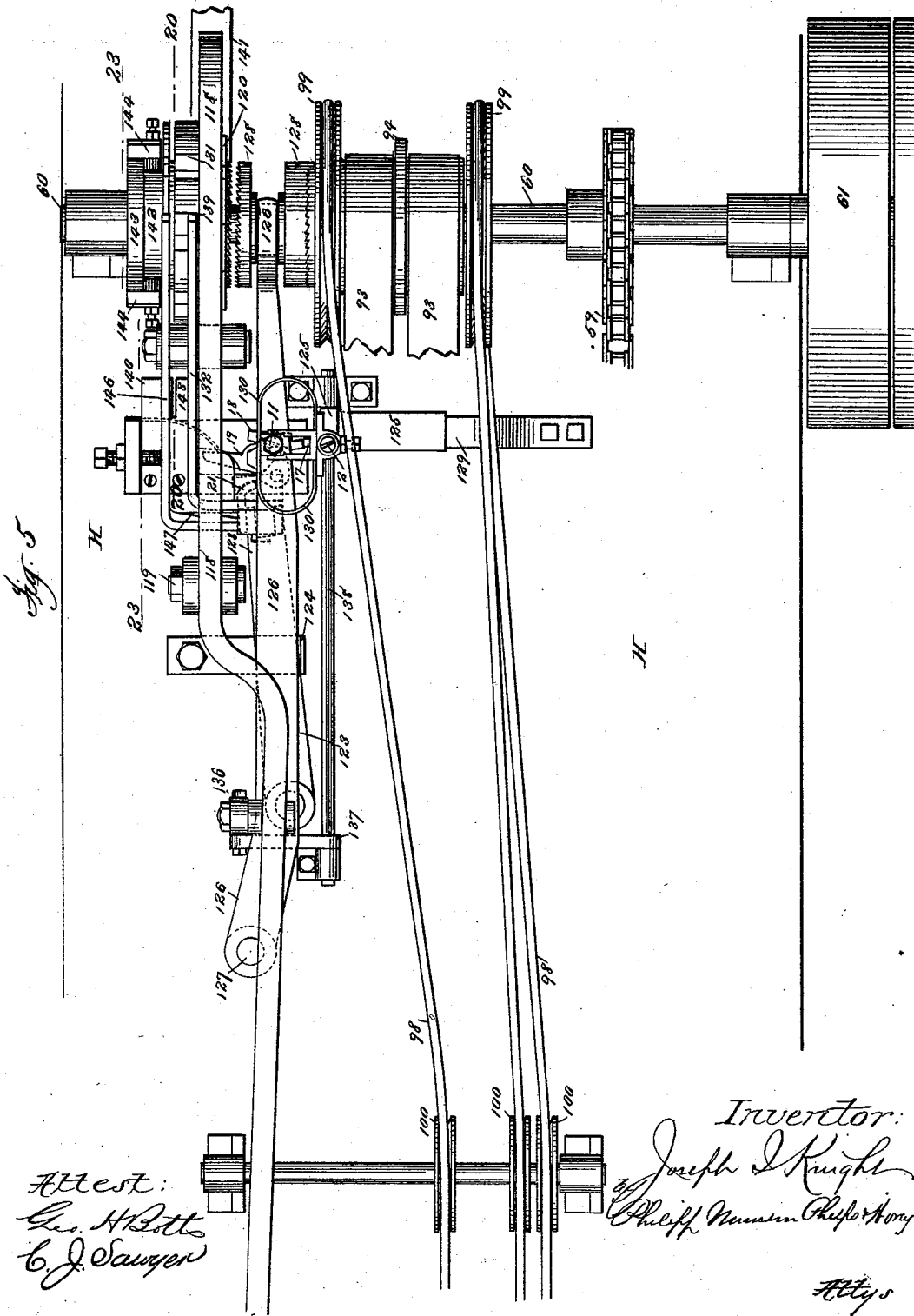

Attest:
Geo. H. Bette
C. J. Sawyer

Inventor:
Joseph I. Knight
Chief Examiner
Dep't. of Com.

Atty's

J. I. KNIGHT.

MACHINE FOR APPLYING BINDING STRIPS TO BOOKS.

No. 522,423.

Patented July 3, 1894.

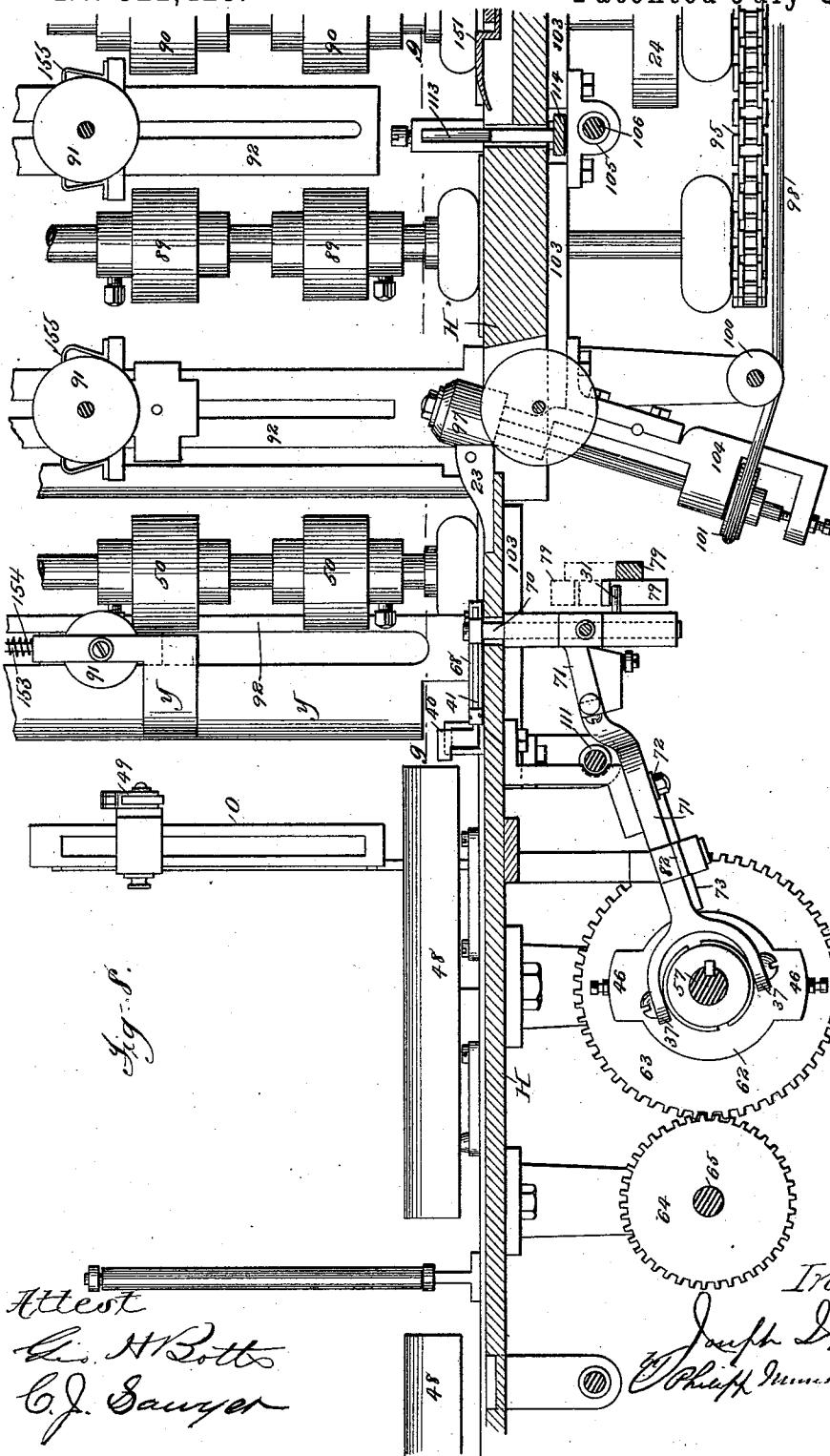

Fig. 8.

Attest
Chas. H. Botts
C. J. Sawyer

Inventor
Joseph I. Knight
Chief Mechanic

Atty

J. I. KNIGHT.

MACHINE FOR APPLYING BINDING STRIPS TO BOOKS.

No. 522,423

Patented July 3, 1894.

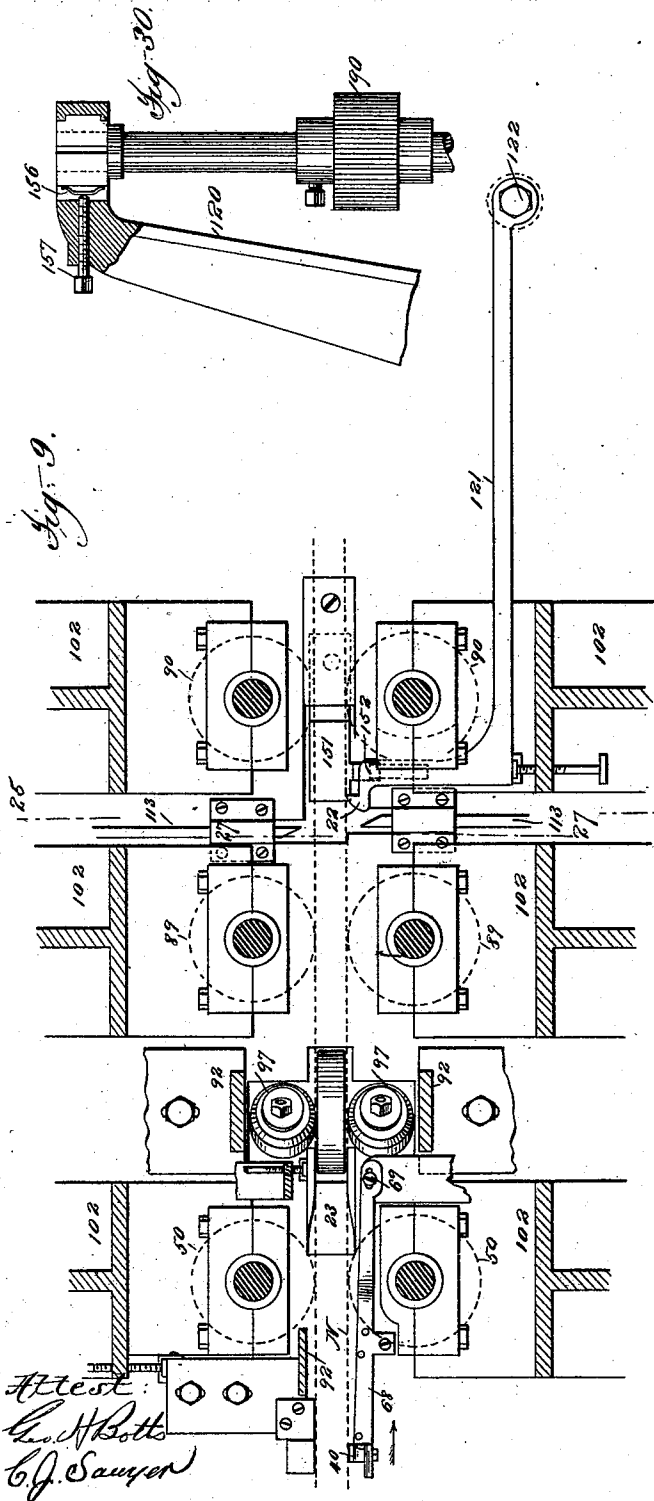

Fig. 9.

Attest:
Geo. H. Botts
C. J. Sawyer

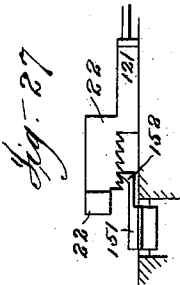

Fig. 27.

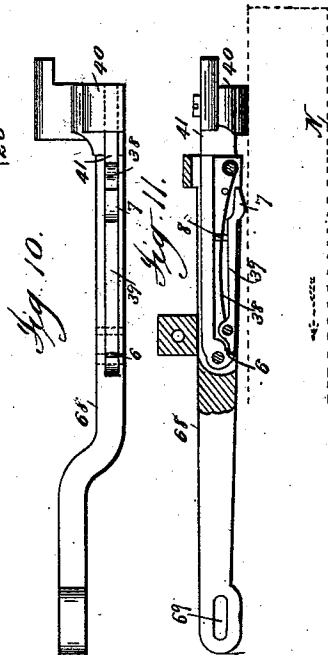

Fig. 10.

Fig. 11.

Inventor
Joseph I. Knight
by Chief Clerk Ralph H. Hony

Attest

J. I. KNIGHT.

MACHINE FOR APPLYING BINDING STRIPS TO BOOKS.

No. 522,423.

Patented July 3, 1894.

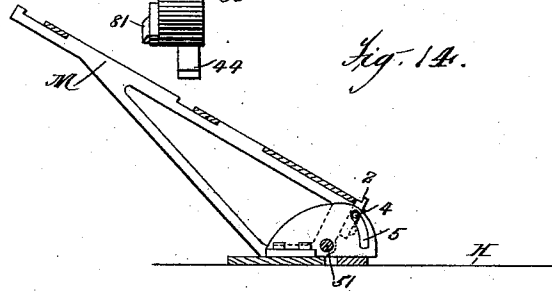
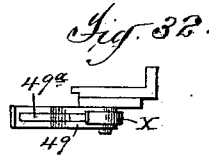
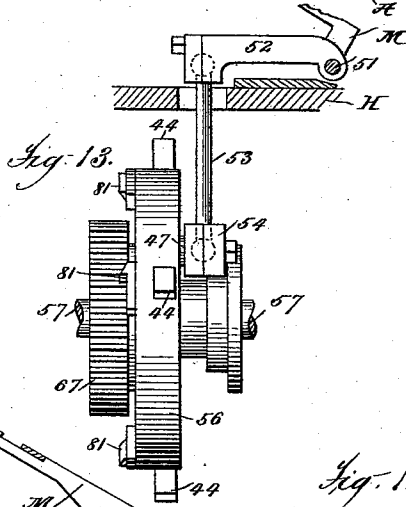
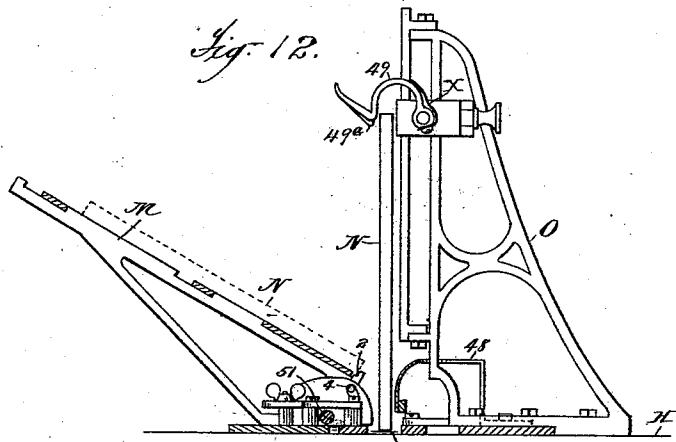

Attest:
 Geo. H. Roberts
 C. J. Sawyer

Inventor:
 Joseph I. Knight
 by Philip M. ...

Atty

J. I. KNIGHT.

MACHINE FOR APPLYING BINDING STRIPS TO BOOKS.

No. 522,423.

Patented July 3, 1894.

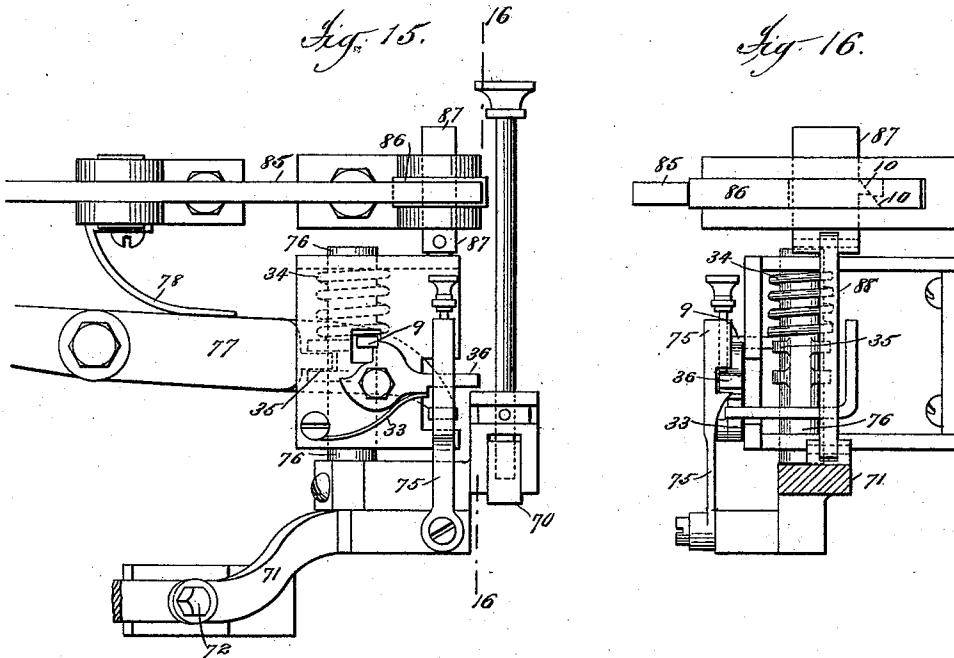

Fig. 31.

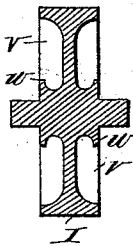
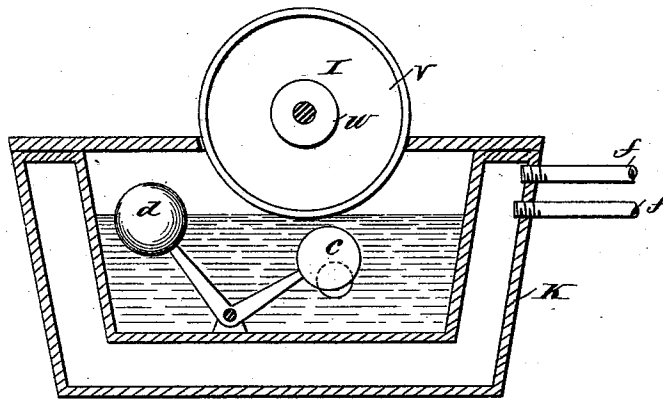

Fig. 19.



Attest
 Geo. H. Potts
 C. J. Sawyer

Inventor:
 Joseph I. Knight
 by Chas. J. Sawyer

Attys

(No Model.)

13 Sheets—Sheet 11.

J. I. KNIGHT.

MACHINE FOR APPLYING BINDING STRIPS TO BOOKS.

No. 522,423.

Patented July 3, 1894.

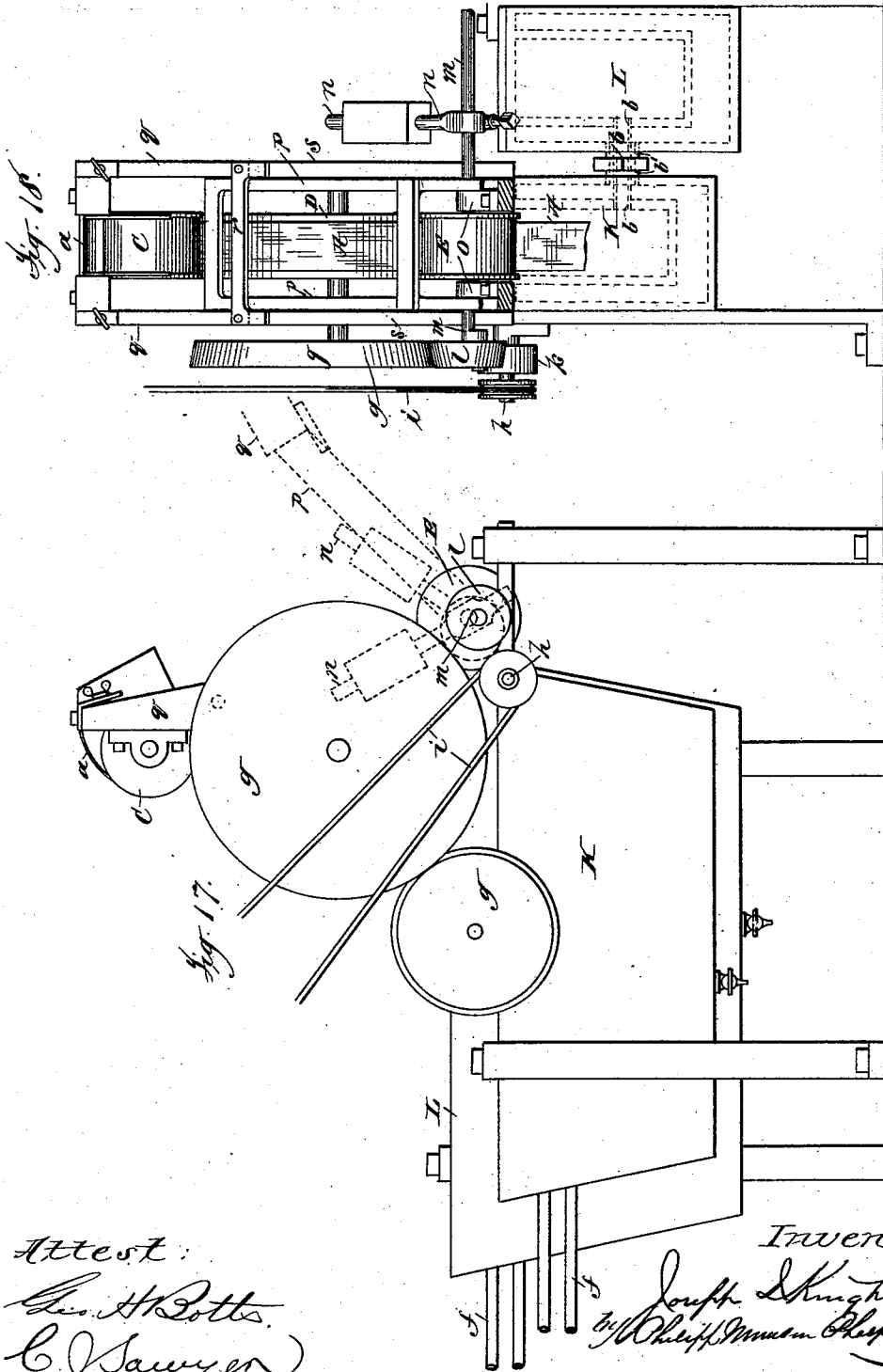

Attest:
Geo. H. Potts,
C. J. Sawyer

Inventor:
Joseph I. Knight
by Charles Munson Clerk

Atty's

(No Model.)

13 Sheets—Sheet 13.

J. I. KNIGHT.

MACHINE FOR APPLYING BINDING STRIPS TO BOOKS.

No. 522,423.

Patented July 3, 1894.

Fig. 25.

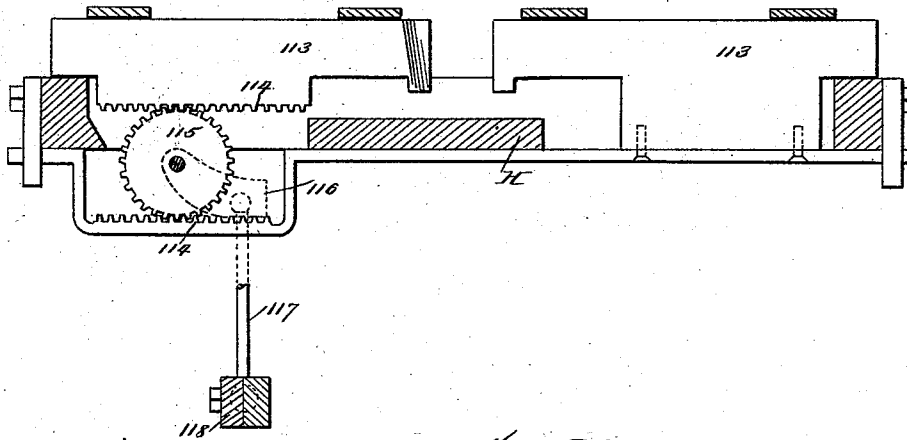

Fig. 24.

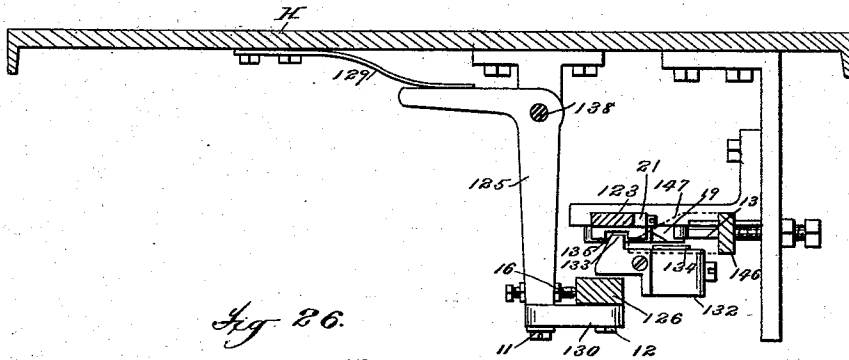
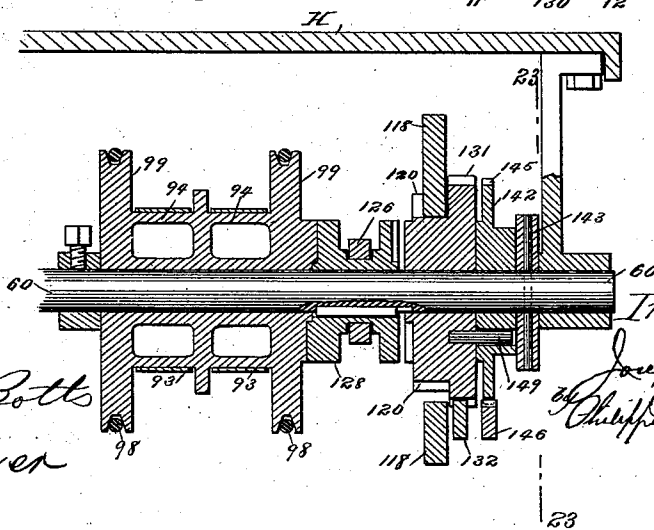

Fig. 26.



Attest:
G. H. Botts
C. J. Sawyer

Inventor:
Joseph I. Knight
Charles M. Phelps & Henry

Attys

UNITED STATES PATENT OFFICE.

JOSEPH I. KNIGHT, OF BROOKLYN, NEW YORK.

MACHINE FOR APPLYING BINDING-STRIPS TO BOOKS.

SPECIFICATION forming part of Letters Patent No. 522,423, dated July 3, 1894.

Application filed July 30, 1891. Renewed August 1, 1892. Serial No. 441,845. (No model.)

To all whom it may concern:

Be it known that I, JOSEPH I. KNIGHT, a citizen of the United States, residing at Brooklyn, county of Kings, and State of New York, have invented certain new and useful Improvements in Machines for Applying Binding-Strips to Books, fully described and represented in the following specification and the accompanying drawings, forming a part of the same.

This invention relates to a machine by which a number of leaves or sheets of paper either piled flat one upon another or folded into signatures and whether loose or stitched or otherwise secured together, are provided with a binding strip, either of cloth or paper, applied to their back or binding edge.

The machine embodying the invention is more especially designed for the manufacture of sketching and writing tablets or pads, but it may be employed in the manufacture of a great variety of books as well as such tablets or pads. The collection of sheets which is operated upon will therefore be herein termed, for convenience, a book, and this term is to be understood as including pads and tablets as well as books proper.

In order to aid in a more easy understanding of the detailed description of the invention which will be hereinafter given, a brief description of the organization and operation of the machine will be first given.

The binding strip of paper or cloth is led from a roll and is subjected to the operation of a pasting mechanism by which it is coated upon one side with a suitable paste or glue. After being thus prepared it is led forward over a table, upon which it is supported with the side which has received the paste uppermost. The books which are to receive the binding strip are placed by an attendant upon a rack, which at proper intervals is vibrated so as to deposit the books, which are placed upon it one at a time, upon the binding strip in such position that they stand vertically with their lower edges resting on the strip. After being thus placed upon the strip the successive books are advanced into the control of a series of vertical feeding rolls by which they are conveyed forward through the machine. The feeding of the strip is accomplished by means of its adhesion to the books

which are acted upon by the feeding rolls and each successive book is advanced into the control of the feeding rolls by means of the strip, which in turn is advanced by means of the preceding book or books which are being acted upon by the feeding rolls. While the strip carrying the book is being advanced, its laterally projecting edges are acted upon by folding guides which turn upward the edges against the sides of the book, and the edges of the strip thus turned upward are pressed against the sides of the book and caused to adhere thereto by means of suitable pressing rolls. The mechanism is so timed that the rack by which the books are introduced into the machine is vibrated to deposit the books so that they will follow each other in close succession, the advance end of one book being in close proximity to the rear end of the preceding one upon the strip.

In order to capacitate the machine to operate upon books of different lengths the mechanism for vibrating the rack to deposit the books upon the strip is controlled by a tripping mechanism which is operated by the successive books placed upon the strip in such manner that the rack will not be vibrated to deposit a second book upon the strip until the rear end of the first one has been advanced to a point beyond the forward end of the next one to be deposited. By this means, as will readily be seen, books of varying lengths can be operated upon and be deposited upon the strip in proper order so as not to interfere with each other. The successive books receiving the binding strip are connected together by said strip and it is therefore necessary to provide mechanism for severing the strip between each two books so as to disconnect them. This is accomplished by a pair of reciprocating knives which are operated at proper intervals for this purpose, the knives being controlled in their operation by a tripping mechanism which is operated by the books in such manner that the knives are brought into action only when the strip and the books attached thereto have arrived in proper position. By this means the operation of the knives is made to conform to the lengths of the books upon the strip.

It is of course necessary that the feeding of the strip and the books should be tempo-

rarily interrupted during the severing operation and for this purpose the tripping mechanism which operates the severing knives is also arranged to arrest the feeding rolls during the severing operation and put said rolls in operation again after the severing operation is completed.

The details in the construction, organization and operation of the mechanism thus briefly outlined will now be given, reference being had to the accompanying drawings, in which—

Figure 1 is a side elevation of one end of the machine, showing particularly the pasting mechanism. Fig. 2 is a similar view partly in section of the other end of the machine. Fig. 3 is a plan view of the portion of the machine shown in Fig. 2. Fig. 4 is an enlarged inverted plan view of a portion of the machine, showing particularly the mechanism for operating the feeding rolls and the mechanism for vibrating the rack to deposit the books upon the strip. Fig. 5 is a similar view of another part of the machine, showing particularly the mechanism for operating the severing blades and putting the feeding rolls into and out of operation. Fig. 6 is a vertical section taken on the line 6 of Fig. 4. Fig. 7 is a vertical section taken on the line 7 of Fig. 6. Fig. 8 is a vertical section taken on the line 8 of Fig. 4. Fig. 9 is a horizontal section taken on the line 9 of Fig. 8. Fig. 10 is an enlarged inside view of the tripping finger which controls the vibration of the rack for introducing the book into the machine. Fig. 11 is a plan view of the same partly in section. Fig. 12 is an enlarged vertical cross section taken on the line 12 of Fig. 2. Fig. 13 is an enlarged detail view showing the mechanism for vibrating the book rack. Fig. 14 is a section taken on the line 14 of Fig. 2. Fig. 15 is an enlarged view of a portion of Fig. 4. Fig. 16 is a section taken on the line 16 of Fig. 15. Fig. 17 is an enlarged side elevation of the pasting mechanism looking from the side opposite that shown in Fig. 1. Fig. 18 is an end elevation of the same looking from the right of Fig. 17. Fig. 19 is a vertical section of one of the paste vats. Fig. 20 is a vertical section taken on the line 20 of Fig. 5. Fig. 21 is a horizontal section taken on the line 21 of Fig. 20, looking upward. Fig. 22 is a similar view showing the same parts in a different position. Fig. 23 is a section taken on the line 23 of Fig. 5. Fig. 24 is a section taken on the line 24 of Fig. 20. Fig. 25 is a section taken on the line 25 of Fig. 9. Fig. 26 is a section taken on the line 26 of Fig. 20. Fig. 27 is a section taken on the line 27 of Fig. 9. Fig. 28 is a perspective view of a book with a binding strip applied by the machine herein shown. Figs. 29 to 32 are detail views which will be hereinafter referred to.

Referring now particularly to Figs. 1, 17, 18 and 19, the mechanism for applying adhesive material to the binding strip will be described. While I prefer to use some preparation of

glue, the term pasting has been commonly applied to mechanism of this class, and I shall use the term paste herein to cover any adhesive material suitable to secure the binding strips, it being understood that the apparatus is especially for use with glue, although the novel features are of value in connection with other adhesive materials.

The strip A of a suitable width, which will be determined by the thickness of the books to which it is to be applied, is led from a roll B. After passing over a guide roll C it passes for a distance in contact with a pasting roll D, thence around a second guide roll E, after which it is led around guide rolls F, G and thence forward above the table H with its pasted side uppermost. In passing the roll C the strip is subjected to the action of a spring presser finger *a*, by which it is pressed against the roll so as to put it under the proper degree of tension. The paste is supplied from a fountain roll I which runs in frictional contact with the roll D and dips in a fountain K. The fountain K is supplied with paste from a similar fountain L, the two being connected by a pipe *b* which is controlled by a valve *c* operated by a float *d* which rides upon the surface of the paste in the fountain K in such manner as to allow the paste to rise in the fountain K to only the proper height with relation to the roll I.

Both of the fountains K, L are steam-jacketed, as indicated in Fig. 19, and communicate with pipes *f* through which steam is admitted to the jackets to keep the paste in the proper condition. The jackets, therefore, will be filled with water from the condensed steam and an overflow is provided so that a constant circulation is maintained, the water being kept hot by the steam. It is important that the paste shall be kept at a uniform temperature, and to prevent it cooling while passing through the pipe *b*, the latter is jacketed also by a sleeve *b'*, surrounding the pipe and communicating with the steam jackets of fountains K, L, as shown in Figs. 1 and 18.

The fountain roll I is preferably formed as shown in Fig. 31, its sides being curved inward from the periphery to form recesses *v*, and the hub being enlarged to form collars *w*. By this construction the use of a doctor or scraper is avoided, as the surplus glue runs down over the edge of the roll into the recesses *v* and thence back into the fountain, the collars *w* preventing its reaching the bearings of the roll.

The necessary rotary movement is imparted to the rolls D, I by the friction of the binding strip A passing over the roll D, from which motion is communicated to the roll I by the frictional contact of the two rolls and by frictional contact with a pair of pulleys *g* mounted upon the shafts of the respective rolls, so that whenever the feed of the strip ceases because of the stoppage of the machine, or otherwise, the rolls D, I remain at rest. It is important that when the machine is in use these rolls

should not be allowed to remain at rest for any considerable length of time because that would permit the paste to dry upon the rolls and thus interfere with the proper application of the paste when the rolls were again started and also cause the strip to adhere to the roll D. To obviate this the pasting mechanism is provided with means by which whenever the machine is temporarily stopped the strip may be removed out of contact with the roll D and the rolls D, I continued in motion, thereby continually receiving a fresh supply of warm paste, which will be prevented from hardening upon their surfaces. For this purpose the pasting apparatus is provided with a short shaft *h* which is driven by a belt *i* which connects with any suitable source of power and is provided with a friction pulley *k* which is in position to be engaged by a similar pulley *l* mounted upon a crank formed upon the end of the shaft *m* of the roll E. When the pulley *l* engages with the pulley *k* it also engages with the pulley *g* upon the shaft of the roll D. The shaft *m* is mounted to oscillate in suitable bearings *o* and carries a pair of arms *p* which are connected to a frame *q* in which is mounted the roll C and the friction device *a*. The frame *q* is provided at its lower end with a cross bar *r* the ends of which rest against standards *p* and retain the frame in such position as to maintain the proper relation between the rolls C, D. The shaft *m* is also provided with a weighted arm *n* which when in its normal position maintains the pulley *l* out of engagement with the pulleys *k*, *g* and the roll C in position to direct the binding strip against the periphery of the roll D as shown by full lines in Figs. 1 and 17. When, however, it is desired to cause the rolls D, I, to continue their movement when the machine is stopped, the weighted arm *n* is swung over to the opposite side of its shaft, thereby swinging the pulley *l* into frictional contact with the pulleys *k*, *g* so as to continue the rolls D, I in motion and at the same time swinging the roll C away from the roll D so as to carry the strip out of contact with the roll D as indicated by dotted lines in Fig. 17.

For the purpose of adjusting the amount of paste applied to the strip, so as to secure the best operation of the machine, I provide means for adjusting the distance between the axes of the paste and fountain rolls, so that the amount of paste may be varied as desired, closer contact of the surfaces giving a thinner coating of paste to the paste roll and vice versa. Either roll may be adjusted for this purpose, and any suitable adjusting means used. I have shown a simple construction, in which the paste roll D is mounted in movable bearings *t* which are slotted and secured to the arms *s* by bolts passing through the slots, accurate adjustment being made by set screws *u*.

The strip A after having been coated upon one side with paste, as has been explained, is led forward above the table H with its pasted

side uppermost until its forward end is at or near the first pair of vertical feeding rolls 50. Located above the table H and just in the rear of the rolls 50 is the vibrating rack M (see Figs. 2, 3, 12 and 14) upon which the books N are placed in an inclined position, as indicated by dotted lines in Fig. 12, and by which they are transferred at the proper times to the vertical position indicated by full lines in said figure with their lower edges resting upon the strip A. The books as they are placed upon the rack M are supported at their lower edges by means of stops 2 (see Figs. 3, 12 and 14) their forward ends abutting against a stop 3 (see Fig. 3) which determines the proper position of the forward end of each book as it is placed upon the strip to conform to the rear end of the preceding book. The stops 2 are secured to the lower side of the rack M so as to be capable of longitudinal movement thereon and each stop is provided upon its side with a stud 4 which enters the cam groove 5 in a plate or bracket bolted to the frame, which groove is eccentric to the shaft upon which the rack vibrates so that when the rack is lowered to the inclined position shown in Figs. 12 and 14 the stops will protrude above the surface of the rack, as indicated, while, when the rack is raised to its vertical position to deposit the book upon the strip the studs 4 moving in the eccentric grooves 5 will draw the stops inward and the book will then be permitted to slide freely off the rack onto the strip.

The table H is provided upon the side of the strip opposite the rack M with a number of brackets O which serve to support the books in their vertical position as they are discharged from the rack. The brackets O are provided with pivoted hooks 49 which catch over the top edges of the books as they are deposited upon the strip and support them in their vertical position until they have entered between the first pair of feed rolls 50. To insure the catching of the books, the hooks are preferably made of two parts to form a double hook. The hooks forming the double hook may be side by side, but I prefer the construction shown in Figs. 8, 12 and 32, in which one is pivoted to swing in a slot in the other, the inner hook 49^a extending slightly beyond and below the outer so as to seize the book in advance of the latter. A spring *x* presses both hooks downward, the hook 49^a being first actuated by the spring in seizing the book, as it is raised above the outer hook 49. The hooks are preferably made vertically adjustable, as indicated in Fig. 12 so as to accommodate themselves to books of different widths. The table H is also provided with one or more adjustable curved guides 48 which are arranged to act upon the lower edges of the books to guide them accurately to the center of the strip as they are delivered by the rack.

The rack M is, as before stated, automatically operated to deposit each book upon the

strip with its forward end in proper relation to the rear end of the preceding book, and in order to permit the machine to operate upon books of varying lengths the movements of the rack are controlled by a tripping mechanism which is controlled by the last book deposited upon the strip in such manner that the next book will not be deposited until the rear end of the last book deposited has arrived at a certain position. For this purpose the shaft 51 upon which the rack M is supported, is provided with an arm 52 (see Fig. 13) which is connected by a rod 53 with the end of a lever 54 which is fulcrumed beneath the table H as indicated at 55 (see Figs. 4, 6 and 7) and is provided with a stud or bowl 47 which travels in the groove of a cam 56 mounted loosely upon a shaft 57 which is constantly driven through a sprocket wheel and chain 58, 59, (see Figs. 2, 4 and 5) from the main driving shaft 60 which receives motion through a pulley 61 from any suitable source of power. The shaft 57 is provided with a disk 62 (see Figs. 4 and 7) which is keyed fast to the shaft and is provided with flanges 46 which overlap the hub of a gear 63 which is loose upon the shaft 57. Interposed between the flanges 46 and the hub of the gear 63 are wear pieces 45 which are acted upon by set screws passing through the flanges so as to be pressed against the hub of the gear 63 with a determined amount of pressure, thereby causing the disk 62 to drive the gear 63 through an adjustable frictional connection. The gear 63 engages with a gear 64 (see Fig. 4) mounted upon a countershaft 65 and having a second gear 66 which engages with a gear 67 secured to the side of the cam 56.

It will be seen that by reason of the connections which have been described a force is constantly exerted tending to drive the cam 56 and that this force is equal to the friction of the wear pieces 45 against the hub of the gear 63. The force thus applied to the cam 56 is sufficient to drive said cam and cause it to rock the lever 54 and vibrate the book rack M when no extra resistance is offered to the movement of the cam. The groove of the cam 56 is so formed (see Fig. 6) as to vibrate the lever 54 and rack M four times at each revolution of the cam, and the cam is provided around its periphery with four studs 44 which are in position to be engaged by a spring-pressed hook 43. The resistance of the hook 43 is so graduated by means of its spring 42 that it is sufficient to overcome the friction between the disk 62 and the gear 63 and thus arrest and hold the cam 56 until such time as extra force is applied to overcome the resistance of the hook. For the purpose of applying this extra power to the cam 56 to cause it to overcome the resistance of the hook 43 at the proper times to operate the rack M to deposit the books upon the strip, there is located upon the table H a tripping lever 68 (see s. 6, 8, 9, 10 and 11) which is fulcrumed

at 69 with its rear end extending slightly to the rear of the stop 3. This tripping lever is so positioned that its rear end is just at one side of the lower edge of the books as they are advanced by the strip after being deposited thereon. Pivoted upon the rear portion of the tripping lever 68 is a supplemental lever 41 having a head 40 which projects slightly beyond the end of the lever 68. Also pivoted upon the lever 68 at the side of the supplemental lever 41 is a tripping dog 39 one end of which engages with a shoulder 6 formed upon the lever 41 in such manner as to lock and hold the lever 41 with its head 40 projecting slightly beyond the inner side of the lever 68 and in position to bear against the lower edge of the book as it is advanced by the binding strip. The dog 39 is also provided with a head 7 which projects beyond the inner side of the lever 68 and with a stud 8 which bears against the inner side of the lever 41. The dog 39 is acted upon by a spring 38 in such manner that it is normally held in position to lock the lever 41 and also to cause its own head 7 to project beyond the inner side of the lever 68. Between the head 40 and the fulcrum 69 of the lever 68 the lever is connected to a stud 70 (see Figs. 4, 8, and 15) which passes through a slot in the table and is connected to the end of a lever 71 which is fulcrumed beneath the table as indicated at 72 and is acted upon by a spring 73 the tendency of which is to rock the lever 71 and through the stud 70 also rock the tripping lever 68 so as to press the head 40 of the supplemental lever 41 against the lower edges of the sides of the books as they pass forward upon the binding strip, the head 40 thus forming a presser-foot engaging the sides of the book until the latter has passed it. As the result of this organization it will readily be seen that as each book passes forward upon the binding strip and as long as it is present opposite the head 40 of the supplemental lever 41, said lever being locked in position by the dog 39, it will prevent the lever 71 and through it the lever 68 from being moved inward by the pressure of the spring 73. As soon, however, as the rear end of a book passes the head 40 the pressure of the spring 73 will not be resisted by the levers 41, 68 and as a consequence the spring will operate to rock the lever 71 and also rock the lever 68 inward slightly. As the rear end of the book passes the head 40 and the lever 68 is rocked inward the head 7 of the dog 39 will be pressed against the side of the book so as to rock the dog away from the shoulder 6 and through the stud 8 rock the lever 41 so as to carry its head 40 out of position to be engaged by the forward end of the next book which is advanced by the strip.

The lever 71 is provided at its end opposite to the connection with the stud 70 with a fork 37 (see Figs. 4, 7 and 8) which is connected to a loose band which runs in a groove formed upon the movable member 74 of a

clutch, the opposite member of which is formed upon or connected to the gear 67. The member 74 of the clutch is splined to the shaft 57 so as to be capable of moving freely lengthwise of the shaft without turning loosely upon the shaft. The end of the lever 71 opposite the fork 37 is connected to a rod 75 (see Figs. 4, 15 and 16) having a recess, into which enters the arm of a latch 36 which is pivoted upon the under side of the table H and engages with a stud 9 projecting from a collar 35 formed upon a bolt 76 which abuts against the lever 71 and is provided with a powerful spring 34 the tendency of which is to press said bolt 76 and rock the lever 71 so as to cause the two members of the clutch upon the shaft 57 to engage and thus lock the cam 56 to the shaft. The latch 36 is provided with a spring 33 the tendency of which is to rock and hold the latch in such position as to cause it to engage with the stud 9 and hold the bolt 76 in position to prevent it from acting to rock the lever 71.

Fulcrumed upon a stud projecting downward from the table H (see Figs. 4, 6 and 15) is a horizontal vibrating lever 77 the forward end of which enters a recess formed in the collar 35 of the bolt 76 in such manner that when the lever is rocked in one direction the collar and bolt will be moved away from the lever 71 so as to compress the spring 34 and permit the latch 36 to engage with the stud 9 so as to hold the spring 34 in its compressed condition. The opposite end of the lever 77 is provided with an inclined cam surface 32 which is arranged to be engaged by the studs 44 upon the periphery of the cam 56 in such manner as to rock the lever 77 and compress the spring 34, as before stated. The lever is acted upon by a spring 78 the tendency of which is to rock the lever in the opposite direction. The cam 56 is provided upon its face with four cam projections 81 (see Figs. 4, 6 and 7) corresponding in position to the studs 44 which are arranged, as the cam is revolved, to act upon the lateral projection 82 extending from the lever 71 in such manner as to rock the lever and unclutch the cam 56 from the shaft 57. Located also beneath the table is a hand-lever 79 (see Figs. 4, 6, 8 and 29) which is fulcrumed as indicated at 80 and is provided at its inner end with a shoulder which is adapted to engage with a stud 31 projecting from the side of the stud 70 in such manner as to hold said stud 70 and the lever 71 permanently in position to prevent the clutching of the cam 56 to the shaft 57.

The operation of the mechanism which has been described for controlling the movements of the rack M is as follows:—The binding strip A properly coated with paste will be advanced above the table H until its forward end is at or near the first pair of the vertical feeding rolls 50. A book N having been placed upon the rack as indicated by dotted lines in Fig. 12 and the machine having been started the

lever 79 will be operated so as to permit the spring 73 to rock the lever 71. There being no book present to arrest the movement of the tripping lever 68 the spring 73 will at once rock the lever 71 as before described. As the lever 71 is thus rocked the rod 75 will be moved and will engage with the latch 36 so as to rock the same and release the stud 9. This will permit the spring 34 to expand and force the bolt 76 against the lever 71 so as to rock said lever and carry the movable member 74 of the clutch into engagement with the fixed member carried by the gear 67, thereby clutching the cam 56 to the shaft 57. As soon as the cam is thus clutched to the shaft the stud 44 will be forced past the spring hook 43 and the cam will revolve with the shaft. As the cam revolves it will through the bowl 47 operate the lever 54 and through the connections which have been described vibrate the rack so as to deposit the book carried by the rack upon the strip as indicated by full lines in Fig. 12, after which the rack will be vibrated back to its normal position. In making these movements the cam 56 will have made about a quarter of a revolution. As the cam nears the completion of its quarter revolution one of the studs 44 will engage with the incline 32 of the lever 77 and rock said lever so as to compress the spring 34 and withdraw the bolt 76 away from the lever 71 and at the same time one of the cam projections 81 upon the side of the cam 56 will engage with the lateral projection 82 of the lever 71 and rock said lever back to its normal position so as to unclutch the cam 56 from the shaft 57 and at the same time through the rod 75 rock the latch 36 into position to engage the stud 9 and hold the bolt 76 away from the lever 71. As soon as this takes place the cam 56 will of course cease to be driven directly from the shaft 57 but the friction between the disk 62 and gear 63 will be sufficient, as before explained, to continue the movement of the cam until one of the studs 44 engages with the spring hook 43, when the cam will be arrested. This additional movement of the cam 56 will, however, carry the stud 44 past the incline 32 of the lever 77 and the cam projection 81 past the projection 82 of the lever 71 so that said levers will be free to operate when the time arrives for the next clutching operation. As the lever 71 is rocked to unclutch the cam 56 from the shaft 57, as just explained, it will through the stud 70 rock the tripping lever 68 outward to its normal position where it will be held by the book which has just been placed upon the strip so as to prevent the lever 71 from being rocked inward by the spring 73, so as to rock the latch 36 and release the spring 34. After the first book has been placed upon the strip in the manner just described it will by reason of the paste upon the strip adhere thereto so that upon being advanced it will carry the strip with it and as a result advance any subsequent books placed upon the strip. It will

be necessary, however, after the first book has been placed upon the strip to advance it by hand until its forward end is entered into the bite of the first pair of feeding rolls 50. This being done the rolls will advance the book and with it the strip and the subsequent books without further hand manipulation. As the book is advanced by the feeding rolls the head 40 of the supplemental lever 41 which is pivoted upon the tripping lever 68 will bear against the lower edge of the book and prevent the tripping lever from being swung inward and thus hold the lever 71 in its normal position, and this will continue until the rear end of the book has passed the head 40. From this it will be seen that the successive vibrations of the book rack are determined by the presence or absence of a book in front of the head 40 and that the rack will not be vibrated to deposit a second book upon the strip until the rear end of the preceding book has passed said head 40. By this means the vibrations of the rack are timed to conform to the length of the books operated upon so that longer or shorter books can be operated upon at pleasure, the vibrations of the rack being caused to conform to the lengths of the books so as to deposit them in proper relation to each other upon the strip. As the rear end of the book passes the head 40 the lever 68 will yield to the tension of the spring 73 as before explained so as to permit the spring to rock the lever 71 and cause the clutching of the cam 56 to the shaft 57 as before described so as to operate the rack and deposit a second book, which in the meantime has been placed thereon, upon the strip; and so the operation will be repeated as the rear end of each book passes the head 40.

It will be seen from the construction and organization of the clutching and tripping mechanism which has been described that if at any time it happens that no book is present upon the binding strip to hold the tripping lever 68 when the lever 71 is operated to unclutch the cam 56 from the shaft 57 the spring 73 will immediately act to trip the latch 36 and re clutch the cam to the shaft and vibrate the book rack, and this clutching and unclutching will take place in rapid succession, thereby vibrating the book rack rapidly to the injury of the machine as long as no book is present to arrest the tripping lever 68. If the attendant whose duty it is to place the books upon the rack is skillful and attentive, this contingency will not arise because the attendant will always have a book upon the rack to be deposited upon the strip at each vibration of the rack, but if through carelessness or tardiness on the part of the attendant or through the failure of the rack to properly deposit the book so as to be in position to control the tripping lever 68 it should happen that no book was present to control the tripping lever at the time the unclutching of the cam 56 takes place, it is desirable

to have the machine provided with means by which the violent operation of the book rack before referred to will be obviated. To accomplish this the shaft 57 in addition to the parts already specified is provided with a loose disk 83 which is frictionally connected to the shaft by means of a disk 84 which is fast upon the shaft and is provided with flanges 30 (see Fig. 4) which overlap a portion of the disk 83 and are provided with friction pieces similar to the friction pieces 45 which bear upon the disk 83 with a degree of pressure which can readily be regulated by means of set screws, as shown. The disk 83 is also connected to the hub of the cam 56 by means of a pin 29 (see Figs. 6 and 7) which enters a slot 28 formed in said hub and so arranged that when the cam 56 is clutched to the shaft 57 the cam will revolve a distance equal to the length of the slot 28 before communicating its motion to the disk 83. The disk 83 is provided around its edge with four recesses 27 (see Figs. 4 and 6) arranged at equal distances from each other and in a certain relation to the cam 56. Pivoted upon a bracket beneath the table II is a lever 85 the rear end of which extends above the disk 83 and is provided with a lug 26 of suitable form to enter one of the recesses 27 when it is permitted to do so. The forward end of the lever 85 terminates beneath a vertically-sliding block 86 (see Figs. 6 and 16) having a transverse opening through which passes a horizontally-sliding block 87 which is connected by a rod 88 with the end of the lever 71 in such manner that when said lever 71 is rocked as before explained the block 87 will be caused to move horizontally through the opening in the block 86. The lever 85 is provided with a spring 25 the tendency of which is to rock the lever so as to raise the block 86 whenever the lug 26 enters one of the recesses 27. When the lug 26 is raised out of one of the recesses 27 and rests upon the periphery of the disk the opposite end of the lever 85 is rocked away from the block 86 leaving the block free to descend by gravity. The blocks 86, 87 are provided with oppositely-arranged engaging teeth 10 (see Fig. 16) which are so arranged that when the block 86 is in its lowermost position and the lever 71 is in its normal position the teeth will engage and hold the lever 71 in that position. The operation of this part of the apparatus is as follows:—The shaft 57 being set in motion the disk 83 will be driven through its frictional connection with the disk 84 until one of the notches 27 arrives in position beneath the lug 26 of the lever 85 when the spring 25 will rock the lever so as to cause the lug to enter the recess, and the frictional connection between the disks 83 84 is so adjusted that while it is sufficient to move the disk 83 when the lug 26 is resting upon the periphery of the disk it is not sufficient to overcome the resistance of the lug when the latter enters one of the recesses 27, and as a consequence when the

lug 26 is in that position the disk 83 does not turn with the shaft 57. So long as the lug 26 remains in one of the recesses 27 the lever 85 will be rocked so as to raise the block 86 and throw the teeth 10 out of engagement, thereby permitting the lever 71 to move freely. When the cam 56 is clutched to the shaft 57 as before explained so as to revolve with the shaft it will revolve independently of the disk 83 until the slot 28 is carried to such position that its rear end engages with the pin 29. The length of the slot 28 is such that by the time this takes place the cam 56 will have nearly completed a quarter revolution and the time will nearly have arrived for the unclutching of the cam from the shaft. As soon as the stud 29 engages with the rear end of the slot 28 the movement of the cam 56 will be communicated to the disk 83 and as a result the disk will be set in motion so as to raise the lug 26 out of the recess 27 by the cam action of the rear wall of the recess thereon and rock the lever 85 so as to permit the block 86 to descend by gravity. Immediately after this takes place the unclutching of the cam 56 will take place, thereby rocking the lever 71 to the position shown in Figs. 4, 15 and 16 so as to move the block 87 through the opening in the block 86 and carry the tooth of the block 87 past the tooth of the block 86 as shown in Fig. 16 so that the two will engage and hold the lever 71 temporarily in that position so as to prevent the spring 73 from acting immediately to re clutch the cam to the shaft in case no book is present to hold the tripping lever 68. The block 86 being disconnected from the lever 85 will readily rise to allow the teeth 10 to pass each other. As soon as the unclutching of the cam 56 takes place the disk 83 will of course cease to be driven by the cam, but the lug 26 having been raised out of the recess 27 the frictional connection between the disks 83, 84 will be sufficient to drive the disk 83 until the next recess 27 arrives beneath the lug 26 when the lug will drop into the recess and thereby arrest the disk 83 and at the same time rock the lever 85 so as to raise the block 86 into position to release the block 87 and permit the lever 71 to be operated. This interval, however, will be sufficient to allow the attendant to see that the book is in proper position or to allow the book if placed upon the rack too far to the rearward to be advanced by the binding strip into position to hold the tripping lever 68; or if the attendant fails entirely to place any book upon the rack the intervals between the unclutching and clutching effected by means of the mechanism which has just been described will be sufficient to prevent the book rack from being operated violently. The book having been advanced into the control of the first pair of feeding rolls 50 is then advanced by said rolls into the control of a second pair of feeding rolls 89, and then by the rolls 50, 89 it is advanced into the control of a third pair of feeding rolls

90, by which it is finally delivered from the machine. The rolls 50, 89, 90 are arranged vertically and are preferably composed of pulleys or disks which are adjustable upon their vertical shafts so as to bear upon the book at the proper height and be made to conform to books of different widths. The disks are shown as arranged at the same height, but it will frequently be found desirable to make the different feeding rolls engage the book on different lines, and my construction of feeding rolls composed of independent adjustable disks enables me to do this.

For the purpose of holding the books snugly down onto the binding strip there are provided one or more rolls 91 which bear upon the top edge of the book as it is passed between the vertical feeding rolls. The rolls 91 are vertically adjustable in brackets 92 in which they are supported and conform to books of different widths. The brackets 92 are provided with plates next the book rack, which are curved outward to form guides cooperating with similar guides γ carried by the bearing of roll 91 on the opposite side of the book to guide the latter and hold the leaves in place as the book is advanced.

The feeding rolls 50, 89, 90 are positively driven in the following manner: The shafts of the rolls 90 are provided with pulleys 24 which are connected by belts 93 with pulleys 94 which are rigidly secured together and are mounted loosely upon the main driving shaft 60 but are provided with a clutch mechanism which will be hereinafter explained by which they can be clutched to said shaft. The rolls 89 are driven from the rolls 90 by means of sprocket chains 95 which pass around sprocket wheels upon the lower ends of the shafts of said rolls. The rolls 50 are driven from the rolls 89 by means of sprocket chains 96 which pass around pulleys upon the upper ends of the shafts of said rolls. Located just in advance of the rolls 50 are a pair of curved folding guides 23 (see Figs. 8, and 9) which are arranged to act upon the edges of the binding strip which project beyond the sides of the book and fold them upward and press them against the sides of the book as the book and strip are advanced by the feeding rolls as shown in Fig. 28. Located just beyond the folding guides 23 are a pair of inclined pressing and smoothing rolls 97 which revolve in the opposite direction from the feeding rolls and act to press and smooth the edges of the binding strip against the sides of the book after they have been turned upward by the curved folding guides. The pressing rolls 97 are positively driven by means of belts 98 which pass around pulleys 99 which are made integral with or secured to the pulleys 94. The belts 98 pass over suitable guide pulleys 100 and around pulleys 101 upon the lower ends of the shafts of the rolls. The brackets 102 in which the vertical feeding rolls 50, 89, 90 are supported are

made adjustable upon the table H so as to adapt the rolls to accommodate books of different thicknesses. For this purpose the brackets are provided at their lower ends with extensions which pass through slots in the table and are bolted to plates 103 located beneath the table and provided with bearings for the lower ends of the shafts of the rolls 89, 90. One of the plates 103 beneath the table also supports the brackets 104 for the shafts of the rolls 97. To simultaneously and accurately adjust all of the rolls the plates 103 which are connected to the brackets of the rolls 89, 90 are connected to each other by plates 105 which form nuts for a right and left hand screw shaft 106 which is fixed in bearing 107 secured to the under side of the table and is provided with a gear which engages with a gear 108 upon a shaft 109 having a second gear 110 which engages with a gear upon a right and left hand threaded shaft 111 which passes through nuts formed in the plates 103 which are connected to the brackets of the rolls 50. The shaft 111 is provided with a handle 112 by which it can be conveniently operated so as to simultaneously adjust all the rolls to conform to books of different thicknesses.

Adjustments are provided for all the feeding rolls 50, 89, 90 and 97, by which their positions are varied for books of different sizes, but it is found that books, and especially writing pads, of the same lot are not uniform, but vary slightly in thickness and width. To secure uniform action without clogging, therefore, it is desirable that the rolls should adjust themselves to such variations. For this purpose the shafts of the rolls are mounted in spring bearings, which may be of any suitable form. As shown in Figs. 2 and 8 the first top roll 91 is carried in bearings sliding on adjustable rod 153 and spring pressed by springs 154, while the other top rolls are mounted in bearings supported in elliptic springs 155. The bearings of the side rolls 50, 89, 90 and 97 are of the form shown in Fig. 30 in connection with rolls 90, the bearings being formed in two parts pressed together by springs 156, the pressure being adjusted by set screw 157. It may not be absolutely essential that the spring bearings be applied to the rolls on both sides of the book, but this feature is important, as the yield is thus equal on opposite sides and the book is held in central position so as to coact properly with the other parts.

It has now been explained how the books are placed successively upon the binding strip and the edges of the strip turned up and pressed against the sides of the books so as to adhere thereto. When this is accomplished the books are, as will readily be seen, connected by the strip, and it is desirable therefore that before the books leave the machine the binding strip should be severed between each two books so as to detach the books from each other. For this purpose the table H is

provided between the feeding rolls 89, 90 with a pair of reciprocating knives 113 (see Figs. 3, 6, 9 and 25) the adjacent edges of which are moved to and from each other at proper intervals to sever the binding strip between each two books. For the purpose of imparting the necessary reciprocating movement to the knives they are provided with oppositely arranged racks 114 which are engaged by a gear 115 located between them in such manner that as the gear is turned in one direction the knives are caused to approach each other and as it is turned in the opposite direction they are caused to recede from each other. The gear 115 is operated by means of an arm 116 which is connected to the shaft of the gear and to a rod 117 which in turn is connected to a lever 118 (see Figs. 2, 5, 20 and 26) which is fulcrumed beneath the table as indicated at 119 and is acted upon at its opposite end by a cam 120 which is mounted loosely upon the main driving shaft 60 but is arranged to be clutched to the shaft at the proper times to operate the knives to sever the binding strip between each two books. A single movable knife may be used, and the knife or knives be of any other suitable form or movement.

It has already been explained how the books deposited upon the binding strip may vary in length and as the movement of the feeding rolls is uniform it follows that the knives 113 must be operated at varying intervals, determined by the length of the books upon which the machine is operating. To accomplish this there is located upon the top of the table an arm 121 (see Figs. 9 and 27) the free end 22 of which forms a presser foot bearing against the sides of the books at a point just in advance of the knives 113. The opposite end of the arm 121 is fulcrumed to a vertical stud 122 (see Figs. 20, 21, 22 and 24) which passes through the table and is connected to a lever 123 which is acted upon by a spring 124 the tendency of which is to rock and hold the presser foot 22 in contact with the sides of the books. The free end of the tripping lever is provided with a lip 21 which engages with a pivoted dog 20 having a hook which normally engages with a shoulder upon a second dog 19 having a second shoulder which engages with a corresponding shoulder upon a third dog 18 the end of which is normally in position to engage with a stud 17 projecting from the end of a bell crank lever 125 having a stud 16 which is in position to engage with a clutch lever 126 which is fulcrumed as indicated at 127 and the free forked end of which enters a groove formed in a collar 128 (see Figs. 5 and 26) which is splined to the main driving shaft 60 but is arranged to slide longitudinally of said shaft. So long as a book is present and in engagement with the presser-foot 22 on the arm 121 the lever 123 will be held in the position shown in Fig. 22, thereby permitting the spring 15 of the dog 20 to rock said dog into position to engage with the shoulder upon the

dog 19 to hold the dog 19 also in the position shown in said figure and also permitting the spring 14 to rock the dog 18 into position to engage with the stud of the lever 125. The dog 19 is provided with a spring 13 the tendency of which, as soon as the dog 20 is rocked to release the dog 19, is to rock the latter dog and through it rock the dog 18 out of the path of the stud 17 thereby permitting the spring 129 with which the lever 125 is provided to rock said lever so as to cause the stud 16 to engage with the lever 126 and shift the sleeve 128. The sleeve 128 is provided upon its opposite ends with members of two clutches which engage respectively with corresponding members of clutches formed upon the pulleys 94, 99 and the cam 120 so that when the sleeve is in its normal position it will engage with the pulleys 94, 99 so as to clutch them to shaft 60 and operate the feeding rolls, while when the sleeve is shifted to its other position by the engagement of the stud 16 with the lever 126 it will unclutch the pulleys 94, 99 from the shaft thereby stopping the feeding and at the same time clutch the cam 120 to the shaft so as to operate the knives to sever the binding strip.

The end of the lever 125 is connected to the lever 126 by means of a hoop-like spring 130 which is attached to the respective levers by means of studs 11 12. This spring is so adjusted that as the lever 125 is rocked to carry the stud 16 against the lever 126 the spring will be slightly compressed before the stud comes in contact with the lever and that as the lever 125 is rocked in the opposite direction the spring will be slightly expanded before its tension is sufficient to move the lever 126.

Rigidly connected to the cam 120 is a second cam 131 which engages with the forward end of a lever 132, the rear end of which is provided with two inclined studs 133, 134 the former of which as the lever is rocked by the cam 131 enters an opening 135 in the end of the lever 123 and acts to restore said lever to its normal position and through it rock the arm 121 so as to move the end 22 of said arm outward and the latter of which rides upon the inclined end of the dog 19 to rock said dog into position to be engaged and held by the dog 20.

The operation of the mechanism for severing the binding strip as thus far described is as follows:—As each book passes from the feeding rolls 89 to the feeding rolls 90 the presser-foot 22 on the arm 121 will be pressed inward against the side of the book at its lower edge by the action of the spring 124. The presence of the book will, however, prevent the arm 121 from being rocked inward and as a consequence the lever 123 will remain in the position shown in Fig. 22 and this will continue for an indefinite time, depending upon the length of the book. As soon as the rear end of the book passes the presser-foot 22 there will be nothing to resist the ten-

sion of the spring 124 and said spring will therefore rock the arm 121 inward and also rock the lever 123 to the position shown in Fig. 21. This will rock the dog 20 so as to release the dog 19 and permit its spring 13 to rock it to the position shown in Fig. 21 thereby rocking the dog 18 so as to release the stud 17 and permit the spring 129 to rock the lever 125 and compress the spring 130 slightly and bring the stud 16 into engagement with the lever 126 thereby rocking said lever 126 so as to unclutch the pulleys 94, 99 from the shaft 60 and stop the feeding rolls and at the same time clutch the cams 120, 131 to the shaft 60. As soon as this takes place the cam 120 will operate the lever 118 and through the connections which have been described move the knives inward so as to sever the binding strip just in the rear of the book which has passed the end 22 of the arm 121 and just in front of the next succeeding book. As the lever 118 is thus rocked it will through the rod 136 and arm 137 rock the shaft 138 and lever 125 so as to move the stud 16 away from the lever 126 and put the spring 130 under tension and this will continue until the knives have reached or just about reached their extreme inward position when the tension of the spring 130 will become sufficient to rock the lever 126 and unclutch the cams 120, 131 from the shaft 60 and at the same time re clutch the pulleys 94 99 to the shaft to start the feeding rolls. Previous to this, however, and while the knives are being moved inward by the cam 120 the cam 131 will rock the lever 132 so as to cause the stud 133 to enter the recess 135 and rock the lever 123 back to the position shown in Fig. 22, thereby rocking the arm 121 so as to carry its rear end 22 out from behind the book which has been severed from the strip and from within the path of the incoming one, and at the same time the stud 134 acting upon the end of the dog 19 will rock said dog to the position also shown in said figure. The lever 132 will remain in this position until at or just about the time the unclutching of the cams takes place as before explained. At this time the inclined end 139 of the lever 132 will arrive in position to pass over one of the abrupt shoulders of the cam 131 and the spring 140 of the lever will then rock the lever inward so as to withdraw the studs 133 and 134 and release the lever 123 and at the same time impart a slight additional movement to the cams 120, 131 which will permit the end of the lever 118 to drop over the abrupt shoulder of the cam 120 and thereby allow its spring 141 to retract the knives. This movement of the lever 118 will allow the lever 125 to be restored to its normal position where it will be arrested by the engagement of the stud 17 with the dog 18 as shown in Fig. 22.

From the foregoing it will be seen that the lever 123 is released from the stud 133 substantially simultaneously with the retraction of the knives and the starting of the feeding

rolls and it will also be seen, inasmuch as there is a slight space between each two books in the line, that if means were not provided for preventing it the spring 124 would operate immediately upon the release of the lever 123 to swing said lever back to the position shown in Fig. 21 and thus operate the clutches to stop the feed and set the knives in operation. To avoid this the shaft 60 is provided with a third cam 142 which is loose upon the shaft but is connected frictionally thereto by means of a disk 143 which is fast upon the shaft and is provided with flanges 144 which overlap a shoulder upon the cam 142 and act frictionally thereon through friction pieces the same as already described in connection with the gear 63. The disk 142 is provided around its periphery with a number of notches 145 which receive a lug upon the end of a lever 146 which is fulcrumed upon a bracket depending from the under side of the table. The opposite end 147 of the lever is inclined and is in position when rocked by the disk 142 to engage with the lever 123 and retain the same temporarily in the position into which it has been rocked by the lug 133 of the lever 132. The lever 146 is provided with a spring 148 which acts to press the end of the lever against the disk 142 and its lug into one of the notches 145. The friction between the disk 142 and the disk 143 is sufficient to communicate the motion of the shaft 60 to the disk 142 so long as the lug of the lever 146 rests upon the smooth periphery of the disk. As soon, however, as the lug of the lever falls into one of the recesses 145 the resistance thus offered to the disk 142 is sufficient to overcome the frictional connection with the shaft 60 and to release the disk. The disk 142 is connected to the cams 120 131 by means of a stud 149 which projects from the cams and enters a slot 150 formed in the disk 142. The operation of this part of the mechanism is as follows: When the cams 120, 131 are thus clutched to the shaft 60 the pin 149 will move in the recess 50 and no motion will be communicated to the disk 142. Before the unclutching of the cams takes place, however, the pin 149 will arrive at the end of the slot 150 and communicate the motion of the cams to the disk so as to move the disk and cause the lug of the lever 146 to ride up onto the periphery of the disk, thereby rocking the lever so as to carry its inclined end 147 upward into position to act against the lever 123 and hold it in the position into which it has been rocked by the lug 133. Immediately after this the unclutching of the cams will take place and the withdrawal of the lug 133 from the recess 135 will also take place. The lever 123, will, however, be retained in the position it then occupies by the end of the lever 146 and this will continue so long as the lug of the lever 146 rides upon the periphery of the disk 142 which has already been stated; that when the lug of the lever 146 is upon the periphery of the disk the resistance to the

disk will not be sufficient to prevent it from being moved through its frictional connection with the shaft 60. When therefore the cams are unclutched from the shaft the disk 142 will continue to be moved through its frictional connection with the shaft 60 and this will continue until the lug on the end of the lever 146 drops into one of the recesses 145 when the disk will be arrested. This rocking of the lever 146 will, remove its end 147 from the path of the lever 123 but in the meantime while the lever 123 has been held by the lever 146 the feeding rolls have been in motion and have advanced the next book in the rear of the one which has been severed into position in front of the end 22 of the arm 121 so as to hold said arm and prevent the lever 123 from being rocked by the spring 124. If, however, through the inattention of the attendant or for any other cause the space between two books should be so great that a second book is not in position to arrest the arm 121 when the lever 123 has been released as just described, it is desirable that means should be provided for preventing the knives from operating. For this purpose the table is provided opposite the end 22 of the arm 121 with a spring seated presser plate 151 (see Figs. 8, 9, and 27) over which the books pass as they move forward between the feeding rolls. This plate is provided with a lateral extension having a pawl 152 which is arranged to engage with a ratchet upon the under side of the projecting end 22 of the arm 121. The plate 151 is of such length that when the books pass forward in proper sequence the rear end of the preceding book will not have left the plate until the forward end of the next book has arrived upon the plate and so long as a book rests upon the plate it will be depressed so that its pawl will not engage with the ratchet. If, however, the space between two succeeding books is so great for any cause that the rear end of the preceding book has left the plate before the forward end of the succeeding book arrives upon it the plate will spring upward and the pawl 152 will engage with the ratchet so as to hold the arm 121 in its retracted position and prevent it from being swung inward so as to operate the knives, and this will continue until the next book arrives upon the plate when it will be depressed so as to release the arm 121 from the pawl 152.

The machine may be driven in any suitable manner and any suitable means provided for throwing it into and out of operation. I have shown for this purpose fast and loose pulleys on main shaft 60 and a belt shifter carried by a sliding bar 159, as shown in Fig. 3. It is desirable that the arms *p* on the pasting mechanism should be simultaneously rocked to throw the strip out of engagement with paste roll D and throw the driving mechanism of the latter into operation. I secure this by providing a sliding rod 160 secured to a crank arm on rock shaft *m*, as shown in

dotted lines in Fig. 1, this rod extending to the opposite end of the machine and provided with a head through which the sliding bar 159 passes, the latter having cam surfaces 161 which move the rod 160 to rock the shaft *m* and swing the weighted arm *n* to one side or the other of the vertical as the belt is shifted to throw the machine into or out of operation.

It will be understood that my invention is not to be limited to the specific construction of the machine shown and described, as it is evident that many modifications may be made therein by one skilled in the art without departing from my invention.

Having thus described my invention, what I claim as new, and desire to secure by Letters Patent, is—

1. In a machine for applying binding strips to the backs or binding edges of books, the combination with pasting mechanism, of mechanism for automatically depositing, at proper intervals, the closed books edgewise onto a continuous pasted binding strip, and feeding mechanism for advancing the books and attached binding strip through the machine longitudinally of the strip, substantially as set forth.

2. In a machine for applying binding strips to the backs or binding edges of books, the combination with pasting mechanism, of mechanism for automatically depositing the closed books edgewise at proper intervals onto a continuous pasted binding strip, feeding mechanism for advancing the books and attached strip through the machine longitudinally of the strip, and mechanism for automatically severing the strip between the books, substantially as set forth.

3. In a machine for applying binding strips to the backs or binding edges of books, the combination with pasting mechanism, of mechanism for automatically depositing the books at proper intervals onto the pasted binding strip, feeding mechanism for advancing the books and attached strip through the machine, means for folding the edges of the binding strip against the sides of the books and mechanism for severing the binding strip between the books, substantially as set forth.

4. In a machine for applying binding strips to the backs or binding edges of books, the combination with pasting mechanism, of mechanism for depositing at proper intervals the books onto the pasted binding strip, feeding mechanism for advancing the books and attached strip through the machine, means for folding the edges of said strip against the sides of the books, means for smoothing the turned up edges of the strip and mechanism for severing said strip between the books, substantially as set forth.

5. In a machine for applying binding strips to the backs or binding edges of books, the combination of pasting mechanism for the binding strip, mechanism for depositing the books onto the pasted surface of said strip, feeding mechanism co-operating with the

books and attached strip for advancing the books and the strip through the machine, and mechanism controlled by the books passing through the machine to automatically operate said depositing mechanism at proper intervals, substantially as set forth.

6. In a machine for applying binding strips to the backs or binding edges of books, the combination with feeding mechanism for advancing the books through the machine, of a book depositing mechanism for supplying successive books to the feeding mechanism, and means for controlling the book depositing mechanism by the books successively advanced by the feeding mechanism, substantially as set forth.

7. In a machine for applying binding strips to the backs or binding edges of books, the combination with feeding mechanism for advancing the books through the machine, of a book depositing mechanism for supplying successive books to the feeding mechanism, and a tripping mechanism co-operating with the books successively advanced by the feeding mechanism and controlling the book depositing mechanism, substantially as described.

8. In a machine for applying binding strips to the backs or binding edges of books, the combination with feeding mechanism for advancing the books through the machine, of a book depositing mechanism for supplying successive books to the feeding mechanism, and a tripping mechanism controlling the book depositing mechanism and co-operating with the books successively advanced by the feeding mechanism to cause a book to be deposited when the rear end of the preceding book is advanced beyond the forward end of the book to be deposited, substantially as set forth.

9. In a machine for applying binding strips to the backs or binding edges of books, the combination with pasting mechanism for the binding strip and feeding mechanism for advancing the books and strip through the machine, of a book depositing mechanism for depositing successive books upon the pasted strip, and means for controlling the book depositing mechanism by the books successively advanced by the feeding mechanism, substantially as set forth.

10. In a machine for applying binding strips to the backs or binding edges of books, the combination with feeding mechanism for advancing the books through the machine, of a book depositing mechanism for supplying successive books to the feeding mechanism, means for controlling the book depositing mechanism by the books successively advanced by the feeding mechanism, and means for automatically reducing the rate of movement of the book depositing mechanism when no book is in position to control its movement, substantially as set forth.

11. In a machine for applying binding strips to the backs or binding edges of books, the

combination with feeding mechanism for advancing the books through the machine, of a book depositing mechanism for supplying successive books to the feeding mechanism, a tripping mechanism co-operating with the books successively advanced by the feeding mechanism and controlling the book depositing mechanism, and means for automatically controlling the rate of movement of the book depositing mechanism when no book is in position to control the tripping mechanism, substantially as described.

12. In a machine for applying binding strips to the backs or binding edges of books, the combination with feeding mechanism for advancing the books and attached strip through the machine, of mechanism for severing the strip between the books, and means for controlling the severing mechanism by the books to cause the strip to be severed at intervals varying with the lengths of the books, substantially as described.

13. In a machine for applying binding strips to the backs or binding edges of books, the combination with feeding mechanism for advancing the books and attached strip through the machine, of mechanism for severing the strip between the books, and a tripping mechanism co-operating with the books to cause the severing mechanism to be brought into action at intervals varying with the lengths of the books, substantially as set forth.

14. In a machine for applying binding strips to the backs or binding edges of books, the combination of feeding mechanism for advancing the books and attached binding strip through the machine, mechanism for severing the strip between the books, a tripping mechanism co-operating with the books to cause the severing mechanism to be brought into action, and mechanism for arresting the feeding mechanism during the severing operation and restarting said mechanism when the severing operation is completed, substantially as set forth.

15. In a machine for applying binding strips to the backs or binding edges of books, the combination of pasting mechanism for the binding strip, a table upon which the binding strip travels with its pasted side uppermost, book depositing mechanism for depositing the books on the binding strip, a series of rolls for feeding the books and strip forward, folding guides for folding the edges of the strip against the edges of the books, pressure rolls for smoothing the turned up edges of said strip and means for severing the binding strip between the books, substantially as set forth.

16. The combination with feeding mechanism for the strip, of a pasting roll engaging and actuated by the advancing strip, a paste fountain supplying paste to said roll, and means for positively driving said pasting roll when the strip is moved out of engagement with the roll, substantially as described.

17. The combination with the pasting and

fountain rolls, of an oscillating shaft m , and a guide roll for the strip and driving mechanism for the paste roll carried by arms on said shaft, whereby the driving mechanism may be thrown into and out of operation and the strip simultaneously carried out of or into engagement with the paste roll, substantially as described.

18. The combination with the pasting and fountain rolls, of an oscillating shaft m , a guide roll for the strip and driving mechanism for the paste roll carried by arms on said shaft, whereby the driving mechanism may be thrown into and out of operation and the strip simultaneously carried out of or into engagement with the paste roll, and a weighted arm n on the shaft m , substantially as described.

19. The combination with feeding mechanism for the strip, of a paste roll rotated by contact with the strip, driving mechanism for said paste roll normally out of operation, and means for simultaneously moving the strip out of engagement with said roll and bringing the driving mechanism into operation, substantially as set forth.

20. The combination with the binding strip, the pasting roll, a pair of guide rolls for the strip mounted in a suitable support or framing, a fountain provided with a roll in frictional contact with said pasting roll and friction pulleys mounted upon the shafts of the pasting and fountain rolls, of a driven friction pulley, as k , a second pulley as l on the shaft carrying the lowermost of the aforesaid guide rolls for the strip, a weighted arm secured to the end of said last mentioned shaft and which in its normal position maintains said pulleys l out of engagement with pulley k and with friction pulley on shaft of pasting roll, and the uppermost guide roll in position to direct the binding strip against the periphery of the pasting roll, and when swung out of its normal position carries pulley l into frictional contact with said pulley k and the friction pulley on the shaft of the pasting roll, thereby continuing the revolution of the pasting and fountain rolls and holding said uppermost guide roll and the pasting strip away from contact with said pasting roll, substantially as set forth.

21. The combination with the pasting and fountain rolls supported as shown, shaft m mounted to oscillate in suitable bearings and carrying arms p , a frame connected to arms p and supporting a guide roll, and friction pulleys g, g , of short shaft r carrying driven friction pulley k , friction pulley l mounted on a crank on one end of shaft m , and weighted arm n mounted on the other end of said shaft, substantially as described.

22. The combination with the table upon which the pasted strip is adapted to travel, of a rack to receive the books, brackets provided with pivoted hooks to support the books in a vertical position when discharged from the rack, and guides arranged to act upon the

lower edges of the books to guide them accurately to the center of the binding strip, mechanism for vibrating the rack to deposit the books onto the binding strip and feeding rolls supported on the table in advance of said rack, substantially as set forth.

23. The combination with the supporting table and shaft 51, of the vibrating book rack mounted on said shaft and provided with stops for supporting the books thereon and with a stop, as 3, determining the proper position of the forward end of the books, brackets and guides for supporting the books in a vertical position and guiding their lower edges, and mechanism for vibrating said rack, substantially as set forth.

24. The combination with the vibrating book rack mounted upon a shaft and having attached to its lower side adjustable stops for supporting the book thereon, said stops provided upon their sides with studs, as 4, of a plate or bracket provided with a cam groove eccentric to the shaft of the vibrating rack and co-operating with studs 4, whereby when the rack is lowered to its inclined position the stops will protrude above the surface of the rack and when raised to its vertical position said stops will be drawn inward to permit the book to slide freely off the rack, substantially as set forth.

25. The combination with the vibrating book rack, its supporting table and a shaft upon which said rack is mounted, of an arm fixed to said shaft, a lever fulcrumed beneath the table, connected to said arm and provided with a stud or bowl, a cam having a gear secured to its side and co-operating with the bowl on said lever to rock the latter, said cam being mounted loosely on a shaft 57 operatively geared with the main driving shaft, a gear loose upon shaft 57, a disk keyed fast to said shaft and adapted to drive the last mentioned gear through a frictional connection, and a counter-shaft provided with gears meshing with said disk gear and frictionally driven gear on said shaft 57, substantially as set forth.

26. The combination with the vibrating book rack, a shaft upon which said rack is mounted, its supporting table, arm 52, rod 53, and lever 54 fulcrumed beneath said supporting table and provided with a stud or bowl, of cam 56 having secured thereto a gear wheel mounted loosely upon shaft 57 and co-operating with said bowl on lever 54, sprocket wheel and chain driving shaft 57 from the main driving shaft, disk 62 keyed fast to shaft 57 and provided with flanges, as 46, gear 63 loose upon said shaft 57, wear pieces as 45, located between the flanges of said disk and the hub of gear 63 to provide a frictional connection between said gear and disk, and a counter-shaft provided with gears co-operating with the cam gear and frictionally driven gear, substantially as set forth.

27. The combination with the book rack mounted upon a supporting table, and mech-

anism including a lever and cam for vibrating said book rack, the said cam provided with studs in its periphery co-operating with a spring hook, whereby the motion of the cam is temporarily arrested, of a tripping lever fulcrumed on the supporting table in proper relation to the vibrating book-rack, a lever fulcrumed beneath the table and connected at one end through a stud to said tripping lever, a spring adjusted to rock the lever beneath the table and, through the medium of the latter lever, rock said tripping lever slightly inward when the rear end of the book has passed the head of said tripping lever, substantially as set forth.

28. The combination with the book-rack, mechanism for vibrating the same, a binding strip and a book carried thereby, of a tripping lever located in proper relation to the book rack and provided with a supplemental lever locked in position by a dog, as 39, a lever fulcrumed beneath the support for the binding strip and a spring exerting pressure on said last mentioned lever to hold the head of said supplemental lever against the book and to rock the said lever inward slightly when the rear end of the book has passed the head of the supplemental lever, substantially as set forth.

29. The combination with the book rack and mechanism for vibrating the same, of a tripping lever 68, fulcrumed in proper relation to the book rack, and having pivoted thereto a supplemental lever provided with a head projecting slightly beyond the end of lever 68 and also a tripping dog as 39, provided with a head 7 projecting beyond the inner side of the tripping lever and with a stud 8 bearing against the inner side of the supplemental lever, said dog engaging with a shoulder on the supplemental lever to lock and hold said lever with its head 40 projecting slightly beyond the tripping lever, a spring normally holding the tripping dog in position to lock the supplemental lever, a lever, as 71, fulcrumed beneath the book rack support and connected with the tripping lever, and a spring co-operating with the lever 71 to rock the same and the connected tripping lever so as to press the head 40 of the supplemental lever against the lower edges of the sides of the books, substantially as set forth.

30. The combination with the book-rack and mechanism for vibrating the same, including a lever and cam, the latter provided with studs in its periphery and a corresponding number of projections, as 81, on its face, of a tripping lever located in proper relation to the book-rack, a lever, as 71, pivoted beneath the support for the book rack and connected indirectly at one end with the tripping lever and provided at its other end with a fork, and with lateral projection 82 to coact with said projections 81 on the cam, a clutch on shaft 57, the movable member of which is provided with a loose band to which said fork is secured, a rod, as 75, connected to lever

71 and co-operating with a pivoted latch, a spring-actuated bolt provided with a collar having a stud with which said latch engages, said bolt coacting with the lever 71 to rock the same to cause the two members of the clutch to engage and lock the afore-mentioned cam to its shaft, and a horizontal vibrating lever co-operating at one end with the collar on said spring actuated bolt and at its other end with the studs in the periphery of said cam, substantially as set forth.

31. The combination with the cam 56 located upon shaft 57, lever 71 provided at one end with a fork and connected at its other end with a stud, as 70, a clutching device located on said shaft 57 and to the movable member of which the fork of said lever is connected, of a hand lever, as 79, fulcrumed at 80 and provided at its inner end with a shoulder which engages with a projection on stud 70, whereby said stud and lever 71 are held in position to prevent the clutching of the aforesaid cam to its shaft, substantially as set forth.

32. The combination with the book rack and mechanism for vibrating the same, including a lever and a cam, the latter having studs in its periphery, and a tripping lever located in proper relation to the book rack, of a lever 71 fulcrumed beneath the support for the book rack and co-operating with said cam and with a clutch on the shaft upon which said cam is mounted, a rod 75 connected to the opposite end of lever 71, a pivoted latch the arm of which enters a recess in said rod, a spring actuated bolt provided with a collar having a stud with which said latch co-operates, a spring, as 33, to rock and hold the latch in engagement with said stud and the spring-actuated bolt in position to prevent it from rocking the lever 71, a horizontal vibrating lever the forward end of which enters a recess in the collar on the spring actuated bolt, and its opposite end provided with an inclined surface engaging with the studs in the periphery of the cam to rock said lever and compress the spring on said bolt, and a spring, as 78, to rock the lever in the opposite direction, substantially as set forth.

33. The combination with the tripping and clutching mechanism including lever 71 and cam 56, of a loose disk frictionally connected to shaft 57 and also connected to the hub of said cam 56 and provided around its edge with recesses, a lever as 85 fulcrumed so that its rear end extends above said disk and is provided with a lug adapted to enter said recesses, a vertically sliding block provided with a tooth and beneath which the forward end of said lever terminates, said block having a transverse opening through which passes a horizontally sliding block also provided with a tooth, a rod connecting said horizontal block with the end of lever 71, and a spring which rocks lever 85 to raise said vertically sliding block when the lug on the le-

ver enters one of the recesses in the aforesaid loose disk, substantially as set forth.

34. The combination with the clutching and tripping mechanism including lever 71 and cam 56, the latter mounted on shaft 57, of loose disk 83 provided with recesses in its edge and frictionally connected to said shaft by a second disk fast upon the shaft and provided with flanges overlapping a portion of disk 83, frictional pieces bearing upon disk 83, a pin connecting disk 83 to the hub of cam 56 whereby when the cam is clutched to the shaft 57 said cam will revolve a predetermined distance before its motion is imparted to disk 83, a lever pivoted to a bracket and provided at its rear end with a lug co-operating with the recesses in said disk, a vertically sliding block having a tooth, beneath which block the forward end of said lever terminates, a horizontally sliding block passing through a transverse opening in the first mentioned block and also having a tooth, a rod connecting said horizontal block with the end of lever 71 and a spring 25 co-operating with said lever, substantially as set forth.

35. The combination with the table for carrying the pasted binding strip, of a series of book feeding rolls supported vertically in pairs, horizontally supported rolls adjustable vertically to bear on the upper edges of the books and means for folding the edges of the binding strip against the sides of the books, substantially as described.

36. The combination with the table, for carrying the pasted binding strip, of a series of book feeding rolls supported vertically in pairs and adjustable vertically to bear upon the books at the proper height and to be made to conform to books of different widths, horizontally supported rolls adjustable vertically to bear on the upper edges of the books and means for folding the edges of the binding strip against the sides of the books, substantially as described.

37. The combination with the table, the traveling binding strip supported thereon, and a pair of guide rolls vertically supported on said table, of curved folding guides located in advance of said guide rolls and acting upon the edges of the binding strip projecting beyond the sides of the books carried by said strip to fold said edges upward against the sides of the books, substantially as set forth.

38. The combination with the table, traveling binding strip supported thereon and folding guides, of a pair of pressing and smoothing rolls located in advance of the folding guides and serving to press and smooth the edges of the binding strip against the sides of the books carried by said strip after said edges have been turned up by the folding guides, substantially as set forth.

39. The combination with the table, traveling binding strip supported thereon, feeding rolls vertically supported on said table and folding guides, of a pair of inclined pressing and smoothing rolls co-operating with the

edges of the binding strip, substantially as set forth.

40. The combination with the table and traveling binding strip supported thereon, of inclined pressing rolls 97, pulleys 99 secured to or integral with pulleys 94 mounted upon the main driving shaft, belts 98 and guide pulleys secured to the lower ends of the shafts of said inclined pulleys, substantially as set forth.

41. The combination with the table and traveling binding strip supported thereon, of vertically arranged feeding rolls 50, 89, 90, brackets therefor connected to plates located beneath the table, plates 105 connected to plates 103 of the brackets of rolls 89, 90, and forming nuts for a right and left hand screw shaft fixed in bearings secured to the under side of the table and provided with a gear engaging with a gear upon shaft 109 provided with a second gear engaging with a gear upon a right and left hand threaded shaft, as 111, passing through nuts formed in plates 50, and a handle connected to the end of said shaft 111, whereby all of the rolls of the series may be simultaneously adjusted to conform to books of different thicknesses, substantially as set forth.

42. The combination with the table, binding strip traveling thereon, book feeding rolls for advancing the books and attached strip, and folding guide plates and pressing rolls for folding and pressing the strip on the sides of the book, of a severing knife or knives and a mechanism for automatically operating said knives to sever the binding strip between the books on said strip, substantially as described.

43. The combination with the table and binding strip traveling thereon, of severing knives 113 provided with oppositely arranged racks, a gear, as 115, located between said racks, an arm connected to the shaft of the gear and connected at its opposite end by means of a rod to a lever, as 118, which lever is fulcrumed beneath the supporting table, and a cam mounted loosely upon the main shaft and co-operating with the free end of said lever and mechanism for clutching the cam to the main shaft at proper intervals to operate the knives to sever the binding strip, substantially as set forth.

44. The combination with a clutch mechanism, of the clutch lever 126 adapted to engage one member of the clutch, the bell crank lever 125, the end of the latter provided with a stud, as 16, adapted to engage the clutch lever, and connected to the clutch lever by a hoop like spring 130, and means for operating said bell crank lever, substantially as described.

45. The combination with a table, binding strip traveling thereon, and knives for severing said strip, of an arm spring pressed and pivoted so that its free end bears against the sides of the books carried by said strip, and connections between said arm and the knives

whereby, when the free end of the arm moves inward after a book has passed it, the knives will be operated to sever the strip, substantially as described.

46. The combination with a table, binding strip traveling thereon, and knives for severing said strip, of an arm spring pressed and pivoted so that its free end bears against the sides of the books carried by said strip, a lever by which the knives are operated, a cam for operating said lever loosely sleeved on a driving shaft, a clutch for connecting the cam to the shaft, and connections between the clutch and the said cam whereby, when the free end of the arm moves inward after a book has passed it, the clutch will be operated to connect the cam to the shaft, substantially as described.

47. The combination with a table, a traveling binding strip thereon, and knives for severing said strip, of an arm 121 fulcrumed to a stud passing through the table, a tripping lever connected to the lower end of said stud, a spring tending to rock and hold the end of arm 121 against the sides of the books carried by the binding strip, a lever by which the knives are operated, a cam for operating said lever loosely sleeved on a driving shaft, a clutch for connecting said cam to the shaft, a clutch lever adapted to engage one member of the clutch, a bell crank lever operating said clutch lever, and a system of pivoted dogs and springs co-operating with the free end of the tripping lever and with the bell crank lever so that, when the end of the arm 121 moves inward after a book has passed it, the clutch will be operated to connect the cam to the shaft, substantially as described.

48. The combination with cams 120, 131, mounted upon the main driving shaft, a lever 132 engaging with cam 131 and provided at its free end with two inclined studs, as 133, 134, of clutch lever 123 provided at its free end with an opening as 135, with which inclined stud 133 is adapted to co-operate to restore said clutch lever to its normal position, thereby rocking the arm 121 fulcrumed to the top of the strip supporting table to move the end of said arm outward, and the latter stud 134 co-operating with the inclined end of dog 19, substantially as and for the purpose set forth.

49. The combination with arm 121 fulcrumed to the top of the table as described, tripping lever 123 and spring 124, of the severing knives, lever 118 connected to the gear of said knives, rod 137, shaft 138, bell crank lever 125 provided with a stud in its end, clutch lever 126, spring 130 connecting the end of said bell crank lever with the clutch lever and clutches and pulleys mounted on the main driving shaft, substantially as set forth.

50. The combination with arm 121 provided with a head 22 and fulcrumed to the top of the table, spring controlled tripping lever, severing knives and means for reciprocating

the same including lever 118, bell crank lever 125 adapted to be rocked through said lever 118, clutch lever 126 connected by a spring to said bell crank lever as described, a double
 5 clutch and cams and pulleys supported on the main driving shaft, the free end of lever 118 co-operating with the abrupt shoulders on one of said cams (120), of lever 132 co-operating at one end with shoulders on the edge
 10 of one of said cams (131) co-operating with the free end of lever 123, and springs 140, 141 coacting with levers 132, 118, substantially as set forth.

51. The combination with the severing
 15 knives and mechanism for automatically reciprocating the same, spring 124, lever 123, and cams 120, 131, of cam 142 loose upon the main driving shaft but connected frictionally thereto by disk 143 fast upon said shaft, the
 20 said cam 142 provided with notches in its periphery, as shown, and having a slot 150 in its side which receives a stud 149 projecting from cams 120, 131, whereby said cams and disk are connected together, a lever 146 ful-
 25 crumed upon a bracket depending from the under side of the table and provided with a spring and having at one end a lug co-operating with the notches in the periphery of cam 142 and the opposite end thereof engag-
 30 ing with said lever 123 to retain the same temporarily in the position to which it has been rocked by lever 132, substantially as set forth.

52. The combination with arm 121 ful-
 35 crumed to the top of the table, lever 123 and severing knives and their operating mechanism, of a spring seated presser plate arranged on the surface of the table opposite the end
 40 of said arm 121 and the binding strip carrying the books, substantially as set forth.

53. The combination with the table sup-
 45 porting the traveling binding strip and an arm 121 provided with a projecting end, as 22, having upon its under side a ratchet, of spring seated presser plate 151 located oppo-
 50 site the end 22 of said arm 121 and provided with a lateral extension having a pawl which engages with the ratchet on arm 121, substantially as set forth.

54. The combination with book feeding
 55 mechanism, of a book depositing mechanism for delivering books to the feeding mechanism, a presser foot engaging a book as it is advanced by the feeding mechanism, and
 60 connections whereby the movements of the book depositing mechanism are controlled by the presser foot, substantially as described.

55. The combination with book feeding
 60 mechanism, of a book depositing mechanism for delivering books to the feeding mechanism, a presser foot engaging a book as it is advanced by the feeding mechanism, and con-
 65 nections whereby the book depositing mechanism is actuated to deliver a book when the book being advanced by the feeding mecha-

ism has passed the presser foot, substantially as described.

56. The combination with book feeding
 70 mechanism, of a book depositing mechanism for delivering books to the feeding mechanism, a presser foot engaging a book as it is advanced by the feeding mechanism, connections whereby the book depositing mechanism is actuated to deliver a book when the
 75 book being advanced by the feeding mechanism has passed the presser foot, and means whereby the further operation of the book depositing mechanism is controlled if no book be delivered, substantially as described.

57. The combination with feeding mecha-
 80 nism for advancing books and an attached strip, of a knife or knives for severing said strip between the books, a presser foot engaging the books as they are advanced by the
 85 feeding mechanism, and connections whereby the movements of the knife are controlled by the presser foot, substantially as described.

58. The combination with feeding mecha-
 90 nism for advancing books and an attached strip, of a knife or knives for severing said strip between the books, a presser foot engaging the books as they are advanced by the
 95 feeding mechanism, and connections whereby the knife is actuated to sever the strip behind a book after the latter has passed the presser foot, substantially as described.

59. The combination with feeding mecha-
 100 nism for advancing books and an attached strip, of a knife or knives for severing said strip between the books, a presser foot engaging the books as they are advanced by the
 105 feeding mechanism, and connections whereby the operation of the feeding mechanism and knife are controlled by the presser foot, substantially as described.

60. The combination with feeding mecha-
 110 nism for advancing books and an attached strip, of a knife or knives for severing said strip between the books, a presser foot engaging the books as they are advanced by the
 115 feeding mechanism, and connections whereby the feeding mechanism is stopped and the knife actuated to sever the strip behind a book after the latter has passed the presser foot, substantially as described.

61. The combination with feeding mecha-
 120 nism for advancing books and an attached strip, of a knife or knives for severing said strip between the books, a presser plate engaged by the books, and connections whereby
 125 the operation of the knife is prevented when the presser plate is not engaged by a book, substantially as described.

In testimony whereof I have hereunto set
 my hand in the presence of two subscribing
 witnesses.

JOSEPH I. KNIGHT.

Witnesses:

PETER MOSEMAN,
 BENJIMAN F. BURNETT.