



- (51) International Patent Classification:
C07C 2/82 (2006.01) C07C 2/08 (2006.01)
C07C 2/84 (2006.01)
- (21) International Application Number:
PCT/US2015/010688
- (22) International Filing Date:
8 January 2015 (08.01.2015)
- (25) Filing Language: English
- (26) Publication Language: English
- (30) Priority Data:
61/925,627 9 January 2014 (09.01.2014) US
61/955,112 18 March 2014 (18.03.2014) US
61/996,789 14 May 2014 (14.05.2014) US
62/050,720 15 September 2014 (15.09.2014) US
62/073,478 31 October 2014 (31.10.2014) US
62/086,650 2 December 2014 (02.12.2014) US

Dolores Street, San Francisco, CA 94110 (US). **MC-CORMICK, Jarod**; 952 Rosewood Avenue, San Carlos, CA 94070 (US). **IYER, Rahul**; 105 Kenyon Avenue, Kensington, CA 94708 (US). **DUGGAL, Suchia**; 1040 Cresta Way #07, San Rafael, CA 94903 (US). **CIZERON, Joel**; 923 Emerald Hill Road, Redwood City, CA 94061 (US). **HONG, Jin, Ki**; 2063 Ascot Drive #215, Moraga, CA 94556 (US).

(74) Agents: **ALEMOZAFAR, Ali, R.** et al.; Wilson Sonsini Goodrich & Rosati, 650 Page Mill Road, Palo Alto, CA 94304-1050 (US).

- (31) Applicant: **SILURIA TECHNOLOGIES, INC.** [US/US]; 409 Illinois Street, San Francisco, CA 94158 (US).
- (72) Inventors: **RAFIQUE, Humera, A.**; 5156 Montiano Lane, Dublin, CA 94568 (US). **VUDDAGIRI, Srinivas**; 2951 Audubon Circle, Davis, CA 95618 (US). **HARRAZ, Hatem**; 1049 Virginia Street, Berkeley, CA 94710 (US). **RADAELLI, Guido**; 21 Buena Vista Road, South San Francisco, CA 94080 (US). **SCHER, Erik, C.**; 1518

(81) Designated States (unless otherwise indicated, for every kind of national protection available): AE, AG, AL, AM, AO, AT, AU, AZ, BA, BB, BG, BH, BN, BR, BW, BY, BZ, CA, CH, CL, CN, CO, CR, CU, CZ, DE, DK, DM, DO, DZ, EC, EE, EG, ES, FI, GB, GD, GE, GH, GM, GT, HN, HR, HU, ID, IL, IN, IR, IS, JP, KE, KG, KN, KP, KR, KZ, LA, LC, LK, LR, LS, LU, LY, MA, MD, ME, MG, MK, MN, MW, MX, MY, MZ, NA, NG, NI, NO, NZ, OM, PA, PE, PG, PH, PL, PT, QA, RO, RS, RU, RW, SA, SC, SD, SE, SG, SK, SL, SM, ST, SV, SY, TH, TJ, TM, TN, TR, TT, TZ, UA, UG, US, UZ, VC, VN, ZA, ZM, ZW.

(84) Designated States (unless otherwise indicated, for every kind of regional protection available): ARIPO (BW, GH, GM, KE, LR, LS, MW, MZ, NA, RW, SD, SL, ST, SZ, TZ, UG, ZM, ZW), Eurasian (AM, AZ, BY, KG, KZ, RU, TJ, TM), European (AL, AT, BE, BG, CH, CY, CZ, DE,

[Continued on next page]

(54) Title: OXIDATIVE COUPLING OF METHANE IMPLEMENTATIONS FOR OLEFIN PRODUCTION

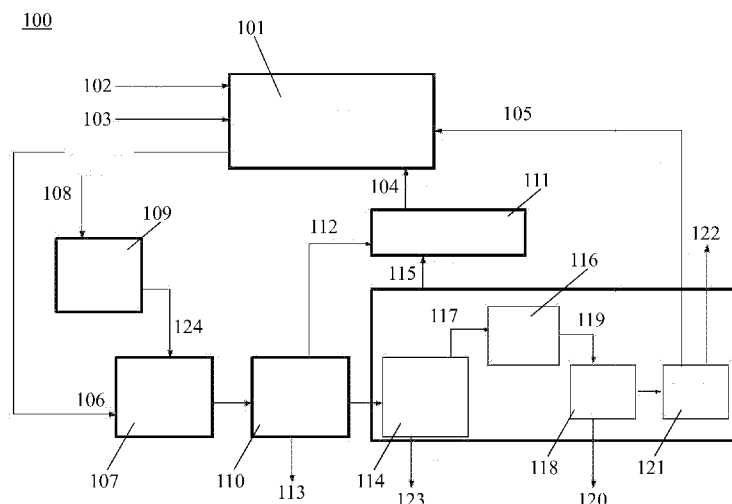

FIG. 1

(57) Abstract: The present disclosure provides oxidative coupling of methane (OCM) systems for small scale and world scale production of olefins. An OCM system may comprise an OCM subsystem that generates a product stream comprising C₂₊ compounds and non-C₂₊ impurities from methane and an oxidizing agent. At least one separations subsystem downstream of, and fluidically coupled to, the OCM subsystem can be used to separate the non-C₂₊ impurities from the C₂₊ compounds. A methanation subsystem downstream and fluidically coupled to the OCM subsystem can be used to react H₂ with CO and/or CO₂ in the non-C₂₊ impurities to generate methane, which can be recycled to the OCM subsystem. The OCM system can be integrated in a non-OCM system, such as a natural gas liquids system or an existing ethylene cracker.

WO 2015/106023 A1

DK, EE, ES, FI, FR, GB, GR, HR, HU, IE, IS, IT, LT,
LU, LV, MC, MK, MT, NL, NO, PL, PT, RO, RS, SE,
SI, SK, SM, TR), OAPI (BF, BJ, CF, CG, CI, CM, GA,
GN, GQ, GW, KM, ML, MR, NE, SN, TD, TG).

— *before the expiration of the time limit for amending the
claims and to be republished in the event of receipt of
amendments (Rule 48.2(h))*

Published:

— *with international search report (Art. 21(3))*

OXIDATIVE COUPLING OF METHANE IMPLEMENTATIONS FOR OLEFIN PRODUCTION

CROSS-REFERENCE

[0001] This application claims the benefit of U.S. Provisional Patent Application Serial Number 61/925,627, filed January 9, 2014, U.S. Provisional Patent Application Serial Number 61/955,112, filed March 18, 2014, U.S. Provisional Patent Application Serial Number 61/996,789, filed May 14, 2014, U.S. Provisional Patent Application Serial Number 62/050,720, filed September 15, 2014, U.S. Provisional Patent Application Serial Number 62/073,478, filed October 31, 2014, and U.S. Provisional Patent Application Serial Number 62/086,650, filed December 2, 2014, each of which is entirely incorporated herein by reference.

BACKGROUND

[0002] The modern petrochemical industry makes extensive use of cracking and fractionation technology to produce and separate various desirable compounds from crude oil. Cracking and fractionation operations are energy intensive and generate considerable quantities of greenhouse gases.

[0003] The gradual depletion of worldwide petroleum reserves and the commensurate increase in petroleum prices may place extraordinary pressure on refiners to minimize losses and improve efficiency when producing products from existing feedstocks, and also to seek viable alternative feedstocks capable of providing affordable hydrocarbon intermediates and liquid fuels to downstream consumers.

[0004] Methane may provide an attractive alternative feedstock for the production of hydrocarbon intermediates and liquid fuels due to its widespread availability and relatively low cost when compared to crude oil. Worldwide methane reserves may be in the hundreds of years at current consumption rates and new production stimulation technologies may make formerly unattractive methane deposits commercially viable.

[0005] Ethylene is an important commodity chemical intermediate. The worldwide production of ethylene exceeds that of any organic compound. Ethylene is used in the production of polyethylene plastics, polyvinyl chloride, ethylene oxide, ethylene chloride, ethylbenzene, alpha-olefins, linear alcohols, vinyl acetate, and fuel blendstocks such as, but not limited to, aromatics, alkanes and alkenes. The growth in demand for ethylene and ethylene based derivatives is forecast to increase as the developing world continues to register higher economic growth. The bulk of worldwide annual commercial production of ethylene is based on thermal cracking of petroleum hydrocarbons with steam; the process is commonly called pyrolysis or steam

cracking. The feedstocks for steam cracking can be derived either from crude oil (e.g., naphtha) or from associated or natural gas (e.g., ethane, propane, LPG). Ethylene production is primarily limited to high volume production as a commodity chemical in relatively large steam crackers or other petrochemical complexes that also process the large number of other hydrocarbon byproducts generated in the steam cracking process. Producing ethylene from far more abundant and significantly less expensive methane in natural gas provides an attractive alternative to ethylene produced from steam cracking (e.g., naphtha or gaseous feedstocks). Oligomerization processes can be used to further convert ethylene into longer chain hydrocarbons useful as polymer components for plastics, vinyls, and other high value polymeric products. Additionally, these oligomerization processes may be used to convert ethylene to other longer hydrocarbons, such as C₆, C₇, C₈ and longer hydrocarbons useful for fuels like gasoline, diesel, jet fuel and blendstocks for these fuels, as well as other high value specialty chemicals.

SUMMARY

[0006] Recognized herein is the need for efficient and commercially viable systems and methods for converting methane to higher chain hydrocarbons, such as hydrocarbon compounds with two or more carbon atoms (also “C₂₊ compounds” herein), such as olefins and/or alkanes. An oxidative coupling of methane (“OCM”) reaction is a process by which methane can form one or more C₂₊ compounds.

[0007] In an OCM process, methane is oxidized to yield products comprising C₂₊ compounds, including alkanes (e.g., ethane, propane, butane, pentane, etc.) and alkenes (e.g., ethylene, propylene, etc.). Such alkane (also “paraffin” herein) products may not be suitable for use in downstream processes. Unsaturated chemical compounds, such as alkenes (or olefins), may be employed for use in downstream processes. Such compounds may be polymerized to yield polymeric materials, which may be employed for use in various commercial settings.

[0008] An aspect of the present disclosure provides oxidative coupling of methane (OCM) system for small scale or world scale production of olefins, comprising: (a) an OCM subsystem that (i) takes as input a feed stream comprising methane (CH₄) and a feed stream comprising an oxidizing agent, and (ii) generates from the methane and the oxidizing agent a product stream comprising C₂₊ compounds and non-C₂₊ impurities; and (b) at least one separations subsystem downstream of, and fluidically coupled to, the OCM subsystem, wherein the separations subsystem comprises a first heat exchanger, a de-methanizer unit downstream of the first heat exchanger, and a second heat exchanger downstream of the de-methanizer unit, wherein (1) the first heat exchanger cools the product stream, (2) the de-methanizer unit accepts the product stream from the first heat exchanger and generates an overhead stream comprising methane and

at least a portion of the non-C₂₊ impurities, and a bottoms stream comprising at least a portion of the C₂₊ compounds, and (3) at least a portion of the overhead stream is cooled in the second heat exchanger and is subsequently directed to the first heat exchanger to cool the product stream.

[0009] In some embodiments of aspects provided herein, the overhead stream is split into at least two streams, and at least one of the two streams is pressurized prior to introduction to the second heat exchanger. In some embodiments of aspects provided herein, the system further comprises a hydrogenation unit downstream of the de-methanizer, wherein the hydrogenation unit accepts a stream comprising the C₂₊ compounds and hydrogenates alkynes in the C₂₊ compounds to alkanes and/or alkenes. In some embodiments of aspects provided herein, the system further comprises a de-ethanizer unit downstream of the hydrogenation unit, wherein the de-ethanizer unit accepts the stream and separates ethane from ethylene. In some embodiments of aspects provided herein, the system further comprises a methanation subsystem upstream of the OCM subsystem, wherein the methanation subsystem reacts H₂ with CO and/or CO₂ to generate methane, which methane is directed to the OCM subsystem. In some embodiments of aspects provided herein, the system further comprises a sulfur removal subsystem upstream of the OCM subsystem, wherein the sulfur removal subsystem accepts a feed stream comprising methane and decrease the concentration of sulfur in the feed stream. In some embodiments of aspects provided herein, the sulfur removal subsystem further comprises a heat recovery steam generator unit. In some embodiments of aspects provided herein, the system further comprises an absorption system downstream of the OCM subsystem, wherein the absorption system decreases the concentration of CO₂ in the product stream. In some embodiments of aspects provided herein, the absorption system comprises an absorption unit and a scrubber downstream of the absorption unit. In some embodiments of aspects provided herein, the oxidizing agent is O₂. In some embodiments of aspects provided herein, the O₂ is provided by air. In some embodiments of aspects provided herein, the OCM subsystem comprises at least one OCM reactor. In some embodiments of aspects provided herein, the OCM subsystem comprises at least one post-bed cracking unit downstream of the at least one OCM reactor, which post-bed cracking unit is configured to convert at least a portion of alkanes in the product stream to alkenes. In some embodiments of aspects provided herein, the system further comprises a non-OCM process upstream of the OCM subsystem. In some embodiments of aspects provided herein, the non-OCM process is a natural gas liquids process. In some embodiments of aspects provided herein, the non-C₂₊ impurities comprise one or more of nitrogen (N₂), oxygen (O₂), water (H₂O), argon (Ar), carbon monoxide (CO), carbon dioxide (CO₂) and CH₄.

[0010] An aspect of the present disclosure provides an oxidative coupling of methane (OCM) system for small scale or world scale production of olefins, comprising: (a) an OCM subsystem that (i) takes as input a feed stream comprising methane (CH_4) and a feed stream comprising an oxidizing agent, and (ii) generates from the methane and the oxidizing agent a product stream comprising C_{2+} compounds and non- C_{2+} impurities; and (b) at least one methanation subsystem downstream of, and fluidically coupled to, the OCM subsystem, wherein the methanation subsystem reacts H_2 and CO and/or CO_2 included in the non- C_{2+} impurities to generate methane.

[0011] In some embodiments of aspects provided herein, at least a portion of the methane generated in the methanation subsystem is recycled to the OCM subsystem. In some embodiments of aspects provided herein, the oxidizing agent is O_2 . In some embodiments of aspects provided herein, the O_2 is provided by air. In some embodiments of aspects provided herein, the OCM subsystem comprises at least one OCM reactor. In some embodiments of aspects provided herein, the OCM subsystem comprises at least one post-bed cracking unit downstream of the at least one OCM reactor, which post-bed cracking unit is configured to convert at least a portion of alkanes in the product stream to alkenes. In some embodiments of aspects provided herein, the system further comprises a non-OCM process upstream of the OCM subsystem. In some embodiments of aspects provided herein, the non-OCM process is a natural gas liquids process. In some embodiments of aspects provided herein, the non- C_{2+} impurities comprise one or more of nitrogen (N_2), oxygen (O_2), water (H_2O), argon (Ar), carbon monoxide (CO), carbon dioxide (CO_2) and CH_4 . In some embodiments of aspects provided herein, the methanation subsystem comprises at least one methanation reactor.

[0012] An aspect of the present disclosure provides a catalyst for hydrogenation of acetylene in an oxidative coupling of methane (OCM) process comprising at least one metal element, wherein the catalyst is capable of decreasing the concentration of acetylene to less than about 100 parts per million (ppm) in an OCM effluent.

[0013] In some embodiments of aspects provided herein, the catalyst is capable of decreasing the concentration of acetylene to less than about 10 ppm in the OCM effluent. In some embodiments of aspects provided herein, the catalyst is capable of decreasing the concentration of acetylene to less than about 1 ppm in the OCM effluent. In some embodiments of aspects provided herein, the at least one metal element is palladium. In some embodiments of aspects provided herein, the at least one metal element is part of a metal oxide. In some embodiments of aspects provided herein, the catalyst is capable of providing an OCM effluent that comprises at least about 0.5% carbon monoxide. In some embodiments of aspects provided herein, the catalyst is capable of providing an OCM effluent that comprises at least about 1% carbon monoxide. In some

embodiments of aspects provided herein, the catalyst is capable of providing an OCM effluent that comprises at least about 3% carbon monoxide. In some embodiments of aspects provided herein, the catalyst has a lifetime of at least about 1 year. In some embodiments of aspects provided herein, the catalyst is capable of providing an OCM effluent that comprises at least about 0.1% acetylene. In some embodiments of aspects provided herein, the catalyst is capable of providing an OCM effluent that comprises at least about 0.3% acetylene. In some embodiments of aspects provided herein, the catalyst is capable of providing an OCM effluent that comprises at least about 0.5% acetylene. In some embodiments of aspects provided herein, the at least one metal element comprises a plurality of metal elements.

[0014] An aspect of the present disclosure provides a catalyst for converting carbon monoxide (CO) and/or carbon dioxide (CO₂) into methane (CH₄) in an oxidative coupling of methane (OCM) process, wherein the catalyst comprises at least one metal element for converting CO and/or CO₂ into CH₄ at a selectivity for the formation of methane that is at least about 10-fold greater than the selectivity of the catalyst for formation of coke in an OCM effluent.

[0015] In some embodiments of aspects provided herein, the catalyst has a selectivity for the formation of methane that is at least about 100-fold greater than the selectivity of the catalyst for formation of coke. In some embodiments of aspects provided herein, the catalyst has a selectivity for the formation of methane that is at least about 1000-fold greater than the selectivity of the catalyst for formation of coke. In some embodiments of aspects provided herein, the catalyst has a selectivity for the formation of methane that is at least about 10000-fold greater than the selectivity of the catalyst for formation of coke. In some embodiments of aspects provided herein, the OCM effluent comprises at least about 3% olefin and/or acetylene compounds. In some embodiments of aspects provided herein, the OCM effluent comprises at least about 5% olefin and/or acetylene compounds. In some embodiments of aspects provided herein, the OCM effluent comprises at least about 10% olefin and/or acetylene compounds. In some embodiments of aspects provided herein, the at least one metal element is nickel. In some embodiments of aspects provided herein, the at least one metal element is part of a metal oxide.

[0016] An aspect of the present disclosure provides a method for preventing coke formation on a methanation catalyst in an oxidative coupling of methane (OCM) process, the method comprising (a) providing an OCM effluent comprising carbon monoxide (CO) and/or carbon dioxide (CO₂) and (b) using a methanation catalyst to perform a methanation reaction with the OCM effluent, wherein (i) hydrogen and/or water is added to the OCM effluent prior to (b), (ii) olefins and/or acetylene in the OCM effluent is hydrogenated prior to (b); and/or (iii) olefins and/or acetylene are separated and/or condensed from the OCM effluent prior to (b).

[0017] In some embodiments of aspects provided herein, (iii) is performed using absorption or adsorption. In some embodiments of aspects provided herein, the methanation reaction forms at least about 1000-fold more methane than coke. In some embodiments of aspects provided herein, the methanation reaction forms at least about 10000-fold more methane than coke. In some embodiments of aspects provided herein, the methanation reaction forms at least about 100000-fold more methane than coke. In some embodiments of aspects provided herein, the method further comprises any two of (i), (ii) and (iii). In some embodiments of aspects provided herein, the method further comprises all of (i), (ii) and (iii).

[0018] An aspect of the present disclosure provides an oxidative coupling of methane (OCM) system for production of olefins and power, comprising: (a) an OCM subsystem that (i) takes as input a feed stream comprising methane (CH_4) and a feed stream comprising an oxidizing agent, and (ii) generates from the methane and the oxidizing agent a product stream comprising C_{2+} compounds and heat; and (b) a power subsystem fluidically and/or thermally coupled to the OCM subsystem that converts the heat into electrical power.

[0019] In some embodiments of aspects provided herein, the oxidizing agent is O_2 . In some embodiments of aspects provided herein, the O_2 is provided by air. In some embodiments of aspects provided herein, the OCM subsystem comprises at least one OCM reactor. In some embodiments of aspects provided herein, the OCM subsystem comprises at least one post-bed cracking unit within the at least one OCM reactor or downstream of the at least one OCM reactor, which post-bed cracking unit is configured to convert at least a portion of alkanes in the product stream to alkenes. In some embodiments of aspects provided herein, the power subsystem is a gas turbine combined cycle (GTCC). In some embodiments of aspects provided herein, the system further comprises a steam generator for generating steam from the heat, which steam is converted to electrical power in the power subsystem. In some embodiments of aspects provided herein, the power subsystem comprises a gas turbine and un-reacted methane from the OCM subsystem is converted to electrical power using the gas turbine. In some embodiments of aspects provided herein, a ratio of production of C_{2+} alkenes and production of power can be varied by adjusting a composition of the feed stream. In some embodiments of aspects provided herein, a ratio of production of C_{2+} alkenes and production of power can be varied by adjusting an amount of C_{2+} alkanes fed into a post-bed cracking section of the OCM subsystem.

[0020] An aspect of the present disclosure provides a method for producing at least one C_{2+} alkene and power, comprising: (a) directing methane and an oxidizing agent into a reactor comprising a catalyst unit, wherein the catalyst unit comprises an oxidative coupling of methane (OCM) catalyst that facilitates an OCM reaction that produces C_{2+} alkene; (b) reacting the

methane and oxidizing agent with the aid of the OCM catalyst to generate at least one OCM product comprising at least one C_{2+} compound and heat; and (c) generating electrical power from the heat.

[0021] In some embodiments of aspects provided herein, the heat is converted to steam and the steam is converted to power in a steam turbine. In some embodiments of aspects provided herein, un-reacted methane from the reactor is converted to electrical power in a gas turbine. In some embodiments of aspects provided herein, the reactor comprises a cracking unit downstream of the catalyst unit, wherein the cracking unit generates C_{2+} alkene from C_{2+} alkane, and wherein the method further comprises; (d) providing at least one hydrocarbon-containing stream that is directed through the cracking unit, which hydrocarbon-containing stream comprises at least one C_{2+} alkane; and (e) in the cracking unit, cracking the at least one C_{2+} alkane to provide the at least one C_{2+} alkene in a product stream that is directed out of the reactor. In some embodiments of aspects provided herein, the hydrocarbon-containing stream comprises at least one OCM product. In some embodiments of aspects provided herein, the C_{2+} alkene produced from the at least one hydrocarbon-containing stream in the cracking unit is in addition to the C_{2+} alkene produced from the methane and the oxidizing agent in the reactor. In some embodiments of aspects provided herein, the amount of steam produced is varied or the amount of at least one hydrocarbon-containing stream that is directed through the cracking unit is varied to alter the amount of electrical power produced and the amount of C_{2+} alkene produced. In some embodiments of aspects provided herein, the OCM catalyst is a nanowire catalyst. In some embodiments of aspects provided herein, the oxidizing agent is O_2 . In some embodiments of aspects provided herein, the at least one C_{2+} alkane comprises a plurality of C_{2+} alkanes. In some embodiments of aspects provided herein, the cracking unit generates C_{2+} alkene from C_{2+} alkane with the aid of the heat generated in the OCM reaction. In some embodiments of aspects provided herein, the reactor is adiabatic.

[0022] An aspect of the present disclosure provides a method for producing hydrocarbon compounds including two or more carbon atoms (C_{2+} compounds), the method comprising: (a) performing an oxidative coupling of methane (OCM) reaction in an OCM reactor to produce an OCM effluent comprising carbon dioxide (CO_2), hydrogen (H_2), one or more C_{2+} compounds, and methane (CH_4); (b) separating the OCM effluent into (i) a first stream comprising at least some of the one or more C_{2+} compounds and (ii) a second stream comprising carbon monoxide (CO), CO_2 , H_2 , and CH_4 ; (c) methanating the second stream to produce a first OCM reactor feed comprising CH_4 formed from the H_2 and CO and/or CO_2 in the second stream; (d) methanating a third stream comprising CH_4 and H_2 to produce a second OCM reactor feed comprising CH_4 ,

which third stream is from an ethylene cracker; and (e) directing the first and second OCM reactor feeds to the OCM reactor.

[0023] In some embodiments of aspects provided herein, the second stream and the third stream are methanated in a single methanation reactor. In some embodiments of aspects provided herein, the method further comprises providing at least a portion of the first stream to the ethylene cracker. In some embodiments of aspects provided herein, the at least the portion of the first stream is provided to a gas compressor or a fractionation unit of the ethylene cracker. In some embodiments of aspects provided herein, the third stream is the overhead stream of a demethanizer unit of the ethylene cracker. In some embodiments of aspects provided herein, the separating in (b) is performed at least in part in a pressure swing adsorption (PSA) unit. In some embodiments of aspects provided herein, the separating in (b) is performed at least in part with a CO₂ removal system or a process gas dryer. In some embodiments of aspects provided herein, the OCM effluent is compressed prior to (b). In some embodiments of aspects provided herein, the method further comprises feeding oxygen (O₂) as an oxidizing agent to the OCM reactor, which O₂ takes part in the OCM reaction. In some embodiments of aspects provided herein, the OCM effluent comprises carbon monoxide (CO) that is converted into CH₄ in (c). In some embodiments of aspects provided herein, the OCM reaction further reacts CH₄ from natural gas to achieve additional ethylene production. In some embodiments of aspects provided herein, the third stream further comprises CH₄.

[0024] An aspect of the present disclosure provides an oxidative coupling of methane (OCM) system for production of hydrocarbon compounds including two or more carbon atoms (C₂₊ compounds), comprising: (a) an OCM subsystem that (i) takes as input a first feed stream comprising methane (CH₄) and a second feed stream comprising an oxidizing agent, and (ii) generates a product stream comprising C₂₊ compounds from the CH₄ and the oxidizing agent; (b) a separation subsystem fluidically coupled to the OCM subsystem that separates the product stream into (i) a first stream comprising C₂₊ compounds and (ii) a second stream comprising hydrogen (H₂) and carbon dioxide (CO₂) and/or carbon monoxide (CO); (c) a methanation subsystem fluidically coupled to the second stream and to the OCM subsystem, wherein the methanation subsystem converts H₂ and CO₂ and/or CO into CH₄; and (d) an ethylene cracker subsystem fluidically coupled to the methanation subsystem that provides CH₄, H₂, CO₂ and/or CO to the methanation subsystem.

[0025] In some embodiments of aspects provided herein, the methanation subsystem provides CH₄ to the OCM subsystem. In some embodiments of aspects provided herein, at least some of the additional H₂ is derived from a demethanizer of the ethylene cracker subsystem. In some

embodiments of aspects provided herein, the first stream is fluidically coupled to the ethylene cracker subsystem. In some embodiments of aspects provided herein, the first stream is fractionated in the ethylene cracker subsystem. In some embodiments of aspects provided herein, the separation subsystem comprises a pressure swing adsorption (PSA) unit. In some embodiments of aspects provided herein, the OCM subsystem reacts CH_4 from natural gas with the oxidizing agent in an OCM reaction. In some embodiments of aspects provided herein, the oxidizing agent comprises O_2 . In some embodiments of aspects provided herein, the O_2 is generated from air. In some embodiments of aspects provided herein, the OCM subsystem comprises at least one OCM reactor. In some embodiments of aspects provided herein, the OCM subsystem comprises at least one post-bed cracking unit within the at least one OCM reactor or downstream of the at least one OCM reactor, which post-bed cracking unit is configured to convert at least a portion of alkanes in the product stream to alkenes. In some embodiments of aspects provided herein, the reactor is adiabatic.

[0026] An aspect of the present disclosure provides a method for producing hydrocarbon compounds including two or more carbon atoms (C_{2+} compounds), the method comprising: (a) performing an oxidative coupling of methane (OCM) reaction in an OCM reactor to produce an OCM effluent stream comprising carbon dioxide (CO_2), hydrogen (H_2), one or more C_{2+} compounds, and methane (CH_4); (b) separating the OCM effluent stream into a first stream comprising at least some of the one or more C_{2+} compounds and a second stream comprising carbon monoxide (CO), CO_2 , H_2 , and CH_4 ; (c) methanating the second stream to produce a first methanated stream comprising CH_4 formed from the H_2 and CO and/or CO_2 in the second stream; (d) removing at least a portion of the first methanated stream; and (e) directing the portion of the first methanated stream into a natural gas pipeline.

[0027] In some embodiments of aspects provided herein, (e) comprises directing the portion of the first methanated stream into the natural gas pipeline in exchange for an item of value.

[0028] An aspect of the present disclosure provides a method for producing hydrocarbon compounds including two or more carbon atoms (C_{2+} compounds), the method comprising: (a) performing a natural gas liquids (NGL) extraction in an NGL extraction unit to produce an NGL stream comprising ethane, propane, and/or butane and a methane stream comprising methane; (b) directing the methane stream to an oxidative coupling of methane (OCM) reactor; and (c) performing an OCM reaction in the OCM reactor using the methane stream to produce an OCM effluent comprising carbon dioxide (CO_2), hydrogen (H_2), one or more C_{2+} compounds, and methane (CH_4).

[0029] An aspect of the present disclosure provides a method for producing hydrocarbon compounds including two or more carbon atoms (C_{2+} compounds), the method comprising: (a) performing an oxidative coupling of methane (OCM) reaction in an OCM reactor to produce an OCM effluent stream comprising carbon dioxide (CO_2), hydrogen (H_2), one or more C_{2+} compounds, and methane (CH_4); (b) separating the OCM effluent stream into a first stream comprising at least some of the one or more C_{2+} compounds and a second stream comprising carbon monoxide (CO), CO_2 , H_2 , and CH_4 ; (c) directing the second stream to a Fischer-Tropsch (F-T) reactor; (d) in the F-T reactor, performing an F-T reaction using the second stream to produce a first OCM reactor feed comprising CH_4 formed from the H_2 and CO in the second stream; and (e) directing the first OCM reactor feeds to the OCM reactor.

[0030] An aspect of the present disclosure provides a method for producing hydrocarbon compounds including two or more carbon atoms (C_{2+} compounds), the method comprising: (a) performing an oxidative coupling of methane (OCM) reaction in an OCM reactor to produce an OCM effluent stream comprising carbon dioxide (CO_2), hydrogen (H_2), one or more C_{2+} compounds, and methane (CH_4); (b) separating the OCM effluent stream into a first stream comprising at least some of the one or more C_{2+} compounds and a second stream comprising carbon monoxide (CO), CO_2 , H_2 , and CH_4 ; and (c) directing the OCM effluent stream to a heat recovery steam generator (HRSG) system; (d) with the HRSG system, transferring heat from the OCM effluent stream to a water stream to produce steam.

[0031] An aspect of the present disclosure provides a method for producing hydrocarbon compounds including two or more carbon atoms (C_{2+} compounds), the method comprising: (a) performing an oxidative coupling of methane (OCM) reaction in an OCM reactor to produce an OCM effluent stream comprising carbon dioxide (CO_2), hydrogen (H_2), one or more C_{2+} compounds, and methane (CH_4); (b) separating the OCM effluent stream into a first stream comprising at least some of the one or more C_{2+} compounds and a second stream comprising carbon monoxide (CO), CO_2 , H_2 , and CH_4 ; (c) directing the second stream and an air stream to a gas compressor, and burning at least a portion of the second stream and compressing the air stream to produce a compressed air stream; (d) separating the compressed air stream in an air separation unit (ASU) into a third stream comprising O_2 and a fourth stream comprising N_2 ; and (e) feeding the oxygen-rich stream to the OCM reactor.

[0032] An aspect of the present disclosure provides a method for producing hydrocarbon compounds including two or more carbon atoms (C_{2+} compounds), the method comprising: (a) performing an oxidative coupling of methane (OCM) reaction in an OCM reactor to produce an OCM effluent stream comprising carbon dioxide (CO_2), hydrogen (H_2), one or more C_{2+}

compounds, and methane (CH₄); (b) transferring heat from the OCM effluent stream in a first heat exchanger and a second heat exchanger downstream of the first heat exchanger with respect to a flow direction of the OCM effluent stream, thereby cooling the OCM effluent stream; (c) demethanizing the OCM effluent stream in a demethanizer, thereby producing an overhead stream comprising carbon dioxide (CO₂), hydrogen (H₂), and methane (CH₄) and a bottom stream comprising one or more C₂₊ compounds; (d) expanding the overhead stream, thereby cooling the overhead stream; (e) transferring heat to the overhead stream in the second heat exchanger and the first heat exchanger downstream of the second heat exchanger with respect to a flow direction of the overhead stream, thereby heating the overhead stream; and (f) feeding the overhead stream from the first heat exchanger into the OCM reactor.

[0033] An aspect of the present disclosure provides a method for producing hydrocarbon compounds including two or more carbon atoms (C₂₊ compounds), the method comprising: (a) performing an oxidative coupling of methane (OCM) reaction in an OCM reactor to produce an OCM effluent stream comprising carbon dioxide (CO₂), hydrogen (H₂), one or more C₂₊ compounds, and methane (CH₄); (b) transferring heat from the OCM effluent stream in a first heat exchanger and subsequently expanding the OCM effluent stream, thereby cooling the OCM effluent stream; (c) demethanizing the OCM effluent stream in a demethanizer, thereby producing an overhead stream comprising carbon dioxide (CO₂), hydrogen (H₂), and methane (CH₄) and a bottom stream comprising one or more C₂₊ compounds; (d) transferring heat to a first portion of the overhead stream in a second heat exchanger and the first heat exchanger downstream of the second heat exchanger with respect to a flow direction of the first portion of the overhead stream, thereby heating the first portion of the overhead stream; (e) compressing a second portion of the overhead stream and, in a phase separation unit, separating the second portion of the overhead stream into a liquid stream and a vapor stream; and (f) directing the liquid stream through the second heat exchanger and into the demethanizer.

[0034] In some embodiments of aspects provided herein, the method further comprises expanding the vapor stream to cool the vapor stream. In some embodiments of aspects provided herein, the method further comprises transferring heat to the vapor stream in the second heat exchanger and the first heat exchanger.

[0035] An aspect of the present disclosure provides a method for producing hydrocarbon compounds including two or more carbon atoms (C₂₊ compounds), the method comprising: (a) performing an oxidative coupling of methane (OCM) reaction in an OCM reactor to produce an OCM effluent stream comprising carbon dioxide (CO₂), hydrogen (H₂), one or more C₂₊ compounds, and methane (CH₄); (b) transferring heat from the OCM effluent stream in a first

heat exchanger and subsequently expanding the OCM effluent stream, thereby cooling the OCM effluent stream; (c) demethanizing the OCM effluent stream in a demethanizer, thereby producing an overhead stream comprising carbon dioxide (CO₂), hydrogen (H₂), and methane (CH₄) and a bottom stream comprising one or more C₂₊ compounds; (d) compressing a first portion of the overhead stream, thereby heating the first portion of the overhead stream, and subsequently in a second heat exchanger transferring heat from the first portion of the overhead stream, thereby cooling the first portion of the overhead stream; (e) in a phase separation unit, separating the first portion of the overhead stream into a liquid stream and a vapor stream; and (f) transferring heat from the liquid stream in a third heat exchanger and subsequently directing the liquid stream into the demethanizer.

[0036] In some embodiments of aspects provided herein, the method further comprises: expanding the vapor stream, thereby cooling the vapor stream; and transferring heat to the vapor stream in the third heat exchanger, the second heat exchanger, and/or the first heat exchanger, thereby heating the vapor stream. In some embodiments of aspects provided herein, the method further comprises: expanding a second portion of the overhead stream, thereby cooling the second portion of the overhead stream; and transferring heat to the second portion of the overhead stream in the third heat exchanger, the second heat exchanger, and/or the first heat exchanger, thereby heating the second portion of the overhead stream.

[0037] An aspect of the present disclosure provides a method for producing hydrocarbon compounds including two or more carbon atoms (C₂₊ compounds), the method comprising: (a) performing an oxidative coupling of methane (OCM) reaction in an OCM reactor to produce an OCM effluent stream comprising carbon dioxide (CO₂), hydrogen (H₂), one or more C₂₊ compounds, and methane (CH₄); (b) transferring heat from the OCM effluent stream in a first heat exchanger, thereby cooling the OCM effluent stream; (c) demethanizing the OCM effluent stream in a demethanizer, thereby producing an overhead stream comprising carbon dioxide (CO₂), hydrogen (H₂), and methane (CH₄) and a bottom stream comprising one or more C₂₊ compounds; (d) compressing a first portion of the overhead stream, thereby heating the first portion of the overhead stream, and subsequently transferring heat from the first portion of the overhead stream in a second heat exchanger, thereby cooling the first portion of the overhead stream; (e) in a first phase separation unit, separating the first portion of the overhead stream into a first liquid stream and a first vapor stream; (f) expanding the vapor stream, thereby cooling the first vapor stream and subsequently transferring heat to the first vapor stream in the second heat exchanger and/or the first heat exchanger, thereby heating the first vapor stream; and (g) sub-cooling and flashing the first liquid stream to produce a two-phase stream and, in a second phase

separation unit, separating the two-phase stream into a second liquid stream and a second vapor stream, and directing the second liquid stream to the demethanizer.

[0038] An aspect of the present disclosure provides a method for producing hydrocarbon compounds with two or more carbon atoms (C_{2+} compounds), the method comprising: (a) performing an oxidative coupling of methane (OCM) reaction in an OCM system comprising two or more OCM reactor stages to produce an OCM effluent stream comprising carbon dioxide (CO_2), hydrogen (H_2), one or more C_{2+} compounds, and methane (CH_4); (b) separating the OCM effluent into a first stream comprising at least some of the one or more C_{2+} compounds and a second stream comprising carbon monoxide (CO), CO_2 , H_2 , and CH_4 ; (c) methanating the second stream to produce a first OCM reactor feed comprising CH_4 formed from the H_2 and CO and/or CO_2 in the second stream; and (d) directing the first OCM reactor feed to the OCM reactor.

[0039] An aspect of the present disclosure provides a method for producing hydrocarbon compounds including two or more carbon atoms (C_{2+} compounds), the method comprising: (a) performing an oxidative coupling of methane (OCM) reaction in an OCM reactor using air as an oxidant to produce an OCM effluent stream comprising carbon dioxide (CO_2), hydrogen (H_2), one or more C_{2+} compounds, and methane (CH_4); (b) separating the OCM effluent stream into a first stream comprising at least some of the one or more C_{2+} compounds and a second stream comprising carbon monoxide (CO), CO_2 , H_2 , and CH_4 ; (c) methanating the second stream to produce an OCM reactor feed comprising CH_4 formed from the H_2 and CO and/or CO_2 in the second stream; and (d) directing the OCM reactor feed to the OCM reactor.

[0040] An aspect of the present disclosure provides a method for producing hydrocarbon compounds including two or more carbon atoms (C_{2+} compounds), the method comprising: (a) performing an oxidative coupling of methane (OCM) reaction in an OCM reactor using O_2 as an oxidant to produce an OCM effluent stream comprising carbon dioxide (CO_2), hydrogen (H_2), one or more C_{2+} compounds, and methane (CH_4); (b) separating the OCM effluent stream into a first stream comprising at least some of the one or more C_{2+} compounds and a second stream comprising carbon monoxide (CO), CO_2 , H_2 , and CH_4 ; (c) methanating the second stream to produce an OCM reactor feed comprising CH_4 formed from the H_2 and CO and/or CO_2 in the second stream; and (d) directing the OCM reactor feed to the OCM reactor.

[0041] In some embodiments of aspects provided herein, the OCM reactor feed comprises water.

[0042] An aspect of the present disclosure provides a method for producing hydrocarbon compounds including two or more carbon atoms (C_{2+} compounds), the method comprising: (a) performing an oxidative coupling of methane (OCM) reaction in an OCM reactor to produce an

OCM effluent stream comprising carbon dioxide (CO₂), hydrogen (H₂), one or more C₂₊ compounds, and methane (CH₄); (b) separating the OCM effluent stream into a first stream comprising at least some of the one or more C₂₊ compounds and a second stream comprising carbon monoxide (CO), CO₂, H₂, and CH₄; (c) separating the second stream in a pressure swing adsorption (PSA) unit to produce an OCM reactor feed comprising CH₄ and a third stream comprising H₂ and CO and/or CO₂; and (d) directing the OCM reactor feed to the OCM reactor.

[0043] An aspect of the present disclosure provides a method for producing hydrocarbon compounds including two or more carbon atoms (C₂₊ compounds), the method comprising: (a) performing an oxidative coupling of methane (OCM) reaction in an OCM reactor to produce an OCM effluent stream comprising carbon dioxide (CO₂), hydrogen (H₂), one or more C₂₊ compounds, and methane (CH₄); (b) separating the OCM effluent stream into a first stream comprising at least some of the one or more C₂₊ compounds and a second stream comprising carbon monoxide (CO), CO₂, H₂, and CH₄; (c) separating the second stream in a membrane separation unit to produce an OCM reactor feed comprising CH₄ and a third stream comprising H₂ and CO and/or CO₂; and (d) directing the OCM reactor feed to the OCM reactor.

[0044] An aspect of the present disclosure provides a method for producing hydrocarbon compounds including two or more carbon atoms (C₂₊ compounds), the method comprising: (a) performing an oxidative coupling of methane (OCM) reaction in an OCM reactor to produce an OCM effluent stream comprising carbon dioxide (CO₂), hydrogen (H₂), one or more C₂₊ compounds, and methane (CH₄); (b) separating the OCM effluent stream in a pressure swing adsorption (PSA) unit into a first stream comprising at least some of the one or more C₂₊ compounds and CH₄ and a second stream comprising carbon monoxide (CO), CO₂, and H₂; (c) separating the first stream in a demethanizer unit to produce an OCM reactor feed comprising CH₄ and a third stream comprising the at least some of the one or more C₂₊ compounds; and (d) directing the OCM reactor feed to the OCM reactor.

[0045] An aspect of the present disclosure provides a method for producing hydrocarbon compounds including two or more carbon atoms (C₂₊ compounds), the method comprising: (a) performing an oxidative coupling of methane (OCM) reaction in an OCM reactor to produce an OCM effluent stream comprising carbon dioxide (CO₂), hydrogen (H₂), one or more C₂₊ compounds, and methane (CH₄); (b) separating the OCM effluent stream in a pressure swing adsorption (PSA) unit into a first stream comprising CH₄ and a second stream comprising at least some of the one or more C₂₊ compounds, carbon monoxide (CO), CO₂, and H₂; (c) separating the second stream to produce a third stream comprising the at least some of the one or more C₂₊

compounds and a fourth stream comprising carbon monoxide (CO), CO₂, and H₂; and (d) directing the first stream to the OCM reactor.

[0046] Additional aspects and advantages of the present disclosure will become readily apparent to those skilled in this art from the following detailed description, wherein only illustrative embodiments of the present disclosure are shown and described. As will be realized, the present disclosure is capable of other and different embodiments, and its several details are capable of modifications in various obvious respects, all without departing from the disclosure.

Accordingly, the drawings and description are to be regarded as illustrative in nature, and not as restrictive.

INCORPORATION BY REFERENCE

[0047] All publications, patents, and patent applications mentioned in this specification are herein incorporated by reference to the same extent as if each individual publication, patent, or patent application was specifically and individually indicated to be incorporated by reference.

BRIEF DESCRIPTION OF THE DRAWINGS

[0048] The novel features of the invention are set forth with particularity in the appended claims. A better understanding of the features and advantages of the present invention will be obtained by reference to the following detailed description that sets forth illustrative embodiments, in which the principles of the invention are utilized, and the accompanying drawings or figures (also "FIG." and "FIGs." herein), of which:

[0049] **FIG. 1** is a block flow diagram of a system that is configured to generate olefins, such as ethylene;

[0050] **FIGs. 2A** and **2B** show an oxidative coupling of methane (OCM) system for small scale olefin production;

[0051] **FIG. 3** is a process flow diagram of a system that comprises a hydrogenation unit and a deethanizer unit, which can be employed for small scale and world scale olefin production;

[0052] **FIG. 4** is process flow diagram of a sulfur removal system for small scale olefin production;

[0053] **FIG. 5** shows a process flow diagram of a sulfur removal system for world scale olefin production;

[0054] **FIGs. 6A** and **6B** show methanation systems that can be used with systems of the present disclosure;

[0055] **FIG. 7** shows an example of a methanation system for OCM;

[0056] **FIGs. 8A** and **8B** show an OCM system for world scale olefin production;

- [0057] FIG. 9 shows a separation system that may be employed for use with systems and methods of the present disclosure;
- [0058] FIG. 10 shows another separation system that may be employed for use with systems and methods of the present disclosure;
- [0059] FIG. 11 shows another separation system that may be employed for use with systems and methods of the present disclosure;
- [0060] FIG. 12 shows another separation system that may be employed for use with systems and methods of the present disclosure;
- [0061] FIG. 13 shows a heat recovery steam generator system;
- [0062] FIG. 14 shows an example of an OCM system that produces power;
- [0063] FIG. 15 shows an example of an OCM process with fresh ethane feed and no sales gas export;
- [0064] FIG. 16 shows an example of an ethane skimmer implementation of OCM;
- [0065] FIG. 17 shows a system comprising an existing natural gas liquids (NGL) / gas processing plant that has been retrofitted with an oxidative coupling of methane (OCM) system for small scale and world scale olefin production (e.g., ethylene production);
- [0066] FIG. 18 shows an example of integration of OCM with an ethylene plant.
- [0067] FIG. 19 shows an example of integration of an OCM process with a naphtha cracker;
- [0068] FIG. 20 shows a computer system that is programmed or otherwise configured to regulate OCM reactions;
- [0069] FIG. 21 shows a schematic overview of an implementation of OCM;
- [0070] FIG. 22 shows a photograph of a formed OCM catalyst;
- [0071] FIG. 23 shows a scanning electron micrograph (SEM) of an OCM catalyst;
- [0072] FIG. 24 shows another SEM of an OCM catalyst;
- [0073] FIG. 25 shows an example of a temperature profile of an OCM reactor;
- [0074] FIG. 26 shows a process flow diagram of a portion of an implementation of OCM;
- [0075] FIG. 27 shows a process flow diagram of a portion of an implementation of OCM;
- [0076] FIG. 28 shows a process flow diagram of a portion of an implementation of OCM;
- [0077] FIG. 29 shows a process flow diagram of a portion of an implementation of OCM;
- [0078] FIG. 30 shows a process flow diagram of a portion of an implementation of OCM; and
- [0079] FIG. 31 shows a process flow diagram of a portion of an implementation of OCM.

DETAILED DESCRIPTION

[0080] While various embodiments of the invention have been shown and described herein, it will be obvious to those skilled in the art that such embodiments are provided by way of example

only. Numerous variations, changes, and substitutions may occur to those skilled in the art without departing from the invention. It should be understood that various alternatives to the embodiments of the invention described herein may be employed.

[0081] The term “higher hydrocarbon,” as used herein, generally refers to a higher molecular weight and/or higher chain hydrocarbon. A higher hydrocarbon can have a higher molecular weight and/or carbon content that is higher or larger relative to starting material in a given process (e.g., OCM or ETL). A higher hydrocarbon can be a higher molecular weight and/or chain hydrocarbon product that is generated in an OCM or ETL process. For example, ethylene is a higher hydrocarbon product relative to methane in an OCM process. As another example, a C₃₊ hydrocarbon is a higher hydrocarbon relative to ethylene in an ETL process. As another example, a C₅₊ hydrocarbon is a higher hydrocarbon relative to ethylene in an ETL process. In some cases, a higher hydrocarbon is a higher molecular weight hydrocarbon.

[0082] The term “OCM process,” as used herein, generally refers to a process that employs or substantially employs an oxidative coupling of methane (OCM) reaction. An OCM reaction can include the oxidation of methane to a higher hydrocarbon and water, and involves an exothermic reaction. In an OCM reaction, methane can be partially oxidized and coupled to form one or more C₂₊ compounds, such as ethylene. In an example, an OCM reaction is $2\text{CH}_4 + \text{O}_2 \rightarrow \text{C}_2\text{H}_4 + 2\text{H}_2\text{O}$. An OCM reaction can yield C₂₊ compounds. An OCM reaction can be facilitated by a catalyst, such as a heterogeneous catalyst. Additional by-products of OCM reactions can include CO, CO₂, H₂, as well as hydrocarbons, such as, for example, ethane, propane, propene, butane, butene, and the like.

[0083] The term “non-OCM process,” as used herein, generally refers to a process that does not employ or substantially employ an oxidative coupling of methane reaction. Examples of processes that may be non-OCM processes include non-OCM hydrocarbon processes, such as, for example, non-OCM processes employed in hydrocarbon processing in oil refineries, a natural gas liquids separations processes, steam cracking of ethane, steam cracking or naphtha, Fischer-Tropsch processes, and the like.

[0084] The terms “C₂₊” and “C₂₊ compound,” as used herein, generally refer to a compound comprising two or more carbon atoms. For example, C₂₊ compounds include, without limitation, alkanes, alkenes, alkynes and aromatics containing two or more carbon atoms. C₂₊ compounds can include aldehydes, ketones, esters and carboxylic acids. Examples of C₂₊ compounds include ethane, ethene, acetylene, propane, propene, butane, and butene.

[0085] The term “non-C₂₊ impurities,” as used herein, generally refers to material that does not include C₂₊ compounds. Examples of non-C₂₊ impurities, which may be found in certain OCM

reaction product streams, include nitrogen (N₂), oxygen (O₂), water (H₂O), argon (Ar), hydrogen (H₂), carbon monoxide (CO), carbon dioxide (CO₂) and methane (CH₄).

[0086] The term “small scale,” as used herein, generally refers to a system that generates less than or equal to about 250 kilotons per annum (KTA) of a given product, such as an olefin (e.g., ethylene).

[0087] The term “world scale,” as used herein, generally refers to a system that generates greater than about 250 KTA of a given product, such as an olefin (e.g., ethylene). In some examples, a world scale olefin system generates at least about 1000, 1100, 1200, 1300, 1400, 1500, or 1600 KTA of an olefin.

[0088] The term “item of value,” as used herein, generally refers to money, credit, a good or commodity (e.g., hydrocarbon). An item of value can be traded for another item of value.

OCM Processes

[0089] In an OCM process, methane (CH₄) reacts with an oxidizing agent over a catalyst bed to generate C₂₊ compounds. For example, methane can react with oxygen over a suitable catalyst to generate ethylene, e.g., $2 \text{CH}_4 + \text{O}_2 \rightarrow \text{C}_2\text{H}_4 + 2 \text{H}_2\text{O}$ (See, e.g., Zhang, Q., *Journal of Natural Gas Chem.*, **12**:81, 2003; Olah, G. “Hydrocarbon Chemistry”, Ed. 2, John Wiley & Sons (2003)). This reaction is exothermic ($\Delta H = -67 \text{kcal/mole}$) and has typically been shown to occur at very high temperatures (e.g., $>450^\circ\text{C}$ or $>700^\circ\text{C}$). Non-selective reactions that can occur include (a) $\text{CH}_4 + 2\text{O}_2 \rightarrow \text{CO}_2 + 2 \text{H}_2\text{O}$ and (b) $\text{CH}_4 + 1/2 \text{O}_2 \rightarrow \text{CO} + 2 \text{H}_2$. These non-selective reactions are also exothermic, with reaction heats of -891 kJ/mol and -36 kJ/mol respectively. The conversion of methane to CO_x products is undesirable due to both heat management and carbon efficiency concerns.

[0090] Experimental evidence suggests that free radical chemistry is involved. (Lunsford, *J. Chem. Soc., Chem. Comm.*, 1991; H. Lunsford, *Angew. Chem., Int. Ed. Engl.*, **34**:970, 1995). In the reaction, methane (CH₄) is activated on the catalyst surface, forming methyl radicals which then couples in the gas phase to form ethane (C₂H₆), followed by dehydrogenation to ethylene (C₂H₄). The OCM reaction pathway can have a heterogeneous/ homogeneous mechanism, which involves free radical chemistry. Experimental evidence has shown that an oxygen active site on the catalyst activates the methane, removes a single hydrogen atom and creates a methyl radical. Methyl radicals react in the gas phase to produce ethane, which is either oxidatively or non-oxidatively dehydrogenated to ethylene. The main reactions in this pathway can be as follows: (a) $\text{CH}_4 + \text{O}^- \rightarrow \text{CH}_3^* + \text{OH}^-$; (b) $2 \text{CH}_3^* \rightarrow \text{C}_2\text{H}_6$; (c) $\text{C}_2\text{H}_6 + \text{O}^- \rightarrow \text{C}_2\text{H}_4 + \text{H}_2\text{O}$. In some cases, to improve the reaction yield, ethane can be introduced downstream of the OCM catalyst bed and thermally dehydrogenated via the following reaction: $\text{C}_2\text{H}_6 \rightarrow \text{C}_2\text{H}_4 + \text{H}_2$. This

reaction is endothermic ($\Delta H = -144$ kJ/mol), which can utilize the exothermic reaction heat produced during methane conversion. Combining these two reactions in one vessel can increase thermal efficiency while simplifying the process.

[0091] Several catalysts have shown activity for OCM, including various forms of iron oxide, V_2O_5 , MoO_3 , Co_3O_4 , Pt-Rh, Li/ZrO₂, Ag-Au, Au/Co₃O₄, Co/Mn, CeO₂, MgO, La₂O₃, Mn₃O₄, Na₂WO₄, MnO, ZnO, and combinations thereof, on various supports. A number of doping elements have also proven to be useful in combination with the above catalysts.

[0092] Since the OCM reaction was first reported over thirty years ago, it has been the target of intense scientific and commercial interest, but the fundamental limitations of the conventional approach to C-H bond activation appear to limit the yield of this attractive reaction under practical operating conditions. Specifically, numerous publications from industrial and academic labs have consistently demonstrated characteristic performance of high selectivity at low conversion of methane, or low selectivity at high conversion (J.A. Labinger, *Cat. Lett.*, **1**:371, 1988). Limited by this conversion/selectivity threshold, no OCM catalyst has been able to exceed 20-25% combined C₂ yield (*i.e.*, ethane and ethylene), and more importantly, all such reported yields operate at extremely high temperatures (> 800°C). Novel catalysts and processes have been described for use in performing OCM in the production of ethylene from methane at substantially more practicable temperatures, pressures and catalyst activities. These are described in U.S. Patent Publication Nos. 2012/0041246, 2013/0023079, 2013/165728, 2014/0012053 and 2014/0018589, the full disclosures of each of which are incorporated herein by reference in its entirety for all purposes.

[0093] An OCM reactor can include a catalyst that facilitates an OCM process. The catalyst may include a compound including at least one of an alkali metal, an alkaline earth metal, a transition metal, and a rare-earth metal. The catalyst may be in the form of a honeycomb, packed bed, or fluidized bed. In some embodiments, at least a portion of the OCM catalyst in at least a portion of the OCM reactor can include one or more OCM catalysts and/or nanostructure-based OCM catalyst compositions, forms and formulations described in, for example, U.S. Patent Publication Nos. 2012/0041246, 2013/0023709, 2013/0158322, 2013/0165728, 2014/0181877 and 2014/0274671, each of which is entirely incorporated herein by reference. Using one or more nanostructure-based OCM catalysts within the OCM reactor, the selectivity of the catalyst in converting methane to desirable C₂₊ compounds can be about 10% or greater; about 20% or greater; about 30% or greater; about 40% or greater; about 50% or greater; about 60% or greater; about 65% or greater; about 70% or greater; about 75% or greater; about 80% or greater; or about 90% or greater.

[0094] In some cases, the selectivity of an OCM process in converting methane to desirable C₂₊ compounds is from about 20% to about 90%. In some cases, the selectivity of an OCM process in converting methane to desirable C₂₊ compounds is from about 30% to about 90%. In some cases, the selectivity of an OCM process in converting methane to desirable C₂₊ compounds is from about 40% to about 90%. In some cases, the selectivity of an OCM process in converting methane to desirable C₂₊ compounds is from about 50% to about 90%. In some cases, the selectivity of an OCM process in converting methane to desirable C₂₊ compounds is from about 60% to about 90%. In some cases, the selectivity of an OCM process in converting methane to desirable C₂₊ compounds is from about 70% to about 90%. In some cases, the selectivity of an OCM process in converting methane to desirable C₂₊ compounds is from about 80% to about 90%. The selectivity of an OCM process in converting methane to desirable C₂₊ compounds can be about 10% or greater; about 20% or greater; about 30% or greater; about 40% or greater; about 50% or greater; about 60% or greater; about 65% or greater; about 70% or greater; about 75% or greater; about 80% or greater; or about 90% or greater.

[0095] An OCM process can be characterized by a methane conversion fraction. For example, from about 5% to about 50% of methane in an OCM process feed stream can be converted to higher hydrocarbon products. In some cases, about 5%, 10%, 15%, 20%, 25%, 30%, 35%, 40%, 45%, or 50% of methane in an OCM process feed stream is converted to higher hydrocarbon products. In some cases, at least about 5%, 10%, 15%, 20%, 25%, 30%, 35%, 40%, 45%, or 50% of methane in an OCM process feed stream is converted to higher hydrocarbon products. In some cases, at most about 5%, 10%, 15%, 20%, 25%, 30%, 35%, 40%, 45%, or 50% of methane in an OCM process feed stream is converted to higher hydrocarbon products.

[0096] An OCM reactor can be sized, shaped, configured, and/or selected based upon the need to dissipate the heat generated by the OCM reaction. In some embodiments, multiple, tubular, fixed bed reactors can be arranged in parallel to facilitate heat removal. At least a portion of the heat generated within the OCM reactor can be recovered, for example the heat can be used to generate high temperature and/or pressure steam. Where co-located with processes requiring a heat input, at least a portion of the heat generated within the OCM reactor may be transferred, for example, using a heat transfer fluid, to the co-located processes. Where no additional use exists for the heat generated within the OCM reactor, the heat can be released to the environment, for example, using a cooling tower or similar evaporative cooling device. In some embodiments, an adiabatic fixed bed reactor system can be used and the subsequent heat can be utilized directly to convert or crack alkanes into olefins. In some embodiments, a fluidized bed reactor system can be utilized. OCM reactor systems useful in the context of the present invention may include

those described in, for example, U.S. Patent Application No. 13/900,898 (filed May 23, 2013), which is incorporated herein by reference in its entirety for all purposes.

[0097] The methane feedstock for an OCM reactor can be provided from various sources, such as non-OCM processes. In an example, methane is provided through natural gas, such as methane generated in a natural gas liquids (NGL) system.

[0098] Methane can be combined with a recycle stream from downstream separation units prior to or during introduction into an OCM reactor. In the OCM reactor, methane can catalytically react with an oxidizing agent to yield C₂₊ compounds. The oxidizing agent can be oxygen (O₂), which may be provided by way of air or enriched air. Oxygen can be extracted from air, for example, in a cryogenic air separation unit.

[0099] To carry out an OCM reaction in conjunction with some catalytic systems, the methane and oxygen containing gases generally need to be brought up to appropriate reaction temperatures, e.g., typically in excess of 450°C for some catalytic OCM processes, before being introduced to the catalyst, in order to allow initiation of the OCM reaction. Once that reaction begins or “lights off,” then the heat of the reaction is typically sufficient to maintain the reactor temperature at appropriate levels. Additionally, these processes may operate at a pressure above atmospheric pressure, such as in the range of about 1 to 30 bars (absolute).

[00100] In some cases, the oxidizing agent and/or methane are pre-conditioned prior to, or during, the OCM process. The reactant gases can be pre-conditioned prior to their introduction into a catalytic reactor or reactor bed, in a safe and efficient manner. Such pre-conditioning can include (i) mixing of reactant streams, such as a methane-containing stream and a stream of an oxidizing agent (e.g., oxygen) in an OCM reactor or prior to directing the streams to the OCM reactor, (ii) heating or pre-heating the methane-containing stream and/or the stream of the oxidizing agent using, for example, heat from the OCM reactor, or (iii) a combination of mixing and pre-heating. Such pre-conditioning can minimize, if not eliminate auto-ignition of methane and the oxidizing agent. Systems and methods for pre-conditioning reactant gases are described in, for example, U.S. Patent Application Serial No. 14/553,795, filed November 25, 2014, which is entirely incorporated herein by reference.

[00101] A wide set of competitive reactions can occur simultaneously or substantially simultaneously with the OCM reaction, including total combustion of both methane and other partial oxidation products. An OCM process can yield C₂₊ compounds as well as non-C₂₊ impurities. The C₂₊ compounds can include a variety of hydrocarbons, such as hydrocarbons with saturated or unsaturated carbon-carbon bonds. Saturated hydrocarbons can include alkanes, such as ethane, propane, butane, pentane and hexane. Unsaturated hydrocarbons may be more

suitable for use in downstream non-OCM processes, such as the manufacture of polymeric materials (e.g., polyethylene). Accordingly, at least some, all or substantially all of the alkanes in the C₂₊ compounds may be converted to compounds with unsaturated moieties, such as alkenes, alkynes, alkoxides, ketones, including aromatic variants thereof.

[00102] Once formed, C₂₊ compounds can be subjected to further processing to generate desired or otherwise predetermined chemicals. In some situations, the alkane components of the C₂₊ compounds are subjected to cracking in an OCM reactor or a reactor downstream of the OCM reactor to yield other compounds, such as alkenes (or olefins). See, e.g., U.S. Patent Application Serial No. 14/553,795, filed November 25, 2014, which is entirely incorporated herein by reference.

[00103] The OCM effluent can be cooled after the conversion to ethylene has taken place. The cooling can take place within a portion of the OCM reactor and/or downstream of the OCM reactor (e.g., using at least about 1, 2, 3, 4, 5 or more heat exchangers). In some cases, a heat exchanger is a heat recovery steam generator (HRSG). Cooling the OCM effluent suitably rapidly and to a suitably low temperature can prevent undesirable reactions from occurring with the OCM effluent, including, but not limited to the formation of coke or other by-products.

[00104] In some embodiments, the OCM effluent is cooled to a target temperature of equal to or less than about 700 °C, equal to or less than about 650 °C, equal to or less than about 600 °C, equal to or less than about 550 °C, equal to or less than about 500 °C, equal to or less than about 450 °C, equal to or less than about 400 °C, equal to or less than about 350 °C, equal to or less than about 300 °C, equal to or less than about 250 °C, or equal to or less than about 200 °C. In some cases, the OCM effluent is cooled to the target temperature within about 1 second, within about 900 milliseconds (ms), within about 800 ms, within about 700 ms, within about 600 ms, within about 500 ms, within about 400 ms, within about 300 ms, within about 200 ms, within about 100 ms, within about 80 ms, within about 60 ms, within about 40 ms, or within about 20 ms of the production of the desired or otherwise predetermined concentration of ethylene in the OCM reaction.

[00105] In some situations, an OCM system generates ethylene that can be subjected to further processing to generate different hydrocarbons with the aid of conversion processes (or systems). Such a process can be part of an ethylene to liquids (ETL) process flow comprising one or more OCM reactors, separations units, and one or more conversion processes for generating higher molecular weight hydrocarbons. The conversion processes can be integrated in a switchable or selectable manner in which at least a portion or all of the ethylene containing product can be selectively directed to 1, 2, 3, 4, 5, 6, 7, 8, 9, 10, or more different process paths

to yield as many different hydrocarbon products. An example OCM and ETL (collectively "OCM-ETL" herein) is provided in U.S. Patent Publication No. 2014/0171707, filed on December 6, 2013, which is entirely incorporated herein by reference.

OCM Processes for Producing Olefins

[00106] An aspect of the present disclosure provides OCM processes that are configured to generate olefins (or alkenes), such as ethylene, propylene (or propene), butylenes (or butenes), etc. An OCM process can be a standalone process or can be integrated in a non-OCM process, such as a natural gas liquids (NGL or NGLs) or gas processing system.

[00107] Reference will now be made to the figures, wherein like numerals refer to like parts throughout. It will be appreciated that the figures and features therein are not necessarily drawn to scale. In the figures, the direction of fluid flow between units is indicated by arrows. Fluid may be directed from one unit to another with the aid of valves and a fluid flow system. In some examples, a fluid flow system can include compressors and/or pumps, as well as a control system for regulating fluid flow, as described elsewhere herein.

[00108] **FIG. 1** is a block flow diagram of a system **100** that is configured to generate olefins, such as ethylene. The system **100** can be a small scale or world scale system. The system **100** comprises an OCM sub-system **101** that can include one or more OCM units in series and/or parallel. The OCM sub-system **101** can include one or more post-bed cracking (PBC) units for generating olefins (e.g., ethylene) from alkanes (e.g., ethane and/ or propane). A PBC unit can be disposed downstream of an OCM unit. The OCM unit and PBC unit can be situated in separate reactor, or included in the same reactor (e.g., a packed bed for OCM disposed upstream of a PBC unit in the same reactor). In some cases, an integrated OCM unit and PBC unit may be collectively referred to as an OCM reactor.

[00109] The OCM sub-system **101** can accept ethane and an oxidizing agent (e.g., O₂). In the illustrated example, the OCM sub-system **101** accepts ethane from ethane stream **102** and oxygen (O₂) from oxygen stream **103**. Ethane can be injected into the OCM sub-system **101** at a PBC unit of the OCM sub-system **101**. Oxygen can be provided by way of air or provided from an oxygen generation unit, such as a cryogenic unit that accepts air and generates individual O₂ and N₂ streams, or by O₂ pipeline. The OCM sub-system **101** also accepts methane from C₁ recycle stream **104** and ethane from C₂ recycle stream **105**.

[00110] In an OCM unit of the OCM sub-system **101**, methane can be catalytically reacted with oxygen in an OCM process to generate an OCM effluent stream **106** comprising C₂₊ compounds and non-C₂₊ impurities. The OCM effluent stream **106** can be directed to a PBC unit of the OCM sub-system **101** to convert one or more alkanes in the OCM effluent stream **106** to

alkenes. Next, the OCM effluent stream **106** can be directed to a process gas compressor (PGC) unit **107**. Natural gas (NG) is directed along an NG feed **108** to a sulfur removal unit **109**, which can remove sulfur-containing chemicals from the NG feed **108** to yield a sulfur-free methane feed **124** to the PGC unit **107**. As an alternative, the sulfur removal unit **109** can be excluded if the concentration of Sulfur in the incoming natural gas feed stream is very low and acceptable for the OCM process. As another alternative, the methane feed **124** can be provided from other sources that may not be natural gas. In some cases, for example if the natural gas feed has a considerable quantity of hydrogen, it can be routed to the methanation unit. From the PGC unit **107**, the OCM effluent can be directed to CO₂ removal unit **110**, which can remove CO₂ from the OCM effluent. At least a portion of the removed CO₂ can be directed to a methanation unit **111** along a CO₂ stream **112**. At least a portion of the removed CO₂ can be directed along CO₂ stream **113** for other users, such as, for example, storage or purged from the CO₂ removal unit **110**. In some cases, the CO₂ removal system can comprise a pressure swing adsorption (PSA) unit; in other cases, the CO₂ removal system can be based on any other membrane separation process. The effluent from the CO₂ removal unit can be treated to remove water. The water removal system can be a molecular sieve dryer, or a series of dryers (not shown in the figure).

[00111] Next, the OCM effluent can be directed from the CO₂ removal unit **110** to a demethanizer (also “de-methanizer” herein) unit **114**, which can separate methane from higher molecular weight hydrocarbons (e.g., acetylene, ethane and ethylene). The separated (or recovered) methane can be directed to the methanation unit **111** along a C₁ recycle stream **115**. Alternatively, or in addition to, the separated methane can be directed to the OCM sub-system **101**. A purge stream **123** can be directed out of the demethanizer unit **114**, which is a portion of stream **115**. The purge stream can contain methane and inert gas, such as, e.g., N₂, He or Ar. The purge flow rate may be sufficient such that the inert gas will not accumulate in the system. The purge stream may be required to remove inert gas(es) that are built-up in the recycle loop.

[00112] The methanation unit **111** can generate methane from CO, CO₂ and H₂. Methane generated in the methanation unit **111** can be directed to the OCM sub-system **101** along C₁ recycle stream 104. The methanation unit **111** can be as described elsewhere herein.

[00113] In some examples, the demethanizer unit **114** includes one or more distillations columns in series and/or parallel. A serial configuration can enable the separation of different components. A parallel configuration can enable separation of a fluid stream of greater volumetric flow rate. In an example, the demethanizer unit **114** comprises a distillation column and is configured to separate methane from C₂₊ compounds in the OCM effluent stream. The demethanizer unit **114** can be as described elsewhere herein.

[00114] Higher molecular weight hydrocarbons separated from methane in the demethanizer unit **114** can be directed to an acetylene conversion unit **116** along stream **117**. The acetylene conversion unit **116** can react acetylene (C_2H_2) in the OCM effluent with H_2 to generate ethylene. The acetylene conversion unit **116** in some cases can react other alkenes with H_2 to generate alkanes, such as ethane. The acetylene conversion unit **116** can be a hydrogenation reactor. The OCM effluent stream can then be directed from the acetylene conversion unit **116** to a deethanizer (also “de-ethanizer” herein) unit **118** along stream **119**. The deethanizer unit **118** can separate C_2 compounds (e.g., ethane and ethylene) from C_{3+} compounds (e.g., propane and propylene). Separated C_{3+} compounds can leave the deethanizer unit **118** along stream **120**. C_2 compounds from the deethanizer unit **118** can be directed to a C_2 splitter **121**, which can separate ethane from ethylene. The C_2 splitter **121** can be a distillation column. Recovered ethylene can be directed along stream **122** and employed for downstream use.

[00115] OCM effluent can be characterized by a particular ethane-to-ethylene ratio or range of ratios. For example, OCM effluent can have an ethane-to-ethylene-ratio from about 3:1 to about 1:20. OCM effluent can have an ethane-to-ethylene ratio of about 3:1, 2:1, 1:1, 1:2, 1:3, 1:4, 1:5, 1:6, 1:7, 1:8, 1:9, 1:10, 1:11, 1:12, 1:13, 1:14, 1:15, 1:16, 1:17, 1:18, 1:19, or 1:20.

[00116] OCM effluent can be characterized by a particular ratio or range of ratios of hydrocarbon compounds with three or more carbon atoms (“ C_{3+} compounds”) to C_2 compounds. For example, OCM effluent can have a C_{3+} compounds-to- C_2 compounds ratio from about 0 to about 1:3. OCM effluent can have a C_{3+} compounds-to- C_2 compounds ratio of about 0, 1:1000, 1:100, 1:90, 1:80, 1:70, 1:60, 1:50, 1:40, 1:30, 1:20, 1:19, 1:18, 1:17, 1:16, 1:15, 1:14, 1:13, 1:12, 1:11, 1:10, 1:9, 1:8, 1:7, 1:6, 1:5, 1:4, or 1:3.

[00117] OCM effluent can be characterized by a particular acetylene-to-ethylene ratio or range of ratios. For example, OCM effluent can have an acetylene-to-ethylene ratio from about 0 to about 1:1. OCM effluent can have an acetylene-to-ethylene ratio of about 0, 1:1000, 1:100, 1:90, 1:80, 1:70, 1:60, 1:50, 1:40, 1:30, 1:20, 1:19, 1:18, 1:17, 1:16, 1:15, 1:14, 1:13, 1:12, 1:11, 1:10, 1:9, 1:8, 1:7, 1:6, 1:5, 1:4, 1:3, 1:2, or 1:1.

[00118] OCM effluent can be characterized by a particular CO-to- CO_2 ratio or range of ratios. For example, OCM effluent can have a CO-to- CO_2 ratio from about 0 to about 2:1. OCM effluent can have a CO-to- CO_2 ratio of about 0, 1:1000, 1:100, 1:90, 1:80, 1:70, 1:60, 1:50, 1:40, 1:30, 1:20, 1:19, 1:18, 1:17, 1:16, 1:15, 1:14, 1:13, 1:12, 1:11, 1:10, 1:9, 1:8, 1:7, 1:6, 1:5, 1:4, 1:3, 1:2, 1:1, or 2:1.

[00119] Systems, methods, and processes of the present disclosure, such as those for OCM-ETL, operate on feedstocks with particular ethane-to-methane ratios. For example, a

system feedstock can have an ethane-to-methane ratio from about 0 to about 1:3. A system feedstock can have an ethane-to-methane ratio of about 0, 1:1000, 1:100, 1:90, 1:80, 1:70, 1:60, 1:50, 1:40, 1:30, 1:20, 1:19, 1:18, 1:17, 1:16, 1:15, 1:14, 1:13, 1:12, 1:11, 1:10, 1:9, 1:8, 1:7, 1:6, 1:5, 1:4, or 1:3.

[00120] The systems of the present disclosure, such as the systems of **FIGs. 1-2**, can be suited for the production of any olefin, such as, for example, ethylene. Thus, the systems above and elsewhere herein are not limited to ethylene but may be configured to generate other olefins, such as propylene, butenes, pentene, or other alkenes.

[00121] Post-bed cracking (PBC) units that may be suitable for use with systems of the present disclosure, such as the systems of **FIGs. 1-2**, are described in, for example, U.S. Patent Application Serial No. 14/553,795, filed November 25, 2014, which is entirely incorporated herein by reference.

[00122] The systems of **FIGs. 1** and **17** may employ different unit operations for small scale and world scale olefin production (e.g., ethylene production). The present disclosure provides non-limiting example unit operations and process flows for various units that may be employed for use with the systems of **FIGs. 1** and **17**.

Subsystems in an OCM Unit

[00123] **FIGs. 2-4** show various sub-systems that may be suitable for use in a system that is configured for the production of ethylene or other olefins at small scale. Any suitable gas processing technology (e.g., recycle split gas (RSV) or other gas processing technologies may be implemented in the extraction unit to separate methane from NGLs or C₂₊ components with an economic recovery that may be at least about 70%, 80%, 90%, 91%, 92%, 93%, 94%, 95%, 96%, 97%, 98%, or 99%. **FIG. 2A** shows an OCM reactor **201** that is configured to generate C₂₊ compounds from oxygen (O₂) and methane, which can be directed into the OCM reactor **201** along an oxygen stream **202** and a methane stream **203**, respectively. Ethane can be directed into the OCM reactor **201** along an ethane recycle stream **227**. The streams **202**, **203** and **227** can each be pre-conditioned prior to injection into the OCM reactor **201**. Such pre-conditioning can include pre-heating and/or pre-mixing. For example, the methane stream **203** can be mixed with the oxygen stream **202** prior to injection into the OCM reactor **201**.

[00124] The OCM reactor **201** can include an OCM unit upstream of a PBC unit. The OCM unit can include one or more catalysts for catalyzing an OCM reaction using oxygen and methane directed into the OCM reactor **201** along streams **202** and **203**, respectively. The OCM reactor **201** can generate an OCM effluent comprising C₂₊ compounds and non-C₂₊ impurities. The OCM effluent can be directed along an OCM effluent stream **204** from the OCM reactor **201**

to a plurality of heat exchangers, shown in the figure as a single heat recovery block **205**, which transfers heat from the OCM effluent stream **204** to the methane stream **203** to pre-heat the methane stream **203**. The OCM effluent stream **204** can be directed to a separator **210**, which can remove water from the OCM effluent stream **204** and provide a water stream **211** comprising water and an OCM effluent stream **212** comprising C_{2+} compounds and non- C_{2+} impurities. The concentration of water in the stream **212** may be substantially reduced in relation to the concentration of water in the OCM effluent stream **204**.

[00125] With continued reference to **FIG. 2A**, CO and/or CO_2 in a recycle stream **206** from downstream processes (see below) are directed into a methanation system **207** and used to generate methane in a methanation process, as described elsewhere herein. Methane generated in the methanation system **207** is directed along the methane stream **203** into the OCM reactor **201**. Recycle methane (C_1) is directed along C_1 recycle stream **208** into the methanation system **207** and combined with the methane formed in the methanation system **207**. The C_1 recycle stream can be pre-heated in a heat exchanger prior to introduction into the methanation system **207**.

[00126] With reference to **FIG. 2B**, the OCM effluent stream **212** is directed into the compression and treatment section. The OCM effluent **212** is routed to a quench tower **213** where the OCM effluent gases are quenched with a cooling medium and any process condensates are condensed and removed. The cooled OCM effluent is then fed to the compressor unit **214**, which can comprise of a single or multiple stages of compression. The compressor unit **214** can also comprise inter-stage coolers and separator vessels which raise the pressure of the OCM effluent stream **212** (e.g., by a factor of from about 2.5:1 to 4:1) and remove water from the OCM effluent stream **212**. The condensate streams from the separator vessels from **214** are routed along **215** as the net condensate removed from the unit. The pressurized OCM effluent stream **216** (which includes C_{2+} compounds) can be mixed with methane from stream **228** (e.g., natural gas stream) and subsequently directed to a CO_2 removal system **217** for removing CO_2 from the OCM effluent stream **216**. The CO_2 removal system **217** can be an amine system, a membrane separation system or a caustic based wash system. The absorption system **217** comprises an absorption unit **218**, a regenerator **219** and a scrubber **220**. The absorption unit **218** can employ an aqueous solution of various alkylamines (also “amines” herein) to scrub CO_2 and H_2S from the OCM effluent stream **216**. Examples of amines include, without limitation, diethanolamine, monoethanolamine, methyldiethanolamine and diisopropanolamine. The resultant “rich” amine is then routed into the regenerator **219** (e.g., a stripper with a reboiler) to produce regenerated or “lean” amine that is recycled for reuse in the absorption unit **218**. The

separated CO₂ can be purged **221** or recycled **222** (e.g., to the methanation system **207** in stream **206**).

[00127] The absorption unit **218** generates an OCM effluent stream that can have a low CO₂ content, which is directed to the scrubber **220**. The scrubber removes additional CO₂ and entrained solvents from the OCM effluent stream, using, for example, a sodium hydroxide stream that is directed through the scrubber **220** in a counter flow configuration. The OCM effluent stream **223** is then directed from the scrubber **220** to a separator **224**, which removes water from the OCM effluent stream **223**. The removed water is directed along stream **215**. The OCM effluent stream is then directed to dryers **225** and subsequently directed along stream **226**. The dryers **225** can remove water from the OCM effluent stream. The OCM effluent stream **223** may be cooled in a heat exchanger upon heat transfer to a C₁ recycle stream, for example.

[00128] The system of **FIG. 2A** and **2B** may be employed for use with other systems of the present disclosure. For example, the absorption system **217** of **FIG. 2B** may be employed for use as the amine unit **110** of **FIG. 1**. The series of compressors **213**, heat exchangers and separators of **FIG. 2B** may be employed for use as the PGC **107** of **FIG. 1**.

[00129] **FIG. 3** is a process flow diagram of a system **300** that can be used to generate ethane and ethylene from acetylene (C₂H₂) and subsequently separate ethane from ethylene. The sub-system **300** may be suitable for the small scale production of ethylene. The system **300** can be employed for use as the acetylene reactor **116**, deethanizer **118** and C₂ splitter **121** of **FIG. 1**. The system **300** comprises a hydrogenation reactor unit **301**, a first separation unit **302** and a second separation unit **303**. The first separation unit **302** and second separation unit **303** can be distillation columns. The hydrogenation reactor unit **301** accepts a stream **304** comprising H₂ and a stream **305** comprising C₂₊ compounds, which can include acetylene, and converts any acetylene in the stream **305** to ethane and/or ethylene. The C₂₊ compounds are then directed in stream **306** to the first separation unit **302**, which separates C₃₊ compounds (e.g., propane, propylene, butane, butene, etc.) from C₂ compounds (ethane and/or ethylene) in the C₂₊ compounds. The first separation unit **302** may be referred to as a deethanizer. The C₃₊ compounds are directed along stream **307** and employed for downstream use. The C₂ compounds are directed to the second separation unit **303**, which separates ethane from ethylene. The second separation unit **303** may be referred to as a C₂ splitter. Ethane from the second separation unit **303** is directed along stream **308** and ethylene is directed along stream **309**. Ethane can be recycled, such as recycled to an OCM reactor. In some examples, the ethane is recycled to a PBC unit of an OCM reactor.

[00130] The stream **304** may be directed to a pressure swing adsorption (PSA) unit (not shown) that is configured to separate H₂ from N₂. H₂ from the stream **304** may then be directed to the hydrogenation reactor **301**. The stream **304** may be provided by a separation system, such as the system **1100** of **FIG. 11**. In situations in which a PSA is employed, the system **300** may be suitable for use in world scale olefin production. For small scale olefin production, the PSA may be precluded.

[00131] The acetylene hydrogenation reaction can be practiced over a palladium-based catalyst, such as those used to convert acetylene to ethylene in conventional steam cracking (e.g., the PRICAT™ series including models PD 301/1, PD 308/4, PD 308/6, PD 508/1, PD 408/5, PD 408/7 and PD 608/1, which may be commercially available as tablets or spheres supported on alumina). In some cases, the acetylene hydrogenation catalyst is a doped or modified version of a commercially available catalyst.

[00132] However, in some cases, applying an acetylene hydrogenation catalyst to the OCM process that has been developed or optimized for another process (e.g., steam cracking separations and purification processes) can result in operational issues and/or non-optimized performance. For example, in steam cracking, the acetylene conversion reactor can either be located on the front end (prior to cryogenic separations) or back end (after cryogenic separations) of the process. In steam cracking, these differences in running front end and back end typically have to do with the ratio of hydrogen to acetylene present, the ethylene to acetylene ratio, and the non-ethylene olefin (e.g., butadiene) to acetylene ratio. All of these factors can impact the catalyst selectivity for forming ethylene from acetylene, the lifetime and regeneration of the catalyst, green oil formation, specific process conditions for the reactor, and additional hydrogen required for the reaction. These factors are also different between steam cracking versus OCM processes, therefore, provided herein is an acetylene hydrogenation catalyst that is designed to be used in an OCM process.

[00133] In OCM implementations, the chemical components going into the acetylene reactor can be different than for steam cracking. For example, OCM effluent can include carbon monoxide and hydrogen. Carbon monoxide can be undesirable because it can compete with the acetylene for the active sites on the hydrogenation catalyst and lead to lower activity of the catalyst (e.g., by occupying those active sites). Hydrogen can be desirable because it is needed for the hydrogenation reaction, however that hydrogen is present in the OCM effluent in a certain ratio and adjusting that ratio can be difficult. Therefore, the catalyst described herein provides the desired outlet concentrations of acetylene, desired selectivity of acetylene conversion to ethylene, desired conversion of acetylene, desired lifetime and desired activity in

OCM effluent gas. As used herein, "OCM effluent gas" generally refers to the effluent taken directly from an OCM reactor, or having first undergone any number of further unit operations such as changing the temperature, the pressure, or performing separations on the OCM reactor effluent. The OCM effluent gas can have CO, H₂ and butadiene.

[00134] In some embodiments, the catalyst decreases the acetylene concentration below about 100 parts per million (ppm), below about 80 ppm, below about 60 ppm, below about 40 ppm, below about 20 ppm, below about 10 ppm, below about 5 ppm, below about 3 ppm, below about 2 ppm, below about 1 ppm, below about 0.5 ppm, below about 0.3 ppm, below about 0.1 ppm, or below about 0.05 ppm.

[00135] The concentration of acetylene can be reached in the presence of carbon monoxide (CO). In some embodiments, the feed stream entering the acetylene hydrogenation reactor contains at least about 10%, at least about 9%, at least about 8%, at least about 7%, at least about 6%, at least about 5%, at least about 4%, at least about 3%, at least about 2%, or at least about 1% carbon monoxide.

[00136] When used in an OCM process, the acetylene hydrogenation catalyst can have a lifetime of at least about 6 months, at least about 1 year, at least about 2 years, at least about 3 years, at least about 4 years, at least about 5 years, at least about 6 years, at least about 7 years, at least about 8 years, at least about 9 years, or at least about 10 years.

[00137] **FIG. 4** is a process flow diagram of a sulfur removal system **400**, which can be employed for use in removing sulfur-containing compounds from a gas stream. The sulfur removal system **400** can be employed for use as the sulfur removal system **109** of **FIG. 1**, for example. The system **400** can be employed for use in a system that is configured to generate small scale ethylene. The system **400** comprises a separation unit **401** for removing water from a natural gas stream **402**. Water is removed along stream **403**. The natural gas stream with decreased water content is directed along stream **404** to a heat exchanger **405**, another optional heat exchanger **406** and an absorption unit **408**. The heat exchangers **405** and **406** raise the temperature of the natural gas stream. The absorption unit removes H₂S from the natural gas stream. This can provide a stream **409** comprising methane and having a substantially low sulfur and H₂O content. In some examples, the stream **409** is directed to an OCM reactor. As an alternative, or in addition to, the stream **409** can be directed to a natural gas pipeline.

[00138] In certain cases, depending on the concentration of sulfur compounds in the natural gas feed stream, the sulfur removal unit can comprise one or more hydrodesulfurization (hydrotreater) reactors to convert the sulfur compounds to H₂S, which is then subsequently removed by an amine system.

[00139] FIG. 5 shows a sulfur removal unit comprising a separation unit 501, a hydrogen feed stream 502, a natural gas stream 503, a flare header 504, a methane-containing stream 505, a heat exchanger 506, a heat recovery steam generator (HRSG) system 507, a hydro treating unit 508, an absorption unit 509, and a product stream 510. The separation unit 501 is configured to remove water from the stream 503. Water removed from the stream 503 is directed to the flare header 504. The hydro treating unit 508 generates H₂S from H₂ provided by the stream 502 and sulfur in the stream 503. Any sulfur-containing compounds in the stream 503 and generated in the hydro treating unit 508 can be removed in the absorption unit 509. The resulting product stream 510 can include methane and substantially low concentrations of sulfur-containing compounds, such as H₂S. In some examples, the product stream 510 can be directed to an OCM reactor or a natural gas pipeline.

[00140] The HRSG system 507 is an energy recovery heat exchanger that recovers heat from the stream 505. The HRSG system 507 can produce steam that can be used in a process (cogeneration) or used to drive a steam turbine (combined cycle). The HRSG unit 507 can be as described herein.

Methanation Systems

[00141] Oxidative coupling of methane (OCM) can convert natural gas to ethylene and other longer hydrocarbon molecules via reaction of methane with oxygen. Given the operating conditions of OCM, side reactions can include reforming and combustion, which can lead to the presence of significant amounts of H₂, CO and CO₂ in the OCM effluent stream. H₂ content in the effluent stream can range between about 5% and about 15%, between about 1% and about 15%, between about 5% and about 10%, or between about 1% and about 5% (molar basis). The content of CO and CO₂ can each range between about 1% and about 5%, between about 1% and about 3%, or between about 3% and about 5% (molar basis). In some cases, the ethylene and all the other longer hydrocarbon molecules contained in the effluent stream are separated and purified to yield the final products of the process. This can leave an effluent stream containing the unconverted methane, hydrogen, CO and CO₂ and several other compounds, including low amounts of the product themselves depending on their recovery rates.

[00142] In some cases, this effluent stream is recycled to the OCM reactor. However, if CO and H₂ are recycled to the OCM reactor along with methane, they can react with oxygen to produce CO₂ and H₂O, causing various negative consequences to the process including, but not limited to: (a) an increase of the natural gas feed consumption (e.g., because a larger portion of it may result in CO₂ generation instead of product generation); (b) a decrease of the OCM per-pass methane conversion (e.g., because a portion of the allowable adiabatic temperature increase may

be exploited by the H₂ and CO combustion reactions instead of the OCM reactions); and an increase of the oxygen consumption (e.g., because some of the oxygen feed may react with CO and H₂ instead of methane).

[00143] The effluent stream can be exported to a natural gas pipeline (e.g., to be sold as sales gas into the natural gas infrastructure). Given that specifications can be in place for natural gas pipelines, the concentrations of CO, CO₂ and H₂ in the effluent can need to be reduced to meet the pipeline requirements. The effluent stream may also be used as a feedstock for certain processes that may require lower concentrations of H₂, CO and CO₂.

[00144] Therefore, it can be desirable to reduce the concentration of H₂, CO and CO₂ in the OCM effluent stream, upstream or downstream of the separation and recovery of the final products. This can be accomplished using methanation systems and/or by separating H₂ and CO from the effluent stream (e.g., using cryogenic separations or adsorption processes). The disclosure also includes separating CO₂ from the effluent stream using CO₂ removal processes, such as chemical or physical absorption or adsorption or membranes. However, these separation processes can require significant capital investments and can consume considerable amounts of energy, in some cases making an OCM-based process less economically attractive.

[00145] The present disclosure also provides systems and methods for reducing CO, CO₂ and H₂ concentration in a methane stream. Such compounds can be reacted to form methane in a methanation reaction.

[00146] An aspect of the present disclosure provides a methanation system that can be employed to reduce the concentration of CO, CO₂ and H₂ in a given stream, such as an OCM product stream. This can advantageously minimize the concentration of CO, CO₂ and H₂ in any stream that may be ultimately recycled to an OCM reactor. The methanation system can be employed for use with any system of the present disclosure, such as an OCM-ETL system described herein.

[00147] In a methanation system, CO reacts with H₂ to yield methane via $\text{CO} + 3 \text{H}_2 \rightarrow \text{CH}_4 + \text{H}_2\text{O}$. In the methanation system, CO₂ can react with H₂ to yield methane via $\text{CO}_2 + 4 \text{H}_2 \rightarrow \text{CH}_4 + 2 \text{H}_2\text{O}$. Such processes are exothermic ($\Delta H = -206 \text{ kJ/mol}$ and -178 kJ/mol , respectively) and generate heat that may be used as heat input to other process units, such as heating an OCM reactor of a PBC reactor, or pre-heating reactants, such as methane and/or an oxidizing agent (e.g., O₂) prior to an OCM reaction. The methanation reaction can take place in two or more reactors in series, in some cases with intercooling. In some situations, a methanation reactor can be implemented in tandem with an OCM reactor to increase carbon efficiency.

[00148] In some cases, to limit the heat release per unit of flow of reactants, methanation can be conducted on streams that contain CO, CO₂, H₂ and a suitable carrier gas. The carrier gas can include an inert gas, such as, e.g., N₂, He or Ar, or an alkane (e.g., methane, ethane, propane and/or butane). The carrier gas can add thermal heat capacity and significantly reduce the adiabatic temperature increase resulting from the methanation reactions.

[00149] In some examples, methane and higher carbon alkanes (e.g., ethane, propane and butane) and nitrogen are employed as carrier gases in a methanation process. These molecules can be present in an OCM process, such as in an OCM product stream comprising C₂₊ compounds. Downstream separation units, such as a cryogenic separation unit, can be configured to produce a stream that contains any (or none) of these compounds in combination with CO and H₂. This stream can then be directed to the methanation system.

[00150] A methanation system can include one or more methanation reactors and heat exchangers. CO, CO₂ and H₂ can be added along various streams to the one or more methanation reactors. A compressor can be used to increase the CO₂ stream pressure up to the methanation operating pressure, which can be from about 2 bar (absolute) to 60 bar, or 3 bar to 30 bar. CO₂ can be added to the inlet of the system in order to create an excess of CO₂ compared to the amount stoichiometrically required to consume all the available H₂. This is done in order to minimize H₂ recycled to OCM.

[00151] Given the exothermicity of the methanation reactions, a methanation system can include various methanation reactors for performing methanation. In some cases, a methanation reactor is an adiabatic reactor, such as an adiabatic fixed bed reactor. The adiabatic reactor can be in one stage or multiple stages, depending, for example, on the concentration of CO, CO₂ and H₂ in the feed stream to the methanation system. If multiple stages are used, inter-stage cooling can be performed by either heat exchangers (e.g., a stage effluent can be cooled against the feed stream or any other colder stream available in the plant, such as boiler feed water) or quenching via cold shots, i.e. the feed stream is divided into multiple streams, with one stream being directed to the first stage while each of the other feed streams being mixed with each stage effluent for cooling purposes. As an alternative, or in addition to, a methanation reactor can be an isothermal reactor. In such a case, reaction heat can be removed by the isothermal reactor by, for example, generating steam, which can enable a higher concentration of CO, CO₂ and H₂ to be used with the isothermal reactor. Apart from adiabatic and isothermal reactors, other types of reactors may be used for methanation, such as fluidized bed reactors.

[00152] **FIG. 6A** shows an example methanation system **600**. The system **600** may be used in OCM systems that are for small scale or world scale production of ethylene or other

olefins. The system **600** comprises a first reactor **601**, second reactor **602** and a heat exchanger **603**. The first reactor **601** and second reactor **602** can be adiabatic reactors. During use, a recycle stream **604** comprising methane, CO and H₂ (e.g., from a cryogenic separation unit) is directed to the heat exchanger **603**. In an example, the recycle stream **604** comprises between about 65% and 90% (molar basis) methane, between about 5% and 15% H₂, between 1% and 5% CO, between about 0% and 0.5% ethylene, and the balance inert gases (e.g., N₂, Ar and He). The recycle stream **604** can have a temperature from about 20 °C to 40 °C, or 20°C to 30°C, and a pressure from about 2 bar to 60 bar (absolute), or 3 bar to 30 bar. The recycle stream **604** can be generated by a separation unit downstream of an OCM reactor, such as a cryogenic separation unit.

[00153] In the heat exchanger **603**, the temperature of the recycle stream **604** is increased to about 100°C to 400°C, or 200°C to 300°C. The heated recycle stream **604** is then directed to the first reactor **601**. In the first reactor **601**, CO and H₂ in the recycle stream **604** react to yield methane. This reaction can progress until all of the H₂ is depleted and/or a temperature approach to equilibrium of about 0 to 30°C, or 0 to 15°C is achieved. The methanation reaction in the first reactor **601** can result in an adiabatic temperature increase of about 20°C to 300°C, or 50°C to 150°C.

[00154] Next, products from the first reactor, including methane and unreacted CO and/or H₂, can be directed along a first product stream to the heat exchanger **603**, where they are cooled to a temperature of about 100°C to 400°C, or 200°C to 300°C. In the heat exchanger **603**, heat from the first product stream **603** is removed and directed to the recycle stream **604**, prior to the recycle stream **604** being directed to the first reactor **601**.

[00155] Next, a portion of the heated first product stream is mixed with a CO₂ stream **605** to yield a mixed stream that is directed to the second reactor **602**. The CO₂ stream **605** can be generated by a separation unit downstream of an OCM reactor, such as a cryogenic separation unit. This can be the same separation unit that generated the recycle stream **604**.

[00156] In the second reactor **602**, CO and CO₂ react with H₂ to yield a second product stream **606** comprising methane. The reaction(s) in the second reactor **602** can progress until substantially all of the H₂ is depleted and/or a temperature approach to equilibrium of about 0 to 30°C, or 0 to 15°C is achieved. The proportions of CO, CO₂ and H₂ in the mixed stream can be selected such that the second product stream **606** is substantially depleted in CO and H₂.

[00157] The first reactor **601** and the second reactor **602** can be two catalytic stages in the same reactor vessel or can be arranged as two separate vessels. The first reactor **601** and second reactor **602** can each include a catalyst, such as a catalyst comprising one or more of ruthenium,

cobalt, nickel and iron. The first reactor **601** and second reactor **602** can be fluidized bed or packed bed reactors. Further, although the system **600** comprises two reactors **601** and **602**, the system **600** can include any number of reactors in series and/or in parallel, such as at least 1, 2, 3, 4, 5, 6, 7, 8, 9, 10, 20, 30, 40, or 50 reactors.

[00158] Although the CO₂ stream **605** is shown to be directed to the second reactor **602** and not the first reactor **601**, in an alternative configuration, at least a portion or the entire CO₂ stream **605** can be directed to the first reactor **601**. The proportions of CO, CO₂ and H₂ can be selected such that the methanation product stream is substantially depleted in CO and H₂.

[00159] Methane generated in the system **600** can be employed for various uses. In an example, at least a portion of the methane can be recycled to an OCM reactor (e.g., as part of an OCM-ETL system) to generate C₂₊ compounds, including alkenes (e.g., ethylene). As an alternative, or in addition to, at least a portion of the methane can be directed to a non-OCM process, such as a natural gas stream of a natural gas plant. As another alternative, or in addition to, at least a portion of the methane can be directed to end users, such as along a natural gas pipeline.

[00160] **FIG. 6B** is a process flow diagram of an example of a methanation system that can be employed to generate ethylene. The system of **FIG. 6B** can be used in other systems of the present disclosure, such as the system **100** of **FIG. 1**. The system comprises compressors **607** and **608**, separation units **609** and **610**, and methanation reactors **611** and **612**. The separation units **609** and **610** can be quench towers, which may separate water from a stream comprising CO and/or CO₂. During use, a stream **613** comprising CO and/or CO₂ is directed to the compressor **607** and subsequently the separator unit **609**. In stream **614**, CO and/or CO₂ along with H₂ are directed to the methanation reactor **611** and are reacted to form methane, which, along with any excess CO, CO₂ and H₂, is subsequently directed to the methanation reactor **612**, where CO and/or CO₂ provided in stream **615** is reacted with H₂ to form additional methane. The methane generated in the methanation reactors **611** and **612** is directed along stream **616**. The methane in stream **616** can be, for example, recycled to an OCM reactor.

[00161] Use of methanation systems with OCM systems of the present disclosure can reduce the quantity CO and/or CO₂ that are directed to the environment, which may advantageously decrease overall greenhouse emissions from such systems. In some examples, using a methanation system, the emission of CO and/or CO₂ from an OCM system can be reduced by at least about 0.01%, 0.1%, 1%, 2%, 3%, 4%, 5%, 6%, 7%, 8%, 9%, 10%, 20%, 30%, 40%, or 50%.

[00162] The methanation reaction can be practiced over a nickel-based catalyst, such as those used to produce SNG (Substitute Natural Gas or Synthetic Natural Gas) from syngas or used to purify streams containing CO and CO₂ (e.g., to remove CO and CO₂ present in the make-up feed to an ammonia synthesis unit). Examples of such catalysts include the KATALCO™ series (including models 11-4, 11-4R, 11-4M and 11-4MR) that may include nickel supported on refractory oxides; the HTC series (including NI 500 RP 1.2) having nickel supported on alumina; and Type 146 having ruthenium supported on alumina. Additional methanation catalysts can include models PK-7R and METH-134. The methanation catalyst can be tableted or an extruded. The shapes of such catalysts can be, for example, cylindrical, spherical, or ring structures, for or partial shapes and/or combinations of shapes thereof. In some cases, ring structures are advantageous due to their reduced pressure drop across the reactor bed relative to cylindrical and spherical commercial forms. In some cases, the methanation catalyst is a doped or modified version of a commercially available catalyst.

[00163] In some cases, merely applying a methanation catalyst to the OCM process that has been developed or optimized for another process (e.g., SNG production or gas purification) can result in operational problems and/or non-optimal performance, including carbon formation (or coking) over the methanation catalyst. Coking can lead to de-activation of the catalyst and, eventually, to loss of conversion through the methanation reactor, thus making the methanation process ineffective, severely limiting the performances of the overall OCM-based process and, possibly, preventing the final products from achieving the required specifications.

[00164] The selectivity and/or conversion produced by an existing and/or commercially available methanation catalyst at a given process condition (e.g., gas-hourly space velocity, molar composition, temperature, pressure) may not be ideal for OCM implementations. For example, ammonia plants can have between about 100 ppm and 1% CO with a molar excess of H₂ (e.g., 2, 5, 10, 50, 100-fold or more excess) that drives equilibrium in favor of complete methanation. Methanation systems in ammonia plants have a small temperature difference between inlet and outlet of the adiabatic methanation reactor (e.g., 20 to 30 °C) and can be sized for catalyst lifetime. SNG production does not have a vast molar excess of H₂ in some cases. Methanation in SNG processes can have an inlet versus outlet temperature difference of greater than 100 °C and be performed in multiple stages. Furthermore, the purpose of methanation can be different for OCM. Ammonia and SNG processes typically perform methanation primarily to eliminate CO and/or CO₂ (although H₂ can also be eliminated or substantially reduced in concentration), while methanation is performed in OCM processes primarily to eliminate H₂ (although CO and/or CO₂ can also be eliminated or substantially reduced in concentration).

[00165] A methanation catalyst and/or catalytic process is described herein that can prevent or reduce carbon formation in the methanation reactor or other operational inefficiencies. The catalyst and/or catalytic process is achieved through any combination of: (a) removing chemical species that can contribute to coke formation from the methanation inlet feed; (b) introducing chemical species into the methanation feed that eliminate or reduce the rate of coke formation; and (c) using the methanation catalyst described herein that reduces or eliminates coke formation and/or is designed to operate at the process conditions of OCM effluent or OCM process streams (e.g., gas-hourly space velocity, molar composition, temperature, pressure).

[00166] In some instances, the species present in the OCM effluent stream that can lead to carbon formation in the methanation reactor are removed or reduced in concentration using a separations or reactive process. The typical operating conditions of a methanation reactor can be at a pressure between about 3 bar and about 50 bar and a temperature between about 150 °C and about 400 °C. Any hydrocarbon species containing carbon-carbon double or triple bonds may be sufficiently reactive to form carbon deposits (i.e., coke). Examples of such species are acetylene, all olefins and aromatic compounds. Removal or significant reduction of these species can be achieved via different methods including, but not limited to: (a) hydrogenation (i.e., reaction of these species with the hydrogen present in the effluent stream itself to produce alkanes) over suitable catalysts prior to the methanation reactor; (b) condensation and separation of these species from methane prior to the methanation reactor; (c) absorption or adsorption of these species; (d) by utilizing suitable membranes; or (d) any combination thereof.

[00167] In some embodiments, species are introduced into the methanation inlet stream that eliminate or reduce the rate of carbon formation. Molecular species that can create a reducing atmosphere can be used to counteract an oxidation reaction and can therefore reduce the rate of carbon formation. Hydrogen and water are examples of these particular compounds and can be added to the OCM effluent stream prior to methanation to increase their concentration in the methanation reactor.

[00168] An aspect of the present disclosure provides a methanation catalyst for an OCM process. Coke formation is typically the product of surface driven reactions. Therefore, the methanation catalyst for OCM alters the local electronic environment around the active site of the catalyst. This can be done by changing the elemental composition (for example via post-impregnation doping, or creating a new mixed metal of nickel and another transition metal), morphology and structure (for example via synthesizing the metal in a non-bulk form factor). Examples of such syntheses include; nanowires of the same material, nanoparticles coated on a support, and vapor deposition of the active material on a support material. Additional

modifications to the surface may result from post synthetic processing steps, such as etching of the surface, oxidizing and reducing the metal to create a different surface reconstruction, calcination steps under different atmospheres (e.g., oxidizing or reducing), heating to achieve different crystal phases, and inducing defect formation. The end result of the modifications of the methanation catalyst is specifically designed to minimize carbon (coke) formation, while still effectively at conducting the methanation reactions.

[00169] The methanation process and/or methanation catalyst can operate with OCM product gas, either directly or after one or more heat exchangers or separation operations. For example, the methanation feed stream can have the following composition on a molar basis: CH₄ between about 65% and about 90%; H₂ between about 5% and about 15%; CO between about 1% and about 5% (molar basis); C₂H₄ between about 0% and about 0.5%; C₂H₂ between about 0% and about 0.1%; and the balance inert gases such as N₂, Ar and He. The methanation feed stream typically has a temperature close to ambient temperature and a pressure ranging between about 3 and about 50 bar.

[00170] The methanation reaction can produce water and/or have water in the methanation effluent. In some cases, it is desirable to remove this water prior to recycling the methanation effluent to the OCM reactor. This can be accomplished by lowering the temperature of the methanation effluent or performing any separation procedure that removes the water. In some embodiments, at least about 70%, at least about 80%, at least about 70%, at least about 90%, at least about 95%, or at least about 99% of the water is removed from the methanation effluent prior to the OCM reactor. Removing the water can increase the lifetime and/or performance of the OCM catalyst.

[00171] A methanation process can be implemented in an OCM-based process using adiabatic reactors. In an example, the process does not require a methanation catalyst specially designed or optimized for OCM. In this example, an OCM-based process is designed to produce ethylene from natural gas. In this case the product and recovery section of the OCM plant (e.g., a cryogenic unit) can be designed to separate ethylene and all other hydrocarbons from methane, CO and H₂ in the OCM effluent. The mixed stream that contains methane, CO and H₂ can be fed to the methanation section.

[00172] **FIG. 7** shows an example of a methanation system for OCM. The methanation feed stream **700** is first sent to a first heat exchanger **705** where its temperature is increased to the methanation reactor inlet temperature, typically between 150 °C and 300 °C. Steam **710** is injected immediately downstream of the first heat exchanger to increase water concentration in the methanation feed stream. Then the heated stream is fed to a first adiabatic reactor **715** where

ethylene, acetylene and any other hydrocarbon that presents carbon-carbon double or triple bonds are hydrogenated via reaction with the H₂ present in the stream.

[00173] The effluent from the first reactor **715** is then fed to a second reactor **720**, where CO reacts with H₂ until a certain approach to equilibrium is achieved, typically 0 °C – 15 °C to equilibrium. The adiabatic temperature increase that results from CO methanation depends on the exact composition of the feed stream and is typically in the 50 °C – 150 °C range.

[00174] The second reactor **720** effluent is then sent to the first heat exchanger **705** and a second heat exchanger **725** where it is cooled down to a temperature below water condensation. The stream is then fed to a phase separator **730** where the condensed water **735** is separated from the vapors **740** in order to minimize the water concentration in the vapors. It can be important to remove water at this stage to optimize the conditions for the second methanation stage (water is a product of the methanation reaction and is no longer needed in the second stage because all carbon forming species have been either removed or converted at this point).

[00175] The vapor stream **740** is fed to a third heat exchanger **745** where it is heated up to the temperature required at the inlet of the third adiabatic reactor **750**, which is the second methanation stage, typically operated at between about 150 °C and about 300 °C. Additional CO₂ **755** produced in the process is mixed with effluent from the second reactor **720** and fed to the third reactor **750**. CO and CO₂ react with H₂ in the third reactor **750** until a 0 °C – 15 °C temperature approach to equilibrium is reached. Typically the amount of CO₂ that is added to the second reactor effluent is more than what may be stoichiometrically required to consume all H₂, to push the equilibrium towards CO and H₂ complete depletion.

[00176] The liquid stream from the phase separator **735** is re-injected into the methanation feed stream alongside the steam. Alternatively, it can be first vaporized and then re-injected, or it can be sent to a water treatment system for water recovery and purification.

[00177] The three reactors, **715**, **720** and **750** or any combination of them can be physically situated in the same vessel or can be arranged in separate individual vessels. A portion or even all of the CO₂ addition may be performed at the inlet of **715** or **720**, depending on the type of catalyst used in the two reactors.

OCM System Configurations

[00178] An OCM reactor system can comprise a single reactor or multiple reactors in series and/or in parallel. For example, the OCM reactor system includes at least 2, 3, 4, or 5 OCM reactors in series. As another example, the OCM reactor system includes at least 2, 3, 4, or 5 OCM reactors in parallel. As another example, the OCM reactor includes two OCM reactors in parallel, both of which are downstream of another OCM reactor. In some cases, an

OCM reactor system can comprise two reactors, three reactors, or four reactors in series. In certain embodiments, the above mentioned number of reactors can be connected in parallel, or a combination thereof (e.g., mixed series and parallel). In addition, either one or more of the OCM reactor can contain a post-bed cracking (PBC) section as a part of the OCM reactor.

[00179] The OCM reaction is highly exothermic and the heat produced can be used to generate steam. A heat recovery system can be designed so as to cool down OCM reactor effluent to a temperature of less than or equal to about 600 °C, 500 °C, 400 °C, 300 °C or 200 °C, or a temperature between any two of these values (e.g., between 200 °C and 600 °C, or 300 °C and 500 °C), and to use that heat as process heat within the OCM unit, to heat boiler feed water (BFW) or steam, or for other processes.

[00180] FIGs. 5, 8, and 13 show various sub-systems that may be suitable for use in a system that is configured for the production of ethylene at world scale. With reference to FIG. 8A, a system 800 comprises a first OCM unit 801 and second OCM unit 802. The OCM units 801 and 802 are in series – the second OCM unit 802 receives OCM effluent from the first OCM unit 801. Each OCM unit 801 and 802 includes an OCM reactor that is configured to react methane with an oxidizing agent to generate C₂₊ compounds. One or both of the OCM units 801 and 802 can include a PBC reactor downstream of the OCM reactor. In the illustrated example, the second OCM unit 802 comprises a PBC reactor downstream of the OCM reactor of the second OCM unit 802.

[00181] During use, oxygen along stream 803 is directed into the OCM units 801 and 802. Methane is directed to the first OCM unit 801 along stream 804. In the first OCM unit 801, methane and oxygen react in an OCM process to yield an OCM effluent stream 805 that is directed to a heat exchanger and subsequently the second OCM unit 802. The second OCM unit 802 generates additional C₂₊ compounds from oxygen and any unreacted methane in the stream 805. In addition, the second OCM unit 802 accepts ethane along stream 806 into the PBC reactor of the second OCM unit 802, and generates ethylene from the ethane. C₂₊ compounds generated in the second OCM unit 802, along with any non-C₂₊ impurities are directed out of the second OCM unit 802 along stream 807 to multiple heat exchangers and subsequently a separator 808, which removes water from the OCM effluent stream. Water is directed out of the separator 808 along stream 809, and C₂₊ compounds and any non-C₂₊ impurities are directed along stream 810.

[00182] The system 800 further includes a methanation unit 811 that generates methane from H₂ and CO and/or CO₂. Methane generated in the methanation unit 811 is directed along stream 804 to the first OCM unit 801. The methanation unit 811 may be as described elsewhere

herein. Methane, such as recycled methane, is directed along stream **812** through a heat exchanger and to the methanation unit **811**. CO and/or CO₂ are directed to the methanation unit **811** along stream **813**.

[00183] The system **800** includes process stream that is used in the heat exchangers. Process steam is directed along stream **814** to various heat exchangers and is outputted along stream **815** and 816.

[00184] Although the system **800** includes two OCM units **801** and **802**, the system **800** can include any number of OCM units in series and parallel. An OCM unit can be an OCM reactor with an OCM catalyst. The system **800** can include at least 1, 2, 3, 4, 5, 6, 7, 8, 9, or 10 OCM units.

[00185] The stream **810** may be directed to a hydrogenation reactor and separation train to convert any acetylene in the stream **810** to ethane and/or ethylene, and separate the ethane from ethylene. For world scale ethylene generation, the system **300** of **FIG. 3** may be employed. A PSA unit may be used to separate H₂ from N₂ in a stream comprising H₂ and N₂.

[00186] With reference to **FIG. 8B**, the stream **810** is directed into a series of compressors **817** and separators **818**, which raise the pressure of the stream **810** (e.g., by a factor of from about 2.5:1 to 4:1) and remove water from the stream **810**. The separators may be quench towers. Water removed from a first of the separators **818** is directed along stream **819**. The pressurized stream **820** (which includes C₂₊ compounds) can be mixed with methane from stream **821** (e.g., natural gas stream or methane from a methanation unit) and subsequently directed to an absorption system **822** for removing CO₂ from the stream **820**. The absorption system **822** can be an amine system. The absorption system **822** comprises an absorption unit **823**, a regenerator **824** and a scrubber **825**. The absorption unit **823** can employ an aqueous solution of various alkylamines (also “amines” herein) to scrub CO₂ and H₂S from the stream **820**. Examples of amines include, without limitation, diethanolamine, monoethanolamine, methyldiethanolamine and diisopropanolamine. The resultant “rich” amine is then routed into the regenerator **824** (e.g., a stripper with a reboiler) to produce regenerated or “lean” amine that is recycled for reuse in the absorption unit **823**. The separated CO₂ can be purged **826** or recycled **827** (e.g., to a methanation system).

[00187] The absorption unit **823** generates an effluent stream that can have a low CO₂ content, which is directed to the scrubber **825**. The scrubber **825** removes additional CO₂ from the stream, using, for example, a sodium hydroxide stream that is directed through the scrubber **825** in a counter flow configuration. The stream **828** is then directed from the scrubber **825** to a separator **829**, which removes water from the stream **828**. The removed water is directed along

stream **819** and the C_{2+} compounds and non- C_{2+} impurities are directed to dryers **830**, and subsequently directed along stream **831**. The OCM effluent stream **828** may be cooled in a heat exchanger upon heat transfer to a C_1 recycle stream, for example.

[00188] The system of **FIG. 8B** employs various heat exchangers. A C_1/N_2 stream is directed along stream **832** to a heat exchanger and removed along streams **833** and **834**. Process stream **835**, which can comprise methane, is directed to another heat exchanger, and a portion of process stream **835** is then directed along stream **834** and a remainder is directed along stream **836**. A C_1 purge from, for example, a PSA unit, may be directed along stream **837** to stream **834**.

[00189] In **FIGs. 8A-8B**, in some examples, the separators **808** and **818** can be liquid/liquid separators or gas/liquid separators. For example, the separator **808** or **818** can be a gas/liquid separator.

[00190] One or more ethylene recovery sections (including, for example, separations units and cryogenic units) can comprise a series of fractionation towers to separate and recover products. The cooling to condense each of the column overhead vapors can be provided by multiple ways. The lowest temperature required is to condense demethanizer overhead vapors. In some cases, the demethanizer overhead vapor is expanded and the chill is utilized to cool the incoming feed streams.

[00191] A recycle split vapor (RSV) process can be employed. An RSV process can comprise a full RSV (modified for the OCM plant) with a propylene refrigerant, or a full three-refrigerant system typical of an ethylene plant (methane refrigerant, ethylene refrigerant and propylene refrigerant, or use a mixed refrigerant composed of two or more of these refrigerants). In some cases, a combination of these two options (i.e. RSV or modified RSV combined with utilization of one or more of the three typical refrigeration systems) can be used to provide for the refrigeration duty to the OCM system separation section.

[00192] In natural gas processing plants or NGLs fractionation unit, methane can be separated from ethane and higher carbon-content hydrocarbons (conventionally called natural gas liquids or NGLs) to produce a methane-rich stream that can meet the specifications of pipelines and sales gas. Such separation can be performed using cryogenic separation, such as with the aid of one or more cryogenic units, and/or by implementing one of the gas processing technologies (e.g., RSV) for maximum or optimum recovery of the NGLs.

[00193] The raw natural gas fed to gas processing plants can have a molar composition of 70% to 90% methane and 4% to 20% NGLs, the balance being inert gas(es) (e.g., CO_2 and N_2). The ratio of methane to ethane can be in the range of 5-25. Given the relatively large amount of

methane present in the stream fed to cryogenic sections of gas processing plants, at least some or substantially all of the cooling duty required for the separation is provided by a variety of compression and expansion steps performed on the feed stream and the methane product stream. None or a limited portion of the cooling duty can be supplied by external refrigeration units.

[00194] There are various approaches for separating higher carbon alkanes (e.g., ethane) from natural gas, such as recycle split vapor (RSV) or any other gas processing technologies and/or gas sub-cooled process (GSP) processes, which may maximize the recovery of ethane (e.g., >99%, 98%, 97%, 96% or 95% recovery) while providing most or all of the cryogenic cooling duty via internal compression and expansion of portion of the natural gas itself (e.g., at least about 10%, 15%, 20%, 25%, 30%, 35%, 40%, or 50%). However, the application of such approach in separating alkenes (e.g., ethylene) from an OCM product stream comprising methane is novel and may result in a limited recovery in some cases when inert gas is present (e.g., provide less than 95% recovery) of the alkene product, due at least in part to i) the different vapor pressure of alkenes and alkanes, and/or ii) the presence of significant amounts of H₂ in the OCM product stream, which can change the boiling curve and, particularly, the Joule-Thomson coefficient of the methane stream that needs to be compressed and expanded to provide the cooling duty. Hydrogen can display a negative or substantially low Joule-Thomson coefficient, which can cause a temperature increase or a substantially low temperature decrease in temperature when a hydrogen-rich stream is expanded.

[00195] In some embodiments, the design of a cryogenic separation system of an OCM-based plant can feature a different combination of compression / expansion steps for internal refrigeration and, in some cases, external refrigeration. The present disclosure provides a separation system comprising one or more cryogenic separation units and one or more demethanizer units. Such a system can maximize alkene recovery (e.g., provide greater than 95% recovery) from a stream comprising a mixture of alkanes, alkenes, and other gases (e.g., H₂), such as in an OCM product stream.

[00196] In such separation system, the cooling duty can be supplied by a combination of expansion of the OCM effluent (feed stream to the cryogenic section) when the OCM effluent pressure is higher than a demethanizer column; expansion of at least a portion or all of the demethanizer overhead methane-rich stream; compression and expansion of a portion of the demethanizer overhead methane-rich stream; and/or external propane, propylene or ethylene refrigeration units.

[00197] **FIGs. 9-12** show various separation systems that can be employed with various systems and methods of the present disclosure, including small scale and world scale systems.

FIG. 9 shows a separation system **900** comprising a first heat exchanger **901**, a second heat exchanger **902**, a demethanizer **903**, and a third heat exchanger **904**. The direction of fluid flow is shown in the figure. The demethanizer **903** can be a distillation unit or multiple distillation units (e.g., in series). In such a case, the demethanizer can include a reboiler and a condenser, each of which can be a heat exchanger. An OCM effluent stream **905** is directed to the first heat exchanger **901** at a pressure from about 10 to 100 bar (absolute), or 20 to 40 bar. The OCM effluent stream **905** can include methane and C₂₊ compounds, and may be provided in an OCM product stream from an OCM reactor (not shown). The OCM effluent stream **905** is then directed from the first heat exchanger **901** to the second heat exchanger **902**. In the first heat exchanger **901** and the second heat exchanger **902**, the OCM effluent stream **905** is cooled upon heat transfer to a demethanizer overhead stream **906**, a demethanizer reboiler stream **907**, a demethanizer bottom product stream **908**, and a refrigeration stream **909** having a heat exchange fluid comprising propane or an equivalent cooling medium, such as, but not limited to, propylene or a mixture of propane and propylene.

[00198] The cooled OCM effluent **905** can be directed to the demethanizer **903**, where light components, such as CH₄, H₂ and CO, are separated from heavier components, such as ethane, ethylene, propane, propylene and any other less volatile component present in the OCM effluent stream **905**. The light components are directed out of the demethanizer along the overhead stream **906**. The heavier components are directed out of the demethanizer along the bottom product stream **908**. The demethanizer can be designed such that at least about 60%, 70%, 80%, 90%, or 95% of the ethylene in the OCM effluent stream **905** is directed to the bottom product stream **908**.

[00199] The demethanizer overhead stream **906** can contain at least 60%, 65%, 70%, 75%, or 80% methane. The overhead stream **906** can be expanded (e.g., in a turbo-expander or similar machine or flashed over a valve or similar device) to decrease the temperature of the overhead stream **906** prior to directing the overhead stream **906** to the second heat exchanger **902** and subsequently the first heat exchanger **901**. The overhead stream **906** can be cooled in the third heat exchanger **904**, which can be cooled using a reflux stream and a hydrocarbon-containing cooling fluid, such as, for example, ethylene.

[00200] The overhead stream **906**, which can include methane, can be recycled to an OCM reactor and/or directed for other uses, such as a natural gas pipeline. In some examples, the bottom product stream, which can contain C₂₊ compounds (e.g., ethylene), can be directed to an ETL system.

[00201] FIG. 10 shows another separation system 1000 that may be employed for use with systems and methods of the present disclosure. The direction of fluid flow is shown in the figure. The system 1000 comprises a first heat exchanger 1001, demethanizer 1002 and a second heat exchanger 1003. The demethanizer 1002 can be a distillation unit or multiple distillation units (e.g., in series). An OCM effluent stream 1004 is directed into the first heat exchanger 1001. The OCM effluent stream 1004 can include methane and C₂₊ compounds, and may be provided in an OCM product stream from an OCM reactor (not shown). The OCM effluent stream 1004 can be provided at a pressure from about 10 bar (absolute) to 100 bar, or 40 bar to 70 bar. The OCM effluent stream 1004 can be cooled upon heat transfer to a demethanizer overhead streams 1005 and 1006 from the second heat exchanger 1003, a demethanizer reboiler stream 1007, and a refrigeration stream having a cooling fluid comprising, for example, propane or an equivalent cooling medium, such as, but not limited to, propylene or a mixture of propane and propylene. In some cases, the demethanizer overhead streams 1005 and 1006 are combined into an output stream 1012 before or after passing through the first heat exchanger 1001.

[00202] Subsequent to cooling in the first heat exchanger 1001, the OCM effluent stream 1004 can be expanded in a turbo-expander or similar device or flashed over a valve or similar device to a pressure of at least about 5 bar, 6 bar, 7 bar, 8 bar, 9 bar, or 10 bar. The cooled OCM effluent stream 1004 can then be directed to the demethanizer 1002, where light components (e.g., CH₄, H₂ and CO) are separated from heavier components (e.g., ethane, ethylene, propane, propylene and any other less volatile component present in the OCM effluent stream 1004). The light components are directed to an overhead stream 1009 while the heavier components (e.g., C₂₊) are directed along a bottoms stream 1010. A portion of the overhead stream 1009 is directed to second heat exchanger 1003 and subsequently to the first heat exchanger 1001 along stream 1006. A remainder of the overhead stream 1009 is pressurized (i.e., pressure is increased) in a compressor and directed to the second heat exchanger 1003. The remainder of the overhead stream 1009 is then directed to a phase separation unit 1011 (e.g., distillation unit or vapor-liquid separator). Liquids from the phase separation unit 1011 are directed to the second heat exchanger 1003 and subsequently returned to the demethanizer 1002. Vapors from the phase separation unit 1011 are expanded (e.g., in a turbo-expander or similar device) and directed to the second heat exchanger 1003, and thereafter to the first heat exchanger along stream 1005. The demethanizer 1002 can be designed such that at least about 60%, 70%, 80%, 90%, or 95% of the ethylene in the OCM effluent stream 1004 is directed to the bottom product stream 1010.

[00203] FIG. 11 shows another separation system 1100 that may be employed for use with systems and methods of the present disclosure. The direction of fluid flow is shown in the

figure. The system **1100** comprises a first heat exchanger **1101**, a demethanizer **1102**, a second heat exchanger **1103** and a third heat exchanger **1104**. The system **1100** may not require any external refrigeration. The demethanizer **1102** can be a distillation unit or multiple distillation units (e.g., in series). An OCM effluent stream **1105** is directed to the first heat exchanger **1101** at a pressure from about 10 bar (absolute) to 100 bar, or 40 bar to 70 bar. In the first heat exchanger **1101**, the OCM effluent stream **1105** can be cooled upon heat transfer to demethanizer overhead streams **1106** and **1107**, a demethanizer reboiler stream **1108** and a demethanizer bottom product stream **1109**. In some cases, the demethanizer overhead streams **1106** and **1107** are combined into a common stream **1115** before or after they are passed through the first heat exchanger **1101**. The OCM effluent stream **1105** is then expanded to a pressure of at least about 5 bar, 6 bar, 7 bar, 8 bar, 9 bar, 10 bar, or 15 bar, such as, for example, in a turbo-expander or similar machine or flashed over a valve or similar device. The cooled OCM effluent stream **1105** is then directed to the demethanizer **1102**, where light components (e.g., CH₄, H₂ and CO) are separated from heavier components (e.g., ethane, ethylene, propane, propylene and any other less volatile component present in the OCM effluent stream **1105**). The light components are directed to an overhead stream **1110** while the heavier components are directed along the bottom product stream **1109**. The demethanizer **1102** can be designed such that at least about 60%, 70%, 80%, 90%, or 95% of the ethylene in the OCM effluent stream **1105** is directed to the bottom product stream **1109**.

[00204] The demethanizer overhead stream **1110**, which can contain at least 50%, 60%, or 70% methane, can be divided into two streams. A first stream **1111** is compressed in compressor **1112** and cooled in the second heat exchanger **1103** and phase separated in a phase separation unit **1113** (e.g., vapor-liquid separator or distillation column). Vapors from the phase separation unit **1113** are expanded (e.g., in a turbo-expander or similar device) to provide part of the cooling duty required in heat exchangers **1101**, **1103** and **1104**. Liquids from the phase separation unit **1113** are sub-cooled in the third heat exchanger **1104** and recycled to the demethanizer **1102**. A second stream **1114** from the overhead stream **1110** can be expanded (e.g., in a turbo-expander or similar device) to decrease its temperature and provide additional cooling to the heat exchangers **1101**, **1103** and **1104**.

[00205] FIG. 12 shows another separation system **1200** that may be employed for use with systems and methods of the present disclosure. The direction of fluid flow is shown in the figure. The system **1200** comprises a first heat exchanger **1201**, a demethanizer **1202**, and a second heat exchanger **1203**. An OCM effluent stream **1204** is directed to the first heat exchanger **1201** at a pressure from about 2 bar (absolute) to 100 bar, or 3 bar to 10 bar. The first

heat exchanger **1201** can interface with a propane refrigeration unit **1215** and/or an ethylene refrigeration unit **1216**. In the first heat exchanger **1201**, the OCM effluent stream **1204** can be cooled upon heat transfer to demethanizer overhead streams **1205** and **1206**, a demethanizer reboiler stream, a demethanizer pump-around stream, and various levels of external refrigeration, such as using cooling fluids comprising ethylene and propylene. In some cases, the demethanizer overhead streams **1205** and **1206** are combined into a single stream **1214** before or after they are cooled. The cooled OCM effluent stream **1204** is then directed to the demethanizer **1202**, where light components (e.g., CH₄, H₂ and CO) are separated from heavier components (e.g., ethane, ethylene, propane, propylene and any other less volatile component present in the OCM effluent stream **1204**). The light components are directed to an overhead stream **1207** and the heavier components are directed along a bottom product stream **1208**. The demethanizer **1202** can be designed such that at least about 60%, 70%, 80%, 90%, or 95% of the ethylene in the OCM effluent stream **1204** is directed to the bottom product stream **1208**.

[00206] The demethanizer overhead stream, which can contain at least about 50%, 60%, 70%, or 80% methane, can be divided into two streams. A first stream **1213** can be compressed in a compressor **1209**, cooled in the second heat exchanger **1203** and phase-separated in a phase separation unit **1210** (e.g., distillation column or vapor-liquid separator). Vapors from the phase separation unit **1210** can be expanded (e.g., in a turbo-expander or similar device) to provide part of the cooling duty required for the heat exchanger **1201** and **1203**. Liquids from the phase separation unit **1210** can be sub-cooled and flashed (e.g., over a valve or similar device), and the resulting two-phase stream is separated in an additional phase separation unit **1211**. Liquids from the additional phase separation unit **1211** are recycled to the demethanizer **1202** and vapors from the additional phase separation unit are mixed with expanded vapors from the phase separation unit **1210** prior to being directed to the second heat exchanger **1203**.

[00207] A second stream **1212** from the overhead stream **1207** can be expanded (e.g., in a turbo-expander or similar device) to decrease its temperature and provide additional cooling for the heat exchanger **1201** and **1203**. Any additional cooling that may be required for the second heat exchanger **1203** can be provided by an external refrigeration system, which may employ a cooling fluid comprising ethylene or an equivalent cooling medium.

[00208] In some cases, recycle split vapor (RSV) separation can be performed in combination with demethanization. In such a case, at least a portion of the overhead stream from a demethanizer unit (or column) may be split into at least two streams (see, e.g., **FIGs. 10-12**). At least one of the at least two streams may be pressurized, such as in a compressor, and directed to a heat exchanger.

[00209] In some instances, the methane undergoes an OCM and/or ETL process to produce liquid fuel or aromatic compounds (e.g., higher hydrocarbon liquids) and contains molecules that have gone through methanation. In some embodiments, the compounds have been through a recycle split vapor (RSV) separation process. In some cases, alkanes (e.g., ethane, propane, butane) are cracked in a post-bed cracker.

[00210] It will be appreciated that systems and methods described herein are provided as examples and that various alternatives may be employed. It will be further appreciated that components of systems described herein are interchangeable. For instance, components for use in small scale production may be employed for use in world scale production, and vice versa.

Air Separation Units (ASU) and Power Production

[00211] An OCM reaction can convert a natural gas into a stream containing ethane, ethylene and other short olefins and alkanes, such as propene and propane. Unlike conventional (i.e., non-OCM) cracking-based production technologies for olefin production which may utilize energy to sustain the cracking reaction, the OCM process can generate power from the exothermic OCM reaction itself. Provided herein are systems and methods that can utilize the OCM reaction heat for steam generation, which in turn can be exploited for power generation.

[00212] In an OCM process, methane can react with an oxidizing agent such as oxygen over an OCM catalyst to generate ethylene. A wide set of competitive reactions can occur simultaneously over the OCM catalyst, including combustion of both methane and partial oxidations. Natural gas can be the source of methane, and can be combined with one or more recycle streams coming from downstream separation units (e.g., which can contain methane and ethane). Air, enriched air or pure oxygen can be used to supply the oxygen required for the reaction. All these reactions are exothermic and the relevant reaction heat can be recovered in order to cool the reactor effluent and feed the effluent to a downstream compressor, which can then send the effluent stream to downstream separation and recovery units.

[00213] Several process configurations can be adopted to enable the efficient recovery of the reaction heat. In some cases, the process utilizes the OCM reaction heat to i) supply the heat for the endothermic cracking reactions that convert the additional ethane feed to ethylene; and ii) generate steam to drive a downstream compressor. This process can achieve energy neutrality (no need for energy import or export to conduct the overall process), however it can require a relatively large number of unit operations which can lead to operational complexity, large capital costs and high pressure drops between the reactor outlet and the compressor suction. When the OCM process is combined with power generation, the integrated OCM-power process can be a

simpler and more efficient process when compared to an individual OCM process and a separate power production unit producing the same amounts of ethylene and power.

[00214] This flexibility and synergy between olefin and power production can be exploited as a design feature and/or an operating feature. That is, the process configuration of an integrated OCM-power system can be designed in order to maximize ethylene production, or power production, or for any intermediate level of production of the two products. In the case of maximum ethylene production, the flow of the ethane stream injected into the OCM reactor can be maximized to conduct cracking reactions to the maximum allowable extent. If the OCM reactor is adiabatic, the maximum extent of cracking corresponds to designing the system to crack an amount of ethane that results in a decrease in temperature to the minimum viable temperature for cracking. In the case of maximum power production, the system can be designed for minimum ethane injection, which can be limited by the highest possible temperature at the outlet of the OCM reactor and, accordingly, the maximum amount of steam generation. The combined OCM-power system can be designed to operate at any level of power and olefin production in between these two constraints.

[00215] The same flexibility and synergy between ethylene and power production can be achieved at an operating level. For example, the combined OCM-power process can be designed to handle both the maximum olefin and the maximum power cases. In such cases, the plant operator has the ability to change the amount of ethylene and power production during operations by deciding at any given time the amount of ethane to be injected into the OCM reactor. This operating feature can be particularly advantageous for optimizing the financial performance of the plant once it is built because it can allow variation of the composition of the product portfolio at any given time based on the real time prices of the respective products.

[00216] An aspect of the present disclosure provides an oxidative coupling of methane (OCM) system for production of olefins and power. The system can include an OCM subsystem that takes as input a feed stream comprising methane (CH₄) and a feed stream comprising an oxidizing agent such as oxygen, and generates a product stream comprising C₂₊ compounds and heat from the methane and the oxidizing agent. The system can further include a power subsystem fluidically or thermally coupled to the OCM subsystem that converts the heat into electrical power.

[00217] The OCM subsystem can have at least one OCM reactor and at least one post-bed cracking unit within the OCM reactor or downstream of the OCM reactor. The post-bed cracking unit can be configured to convert at least a portion of alkanes in the product stream to alkenes. In some cases, the power subsystem has one or more turbines and can be a gas turbine combined

cycle (GTCC). In some embodiments, the system further comprises a heat recovery steam generator (e.g., HRSG) for generating steam from the heat and the steam can be converted to electrical power in the power subsystem. In some instances, the power subsystem comprises a gas turbine and un-reacted methane from the OCM subsystem is converted to electrical power using the gas turbine.

[00218] Another aspect of the present disclosure provides a method for producing at least one C₂₊ alkene and power. The method can include directing methane and an oxidizing agent into a reactor comprising a catalyst unit, where the catalyst unit comprises an oxidative coupling of methane (OCM) catalyst that facilitates an OCM reaction that produces C₂₊ alkene. The method can include reacting the methane and oxidizing agent with the aid of the OCM catalyst to generate at least one OCM product comprising at least one C₂₊ compound and heat. Electrical power can be generated from the heat.

[00219] In some cases, the heat is converted to steam and the steam is converted to power in a steam turbine. In some cases, un-reacted methane from the reactor is converted to electrical power in a gas turbine. In some instances, the reactor includes a cracking unit downstream of the catalyst unit, where the cracking unit generates C₂₊ alkene from C₂₊ alkane. The method can further include providing at least one hydrocarbon-containing stream that is directed through the cracking unit, which hydrocarbon-containing stream has at least one C₂₊ alkane. At least one C₂₊ alkane can be cracked to provide the at least one C₂₊ alkene in a product stream that is directed out of the reactor. In some embodiments, the hydrocarbon-containing stream comprises at least one OCM product. The C₂₊ alkene produced from the hydrocarbon-containing stream in the cracking unit can be in addition to the C₂₊ alkene produced from the methane and the oxidizing agent in the reactor. In some embodiments, the amount of steam produced is varied or the amount of at least one hydrocarbon-containing stream that is directed through the cracking unit is varied to alter the amount of electrical power produced and the amount of C₂₊ alkene produced.

[00220] FIG. 13 shows an example of a HRSG system 1300 that may be employed for use as the HRSG 507. The HRSG system 1300 comprises a gas turbine 1301, HRSG 1302, power generation unit 1303 and an air separation unit (ASU) 1304. The system 1300 comprises streams 1305, 1306, 1309 and 1310.

[00221] During use, the HRSG 1302 can transfer heat to a methane-containing stream (e.g., methane-containing stream 505). Purge gas from an OCM process can be burned to compress air as feed to ASU unit 1304. Additional high pressure steam may be provided along stream 1306. Power generated by the power generation unit 1303 can be directed to an OCM

system **1307**, an energy storage unit or power distribution system **1308**, and/or the ASU **1304**. The air separation unit accepts compressed air from the gas turbine **1301** and separates the compressed air to O₂ that is directed along stream **1309** and N₂, which can be purged. The HRSG system **1300** further comprises a purge stream **1305** that is directed into the gas turbine, and a flue gas stream **1310** that is directed out of the HRSG **1302**.

[00222] **FIG. 14** shows an example of an OCM process for producing ethylene and power. Natural gas **1402** and in some cases, additional ethane **1404**, can be cleaned of sulfur-containing compounds in a de-sulfurization unit **1406** and fed into a process gas compressor **1408**. Carbon dioxide (CO₂) **1410** can be removed in a process gas cleanup module **1412** and fed to the methanation reactor **1426** (connection not shown). The gas cleaned of CO₂ can be fed into a separations module **1414** where one or more product fractions **1416** can be isolated (e.g., C₂, C₃, C₄₊ compounds).

[00223] Alkanes such as ethane can be recycled **1418** from the separations module to the OCM reactor **1420**, where they can be injected into the post-bed cracking region of the reactor to generate olefins from the alkanes. The alkane recycle stream **1418** can be heated in a heat exchanger or a heat recovery steam generator (HRSG) **1422** (for simplicity, connection to HRSG not shown). Carbon monoxide **1424** from the separations module **1414** and carbon dioxide from module **1412** (connection not shown) can be fed into a methanation reactor **1426** along with hydrogen **1424** for conversion to methane. The methane recycle **1428** can be heated in the HRSG **1422** and returned to the OCM reactor **1420**.

[00224] The HRSG can provide high-pressure steam **1430** to a steam turbine **1432** to produce power **1434**. The steam and energy to heat the steam can be sourced from any suitable part of the process including from the OCM reactor **1436**. Additional sources of steam and/or heat can include from combustion of fuel gas **1438** provided from the separations module, from the exhaust **1440** from a gas turbine **1445**, and/or from cooling the effluent from the OCM reactor **1420** (not shown). Additional fuel gas **1450** can be provided to the gas turbine **1445**. The gas turbine can produce electrical power **1455** and can drive a compressor (e.g., on the same shaft with the power generator) to supply compressed air **1460** for an air separation unit (ASU) **1465** or a vacuum pressure swing adsorption (VPSA) unit to supply oxygen to the OCM reactor **1420**.

[00225] The combined OCM-power process shown in **FIG. 14** can have numerous advantages over processes without power integration (e.g., **FIGs. 26-31**). For example, the total number of unit operations can be lower due to the heat recovery section of the combined cycle GTCC (that recovers the heat from the gas turbine exhaust) being utilized for OCM-related

services, thus making a feed-product exchanger and a steam superheater redundant. The lower number of unit operations can lead to lower capital cost and operational simplicity. The pressure drop from the OCM reactor outlet to the compressor suction can be reduced by up to 2 bar due to the elimination of two large heat exchangers when integrating OCM with power production. The reduced pressure drop can lead to an increased process efficiency (due to the lower power consumption in compressors) and a lower capital cost (due to the smaller size of the compressors).

Oxidizing Agents

[00226] An OCM process requires the presence of an oxidizing agent. The oxidizing agent can be oxygen supplied from air fed to the reactor. In some cases the oxidizing agent can be pure oxygen, supplied by pipeline or recovered from air. In some cases oxygen can be separated from air by cryogenic distillation, as in an Air Separation Unit. In some cases, various membrane separation technologies can be applied to generate an oxygen rich stream. In certain cases, the oxygen stream can be produced by a pressure swing adsorption (PSA) unit or a vacuum pressure swing adsorption (VPSA) unit. In certain cases, while using air as the oxidizing agent, a nitrogen recovery unit (NRU) can be used to reduce the nitrogen content in the OCM reactor system. See, e.g., U.S. Patent Application No. 13/739,954 and U.S. Patent Application No. 13/936,870, which are entirely incorporated herein by reference.

Ethane Skimming

[00227] Systems and methods of the present disclosure can be used to convert both methane and ethane to ethylene, in some cases along with some co-products and by-products. Ethane can be fed directly into a post-bed cracker (PBC), which can be a portion of an OCM reactor downstream of the OCM catalyst, where the heat generated in the OCM reaction can be used to crack the ethane to ethylene. As an alternative, the PBC can be a unit that is separate from the OCM reactor and in some cases in thermal communication with the OCM reactor. The ethane feed stream to the OCM reactor can include (a) ethane recycled to the OCM reactor from an OCM reactor effluent stream, which can be separated in at least one downstream separation module and recycled to the OCM reactor, (b) ethane present in other feed streams (e.g., natural gas), which can be separated in at least one separation module and recycled to the OCM reactor, and (c) any additional (i.e., fresh) ethane feed.

[00228] The maximum amount of ethane that can be converted in the PBC can be limited by the flow rate of material exiting the OCM catalyst and/or its temperature. It can be advantageous to utilize a high proportion of the maximum amount of PBC. In some cases, the amount of ethane converted to ethylene is about 50%, about 60%, about 70%, about 80%, about

85%, about 90%, about 95%, or about 99% of the maximum amount of ethane that can be converted to ethylene in the PBC. In some instances, the amount of ethane converted to ethylene is at least about 50%, at least about 60%, at least about 70%, at least about 80%, at least about 85%, at least about 90%, at least about 95%, or at least about 99% of the maximum amount of ethane that can be converted to ethylene in the PBC.

[00229] Achieving a high proportion (e.g., greater than or equal to about 60%, 70%, or 80%) of the maximum PBC capacity can be accomplished by adding natural gas to the system, which can have a concentration of ethane that depends on many factors, including the geography and type and age of the natural gas well. The treatment and separation modules of the OCM process described herein can be used to purify the OCM effluent, but can be used to treat (e.g., remove water and CO₂) and purify the natural gas that is added to the system along with the OCM effluent, such as, e.g., by separating C₂₊ compounds from methane and separating ethane from ethylene. In some cases, ethane contained in the natural gas feed can be recycled to the OCM reactor (e.g., PBC region) as pure ethane and the system may not be sensitive to the purity and composition of the natural gas, making raw natural gas a suitable input to the system.

[00230] The maximal PBC capacity can depend on the ratio between methane and ethane in the input to the OCM reactor, including in some instances the PBC portion. In some cases, the PBC capacity is saturated when the molar ratio of methane to ethane is about 1, about 2, about 3, about 4, about 5, about 6, about 7, about 8, about 9, about 10, about 11, about 12, about 13, about 14, or about 15. In some cases, the PBC capacity is saturated when the molar ratio of methane to ethane is at least about 1, at least about 2, at least about 3, at least about 4, at least about 5, at least about 6, at least about 7, at least about 8, at least about 9, at least about 10, at least about 11, at least about 12, at least about 13, at least about 14, or at least about 15. In some cases, the PBC capacity is saturated when the molar ratio of methane to ethane is at most about 5, at most about 6, at most about 7, at most about 8, at most about 9, at most about 10, at most about 11, at most about 12, at most about 13, at most about 14 or at most about 15. In some cases, the PBC capacity is saturated when the molar ratio of methane to ethane is between about 7 and 10 parts methane to one part ethane.

[00231] Natural gas (raw gas or sales gas) can have a concentration of ethane of less than about 30 mol%, 25 mol%, 20 mol%, 15 mol%, 10 mol%, 9 mol%, 8 mol%, 7 mol%, 6 mol%, 5 mol%, 4 mol%, 3 mol%, 2 mol% or 1 mol%. In some cases, natural gas has a methane to ethane ratio greater than about 1:1, 2:1, 3:1, 4:1, 5:1, 6:1, 7:1, 8:1, 9:1, 10:1, 11:1, 12:1, 13:1, 14:1, 15:1, 16:1, 17:1, 18:1, 19:1, 20:1 or 40:1. The ethane skimmer implementation of OCM described herein can be used to inject more natural gas feed into the system than what may be required to

produce the desired or predetermined amount of ethylene. The excess methane can be drawn from a stream downstream of the methanation unit and sold as sales gas (which may lack an appreciable amount of ethane but can still meet pipeline specifications and/or can be directed to a power plant for power production). The ethane in the additional natural gas feed can be used to saturate the PBC capacity. Any excess ethane can be drawn from the C₂ splitter and exported as pure ethane. The ethane skimmer implementation described herein can result in additional product streams from the OCM system (namely sales gas and natural gas liquids). In such a case, the OCM process can be used to achieve both ethylene production and natural gas processing.

[00232] The ethane skimmer implementation can be readily understood by reference to **FIG. 15** (showing additional ethane feed to saturate PBC) and **FIG. 16** (showing the ethane skimmer implementation). In **FIG. 15**, at least some or most (e.g., >70%, >80%, >85%, >90%, >95%, or >99%) of the methane in the natural gas (NG) feed **1500** ends up in the methane recycle **1505**, at least some or most (e.g., >70%, >80%, >85%, >90%, >95%, or >99%) of the ethane in the NG feed ends up in the ethane recycle stream **1510**, at least some or most (e.g., >70%, >80%, >85%, >90%, >95%, or >99%) propane in the NG feed ends up in the C₃ mixed products stream (e.g., Refinery Grade Propylene (RPG)) **1515**, at least some or most (e.g., >70%, >80%, >85%, >90%, >95%, or >99%) of the C₄₊ in the NG feed ends up in the C₄ mixed stream **1520**, and ethane is added **1525** up to the point where the PBC cracking capacity **1530** is saturated or nearly saturated (e.g., >70%, >80%, >85%, >90%, >95%, or >99%). In contrast, in the ethane skimmer implementation (**FIG. 16**), some of the methane (any proportion) can end up in a sales gas stream **1600** and if there is excess ethane, it can end up in an ethane product stream **1605**. The ethane skimmer implementation does not require a separate (i.e., fresh) ethane stream to saturate or nearly saturate the PBC capacity of the system.

Gas Processing Plants

[00233] An OCM process for generating olefins (e.g., ethylene) can be a standalone process, or it can be integrated in other processes, such as non-OCM processes (e.g., NGL process). **FIG. 17** shows a system **1700** comprising an existing gas plant **1701** that has been retrofitted with an OCM system **1702** (or with an OCM-ETL system for the production of other olefins (e.g., propylene)). A raw natural gas (NG) feed **1703** is directed into the existing gas plant **1701**, which comprises a treatment unit **1704**, NGL extraction unit **1705**, compression unit **1706** and fractionation unit **1707**. The NGL extraction unit **1705** can be a gas processing unit that can use a gas processing recovery technology such as a recycle split vapor (RSV) technology or other technologies. The NGL extraction unit **1705** can be a demethanizer unit,

optionally a demethanizer unit incorporated with a recycle split vapor (RSV) retrofit or standalone unit. The treatment unit **1704** can remove water, H₂S and CO₂ from the NG feed **1703** and direct natural gas to the NGL extraction or processing unit **1705**. The NGL extraction unit **1705** can remove NGLs (e.g., ethane, propane, butane, etc.) from methane and direct methane (with some traces of NGLs and inert gas) to the compression unit **1706** along fluid stream **1708**. NGLs or C₂₊ components can be directed to fractionation unit **1707**. At least a portion or almost all of the methane (e.g., 10%, 20%, 30%, 40%, 50%, 60%, 70%, 80%, 90%, or 99%) from the fluid stream **1708** is directed along stream **1709** to an OCM reactor **1710** of the OCM system **1702**. This integration of an OCM system (in some other cases OCM-ETL system) with an existing natural gas processing or NGLs extraction plant can improve the recovery of olefin/s production by implementing one of the gas processing technologies (e.g., RSV). This integration is suitable for a small scale and world scale olefin production (e.g., ethylene production).

[00234] With continued reference to **FIG. 17**, the compression unit **1706** compresses methane in the fluid stream **1708** and directs compressed methane to a methanation system **1711**, which converts any CO, CO₂ and H₂ in the fluid stream **1708** to methane, which is then directed to natural gas pipeline **1712** for distribution to end users. In some cases, the methanation outlet stream can be treated to remove water (not shown). The dryer system can consist one or more of the following. A bed or multiple desiccant (molecular sieve) beds, separator vessels to condense and separate the water.

[00235] The NGLs extraction unit **1705** can extract C₂₊ compounds from the NG feed **1703**. NGLs or C₂₊ compounds from the NGL extraction unit **1705** are directed to the fractionation unit **1707**, which can be a distillation column. The fractionation unit **1707** splits the C₂₊ compounds into streams comprising various C₂₊ compounds, such as a C₂ stream along with C₃, C₄ and C₅ streams. The C₂ stream can be directed to a C₂ splitter **1713** (e.g., distillation column), which separates ethane from ethylene. Ethane is then directed along stream **1714** to a post-bed cracking (PBC) unit **1715** of the OCM system **1702**. In some cases, C₃ and/or C₄ compounds can be taken from the C₂ splitter **1713** and fed into a downstream region of a post-bed cracking (PBC) reactor for olefin production. In some situations, C₄ and/or C₅ streams can be directed to a C₄ or C₅ splitter (e.g., a distillation column), which, for example, separate iso-butane (iC₄) from normal butane (nC₄) and/or separate iso-pentane (iC₅) from normal pentane (nC₅). In some situations, other alkanes, such as propane and butane, can be directed to the PBC unit **1715**.

[00236] In the OCM system 1702, methane from the stream 1709 and oxygen along stream 1716 are directed to the OCM reactor 1719. The OCM reactor 1710 generates an OCM product (or effluent) stream comprising C₂₊ compounds in an OCM process, as discussed elsewhere herein. C₂₊ alkanes (e.g., ethane) in the product stream, as well as C₂ alkanes in the stream 1714, may be cracked to C₂₊ alkenes (e.g., ethylene) in the PBC unit 1715 downstream of the OCM reactor 1710. The product stream is then directed to a condenser 1717, which removes water from the product stream. The product stream is then directed to a compression unit 1718 and subsequently another compression unit 1719. Methane from the compression unit 1719 is directed to the NG feed 1703 along stream 1720.

[00237] The OCM system 1702 can include one or more OCM reactor 1710. For example, the OCM reactor 1710 can be an OCM reactor train comprising multiple OCM reactors. The OCM system 1702 can include one or more PBC reactors 1715.

[00238] The compression units 1718 and 1719 can each be a multistage gas compression unit. Each stage of such multistage gas compression unit can be followed by cooling and liquid hydrocarbon and water removal.

Ethylene Plants

[00239] In an aspect, the present disclosure provides a method for producing C₂₊ compounds by performing an oxidative coupling of methane (OCM) reaction to produce an OCM effluent comprising methane (CH₄), hydrogen (H₂), carbon dioxide (CO₂), ethylene (C₂H₄) and C₂₊ compounds. The OCM effluent can be separated into a first stream comprising C₂₊ compounds and a second stream comprising CH₄, CO₂, and H₂. The second stream can be methanated to produce a first OCM reactor feed comprising additional CH₄ formed from the CO₂ and the H₂ in the second stream. A third stream can be methanated to produce a second OCM reactor feed comprising CH₄. The third stream can comprise CH₄ and H₂ from demethanizer off-gas from an ethylene cracker. The first and second OCM reactor feeds can then be provided to the OCM reaction.

[00240] In some embodiments, the second stream and the third stream are methanated in a single methanation reactor. The method can further comprise providing the first stream to the separation section of the ethylene cracker. The ethylene cracker can be an existing ethylene cracker, which may be present prior to retrofitting with an OCM reactor and additional unit operations. The separation section may be evaluated for available capacity to process the additional feed. In some cases, the cracker operation can be modified to operate at a lower severity, hence making some additional capacity available in the existing separation section, especially C₁, C₂ and C₃ area. In some cases, the first stream is provided to a gas compressor or a

fractionation unit of the ethylene cracker. In some embodiments, the third stream is the overhead stream of a demethanizer of the ethylene cracker. In some cases, separation is performed in a pressure swing adsorption (PSA) unit. In some embodiments, the OCM effluent is compressed prior to separating in the PSA unit. In some cases, the separation section also includes, but is not limited to, a CO₂ removal system, which typically includes an amine system or a caustic tower and/ or dryers to remove water from the OCM effluent.

[00241] The method can further comprise feeding oxygen (O₂) to the OCM reaction. In some cases, the OCM effluent further comprises carbon monoxide (CO) and the CO is converted into CH₄ in operation (c). In some instances, the third stream further comprises CO₂ or CO. The OCM reaction can further react additional CH₄ from external supply of natural gas. In some embodiments, the third stream further comprises CH₄.

[00242] In another aspect, the present disclosure provides an oxidative coupling of methane (OCM) system for production of C₂₊ compounds. The system can comprise an OCM subsystem that (i) takes as input a feed stream comprising methane (CH₄) and a feed stream comprising an oxidizing agent, and (ii) generates a product stream comprising C₂₊ compounds from the CH₄ and the oxidizing agent. The system can further comprise a separation subsystem fluidically coupled to the OCM subsystem that separates the product stream into (i) a first stream comprising C₂₊ compounds and (ii) a second stream comprising methane (CH₄) hydrogen (H₂) and carbon dioxide (CO₂) and/or carbon monoxide (CO). The system can further comprise a methanation subsystem fluidically coupled to the second stream and to the OCM subsystem, wherein the methanation subsystem converts H₂ and CO₂ and/or CO into CH₄. The system can further comprise an ethylene cracker subsystem fluidically coupled to the methanation subsystem that provides additional CH₄ and H₂ to the methanation subsystem.

[00243] In some embodiments, the methanation subsystem provides CH₄ for the OCM subsystem. The additional CH₄ and H₂ can be derived from the demethanizer overhead of the ethylene cracker subsystem. The first stream comprising C₂₊ components can be fluidically coupled to the ethylene cracker subsystem. The first stream can be fractionated in the ethylene cracker subsystem. The separation subsystem can include a pressure swing adsorption (PSA) unit.

[00244] In some instances, the OCM subsystem is supplied additional CH₄ from a natural gas feed stream. In some cases, the oxidizing agent is O₂ (e.g., provided by air from an air separation unit or any other type of oxygen concentration unit).

[00245] In some embodiments, the OCM subsystem comprises at least one OCM reactor. In some instances, the OCM subsystem comprises at least one post-bed cracking unit within the

at least one OCM reactor or downstream of the at least one OCM reactor, which post-bed cracking unit is configured to convert at least a portion of alkanes in the product stream to alkenes. In some cases, the reactor is adiabatic. In some instances, the post-bed cracking unit uses ethane and propane recycle streams from the existing Ethylene cracker subsystem to achieve conversion to ethylene. In some cases, the recycle streams are routed to the cracking furnaces to completely crack the recycle streams.

[00246] FIG. 18 shows an example of an OCM process integrated with an existing ethylene cracker. The OCM reactor 1800 takes in methane and oxygen 1802 and produces an OCM effluent 1805 having CO₂, CH₄ and C₂H₄, in some cases amongst other components, such as H₂ and CO. The OCM reaction can be exothermic and can produce steam 1807. The OCM effluent 1805 can be compressed in a compressor 1810 and fed into a pressure swing adsorption (PSA) unit 1815.

[00247] The PSA unit can produce an overhead stream 1820 that can include H₂, CH₄, CO₂ and CO. The overhead stream can be fed into a methanation subsystem 1822 (e.g., methanation reactor) to provide methane for the OCM reactor 1800. Additional methane can be provided by way of a natural gas stream 1824.

[00248] The process of FIG. 18 further includes an existing ethylene cracker 1830 with a demethanizer off gas stream. Demethanizer off gas from the existing ethylene cracker 1830 subsystem can supply additional CH₄ and H₂ that may be required for methanation. Methane generated in the ethylene cracker 1830 can be returned to the OCM reactor 1800 via stream 1826.

[00249] Heavier components can exit the PSA separately 1825 and include ethane, ethylene and C₃₊ compounds, which can be fractionated using existing separations capacity in the ethylene cracker 1830. The heavy components can be processed in the fractionation towers of the ethylene cracker, optionally first being compressed in the existing process gas compressor of the ethylene cracker. In some cases, the heavy components stream can be routed to the CO₂ removal unit of the existing ethylene cracker subsystem to meet the CO₂ specification.

[00250] In processes, systems, and methods of the present disclosure, a Fischer-Tropsch (F-T) reactor can be used to replace a methanation reactor, for example in a methane recycle stream. CO and H₂, such as that found in a methane recycle stream, can be converted to a variety of paraffinic linear hydrocarbons, including methane, in an F-T reaction. Higher levels of linear hydrocarbons, such as ethane, can improve OCM process efficiency and economics. For example, effluent from an OCM reactor can be directed through a cooling/compression system and other processes before removal of a recycle stream in a de-methanizer. The recycle stream

can comprise CH₄, CO, and H₂, and can be directed into an F-T reactor. The F-T reactor can produce CH₄ and C₂₊ paraffins for recycling into the OCM reactor. A range of catalysts, including any suitable F-T catalyst, can be employed. Reactor designs, including those discussed in the present disclosure, can be employed. F-T reactor operation conditions, including temperature and pressure, can be optimized. This approach can reduce H₂ consumption compared to a methanation reactor.

[00251] The combination of a new OCM unit and an existing ethylene cracker is expected to have certain synergistic benefits. In some cases, prior to retrofit of an ethylene cracker with OCM, the entire overhead from the existing demethanizer was being used as fuel gas, and can now be available as one of the feeds to the methanation unit. In some cases, the demethanizer overhead off-gas comprises up to 95% methane which can be converted to Ethylene in the OCM reactor, hence increasing the total ethylene capacity. In some cases, the hydrogen content in the existing demethanizer overhead is substantial, and may be enough to meet the hydrogen requirement of the methanation unit.

[00252] In some cases, retrofitting an ethylene cracker with OCM reduces (or allows for reduction of) the severity of cracking in the existing cracker, enabling value addition by increasing the production of pyrolysis gasoline components in the cracker effluent, as the OCM reactor produces the ethylene needed to achieve the total system capacity. The cracker can then be operated on high propylene mode to produce more propylene and at the same time meeting the ethylene production rate by the new OCM unit. This retrofit can result in greater flexibility for the ethylene producer with respect to the existing cracker operation.

[00253] In some instances, the overall carbon efficiency is increased as the methane and hydrogen from the existing demethanizer off-gases can be utilized to convert the carbon dioxide and carbon monoxide to methane, which is fed to the OCM reactor.

[00254] In some instances, ethane and/or propane recycle streams from the existing cracker can be routed to the OCM unit (e.g., instead of the cracking furnaces). These recycle streams are typically routed to the cracking furnaces where they are “cracked to extinction.” The advantage over routing the recycle streams to OCM over the cracking furnace is higher selectivity to ethylene in the OCM process.

[00255] Purge gas from the OCM-methanation system can (at least partially) meet the fuel gas requirements of the existing cracker complex. In some cases, the fuel requirements are met by the existing demethanizer off-gas.

[00256] Additional capacity (e.g., for ethylene, propylene or pyrolysis gasoline components) can be gained by integrating an OCM unit and supplying additional natural gas

feed to the OCM reactor unit which will increase ethylene production, and the existing cracker can be operated at a reduced severity and/or increased throughput to produce more olefin and/or pyrolysis gas components. Additional fractionation equipment can be used to recover ethylene, for example, if the existing separations section does not have sufficient capacity, or if the existing cracker is operated at a substantially higher throughput than it was built for.

[00257] With regard to the present disclosure allowing for reduced severity of cracking, a cracking furnace can thermally crack the hydrocarbon feed comprising of a full range naphtha, light naphtha, ethane, propane or LPG feed to produce ethylene and propylene, along with pyrolysis gas oil, fuel oil and a methane-rich off-gas. The product mix can depend on the feed composition and the process operating conditions. Important process variables can include steam to hydrocarbon ratio (which can vary from 0.3 for ethane and propane feed, and 0.5 for naphtha feed and as high as 0.7 for light vacuum gas oil feeds), temperature (which can vary from 750-850°C), and the residence time (which can vary, typically in the range of 0.1 to 0.5 seconds). The cracking reaction is favored by low hydrocarbon partial pressure and hence steam can be added to reduce the hydrocarbon partial pressure. Higher steam to hydrocarbon ratio can improve selectivity at the cost of more energy. Severity is the extent or the depth of cracking, with higher severity achieved by operating the cracking furnace at a higher temperature. High severity operation yields more ethylene, and also results in higher rate of coke formation and hence a reduced time between decoking. As the cracking severity is reduced, the yield of ethylene and lighter components decreases and the yield of propylene and heavier components increases. For liquid feeds, severity is measured as the weight ratio of propylene to ethylene in the cracked gases. For gaseous feeds, severity is measured as percentage conversion (mass) of the key components (e.g., percentage disappearance of ethane or propane). The cracking furnace can be operated to maximize ethylene or propylene, depending on the economics and demand. Another process variable in cracker operation is the coil outlet pressure (COP) which is the pressure at the outlet of furnace coils. Low absolute pressure improves selectivity and the pressure is usually kept at about 30 psia for gaseous feeds and 25 psia for liquid feeds.

[00258] For example, the influence of pyrolysis temperature can be isolated by keeping the residence time and steam content constant. As the furnace exit temperature increase, ethylene yield also rises, while yields of propylene and pyrolysis gasoline decrease. At very high temperature, residence time can become the controlling factor. Highest ethylene yields can be achieved by operating at high severity (e.g., about 850 °C), with residence time ranging from 0.2 to 0.4 seconds.

[00259] There are numerous ways that the synergies between an OCM unit and an existing ethylene cracker can be realized. Depending on the desired product cut, the OCM unit can significantly increase the flexibility of operation and provide additional capacity gain at a lower incremental cost. Based on the existing plant operation, the desired product spectrum and natural gas availability, integrating an OCM unit with an existing ethylene plant (e.g., naphtha cracker or gas cracker) can offer considerable benefits including:

[00260] In some cases, natural gas is more economical than naphtha for converting to ethylene and propylene. Integration with OCM can provide the plant the flexibility to operate with a different feedstock at desired severity. In some cases, the integrating with OCM gives an operational flexibility, to operate at the desired throughput and feed mix depending on the option that makes best economic sense for the operator.

[00261] Installing more cracking capacity to an existing cracker can require the entire train of process units to be debottlenecked (e.g., quench, gasoline fractionation, compression, refrigeration, and recovery unit). In contrast, gaining capacity by integrating with OCM can result in minimum impact on the existing process unit debottlenecking. For example, since the OCM reaction is highly selective to ethylene (e.g., greater than 50%), there can be a minimum impact on the rest of the system (e.g., especially the hot section and C₃₊ handling unit).

[00262] The OCM reaction is highly exothermic and the high heat of reaction can be put to multiple uses. It may be used to crack more ethane (e.g., from the ethane and propane recycle streams of the existing cracker) to further improve conversion to ethylene. The heat of reaction may also be used to generate steam which can be used to meet process requirements or generate power. The OCM unit can be a net exporter of steam and/ or power.

Pyrolysis process retrofit with OCM

[00263] In an OCM process, methane (CH₄) reacts with an oxidizing agent over a catalyst bed to generate C₂₊ compounds. The OCM process produces olefins, such as ethylene, and can add to or replace olefin production from a pyrolysis process (e.g., ethane cracking or naphtha cracking). In some cases, a low price natural gas feedstock (used by the OCM process) makes the retrofit to the cracker (which uses expensive feedstock such as naphtha or ethane) an attractive and economical process.

[00264] **FIG. 19** illustrates how a cracker **1932** can be retrofitted (integrated) with the OCM process. Various unit operations between the blocks and columns are not shown for the purposes of simplification of the drawing. With reference to **FIG. 19**, the integrated process uses OCM effluent **1900** from an OCM reactor **1902** (containing C₁, and C₂₊ type hydrocarbons) that utilize a separation train downstream of the cracker **1932** to produce olefins **1904**, such as

ethylene and propylene. Natural gas **1934** is fed into the OCM reactor, along with a source of O₂ **1936** (e.g., air or enriched oxygen). The natural gas can be de-sulfurized in a sulfur removal unit **1938**.

[00265] A lean oil absorber **1906** using light or heavy pyrolysis gas from the cracker, or any oil stream containing hydrocarbons in the C₅ to C₁₀ range from refining and/or natural gas processing plants, can be used to separate the C₁ from the C₂₊ hydrocarbons and uses all or some of the unit operations downstream of the quench tower **1908** of a typical cracker for the cleaning and separations of the hydrocarbons.

[00266] The OCM effluent to the process gas compressor (PGC) **1910** compresses the gas to a pressure between 200-800 psia. Water present in the OCM effluent can be removed. A mole sieve drier is a non-limiting example of a process that may remove water from the system, but any conventional water removal system can be used in this system. The effluent is then cooled to between 50 °F and -80 °F, in some cases between -20 °F to -60 °F, (depending on C₂₊ purity required by the cracker) and sent to lean oil absorber column **1906**.

[00267] The lean oil absorber **1906** can run with both a light pyrolysis gas (such as C₅₊ pyrolysis gas) obtained from the quench tower of a typical cracker **1912** and also a heavy pyrolysis gas (such as C₇₊ pyrolysis gas) **1914** typically obtained from the heavies fractionator, such as a de-butanizer, de-pentanizer, or gasoline stripper of a cracker, or gasoline from the aromatics extraction plant (either raffinate/light pyrolysis gasoline or the heavy pyrolysis gasoline stream).

[00268] The absorber can operate with 40-100 stages, 200-800 psia, and -80 °F to 50 °F, providing C₂ recovery of 75%-100%. The ratio of the lbs of C₁/lb ethylene from the bottoms of the absorber can be between 1.0-3.0 lbs C₁/lb ethylene depending on the conditions used in the absorber. The lean oil losses in the process are as low as 0.0004 – 0.001 wt% of lean oil. The ratio of lean oil to OCM effluent is between 0.5 – 5.5 on a mass basis.

[00269] The rich C₂₊ stream can then be sent to the PGC of the cracker **1916**, treated and separated to produce olefins, such as ethylene. For example, the rich oil can be fed to the compressor's third stage discharge drum, where it can flash lights into the fourth stage suction, while the heavies can be sent to the second stage suction for further recovery of lights. Eventually the oil can be recovered in the Quench tower **1980** and sent back to the lean oil absorber. Alternatively, the rich oil can be sent to a new stripping column, with the lights then sent to the appropriate suction drum of the PGC.

[00270] If the constraints of the cracker are such that a purer C₂ spec is required or if the demethanizer of the cracker is constrained by methane removal capacity, a C₁/C₂ fractionator

1918 can be added to recover 60-100% of the methane from the overhead of the fractionator with a much purer C₂₊ stream sent to either the demethanizer or the deethanizer of the cracker.

The C₂₊ can then be separated in the separations train to produce olefins and the C₁ sent back to the OCM as recycle C₁ **1920**. Depending on the CO₂ concentration from the C₁/C₂ fractionator, a caustic wash can be used or the C₂₊ sent to the gas treating section for CO₂ removal.

[00271] The C₁/C₂ fractionator can run between 200-800 psia, and provide 99.0 - 99.9% recovery of the methane from the C₂₊ stream. This can be sent to gas treating **1922** before separations **1924** and/or the demethanizer and/or the deethanizer in the cracker depending on the concentration of CO₂ and C₁ in the C₂₊ stream from the fractionator.

[00272] Refrigeration power can also be recovered from the C₁ recycle stream to the OCM depending on the conditions at which the absorber and OCM are running. Refrigeration power anywhere between 0.1 kilowatts (KW)/pound ethylene to 1 KW/pound ethylene can be recovered.

[00273] The CO₂ **1926** from the overhead of either the absorber or the fractionator can be sent to a methanation unit **1928** in which the CO₂ and CO react with the H₂ in the presence of a catalyst to form CH₄ and recycled back to the OCM reactor.

[00274] Natural gas produced in the demethanizer of the cracker train can be sent back to the OCM unit to the methanation section. The H₂ content in the recycle stream can be methanated in the presence of CO₂ and CO in the methanation reactor and sent to the OCM reactor as feed natural gas.

[00275] The OCM process also produces a purge stream **1930**, with a heating value in the range of 800 BTU/SCF to 1000 BTU/SCF that can be used as fuel gas, make-up or otherwise. Additional natural gas may also be fed to the cracker furnace through streams **1920** before methanation of the C₁ recycle, or stream **1944** after methanation (such as, e.g., depending on cracker requirements), to provide fuel gas since the fuel oil is utilized in a more efficient manner of producing olefins. The present example shows how olefins **1904** can be produced from both natural gas **1934** and cracker feed **1940** (e.g., as shown in **FIG. 19**).

[00276] In some cases, the cracker **1932** generates ethane in addition to olefins. The ethane can be recycled to an ethane conversion section of the OCM reactor **1902** for conversion to olefins.

Control Systems

[00277] The present disclosure provides computer control systems that can be employed to regulate or otherwise control OCM methods and systems provided herein. A control system of the present disclosure can be programmed to control process parameters to, for example,

effect a given product distribution, such as a higher concentration of alkenes as compared to alkanes in a product stream out of an OCM reactor.

[00278] FIG. 20 shows a computer system **2001** that is programmed or otherwise configured to regulate OCM reactions, such as regulate fluid properties (e.g., temperature, pressure and stream flow rate(s)), mixing, heat exchange and OCM reactions. The computer system **2001** can regulate, for example, fluid stream (“stream”) flow rates, stream temperatures, stream pressures, OCM reactor temperature, OCM reactor pressure, the quantity of products that are recycled, and the quantity of a first stream (e.g., methane stream) that is mixed with a second stream (e.g., air stream).

[00279] The computer system **2001** includes a central processing unit (CPU, also “processor” and “computer processor” herein) **2005**, which can be a single core or multi core processor, or a plurality of processors for parallel processing. The computer system **2001** also includes memory or memory location **2010** (e.g., random-access memory, read-only memory, flash memory), electronic storage unit **2015** (e.g., hard disk), communication interface **2020** (e.g., network adapter) for communicating with one or more other systems, and peripheral devices **2025**, such as cache, other memory, data storage and/or electronic display adapters. The memory **2010**, storage unit **2015**, interface **2020** and peripheral devices **2025** are in communication with the CPU **2005** through a communication bus (solid lines), such as a motherboard. The storage unit **2015** can be a data storage unit (or data repository) for storing data.

[00280] The CPU **2005** can execute a sequence of machine-readable instructions, which can be embodied in a program or software. The instructions may be stored in a memory location, such as the memory **2010**. Examples of operations performed by the CPU **2005** can include fetch, decode, execute, and writeback.

[00281] The storage unit **2015** can store files, such as drivers, libraries and saved programs. The storage unit **2015** can store programs generated by users and recorded sessions, as well as output(s) associated with the programs. The storage unit **2015** can store user data, e.g., user preferences and user programs. The computer system **2001** in some cases can include one or more additional data storage units that are external to the computer system **2001**, such as located on a remote server that is in communication with the computer system **2001** through an intranet or the Internet.

[00282] The computer system **2001** can be in communication with an OCM system **2030**, including an OCM reactor and various process elements. Such process elements can include sensors, flow regulators (e.g., valves), and pumping systems that are configured to direct a fluid.

[00283] Methods as described herein can be implemented by way of machine (e.g., computer processor) executable code stored on an electronic storage location of the computer system **2001**, such as, for example, on the memory **2010** or electronic storage unit **2015**. The machine executable or machine readable code can be provided in the form of software. During use, the code can be executed by the processor **2005**. In some cases, the code can be retrieved from the storage unit **2015** and stored on the memory **2010** for ready access by the processor **2005**. In some situations, the electronic storage unit **2015** can be precluded, and machine-executable instructions are stored on memory **2010**.

[00284] The code can be pre-compiled and configured for use with a machine have a processor adapted to execute the code, or can be compiled during runtime. The code can be supplied in a programming language that can be selected to enable the code to execute in a pre-compiled or as-compiled fashion.

[00285] Aspects of the systems and methods provided herein, such as the computer system **2001**, can be embodied in programming. Various aspects of the technology may be thought of as “products” or “articles of manufacture” typically in the form of machine (or processor) executable code and/or associated data that is carried on or embodied in a type of machine readable medium. Machine-executable code can be stored on an electronic storage unit, such memory (e.g., read-only memory, random-access memory, flash memory) or a hard disk. “Storage” type media can include any or all of the tangible memory of the computers, processors or the like, or associated modules thereof, such as various semiconductor memories, tape drives, disk drives and the like, which may provide non-transitory storage at any time for the software programming. All or portions of the software may at times be communicated through the Internet or various other telecommunication networks. Such communications, for example, may enable loading of the software from one computer or processor into another, for example, from a management server or host computer into the computer platform of an application server. Thus, another type of media that may bear the software elements includes optical, electrical and electromagnetic waves, such as used across physical interfaces between local devices, through wired and optical landline networks and over various air-links. The physical elements that carry such waves, such as wired or wireless links, optical links or the like, also may be considered as media bearing the software. As used herein, unless restricted to non-transitory, tangible “storage” media, terms such as computer or machine “readable medium” refer to any medium that participates in providing instructions to a processor for execution.

[00286] Hence, a machine readable medium, such as computer-executable code, may take many forms, including but not limited to, a tangible storage medium, a carrier wave medium or

physical transmission medium. Non-volatile storage media include, for example, optical or magnetic disks, such as any of the storage devices in any computer(s) or the like, such as may be used to implement the databases, etc. shown in the drawings. Volatile storage media include dynamic memory, such as main memory of such a computer platform. Tangible transmission media include coaxial cables; copper wire and fiber optics, including the wires that comprise a bus within a computer system. Carrier-wave transmission media may take the form of electric or electromagnetic signals, or acoustic or light waves such as those generated during radio frequency (RF) and infrared (IR) data communications. Common forms of computer-readable media therefore include for example: a floppy disk, a flexible disk, hard disk, magnetic tape, any other magnetic medium, a CD-ROM, DVD or DVD-ROM, any other optical medium, punch cards paper tape, any other physical storage medium with patterns of holes, a RAM, a ROM, a PROM and EPROM, a FLASH-EPROM, any other memory chip or cartridge, a carrier wave transporting data or instructions, cables or links transporting such a carrier wave, or any other medium from which a computer may read programming code and/or data. Many of these forms of computer readable media may be involved in carrying one or more sequences of one or more instructions to a processor for execution.

EXAMPLES

[00287] Below are various non-limiting examples of uses and implementations of OCM catalysts and systems of the present disclosure.

EXAMPLE 1: Implementation of OCM

[00288] About 1,000,000 metric tons/year of polymer grade ethylene is produced via the oxidative coupling of methane (OCM). The OCM reactor comprises a 2-stage adiabatic axial fixed bed that utilizes an OCM catalyst (e.g., nanowire catalyst) to convert methane and high purity oxygen to ethylene. The methane feed to the OCM reactor is the recycle stream from a downstream demethanizer over-head supplemented by CO and CO₂ conversion to methane in a two-stage methanation reactor. The hot OCM effluent from a second stage of the reactor effluent is mixed with heated recycle ethane from a downstream C₂ splitter and cracked to convert ethane primarily into ethylene. Hot reactor effluent is used to heat OCM reactor feed, generate high-pressure steam and heat process condensate. Cold reactor effluent is compressed and mixed with sulfur-free pipeline natural gas and treated to remove CO₂ and H₂O prior to cryogenic separations. The treated process gas is fed to a demethanizer column to recover about 99% of ethylene as column bottoms stream. Demethanizer bottoms steam is separated in deethanizer column to separate C₂'s from C₃₊ components. Deethanizer column overhead is first treated in

selective hydrogenation unit to convert acetylene into ethylene and ethane using H₂ from a Pressure Swing Adsorption (PSA) Unit. The resulting stream is separated in a C₂ splitter unit to separate ethylene from ethane. Deethanizer bottoms stream is sent to a De-propanizer to obtain Refinery Grade Propylene (RGP) and mixed C₄₊ stream, both which can be sold for credit. Ethane product stream from C₂ splitter bottoms is recycled to second stage of the OCM reactor to complete extinction. Polymer grade ethylene product (99.96 wt% ethylene) obtained from the C₂ splitter overhead is compressed to 1,000 psig and exported as vapor product. A stream factor of 0.95 is used (equal to an installed capacity of 1,059,000 metric tons/yr).

[00289] The OCM process generates superheated high pressure (~1500 psia) steam that is used to run process gas compressors, refrigeration compressors, ethylene heat pump / product compressors, and major pumps. The remainder of the steam and small portion of recycle methane (purge gas) can be exported to combined cycle/gas turbine system to generate power. The OCM process has an energy intensity of -0.89 MMBTU/MT ethylene, while the energy intensity of a comparably sized steam cracking of ethane process is about 31.89 MMBTU/MT.

[00290] The reactor consists of a 2-stage adiabatic axial fixed bed with intermediate heat recovery via high-pressure steam generation. The methane stream recycled from the demethanizer overhead becomes the main OCM reactor feed. In both stages high purity oxygen is mixed with the hydrocarbon stream in a proportion of approximately 1:10 on a molar basis to achieve the optimal O₂-limited composition for the OCM reaction.

[00291] In the OCM reactor, the catalyst enables the partial and highly selective conversion of methane to, primarily, ethylene and ethane, with minor amounts of propylene and propane. Non-selective pathways include high temperature hydrocarbon reactions, such as combustion, reforming and shift. The second stage of the reactor is designed to accommodate an ethane conversion zone immediately downstream of the catalytic bed. Ethane recycled from the deethanizer and, optionally, additional fresh ethane feed are injected into this reactor section where ethane undergoes highly selective adiabatic thermal de-hydrogenation to ethylene.

[00292] The OCM reactor effluent flows through a series of heat exchangers to achieve optimal heat recovery and final condensation at ambient temperature, prior to being sent to the Process Gas Compressor (PGC). The natural gas feed stream is mixed with the OCM reactor effluent at the PGC delivery. Gas treating, including CO₂ removal and drying, follows the compression step. The product recovery train consists of a demethanizer, deethanizer, acetylene converter and C₂ splitter configuration where the refrigeration and heat integration scheme is designed to optimize heat recovery and minimize power consumption. The product streams comprise of polymer grade ethylene and a C₃₊ mixed stream, similar in composition to Refinery

Grade Propylene (RGP), which can be optionally further separated and purified. The C₁ recycle stream leaving the demethanizer head is sent to a conventional methanation unit where all CO and a portion of the CO₂ product react with hydrogen to form methane. The integration of the methanation unit into the overall process design is instrumental to maximize the carbon efficiency of the OCM technology.

[00293] The OCM process design is energy neutral. The OCM reaction heat is utilized to provide mechanical power to the rotating units required for compression and pumping. The OCM process gets pure oxygen from an adjacent Air Separation Unit (ASU) which also houses a Gas Turbine Combined Cycle (GTCC). The GTCC unit is fed with the purge gas extracted from the demethanizer overhead and provides all the mechanical power and steam required by the ASU.

[00294] The final products are 1,000,000 metric tons per annum of polymer grade ethylene and 88,530 metric tons per annum of C₃₊ hydrocarbons. The C₃₊ hydrocarbons are sent to a depropanizer to obtain refinery grade propylene (65% propylene) as distillate.

EXAMPLE 2: Design basis of OCM Implementation

[00295] The feedstock streams can include a natural gas stream, which supplies the process with the methane and ethane for conversion into ethylene, an oxygen stream, to be supplied by the dedicated Air Separation Unit (ASU) section, an optional ethane stream, which provides extra ethane (in addition to that contained in the natural gas feed) for conversion into ethylene.

[00296] As shown in **FIG. 21**, the ethylene product plant comprises four sections including an OCM reaction section **2100** (comprising methanation, OCM and heat recover), a process gas compression and treating section **2105** (comprising PGC, CO₂ removal and drying), a product separation and recovery section **2110** (comprising demethanizer, deethanizer, C₂ splitter and de-propanizer) and a refrigeration system **2115** (comprising propylene and ethylene). The process takes in natural gas **2120**, which can be desulfurized. The process can take in oxygen **2125** from an air separation unit. Ethane can be added externally **2130** or as part of a C₂ recycle **2135**. The purge gas **2140** can contain C₁ compounds and can be recycled **2145**. Products can include ethylene **2150**, C₄₊ compounds **2155** and RGP **2160**.

[00297] Unlike at least some syngas based production processes, the present process is flexible in terms of quality and composition required for the natural gas stream. For example, the process can handle an extremely wide range of natural gas liquids concentration, in particular ethane. None of the typical contaminants present in natural gas, including sulfur, represents a poison for the OCM catalyst. Prior to entering the process, the natural gas feed is treated for

sulfur removal in order to prevent contamination of the process outputs and sulfur accumulation in the process. The desulfurization scheme adopted is hydrotreating in a Co/Mo catalyst bed followed by adsorption on a zinc oxide bed. Depending on the actual sulfur content and composition, the adsorption bed may be the only operation. Alternatively other conventional methods of sulfur removal may be used.

[00298] The source of the oxygen for the OCM reaction can be air or pure oxygen or any enriched air stream. The presence and concentration of nitrogen may not impact the performances of the OCM reactor system. However, under certain conditions, utilizing pure oxygen as delivered by a conventional Air Separation Unit may minimize the overall process production costs at large scale. Alternatively, enriched air produced via a PSA or air sourced via a compressor may provide the optimal economic solution under other large scale applications.

[00299] The OCM reactor has the capability of efficiently processing separate streams of methane and ethane. In the process, the methane stream comes from the demethanizer overhead while the ethane stream, which includes both the unconverted ethane and the ethane contained in the natural gas feed, comes from the deethanizer bottom. Depending on the actual ethane content in natural gas there may be additional ethane processing capacity available in the OCM reactor, which can be saturated with a fresh ethane feed directly mixed with the ethane recycle.

[00300] In the particular US Gulf Coast based case presented herein, the natural gas feed is relatively lean (~4.5 %mol ethane), thus additional ethane feed is considered to exploit the available reactor capacity and optimize the overall process economics.

[00301] A generic process layout for an ethylene plant based on information described in U.S. Patent Publication No. 2014/0012053 and PCT Patent Application No. US/2013/042480, each of which is herein incorporated by reference in its entirety. The process configurations presented herein are illustrative of a commercial system designed to produce high purity (e.g., 99.96 wt% purity) ethylene via oxidative coupling of methane.

[00302] As described in Example 1, the plant is sized to produce at least 1,000,000 metric ton/year (2,214 million lb/yr) of polymer grade ethylene at an on-stream factor of 0.95. Hence, the annual installed capacity is equivalent to 1,059,000 metric t/year (2,330 million lb/yr). The plant also produces 61,185 metric ton/year of refinery grade (65%) propylene and 27,345 metric ton/year of C₄₊ compounds. The reactor system is a 2-stage adiabatic axial fixed bed with intermediate heat recovery via high pressure steam generation; OCM nanowire catalyst with bed height = 8.3 ft.; 12" refractory lining; 2nd stage bottom section used for ethane cracking; and a 2-stage adiabatic methanation unit to convert CO and CO₂ recycle into methane. The feedstock is pipeline natural gas, 99.5% oxygen (fed in 1:10 molar basis with hydrocarbon stream), and

make-up ethane. The operating conditions include OCM reactor inlet conditions: 540°C (1004°F), 131 psia; OCM reactor exit temperature: 830°C (1525°F); and methanation reactor inlet conditions: 200°C (392°F), 161 psia. The overall conversion is 21.5%, which includes conversion of methane and ethane to all reaction products across the OCM reactor. The carbon efficiency is 71% for the ISBL process (specifies carbon utilization for all ISBL units) and 64% overall (includes energy consumption to run OSBL units (mainly ASU)). The selectivity for each reaction product across the OCM reactor is: 55.9% for C₂H₄; 2.2% for C₃H₆; 9.7% for CO; 31.3% for CO₂; and 0.9% for others.

EXAMPLE 3: Catalyst preparation and catalyst life

[00303] The catalyst is made according to U.S. patent application nos. 13/115,082, 13/479,767, 13/689,514 13/757,036 and 13/689,611, and PCT/US2014/028040 filed on March 14, 2014 each of which is entirely incorporated herein by reference. The catalyst is based upon mixed metal oxide catalysts. In some cases, the mixed metal oxide catalysts are comprised of nanowires, mixtures of nanowires and bulk metal oxides, or bulk catalysts. The OCM catalysts can be synthesized via a reaction similar to a standard co-precipitation reaction that takes place in an aqueous solution. The catalysts are then filtered out of the solution, and the resulting solids are calcined.

[00304] In order to produce a commercial catalyst, the calcined powder is then mixed with catalyst diluents and binders and formed into commercial forms. Catalyst forming tools are then used to form the combined powder, diluents, and binders into solid cylinders (or other shapes, such as spheres, rings, etc.) with the requisite strength and performance requirements. See, e.g., WO2013177461, which is entirely incorporated herein by reference. Such forming can take place via extrusion or tableting or other conventional catalyst forming techniques. **FIG. 22** shows an image of the formed cylindrical commercial OCM catalyst. **FIG. 23** and **FIG. 24** show Scanning Electron Microscope images of a magnified portion of the commercial catalyst. **FIG. 23** and **FIG. 24** show the entire, formed catalyst with nanowires incorporated along with diluents and binders. The white bar in each of the figures designates a scale bar of 5 micrometers (microns).

[00305] Under the operating conditions described within this application, an OCM catalyst is stable, with a minimum lifetime of at least 1 year, 2 years, 3 years, 4 years, 5 years, 6 years, 7 years, 8 years, 9 years, 10 years, or 20 years. An OCM catalyst can be regenerated in-situ or regenerated ex-situ. Alternatively, instead of regeneration, an OCM catalyst can be unloaded and returned to the catalyst manufacturer. There, it can be recycled to reclaim its constituent elemental components, or, alternatively, disposed of.

EXAMPLE 4: OCM reactors and reaction systems

[00306] The OCM reactor contains two reaction zones. The entire reactor is a refractory-lined adiabatic reactor. The first reaction zone contains a fixed OCM catalyst bed, to convert methane into ethylene. This is called the methane conversion zone. In the lower section of the reactor, ethane is injected to homogeneously convert ethane to ethylene utilizing the heat generated during methane conversion. This is called the ethane conversion zone. The introduction of reactants into the OCM reactor system is achieved using, extremely low residence time gas mixers. This allows the reactants to be introduced at elevated temperatures, without participating in non-selective side reactions.

[00307] In the adiabatic OCM reactor system, the temperature is allowed to rise within a reactor stage through the catalytic bed (methane conversion zone), from approximately 460°C, 470°C, 480°C, 490°C, 500°C, 510°C, 520°C, 530°C, 540°C, 550°C, 560°C, 570°C, 580°C, 590°C, or 600°C at the inlet to about 850°C, 860°C, 870°C, 880°C, 890°C, 900°C, 910°C, 920°C, 930°C at the outlet of the bed. Ethane at a lower inlet temperature (about 400°C-500°C) is injected into the ethane conversion zone to allow for additional non-oxidative dehydrogenation to take place thereby cooling the reactor effluent. A representative temperature profile of the entire reactor is shown in **FIG. 25**. The reactor has a methane conversion section (e.g., for OCM) and an ethane conversion section (e.g., for conversion of ethane to ethylene).

[00308] In some cases, performance of the process in terms of overall carbon efficiency is higher than that of the OCM reactor alone. The higher carbon efficiency derives from the presence of the catalytic methanation step, which converts all CO and a portion of the CO₂ product back to methane by utilizing the hydrogen generated in the thermal ethane conversion zone of the OCM reactor.

[00309] The methanation unit is a 2-stage adiabatic reaction system, which adopts the same or similar process technology used for Synthetic Natural Gas (SNG) production from syngas. The methanation section is designed to maximize hydrogen consumption and, thus, CO and CO₂ recovery to methane. Alternative process configurations may include the use of an isothermal reactor in place of the 2-stage adiabatic system.

[00310] The design basis also illustrates the impact of the outside battery limits (OSBL) units (mainly the Air Separation Unit) on the overall carbon and energy balance. In the process the purge gas from the demethanizer overhead fuels the GTCC unit, which is used to provide the mechanical power required by the ASU and make the entire process energy neutral.

[00311] With reference to **FIGs. 26-31**, the OCM Reaction System includes two conversion steps: i) the 2-stage OCM Reactor (R-101A&B **2650** and R-102A&B **2651**) that

converts the methane and ethane recycle streams into ethylene; and ii) the 2-stage Methanation Reactor (R-103 **2652** & R-104 **2653**) that converts the CO and H₂ present in the methane recycle (and some additional CO₂) into methane. A series of feed-product economizers, steam generator and super-heater, BFW pre-heater and cooling water exchangers is also included in this process area to provide optimal heat recovery

[00312] The methane recycle feed stream **2621** coming from the Demethanizer head is first pre-heated to 116°C (240°F) in the cross exchanger (E-110) **2661** with the hot effluent from the 2nd stage of OCM reactor and then further heated to approximately 200°C (392°F) in the Methanator Feed / Product Exchanger (E-101) **2654**. This methane stream is then sent to 1st stage (R-103) **2652** of the methanation unit where CO is almost completely converted to methane in presence of an excess of hydrogen. Methanation is an exothermic reaction limited by equilibrium and it is carried out over a suitable hydrogenation catalyst in a fixed bed adiabatic reactor. R-103 **2652** effluent **2602** is cooled in E-101 **2654** against R-103 **2652** feed, mixed with additional CO₂ coming from CO₂ removal unit and then fed to the 2nd stage (R-104) **2653** of methanation. In R-104, H₂ is the limiting reactant and is almost completely converted in the reaction.

[00313] R-104 effluent **2603** is further pre-heated in the Hot Gas-Gas Exchanger (E-102) **2655** to achieve the OCM reactor inlet temperature of 540°C (1004°F). It is then fed to the 1st stage (R-101) **2650** of the OCM Reactor to undergo OCM conversion to ethylene. In R-101 **2650** the pre-heated methane feed stream is mixed with the part of the oxygen supplied by the Air Separation Unit **2605**. The mixed feed flows over the OCM catalytic bed and leaves R-101 **2650** at a temperature of approximately 830°C (1525°F). The reaction heat generated in the 1st stage is recovered in the steam generator (E-103) **2656** by generating high pressure (1500 psia) steam. The high pressure stream from E-103 **2656** is further superheated to 476°C (889°F) in exchanger E-104 **2657**.

[00314] R-101 **2650** effluent is then fed to the 2nd stage (R-102 A&B) **2651** of the OCM reactor. It is again mixed with oxygen and fed to the OCM catalyst to carry out the OCM reactions. The ethane feed stream **2606** comprising of the ethane recycle **2634** from the C₂ splitter bottoms and make-up ethane **2601** is first preheated in the Ethane Gas-Gas Exchanger (E-107 **2658**) and then injected into the bottom section of R-102 **2651** immediately downstream of the OCM catalytic bed to undergo thermal de-hydrogenation to ethylene.

[00315] R-102 **2651** effluent at approximately 830°C (1528°F) is sent to the Steam Generator and Super-Heater Unit, E-106 **2657**, respectively where the reaction heat generated in the 2nd stage is optimally recovered. The product stream leaving E-106 **2657** flows through the

Ethane and the Hot Gas-Gas Exchangers, prior to entering the Boiler Feed Water (BFW) Pre-Heater (E-108) **2659**. The low temperature fraction of the reaction heat is recovered first in the BFW Pre-Heater E-108 **2659** and then in the Steam Condensate Pre-Heater E-109 **2660**. The product gas leaving **2660** flows into the Cold Gas-Gas Exchanger (E-110) **2661** prior to injection into the Quench Tower- I (C-101) **2662**.

[00316] In the Quench Column (C-101) **2662**, the product gas is further cooled to ambient temperature and a significant portion of the water produced in the OCM reactors is condensed and separated as Process Condensates **2608**. The C-101 **2662** overhead gas stream **2607** is sent to Process Gas Compression and Treating.

EXAMPLE 5: OCM process gas compression and treating

[00317] The process gas compressor discharge pressure is set to 540 psia to maintain the downstream process gas circuit to a single train with column and vessel sizes limited to a maximum 25 feet diameter. However, the demethanizer can operate as low as 175 psia. This can significantly reduce process gas compression requirements, but requires parallel process gas treatment and demethanizer unit trains and larger propylene and ethylene refrigerant systems. All tradeoffs between capital expense (CAPEX) and operating expense (OPEX) are resolved in a manner that maximizes overall financial return.

[00318] Process gas is treated to remove carbon dioxide and water to 0.5 ppmv prior to cryogenic separations using a monoethanol amine-based unit followed by a two-stage caustic wash. Molecular sieve dryers are utilized to remove all moisture from the treated process gas.

[00319] With reference to **FIGs. 26-31**, the Process Gas Compression & Treating section is comprised of four main units: i) The 2-stage (K-201A&B **2665** and K-202 **2666**) Process Gas Compressors (PGC); ii) a natural gas desulfurization unit **2667**; iii) the CO₂ removal Unit **2668**, including an amine-based absorber and a caustic wash column (G-201); and iv) a drying unit based on molecular sieves absorption (M-201 A-C) **2669**.

[00320] Process gas from the Quench Column C-101 **2662** is compressed in the 2-stage PGC unit (K-201 **2665** & 202 **2666**) to a final pressure of 540 psia. The compressed process gas delivered by K-202 **2666** is mixed with the desulfurized natural gas feed stream **2615** and sent to the Amine system unit (G-201) **2668**. Pipeline natural gas is first sent through a knockout (KO) drum (V-201) **2670**, pre-heated to 260°C (500°F) in exchanger (E-201) **2671** against the hot desulfurization reactor (R-201) **2672** effluent **2615** and further heated to 316°C (600°F) in a process furnace (F-201) **2673** before entering R-201 **2672**. The reactor R-201 **2672** consists of two beds: the top bed consists of a standard Co/Mo catalyst to convert the sulfur species to H₂S

and a bottom ZnO bed to adsorb it. The treated natural gas is sent through a turboexpander (S-201) **2674** to recover some energy.

[00321] The rich amine stream leaving the amine absorber bottom is first flashed at an intermediate pressure in the CO₂ Flash Drum. The CO₂ vapors leaving flash drum **2617** are sent to the methanation unit, as described in the previous section. The liquid bottoms leaving flash drum are heated against the lean amine from the Amine Regeneration Columns in the Lean-Rich Solution Exchanger. Medium pressure steam is used to provide the necessary heat for the Regeneration Columns Reboilers. The Regeneration column overhead vapor is cooled and then washed with process water to remove any residual amines prior to CO₂ venting **2618** to atmosphere. The overhead process gas from the CO₂ Absorber is further treated in the Caustic Wash Column, which consists of two stages (rich and lean caustic wash), followed by water-wash stage. The treated process gas from Caustic Wash Column **2616** is cooled in exchangers, E-204 **2675** and E-205 **2676**, against the methane recycle **2623** and H₂ recycle **2624** streams from the demethanizer, respectively, and then separated in the Knock-Out Drum V-202 **2677**. The methane recycle streams after exchanging heat through E-204 **2675**, receives part of the H₂ recycle and the PSA purge stream **2631**, before being split into the purge gas stream **2620** and C₁ recycle stream **2621**. The purge gas can be sold for credit or alternatively sent to the Gas Turbine Combined Cycle (GTCC) unit housed in an adjacent Air Separation Unit (ASU) to generate mechanical power. Part of the H₂ recycle stream is sent to the PSA unit **2622** to recover hydrogen for NG desulfurization in R-201 **2672** and Acetylene dehydrogenation in R-301.

[00322] The process gas leaving V-202 **2677** is then fed to the Molecular Sieve Gas Dryers (M-201A-C) **2669** where all moisture present in the vapors is removed. The dried process gas is then routed to product separation and recovery.

EXAMPLE 6: OCM process gas separations

[00323] The cryogenic separation section of this example utilizes demethanizer and deethanizer technology, but refrigeration is supplemented by expansion-cooling of the olefin-rich process gas as explained in U.S. Patent Application No. 13/739,954, which is herein incorporated by reference in its entirety. By utilizing these methods, the amount of refrigeration provided by propylene and ethylene can be reduced, which provides substantial energy savings.

[00324] The treated process gas is separated through a demethanizer, deethanizer, ethylene fractionator (C₂ splitter) and de-propanizer. Treated process gas is cooled using the demethanizer unit overhead product streams and side reboiler and the remainder of the cooling duty is provided by propylene and ethylene refrigeration. The demethanizer recovers 99% of the contained ethylene. The bottoms of the demethanizer are sent to the deethanizer. The overall

heat integration scheme for the demethanizer cooling is an aspect of the present disclosure. It includes the adoption of a split vapor process scheme, where a portion of the demethanizer overhead vapor is compressed and then expanded to provide the necessary reflux to the demethanizer. The remaining vapor streams are sent to a turbo-expander to recover refrigeration value and then recycled to the OCM reactor.

[00325] The balance between the demethanizer operating pressure, the amount of cooling produced by the internal split vapor scheme and the amount of refrigeration provided by external units constitutes an area of optimization for the trade-off between CAPEX and OPEX. The deethanizer unit is a separation column designed for an ethane recovery of 99 mol%. Deethanizer unit bottoms stream is further fractionated in a de-propanizer to recover a Refinery Grade Propylene (RGP) product stream and a C₄ mix product stream.

[00326] The deethanizer overhead stream is treated for acetylene and fed to the C₂ splitter, a heat pumped fractionator system. The overhead vapor is compressed and used to provide hot vapor for the reboiler. Liquid from the reboiler is then used to provide refrigerant for the condenser. The C₂ splitter can have a few trays that serve as a pasteurizing section to remove most of the hydrogen or other inerts that enter the C₂ splitter unit from the acetylene converter. The C₂ splitter can recover 99% of the contained ethylene with a purity of 99.95 mol%. The bottoms product is ethane and is recycled back to ethane conversion section of the OCM reactor.

[00327] With reference to **FIGs. 26-31**, the process gas stream **2619** leaving the Gas Dryers M-201A-C **2669** is routed to the first cold box E-301 **2678** and cooled against a series of cold streams coming from the Demethanizer system and from the external refrigeration units. The cooled gas stream leaving E-301 **2678** is fed to the Demethanizer Column C-301 **2679**, where the C₂₊ compounds are separated from the lighter components of the process gas (primarily CH₄, CO and H₂). The Demethanizer Column overhead products **2624** and **2625** are re-heated against the Demethanizer Column feed and recycled to the OCM Reaction System.

[00328] The overhead reflux necessary for the proper operation of the Demethanizer Column C-301 **2679** is generated via a proprietary refrigeration process scheme, known as the Recycle Split Vapor Unit (G-301) **2680** that minimizes the need for external refrigeration input. The C-301 **2679** bottom stream **2626** consists of ethane, ethylene, acetylene and a small fraction (~5.4%) of heavier (C₃₊) components. This liquid stream is sent to the Deethanizer Column (C-302) **2681**. The Deethanizer Column (C-302) **2681** separates the C₃₊ components in the C-302 **2681** feed from the C₂ components with minimum loss of ethylene in the C₃₊ stream. C-302 **2681** bottoms stream **2627** represents the mixed C₃₊ product stream which is sent to a Depropanizer (C-304) **2682**. Refinery grade propylene (RGP) (~65% propene) is obtained as C-304 **2682**

distillate stream **2635** and is sent to the appropriate distribution system to obtain by-product credit. Similarly, C-304 **2682** bottoms stream **2636** contains a mixed C₄₊ stream that can be sold.

[00329] The C-302 **2681** overhead stream is cooled in a partial condenser (E-304) **2683** using propene refrigeration. Liquid condensate is sent as reflux to C-302 **2681**. C-302 **2681** overhead vapor product **2628** is then heated in E-302 **2684** and routed to a two-stage acetylene hydrogenation reactor R-301 **2685** where all acetylene is hydrogenated to ethylene and ethane.

[00330] A pressure swing adsorption (PSA) unit (G-302) **2686** is installed on a slip stream of the demethanizer overhead vapors to produce the high-purity hydrogen stream required by the acetylene hydrogenation reactor (R-301) **2685**. The acetylene reactor operates at low temperatures (100°F Start of run and 150 °F End of run) using a selective palladium catalyst to convert acetylene to ethylene and ethane. R-301 **2685** effluent **2632** is cooled and sent to the Ethylene Splitter (C-303) **2687**. C-303 **2687** produces a 99.96 wt% pure ethylene overhead product **2633** and a 99% pure ethane stream **2634** as bottoms. A cold box (E-306) **2688** serves as the C-303 **2687** condenser and reboiler. A heat pump compressor K-302 **2689** provides hot ethylene vapor to the C-303 reboiler after looping once through the condenser. The condensed ethylene liquid from the reboiler is used in the C-303 condenser.

[00331] The high-pressure ethylene product **2633** from K-302 **2689** is sent to the relevant distribution system. The C-303 bottoms **2634** are recycled to OCM reaction and injected into the 2nd stage R-102 **2651** of the OCM Reactor.

EXAMPLE 7: Refrigeration and steam generation

[00332] The system consists of propylene and ethylene refrigeration systems. Propylene refrigeration system is a three-stage refrigeration system, with three different coolant levels, as illustrated in **FIG. 30**. Additional utilities are shown in **FIG. 31**.

[00333] Evaporating ethylene from the propylene refrigeration cycle is used to condense the ethylene in the ethylene refrigeration cycle and provide refrigerant to the deethanizer overhead condenser (E-304 **2683**) and the demethanizer cold box (E-301 **2678**).

[00334] Ethylene refrigeration system is also a three-stage refrigeration system as illustrated in **FIG. 30**. This system provides refrigeration to the demethanizer cold box (E-301 **2678**) and to the Recycle Split Vapor Unit (RSV **2680**).

[00335] Superheated, high pressure (HP) steam (1500 psia, 889°F) generated by the OCM process is used to drive the process gas compressor, the demethanizer overhead compressor, the refrigeration compressors, the ethylene fractionator heat pump and product compressors, half of cooling water and boiler feed water pumps (in offsites), and is fed to medium pressure (MP, 165 psia) and low pressure (LP, 50 psia) reboilers after proper flashing and de-superheating. Any

remaining steam can be exported to the Gas Turbine Combined Cycle (GTCC) unit housed in an adjacent Air Separation Unit (ASU) that provides 99.5% O₂ for the OCM reaction. A purge gas stream is also sent to the GTCC unit to generate the mechanical power required by the ASU unit. In this review, excess steam and purge gas account for utility and by-product credit, respectively

EXAMPLE 8: Stream compositions

[00336] **Table 1** shows the total flow-rate and flow rates of selected molecular entities (e.g., Hydrogen and Argon) for select streams of the example process. Stream numbers correspond to those of **Examples 4-7** and **FIGs. 26-31**.

Table 1: Stream flow rates

Stream #	2001	2002	2003	2004	2005	2006	2007
Total (1000 lb/hr)	65.8	2694.7	2792.4	8304.9	843.6	209.0	3264.1
Methane	0.0	2320.7	2348.8	1909.0	0.0	0.0	1908.7
Ethylene	0.0	0.0	0.0	268.9	0.0	2.7	268.9
Ethane	62.0	2.5	2.5	102.7	0.0	202.6	102.8
Acetylene	0.0	0.0	0.0	3.7	0.0	0.0	3.7
Propene	0.0	0.0	0.0	10.4	0.0	0.0	10.4
Propane	3.8	0.0	0.0	0.4	0.0	3.8	0.4
C₄₊ Compounds	0.0	0.0	0.0	4.5	0.0	0.0	4.5
H₂O	0.0	58.7	123.1	620.0	0.0	0.0	39.0
Hydrogen	0.0	16.2	2.0	37.6	0.0	0.0	37.7
Argon	0.0	46.6	46.6	47.7	1.1	0.0	47.7
Nitrogen	0.0	249.9	249.9	252.9	3.0	0.0	252.9
Oxygen	0.0	0.0	0.0	0.0	839.6	0.0	0.0
CO	0.0	0.0	0.0	93.6	0.0	0.0	93.6
CO₂	0.0	0.0	19.2	493.5	0.0	0.0	493.9

2017	2016	2015	2014	2013	2012	2011	2010	2009	2008	Stream #
97.7	3181.9	460.1	458.5	457.9	5.1	3691.5	27.5	3238.1	581.1	Total (1000 lb/hr)
0.0	2303.4	395.0	394.7	394.7	0.0	2303.4	0.0	1908.7	0.0	Methane
0.0	269.0	0.0	0.0	0.0	0.0	269.0	0.0	269.0	0.0	Ethylene
0.0	138.7	35.9	35.9	35.9	0.0	138.7	0.0	102.8	0.0	Ethane
0.0	3.7	0.0	0.0	0.0	0.0	3.7	0.0	3.7	0.0	Acetylene
0.0	10.4	0.0	0.0	0.0	0.0	10.4	0.0	10.4	0.0	Propene
0.0	5.5	5.1	5.1	5.1	0.0	5.5	0.0	0.4	0.0	Propane
0.0	7.3	2.8	2.8	2.8	0.0	7.3	0.0	4.5	0.0	C ₄₊ Compounds
1.3	7.9	1.2	0.0	0.0	5.1	7.9	27.5	12.9	581.0	H ₂ O
0.0	38.2	0.5	0.5	0.0	0.0	38.2	0.0	37.7	0.0	Hydrogen
0.0	47.7	0.0	0.0	0.0	0.0	47.7	0.0	47.7	0.0	Argon
0.0	256.6	3.7	3.7	3.7	0.0	256.6	0.0	252.9	0.0	Nitrogen
0.0	0.0	0.0	0.0	0.0	0.0	0.0	0.0	0.0	0.0	Oxygen
0.0	93.6	0.0	0.0	0.0	0.0	93.6	0.0	93.6	0.0	CO
96.4	0.0	15.7	15.7	15.7	0.0	509.6	0.0	493.9	0.0	CO ₂

2027	2026	2025	2024	2023	2022	2021	2020	2019	2018	Stream #
23.5	432.2	647.7	2094.2	6.1	34.5	2694.7	45.3	3174.1	424.4	Total (1000 lb/hr)
0.0	0.0	488.9	1814.5	0.0	26.1	2268.5	0.0	2303.4	0.0	Methane
0.0	266.6	0.2	2.2	0.0	0.0	2.4	0.0	269.0	0.0	Ethylene
0.2	138.7	0.0	0.0	0.0	0.0	0.0	0.0	138.7	0.0	Ethane
0.0	3.7	0.0	0.0	0.0	0.0	0.0	0.0	3.7	0.0	Acetylene
10.4	10.4	0.0	0.0	0.0	0.0	0.0	0.0	10.4	0.0	Propene
5.5	5.5	0.0	0.0	0.0	0.0	0.0	0.0	5.5	0.0	Propane
7.3	7.3	0.0	0.0	0.0	0.0	0.0	0.0	7.3	0.0	C ₄₊ Compounds
0.0	0.0	0.0	0.0	6.1	0.0	0.0	0.0	0.0	12.1	H ₂ O
0.0	0.0	18.1	20.2	0.0	1.0	36.0	1.1	38.2	0.0	Hydrogen
0.0	0.0	14.9	32.8	0.0	0.8	46.6	6.7	47.7	0.0	Argon
0.0	0.0	92.8	163.8	0.0	4.9	249.9	0.0	256.6	0.0	Nitrogen
0.0	0.0	0.0	0.0	0.0	0.0	0.0	2.4	0.0	0.0	Oxygen
0.0	0.0	32.9	60.8	0.0	1.8	91.3	0.0	93.6	0.0	CO
0.0	0.0	0.0	0.0	0.0	0.0	0.0	35.2	0.0	412.4	CO ₂

2037	2036	2035	2034	2033	2032	2031	2030	2029	2028	Stream #
1508.6	7.2	16.2	143.2	266.0	409.2	33.6	0.5	0.4	408.8	Total (1000 lb/hr)
0.0	0.0	0.0	0.0	0.0	0.0	26.1	0.0	0.0	0.0	Methane
0.0	0.0	0.0	2.7	265.9	268.6	0.0	0.0	0.0	266.6	Ethylene
0.0	0.0	0.2	140.5	0.0	140.6	0.0	0.0	0.0	138.5	Ethane
0.0	0.0	0.0	0.0	0.1	0.0	0.0	0.0	0.0	3.7	Acetylene
1508.6	0.0	10.4	0.0	0.0	0.0	0.0	0.0	0.0	0.0	Propene
0.0	0.0	5.5	0.0	0.0	0.0	0.0	0.0	0.0	0.0	Propane
0.0	7.2	0.1	0.0	0.0	0.0	0.0	0.0	0.0	0.0	C ₄₊ Compounds
0.0	0.0	0.0	0.0	0.0	0.0	0.0	0.0	0.0	0.0	H ₂ O
0.0	0.0	0.0	0.0	0.0	0.0	0.0	0.5	0.4	0.0	Hydrogen
0.0	0.0	0.0	0.0	0.0	0.0	0.8	0.0	0.0	0.0	Argon
0.0	0.0	0.0	0.0	0.0	0.0	4.9	0.0	0.0	0.0	Nitrogen
0.0	0.0	0.0	0.0	0.0	0.0	0.0	0.0	0.0	0.0	Oxygen
0.0	0.0	0.0	0.0	0.0	0.0	1.8	0.0	0.0	0.0	CO
0.0	0.0	0.0	0.0	0.0	0.0	0.0	0.0	0.0	0.0	CO ₂

2046	2045	2044	2043	2042	2041	2040	2039	2038	Stream #
1152.1	300.4	851.7	524.8	326.9	2066.0	130.1	1935.9	427.3	Total (1000 lb/hr)
0.0	0.0	0.0	0.0	0.0	0.0	0.0	0.0	0.0	Methane
1152.1	300.4	851.7	524.8	326.9	0.0	0.0	0.0	0.0	Ethylene
0.0	0.0	0.0	0.0	0.0	0.0	0.0	0.0	0.0	Ethane
0.0	0.0	0.0	0.0	0.0	0.0	0.0	0.0	0.0	Acetylene
0.0	0.0	0.0	0.0	0.0	2066.0	130.1	1935.9	427.3	Propene
0.0	0.0	0.0	0.0	0.0	0.0	0.0	0.0	0.0	Propane
0.0	0.0	0.0	0.0	0.0	0.0	0.0	0.0	0.0	C ₄₊ Compounds
0.0	0.0	0.0	0.0	0.0	0.0	0.0	0.0	0.0	H ₂ O
0.0	0.0	0.0	0.0	0.0	0.0	0.0	0.0	0.0	Hydrogen
0.0	0.0	0.0	0.0	0.0	0.0	0.0	0.0	0.0	Argon
0.0	0.0	0.0	0.0	0.0	0.0	0.0	0.0	0.0	Nitrogen
0.0	0.0	0.0	0.0	0.0	0.0	0.0	0.0	0.0	Oxygen
0.0	0.0	0.0	0.0	0.0	0.0	0.0	0.0	0.0	CO
0.0	0.0	0.0	0.0	0.0	0.0	0.0	0.0	0.0	CO ₂

[00337] **Table 2** shows the temperatures for select streams of the example process. Stream numbers correspond to those of **Examples 4-7** and **FIGs. 26-31**.

Table 2: Stream temperatures

Stream #	Temperature (°F)	Stream #	Temperature (°F)
2001	100	2024	-30
2002	100	2025	15
2003	1000	2026	-33
2004	1528	2027	145
2005	95	2028	-17
2006	1022	2029	100
2007	100	2030	100
2008	100	2031	100
2009	100	2032	-9
2010	100	2033	100
2011	100	2034	-33
2012	100	2035	126
2013	100	2036	100
2014	500	2937	-52
2015	501	2938	-7
2016	102	2039	139
2017	100	2040	59
2018	100	2041	192
2019	55	2042	-154
2020	43	2043	-120
2021	43	2044	-22
2022	40	2045	-94
2023	55	2046	83

EXAMPLE 9: Equipment, materials of construction and utilities

[00338] The material of construction for the different process units shown in **FIGs. 26-31** is tabulated in the major equipment list (**Tables 3-8**). Carbon steel material can be used for construction of at least some or most of the process equipment as the reaction medium is not

corrosive. The distillation column shell and, heat exchanger shells can be constructed out of carbon steel (C.S.) or stainless steel (SS). Distillation column internals are made of stainless steel whereas the reactor shells are constructed of carbon steel. The Transfer Line Exchangers used for high pressure steam are made of Mo-Alloy steel.

[00339] The process gas compression and treatment section has two pumps and two spares operating at 516 BHP, the product separation and recovery section has four pumps and four spares operating at 1714 BHP, the refrigeration section has one pump and one spare operating at 128 BHP.

Table 3: Reactors and materials of construction

Name	Number	Size	Material of Construction	Remarks
OCM reactor Stage-I	111- R101	19 ft. dia	shell: C.S.	2 sieve trays, 24 inch spacing
		15 ft. T-T	trays: 304 SS	Reactor Bed: H= 8.3 ft., D=17 ft.; 12" refractory lining
OCM reactor Stage-II	111- R102	19 ft. dia	shell: C.S.	4 sieve trays, 24 inch spacing
		22 ft. T-T	trays: 304 SS	Reactor Bed: H= 8.3 ft., D=17 ft.; 12" refractory lining, Post Bed Cracking bed height=7ft
Methanation Stage-I	111- R103	18 ft. dia	shell: C.S.	2 sieve trays, 24 inch spacing
		20 ft. T-T	trays: 304 SS	Reactor bed: H=15 ft.
Methanation Stage-II	111- R104	18 ft. dia	shell: C.S.	2 sieve trays, 24 inch spacing
		20 ft. T-T	trays: 304 SS	Reactor bed: H=15 ft.
NG desulfurization	180- D802A	13 ft. dia	shell: C.S.	4 sieve trays, 24 inch spacing
		38 ft. T-T	trays: 304 SS	Top reaction bed: H=6.4 ft. Bottom zinc oxide filter bed: H=26 ft.
Acetylene hydrogenation	171- R711	12 ft. dia	shell: C.S.	2 sieve trays, 24 inch spacing

Name	Number	Size	Material of Construction	Remarks
reactor		20 ft. T-T	trays: 304 SS	Reactor bed: H=15 ft.

Table 4: Columns and materials of construction

Name	Number	Size	Material of Construction	Remarks
Process Gas Quench tower-I	111- D109	32 ft. dia	shell: C.S.	10 sieve trays, 12 inch spacing
		40 ft.	trays: 304 SS	
Process Gas Quench tower-II	120- D202	25 ft. dia	shell: C.S.	10 sieve trays, 12 inch spacing
		35 ft.	trays: 304 SS	
Process Gas Quench tower-III	120- D203	20 ft. dia	shell: C.S.	10 sieve trays, 12 inch spacing
		30 ft.	trays: 304 SS	
Demethanizer	150- T501	18 ft. dia	shell: S.S.	60 valve trays, 24 inch spacing
		155 ft.	trays: 304 SS	Top section: D=18 ft., H=35 ft.,15 trays; Bottom section: D=12 ft., H=120 ft.,45 trays
Deethanizer	170- T701	11 ft. dia	shell: S.S.	40 sieve trays, 12 inch spacing
		60 ft.	trays: 304 SS	
C ₂ splitter	160- T601	20 ft. dia	shell: C.S.	110 sieve trays, 12 inch spacing
		140 ft.	trays: 304 SS	
Depropanizer	190- T801	3.5 ft. dia	shell: C.S.	20 valve trays, 24 inch spacing
		50 ft.	trays: 304 SS	

Table 5: Compressors and materials of construction

Name	Number	Size	Remarks
Process Gas compressor Stage-I	120- C202/C203	63,500 bhp (EACH)	STEAM turbine
Process Gas compressor Stage-II	120-C204	68,930 bhp	STEAM turbine
PSA feed compressor	172-C721	4,700 bhp	electric motor
Ethylene Product Compressor	160-C601	29,390 bhp	3-stage compressor; steam turbine
Propylene Compressor	175-C751	58,500 bhp	3 stage compressor; steam turbine
Ethylene Compressor	176-C761	30,360 bhp	Includes 3-stage compressor with intercoolers; steam turbine

[00340] All of the compressors in Table 5 are constructed from carbon steel.

Table 6: Heat exchangers and materials of construction

Name	Number	Size	Material of Construction	Comments
Methane recycle heater-I	111-E101	47,300 sq. ft.	shell: C.S.	
		252.3 MMBtu/hr	tubes: C.S.	
Methanation product heater	111-E102	109,720 sq. ft. (EACH)	shell: C.S.	
		1,083 MMBtu/hr	tubes: C.S.	
OCM-I product cooler-I	111- E103A/B	16,200 sq. ft. (EACH)	shell: Mo alloy steel	Transfer Line Exchanger; generates 1500 psia steam
		1,330 MMBtu/hr	tubes: Mo alloy steel	
OCM-I product cooler-II	111- E103C	24,500 sq. ft.	shell: C.S.	Superheats 1500 psia steam to 890 °F
		443.5 MMBtu/hr	tubes: C.S.	

Name	Number	Size	Material of Construction	Comments
OCM-II product cooler-I	111-E104A/B	21,900 sq. ft. (EACH)	shell: Mo alloy steel	Transfer Line Exchanger; generates 1500 psia steam
		995 MMBtu/hr	tubes: Mo alloy steel	
OCM-II product cooler-II	111-E104C	15,990 sq. ft.	shell: C.S.	Superheats 1500 psia steam to 890 °F
		324.4 MMBtu/hr	tubes: C.S.	
Ethane recycle heater	111-E105	20,700 sq. ft.	shell: C.S.	
		163.6 MMBtu/hr	tubes: C.S.	
OCM-II product cooler-III	111-E106	37,325 sq. ft. (EACH)	shell: C.S.	
		531.8 MMBtu/hr	tubes: C.S.	
OCM-II product cooler-IV	111-E107	42,450 sq. ft.	shell: C.S.	
		271 MMBtu/hr	tubes: C.S.	
Methane recycle heater-II	111-E108	42,480 sq. ft. (EACH)	shell: C.S.	
		297.9 MMBtu/hr	tubes: C.S.	
Quench tower-I cooler	111-E109	40,700 sq. ft. (EACH)	shell: C.S.	Plate and frame exchanger
		609.9 MMBtu/hr	tubes: 304 SS	
NG feed heater-I	HRSG Coil	35,100 sq. ft.	shell: C.S.	
		132.4 MMBtu/hr	tubes: C.S.	
Quench tower-II	120-	52,750 sq. ft.	shell: C.S.	Plate and frame

Name	Number	Size	Material of Construction	Comments
cooler	D202			exchanger
		292.3 MMBtu/hr	tubes: 304 SS	
Quench tower-III cooler	120-D203	57,530 sq. ft.	shell: C.S.	Plate and frame exchanger
		267.7 MMBtu/hr	tubes: 304 SS	
CO ₂ lean gas cooler-I	145-E301	18,250 sq. ft.	shell: C.S.	
		81.67 MMBtu/hr	tubes: C.S.	
CO ₂ lean gas cooler-II	145-E302	8,500 sq. ft.	shell: C.S.	
		9.27 MMBtu/hr	tubes: C.S.	
Demethanizer feed cooler	150-E501		shell: Low temp C.S.	Custom cold box, Weight: 44,300 lbs; W: 4.5 ft., H: 5.8 ft. and L: 22 ft.
			tubes: low temp C.S.	
Acetylene reactor feed heater	171-E711	30,970 sq. ft.	shell: C.S.	
		21.44 MMBtu/hr	tubes: C.S.	
Acetylene reactor prod cooler	171-E712	4,230 sq. ft.	shell: C.S.	
		9.29 MMBtu/hr	tubes: 304 SS	
Deetha OVHD condenser	170-E701	22,820 sq. ft.	shell: C.S.	
		30.7 MMBtu/hr	tubes: 304 SS	

Name	Number	Size	Material of Construction	Comments
Deethanizer reboiler	170-E702	7,900 sq. ft.	shell: C.S.	
		73.6 MMBtu/hr	tubes: C.S.	
C ₂ splitter cold box	160-E601/603		shell: C.S. tubes: C.S.	Includes C ₂ splitter condenser and reboiler; Weight: 57,465 lbs ; W: 4.5 ft., H: 6 ft. and l: 27.6 ft.
Depropanizer OVHD condenser	190-E801	3,350 sq. ft.	shell: C.S.	
		3.85 MMBtu/hr	tubes: 304 SS	
Depropanizer reboiler	190-E802	2,280 sq. ft.	shell: C.S.	
		5.97 MMBtu/hr	tubes: C.S.	
C ₄₊ product cooler	190-E803	350 sq. ft.	shell: C.S.	
		0.7 MMBtu/hr	tubes: C.S.	
Propylene cooler	175-E751	48,275 sq. ft. (EACH)	shell: C.S.	
		363.6 MMBtu/hr	tubes: 304 SS	
Ethylene cooler	178-E781	49,030 sq. ft.	shell: C.S.	
		240.9 MMBtu/hr	tubes: 304 SS	

Table 7: Tanks and materials of construction (stainless steel shell for demethanizer and deethanizer)

Name	Number	Size
50% Caustic Storage	900-T901	95,000 gal
Spent Caustic Holdup	900-T902	115,000 gal
Amine Dump Tank	900-T903	150,000 gal
Amine Make-up storage	900-T904	4,000 gal
C ₄₊ product storage	900-T905	35,000 gal

Table 8: Pressure vessels and materials of construction (stainless steel shell for demethanizer and deethanizer)

Name	Number	Size
NG feed KO drum	180-D801	4,030 gal
Process Gas KO drum	145-D301	33,089 gal
Deethanizer reflux drum	170-D701	11,037 gal
Depropanizer reflux drum	190-D801	476 gal
Propylene collection drum	175-D754	39,657 gal
Propylene Flash Drum-I	175-D751	47,000 gal
Propylene Flash Drum-II	175-D752	19,829 gal
Propylene Flash drum-III	175-D753	91,800 gal
Ethylene collection drum	176-D764	23,460 gal
Ethylene Flash drum-I	176-D761	20,305 gal
Ethylene Flash drum-II	176-D762	15,640 gal
Ethylene Flash drum-III	176-D763	28,865 gal

[00341] In addition, the process has: a natural gas heater (F-201) **2673** sized 35 MMBTU/HR made of carbon steel; three process gas driers (M-201 A-C) **2669** each having a capacity of 34,300 gallons made of carbon steel and having molecular sieve beds including all peripheral equipment and one spare column; a treated natural gas expander (S-201) **2674** of 4200 HP and made of carbon steel; a CO₂ removal unit (G-201) **2668** made of carbon steel and sized to 11.5 MMSCFD CO₂ including an amine scrubber, regeneration, caustic scrubber and peripheral units; a recycle split vapor (RSV) unit (G-301) **2680** made of carbon steel and including a cold box (Width: 4 ft., Height: 5.8 ft. and Length: 14.2 ft.), a compressor, two

turboexpanders, and two knockout drums; and a H2 pressure swing adsorption unit (G-302) 2686 made of carbon steel and having a size of 4.36 MMSCFD.

[00342] The utilities consumed by the process shown in FIGs. 26-31 are tabulated in Tables 9-10). Table 9 shows the average consumption of the utilities and Table 10 shows peak demands imposed upon the utilities. The utilities are scaled to be able to satisfy both average demands and peak demands.

Table 9: Average utility consumption

	Units	Battery Limits Total	OCM Reaction System	Compression & Treatment System	Separation and Recovery System	Refrigeration Section
Cooling Water	gpm	244,172	61,088	145,346	1,317	36,421
Natural Gas	MM Btu/hr	47	N/A	47	N/A	N/A
Steam, 150 psig	M lb/hr	1,030	N/A	1,030	N/A	N/A
Steam, 860 psig	M lb/hr	1,726	N/A	N/A	625	1,101
Steam, 1500 psig	M lb/hr	2,963	N/A	2,920	43	--
Steam, 150 psig	M lb/hr	-1,225	N/A	N/A	-625	-600
Steam, 860 psig	M lb/hr	-1,977	N/A	-1,977	N/A	N/A
Steam, 1500 psig	M lb/hr	-2,963	-2,963	N/A	N/A	N/A

Table 10: Peak utility consumption

	Units	Battery Limits Total	OCM Reaction System	Compression & Treatment System	Separation and Recovery System	Refrigeration Section
Cooling Water	gpm	293,007	73,306	174,416	1,580	43,705
Electricity	kW	-6,668	N/A	4,428	-11,202	106
Steam, 150 psig	M lb/hr	1,236	--	1,236	N/A	N/A
Steam, 860 psig	M lb/hr	2,071	--	N/A	750	1,321
Steam, 1500 psig	M lb/hr	3,556	--	3,504	52	N/A

[00343] It should be understood from the foregoing that, while particular implementations have been illustrated and described, various modifications can be made thereto and are contemplated herein. It is also not intended that the invention be limited by the specific examples provided within the specification. While the invention has been described with reference to the aforementioned specification, the descriptions and illustrations of the preferable embodiments herein are not meant to be construed in a limiting sense. Furthermore, it shall be understood that all aspects of the invention are not limited to the specific depictions, configurations or relative proportions set forth herein which depend upon a variety of conditions and variables. Various modifications in form and detail of the embodiments of the invention will be apparent to a person skilled in the art. It is therefore contemplated that the invention shall also cover any such modifications, variations and equivalents. It is intended that the following claims define the scope of the invention and that methods and structures within the scope of these claims and their equivalents be covered thereby.

CLAIMS

WHAT IS CLAIMED IS:

1. An oxidative coupling of methane (OCM) system for small scale or world scale production of olefins, comprising:
 - (a) an OCM subsystem that (i) takes as input a feed stream comprising methane (CH₄) and a feed stream comprising an oxidizing agent, and (ii) generates from said methane and said oxidizing agent a product stream comprising C₂₊ compounds and non-C₂₊ impurities; and
 - (b) at least one separations subsystem downstream of, and fluidically coupled to, said OCM subsystem, wherein said separations subsystem comprises a first heat exchanger, a de-methanizer unit downstream of said first heat exchanger, and a second heat exchanger downstream of said de-methanizer unit, wherein
 - (1) said first heat exchanger cools said product stream,
 - (2) said de-methanizer unit accepts said product stream from said first heat exchanger and generates an overhead stream comprising methane and at least a portion of said non-C₂₊ impurities, and a bottoms stream comprising at least a portion of said C₂₊ compounds, and
 - (3) at least a portion of said overhead stream is cooled in said second heat exchanger and is subsequently directed to said first heat exchanger to cool said product stream.
2. The system of Claim 1, wherein said overhead stream is split into at least two streams, and at least one of said two streams is pressurized prior to introduction to said second heat exchanger.
3. The system of Claim 1, further comprising a hydrogenation unit downstream of said de-methanizer, wherein said hydrogenation unit accepts a stream comprising said C₂₊ compounds and hydrogenates alkynes in said C₂₊ compounds to alkanes and/or alkenes.
4. The system of Claim 1, further comprising a de-ethanizer unit downstream of said hydrogenation unit, wherein said de-ethanizer unit accepts said stream and separates ethane from ethylene.
5. The system of Claim 1, further comprising a methanation subsystem upstream of said OCM subsystem, wherein said methanation subsystem reacts H₂ with CO and/or CO₂ to generate methane, which methane is directed to said OCM subsystem.

6. The system of Claim 1, further comprising a sulfur removal subsystem upstream of said OCM subsystem, wherein said sulfur removal subsystem accepts a feed stream comprising methane and decrease the concentration of sulfur in said feed stream.
7. The system of Claim 6, wherein said sulfur removal subsystem further comprises a heat recovery steam generator unit.
8. The system of Claim 1, further comprising an absorption system downstream of said OCM subsystem, wherein said absorption system decreases the concentration of CO₂ in said product stream.
9. The system of Claim 8, wherein said absorption system comprises an absorption unit and a scrubber downstream of said absorption unit.
10. The system of Claim 1, wherein said oxidizing agent is O₂.
11. The system of Claim 10, wherein said O₂ is provided by air.
12. The system of Claim 1, wherein said OCM subsystem comprises at least one OCM reactor.
13. The system of Claim 12, wherein said OCM subsystem comprises at least one post-bed cracking unit downstream of said at least one OCM reactor, which post-bed cracking unit is configured to convert at least a portion of alkanes in said product stream to alkenes.
14. The system of Claim 1, further comprising a non-OCM process upstream of said OCM subsystem.
15. The system of Claim 14, wherein said non-OCM process is a natural gas liquids process.
16. The system of Claim 1, wherein said non-C₂₊ impurities comprise one or more of nitrogen (N₂), oxygen (O₂), water (H₂O), argon (Ar), carbon monoxide (CO), carbon dioxide (CO₂) and CH₄.
17. An oxidative coupling of methane (OCM) system for small scale or world scale production of olefins, comprising:
 - (a) an OCM subsystem that (i) takes as input a feed stream comprising methane (CH₄) and a feed stream comprising an oxidizing agent, and (ii) generates from said methane and said oxidizing agent a product stream comprising C₂₊ compounds and non-C₂₊ impurities; and
 - (b) at least one methanation subsystem downstream of, and fluidically coupled to, said OCM subsystem, wherein said methanation subsystem reacts H₂ and CO and/or CO₂ included in said non-C₂₊ impurities to generate methane.
18. The system of Claim 17, wherein at least a portion of said methane generated in said methanation subsystem is recycled to said OCM subsystem.

19. The system of Claim 17, wherein said oxidizing agent is O₂.
20. The system of Claim 19, wherein said O₂ is provided by air.
21. The system of Claim 17, wherein said OCM subsystem comprises at least one OCM reactor.
22. The system of Claim 21, wherein said OCM subsystem comprises at least one post-bed cracking unit downstream of said at least one OCM reactor, which post-bed cracking unit is configured to convert at least a portion of alkanes in said product stream to alkenes.
23. The system of Claim 17, further comprising a non-OCM process upstream of said OCM subsystem.
24. The system of Claim 23, wherein said non-OCM process is a natural gas liquids process.
25. The system of Claim 17, wherein said non-C₂₊ impurities comprise one or more of nitrogen (N₂), oxygen (O₂), water (H₂O), argon (Ar), carbon monoxide (CO), carbon dioxide (CO₂) and CH₄.
26. The system of Claim 17, wherein said methanation subsystem comprises at least one methanation reactor.
27. A catalyst for hydrogenation of acetylene in an oxidative coupling of methane (OCM) process comprising at least one metal element, wherein the catalyst is capable of decreasing the concentration of acetylene to less than about 100 parts per million (ppm) in an OCM effluent.
28. The catalyst of Claim 27, wherein the catalyst is capable of decreasing the concentration of acetylene to less than about 10 ppm in the OCM effluent.
29. The catalyst of Claim 28, wherein the catalyst is capable of decreasing the concentration of acetylene to less than about 1 ppm in the OCM effluent.
30. The catalyst of Claim 27, wherein the at least one metal element is palladium.
31. The catalyst of Claim 27, wherein the at least one metal element is part of a metal oxide.
32. The catalyst of Claim 27, wherein the catalyst is capable of providing an OCM effluent that comprises at least about 0.5% carbon monoxide.
33. The catalyst of Claim 32, wherein the catalyst is capable of providing an OCM effluent that comprises at least about 1% carbon monoxide.
34. The catalyst of Claim 33, wherein the catalyst is capable of providing an OCM effluent that comprises at least about 3% carbon monoxide.
35. The catalyst of Claim 27, wherein the catalyst has a lifetime of at least about 1 year.
36. The catalyst of Claim 27, wherein the catalyst is capable of providing an OCM effluent that comprises at least about 0.1% acetylene.

37. The catalyst of Claim 36, wherein the catalyst is capable of providing an OCM effluent that comprises at least about 0.3% acetylene.
38. The catalyst of Claim 37, wherein the catalyst is capable of providing an OCM effluent that comprises at least about 0.5% acetylene.
39. The catalyst of Claim 27, wherein the at least one metal element comprises a plurality of metal elements.
40. A catalyst for converting carbon monoxide (CO) and/or carbon dioxide (CO₂) into methane (CH₄) in an oxidative coupling of methane (OCM) process, wherein the catalyst comprises at least one metal element for converting CO and/or CO₂ into CH₄ at a selectivity for the formation of methane that is at least about 10-fold greater than the selectivity of the catalyst for formation of coke in an OCM effluent.
41. The catalyst of Claim 40, wherein the catalyst has a selectivity for the formation of methane that is at least about 100-fold greater than the selectivity of the catalyst for formation of coke.
42. The catalyst of Claim 41, wherein the catalyst has a selectivity for the formation of methane that is at least about 1000-fold greater than the selectivity of the catalyst for formation of coke.
43. The catalyst of Claim 42, wherein the catalyst has a selectivity for the formation of methane that is at least about 10000-fold greater than the selectivity of the catalyst for formation of coke.
44. The catalyst of Claim 40, wherein the OCM effluent comprises at least about 3% olefin and/or acetylene compounds.
45. The catalyst of Claim 44, wherein the OCM effluent comprises at least about 5% olefin and/or acetylene compounds.
46. The catalyst of Claim 45, wherein the OCM effluent comprises at least about 10% olefin and/or acetylene compounds.
47. The catalyst of Claim 40, wherein the at least one metal element is nickel.
48. The catalyst of Claim 40, wherein the at least one metal element is part of a metal oxide.
49. A method for preventing coke formation on a methanation catalyst in an oxidative coupling of methane (OCM) process, the method comprising (a) providing an OCM effluent comprising carbon monoxide (CO) and/or carbon dioxide (CO₂) and (b) using a methanation catalyst to perform a methanation reaction with the OCM effluent, wherein (i) hydrogen and/or water is added to the OCM effluent prior to (b), (ii) olefins and/or acetylene in the OCM effluent

is hydrogenated prior to (b); and/or (iii) olefins and/or acetylene are separated and/or condensed from the OCM effluent prior to (b).

50. The method of Claim 49, wherein (iii) is performed using absorption or adsorption.

51. The method of Claim 49, wherein the methanation reaction forms at least about 1000-fold more methane than coke.

52. The method of Claim 51, wherein the methanation reaction forms at least about 10000-fold more methane than coke.

53. The method of Claim 52, wherein the methanation reaction forms at least about 100000-fold more methane than coke.

54. The method of Claim 49, further comprising any two of (i), (ii) and (iii).

55. The method of Claim 54, further comprising all of (i), (ii) and (iii).

56. An oxidative coupling of methane (OCM) system for production of olefins and power, comprising:

(a) an OCM subsystem that (i) takes as input a feed stream comprising methane (CH_4) and a feed stream comprising an oxidizing agent, and (ii) generates from said methane and said oxidizing agent a product stream comprising C_{2+} compounds and heat; and

(b) a power subsystem fluidically and/or thermally coupled to said OCM subsystem that converts said heat into electrical power.

57. The system of Claim 56, wherein said oxidizing agent is O_2 .

58. The system of Claim 57, wherein said O_2 is provided by air.

59. The system of Claim 56, wherein said OCM subsystem comprises at least one OCM reactor.

60. The system of Claim 59, wherein said OCM subsystem comprises at least one post-bed cracking unit within said at least one OCM reactor or downstream of said at least one OCM reactor, which post-bed cracking unit is configured to convert at least a portion of alkanes in said product stream to alkenes.

61. The system of Claim 56, wherein said power subsystem is a gas turbine combined cycle (GTCC).

62. The system of Claim 56, further comprising a steam generator for generating steam from said heat, which steam is converted to electrical power in the power subsystem.

63. The system of Claim 56, wherein said power subsystem comprises a gas turbine and unreacted methane from said OCM subsystem is converted to electrical power using said gas turbine.

64. The system of Claim 56, wherein a ratio of production of C_{2+} alkenes and production of power can be varied by adjusting a composition of said feed stream.
65. The system of Claim 56, wherein a ratio of production of C_{2+} alkenes and production of power can be varied by adjusting an amount of C_{2+} alkanes fed into a post-bed cracking section of said OCM subsystem.
66. A method for producing at least one C_{2+} alkene and power, comprising:
- (a) directing methane and an oxidizing agent into a reactor comprising a catalyst unit, wherein said catalyst unit comprises an oxidative coupling of methane (OCM) catalyst that facilitates an OCM reaction that produces C_{2+} alkene;
 - (b) reacting said methane and oxidizing agent with the aid of said OCM catalyst to generate at least one OCM product comprising at least one C_{2+} compound and heat; and
 - (c) generating electrical power from said heat.
67. The method of Claim 66, wherein said heat is converted to steam and said steam is converted to power in a steam turbine.
68. The method of Claim 66, wherein un-reacted methane from said reactor is converted to electrical power in a gas turbine.
69. The method of Claim 67, wherein said reactor comprises a cracking unit downstream of said catalyst unit, wherein said cracking unit generates C_{2+} alkene from C_{2+} alkane, and wherein the method further comprises;
- (d) providing at least one hydrocarbon-containing stream that is directed through said cracking unit, which hydrocarbon-containing stream comprises at least one C_{2+} alkane; and
 - (e) in said cracking unit, cracking said at least one C_{2+} alkane to provide said at least one C_{2+} alkene in a product stream that is directed out of said reactor.
70. The method of Claim 69, wherein said hydrocarbon-containing stream comprises at least one OCM product.
71. The method of Claim 69, wherein said C_{2+} alkene produced from said at least one hydrocarbon-containing stream in said cracking unit is in addition to said C_{2+} alkene produced from said methane and said oxidizing agent in said reactor.
72. The method of Claim 69, wherein the amount of steam produced is varied or the amount of at least one hydrocarbon-containing stream that is directed through said cracking unit is varied to alter the amount of electrical power produced and the amount of C_{2+} alkene produced.
73. The method of Claim 66, wherein said OCM catalyst is a nanowire catalyst.

74. The method of Claim 66, wherein said oxidizing agent is O₂.
75. The method of Claim 66, wherein said at least one C₂₊ alkane comprises a plurality of C₂₊ alkanes.
76. The method of Claim 69, wherein said cracking unit generates C₂₊ alkene from C₂₊ alkane with the aid of said heat generated in said OCM reaction.
77. The method of Claim 66, wherein said reactor is adiabatic.
78. A method for producing hydrocarbon compounds including two or more carbon atoms (C₂₊ compounds), the method comprising:
- (a) performing an oxidative coupling of methane (OCM) reaction in an OCM reactor to produce an OCM effluent comprising carbon dioxide (CO₂), hydrogen (H₂), one or more C₂₊ compounds, and methane (CH₄);
 - (b) separating the OCM effluent into (i) a first stream comprising at least some of the one or more C₂₊ compounds and (ii) a second stream comprising carbon monoxide (CO), CO₂, H₂, and CH₄;
 - (c) methanating the second stream to produce a first OCM reactor feed comprising CH₄ formed from the H₂ and CO and/or CO₂ in the second stream;
 - (d) methanating a third stream comprising CH₄ and H₂ to produce a second OCM reactor feed comprising CH₄, which third stream is from an ethylene cracker; and
 - (e) directing the first and second OCM reactor feeds to the OCM reactor.
79. The method of Claim 78, wherein the second stream and the third stream are methanated in a single methanation reactor.
80. The method of Claim 78, further comprising providing at least a portion of the first stream to the ethylene cracker.
81. The method of Claim 80, wherein the at least the portion of the first stream is provided to a gas compressor or a fractionation unit of the ethylene cracker.
82. The method of Claim 78, wherein the third stream is the overhead stream of a demethanizer unit of the ethylene cracker.
83. The method of Claim 78, wherein the separating in (b) is performed at least in part in a pressure swing adsorption (PSA) unit.
84. The method of Claim 78, wherein the separating in (b) is performed at least in part with a CO₂ removal system or a process gas dryer.
85. The method of Claim 78, wherein the OCM effluent is compressed prior to (b).
86. The method of Claim 78, further comprising feeding oxygen (O₂) as an oxidizing agent to the OCM reactor, which O₂ takes part in the OCM reaction.

87. The method of Claim 78, wherein the OCM effluent comprises carbon monoxide (CO) that is converted into CH₄ in (c).
88. The method of Claim 78, wherein the OCM reaction further reacts CH₄ from natural gas to achieve additional ethylene production.
89. The method of Claim 78, wherein the third stream further comprises CH₄.
90. An oxidative coupling of methane (OCM) system for production of hydrocarbon compounds including two or more carbon atoms (C₂₊ compounds), comprising:
- (a) an OCM subsystem that (i) takes as input a first feed stream comprising methane (CH₄) and a second feed stream comprising an oxidizing agent, and (ii) generates a product stream comprising C₂₊ compounds from the CH₄ and the oxidizing agent;
 - (b) a separation subsystem fluidically coupled to the OCM subsystem that separates the product stream into (i) a first stream comprising C₂₊ compounds and (ii) a second stream comprising hydrogen (H₂) and carbon dioxide (CO₂) and/or carbon monoxide (CO);
 - (c) a methanation subsystem fluidically coupled to the second stream and to the OCM subsystem, wherein the methanation subsystem converts H₂ and CO₂ and/or CO into CH₄; and
 - (d) an ethylene cracker subsystem fluidically coupled to the methanation subsystem that provides CH₄, H₂, CO₂, and/or CO to the methanation subsystem.
91. The system of Claim 90, wherein the methanation subsystem provides CH₄ to the OCM subsystem.
92. The system of Claim 90, wherein at least some of the additional H₂ is derived from a demethanizer of the ethylene cracker subsystem.
93. The system of Claim 90, wherein the first stream is fluidically coupled to the ethylene cracker subsystem.
94. The system of Claim 93, wherein the first stream is fractionated in the ethylene cracker subsystem.
95. The system of Claim 90, wherein the separation subsystem comprises a pressure swing adsorption (PSA) unit.
96. The system of Claim 90, wherein the OCM subsystem reacts CH₄ from natural gas with the oxidizing agent in an OCM reaction.
97. The system of Claim 90, wherein the oxidizing agent comprises O₂.
98. The system of Claim 98, wherein the O₂ is generated from air.

99. The system of Claim 90, wherein the OCM subsystem comprises at least one OCM reactor.
100. The system of Claim 99, wherein the OCM subsystem comprises at least one post-bed cracking unit within the at least one OCM reactor or downstream of the at least one OCM reactor, which post-bed cracking unit is configured to convert at least a portion of alkanes in the product stream to alkenes.
101. The system of Claim 99, wherein the reactor is adiabatic.
102. A method for producing hydrocarbon compounds including two or more carbon atoms (C_{2+} compounds), the method comprising:
- (a) performing an oxidative coupling of methane (OCM) reaction in an OCM reactor to produce an OCM effluent stream comprising carbon dioxide (CO_2), hydrogen (H_2), one or more C_{2+} compounds, and methane (CH_4);
 - (b) separating the OCM effluent stream into a first stream comprising at least some of the one or more C_{2+} compounds and a second stream comprising carbon monoxide (CO), CO_2 , H_2 , and CH_4 ;
 - (c) methanating the second stream to produce a first methanated stream comprising CH_4 formed from the H_2 and CO and/or CO_2 in the second stream;
 - (d) removing at least a portion of the first methanated stream; and
 - (e) directing the portion of the first methanated stream into a natural gas pipeline.
103. The method of claim 102, wherein (e) comprises directing the portion of the first methanated stream into the natural gas pipeline in exchange for an item of value.
104. A method for producing hydrocarbon compounds including two or more carbon atoms (C_{2+} compounds), the method comprising:
- (a) performing a natural gas liquids (NGL) extraction in an NGL extraction unit to produce an NGL stream comprising ethane, propane, and/or butane and a methane stream comprising methane;
 - (b) directing the methane stream to an oxidative coupling of methane (OCM) reactor; and
 - (c) performing an OCM reaction in the OCM reactor using the methane stream to produce an OCM effluent comprising carbon dioxide (CO_2), hydrogen (H_2), one or more C_{2+} compounds, and methane (CH_4).
105. A method for producing hydrocarbon compounds including two or more carbon atoms (C_{2+} compounds), the method comprising:

(a) performing an oxidative coupling of methane (OCM) reaction in an OCM reactor to produce an OCM effluent stream comprising carbon dioxide (CO₂), hydrogen (H₂), one or more C₂₊ compounds, and methane (CH₄);

(b) separating the OCM effluent stream into a first stream comprising at least some of the one or more C₂₊ compounds and a second stream comprising carbon monoxide (CO), CO₂, H₂, and CH₄;

(c) directing the second stream to a Fischer-Tropsch (F-T) reactor;

(d) in the F-T reactor, performing an F-T reaction using the second stream to produce a first OCM reactor feed comprising CH₄ formed from the H₂ and CO in the second stream; and

(e) directing the first OCM reactor feeds to the OCM reactor.

106. A method for producing hydrocarbon compounds including two or more carbon atoms (C₂₊ compounds), the method comprising:

(a) performing an oxidative coupling of methane (OCM) reaction in an OCM reactor to produce an OCM effluent stream comprising carbon dioxide (CO₂), hydrogen (H₂), one or more C₂₊ compounds, and methane (CH₄);

(b) separating the OCM effluent stream into a first stream comprising at least some of the one or more C₂₊ compounds and a second stream comprising carbon monoxide (CO), CO₂, H₂, and CH₄; and

(c) directing the OCM effluent stream to a heat recovery steam generator (HRSG) system;

(d) with the HRSG system, transferring heat from the OCM effluent stream to a water stream to produce steam.

107. A method for producing hydrocarbon compounds including two or more carbon atoms (C₂₊ compounds), the method comprising:

(a) performing an oxidative coupling of methane (OCM) reaction in an OCM reactor to produce an OCM effluent stream comprising carbon dioxide (CO₂), hydrogen (H₂), one or more C₂₊ compounds, and methane (CH₄);

(b) separating the OCM effluent stream into a first stream comprising at least some of the one or more C₂₊ compounds and a second stream comprising carbon monoxide (CO), CO₂, H₂, and CH₄;

(c) directing the second stream and an air stream to a gas compressor, and burning at least a portion of the second stream and compressing the air stream to produce a compressed air stream;

(d) separating the compressed air stream in an air separation unit (ASU) into a third stream comprising O_2 and a fourth stream comprising N_2 ; and

(e) feeding the oxygen-rich stream to the OCM reactor.

108. A method for producing hydrocarbon compounds including two or more carbon atoms (C_{2+} compounds), the method comprising:

(a) performing an oxidative coupling of methane (OCM) reaction in an OCM reactor to produce an OCM effluent stream comprising carbon dioxide (CO_2), hydrogen (H_2), one or more C_{2+} compounds, and methane (CH_4);

(b) transferring heat from the OCM effluent stream in a first heat exchanger and a second heat exchanger downstream of the first heat exchanger with respect to a flow direction of the OCM effluent stream, thereby cooling the OCM effluent stream;

(c) demethanizing the OCM effluent stream in a demethanizer, thereby producing an overhead stream comprising carbon dioxide (CO_2), hydrogen (H_2), and methane (CH_4) and a bottom stream comprising one or more C_{2+} compounds;

(d) expanding the overhead stream, thereby cooling the overhead stream;

(e) transferring heat to the overhead stream in the second heat exchanger and the first heat exchanger downstream of the second heat exchanger with respect to a flow direction of the overhead stream, thereby heating the overhead stream; and

(f) feeding the overhead stream from the first heat exchanger into the OCM reactor.

109. A method for producing hydrocarbon compounds including two or more carbon atoms (C_{2+} compounds), the method comprising:

(a) performing an oxidative coupling of methane (OCM) reaction in an OCM reactor to produce an OCM effluent stream comprising carbon dioxide (CO_2), hydrogen (H_2), one or more C_{2+} compounds, and methane (CH_4);

(b) transferring heat from the OCM effluent stream in a first heat exchanger and subsequently expanding the OCM effluent stream, thereby cooling the OCM effluent stream;

(c) demethanizing the OCM effluent stream in a demethanizer, thereby producing an overhead stream comprising carbon dioxide (CO_2), hydrogen (H_2), and methane (CH_4) and a bottom stream comprising one or more C_{2+} compounds;

(d) transferring heat to a first portion of the overhead stream in a second heat exchanger and the first heat exchanger downstream of the second heat exchanger with respect to a flow direction of the first portion of the overhead stream, thereby heating the first portion of the overhead stream;

(e) compressing a second portion of the overhead stream and, in a phase separation unit, separating the second portion of the overhead stream into a liquid stream and a vapor stream; and

(f) directing the liquid stream through the second heat exchanger and into the demethanizer.

110. The method of claim 109, further comprising expanding the vapor stream to cool the vapor stream.

111. The method of claim 109, further comprising transferring heat to the vapor stream in the second heat exchanger and the first heat exchanger.

112. A method for producing hydrocarbon compounds including two or more carbon atoms (C_{2+} compounds), the method comprising:

(a) performing an oxidative coupling of methane (OCM) reaction in an OCM reactor to produce an OCM effluent stream comprising carbon dioxide (CO_2), hydrogen (H_2), one or more C_{2+} compounds, and methane (CH_4);

(b) transferring heat from the OCM effluent stream in a first heat exchanger and subsequently expanding the OCM effluent stream, thereby cooling the OCM effluent stream;

(c) demethanizing the OCM effluent stream in a demethanizer, thereby producing an overhead stream comprising carbon dioxide (CO_2), hydrogen (H_2), and methane (CH_4) and a bottom stream comprising one or more C_{2+} compounds;

(d) compressing a first portion of the overhead stream, thereby heating the first portion of the overhead stream, and subsequently in a second heat exchanger transferring heat from the first portion of the overhead stream, thereby cooling the first portion of the overhead stream;

(e) in a phase separation unit, separating the first portion of the overhead stream into a liquid stream and a vapor stream; and

(f) transferring heat from the liquid stream in a third heat exchanger and subsequently directing the liquid stream into the demethanizer.

113. The method of claim 112, further comprising:

expanding the vapor stream, thereby cooling the vapor stream; and

transferring heat to the vapor stream in the third heat exchanger, the second heat exchanger, and/or the first heat exchanger, thereby heating the vapor stream.

114. The method of claim 112, further comprising:

expanding a second portion of the overhead stream, thereby cooling the second portion of the overhead stream; and

transferring heat to the second portion of the overhead stream in the third heat exchanger, the second heat exchanger, and/or the first heat exchanger, thereby heating the second portion of the overhead stream.

115. A method for producing hydrocarbon compounds including two or more carbon atoms (C_{2+} compounds), the method comprising:

(a) performing an oxidative coupling of methane (OCM) reaction in an OCM reactor to produce an OCM effluent stream comprising carbon dioxide (CO_2), hydrogen (H_2), one or more C_{2+} compounds, and methane (CH_4);

(b) transferring heat from the OCM effluent stream in a first heat exchanger, thereby cooling the OCM effluent stream;

(c) demethanizing the OCM effluent stream in a demethanizer, thereby producing an overhead stream comprising carbon dioxide (CO_2), hydrogen (H_2), and methane (CH_4) and a bottom stream comprising one or more C_{2+} compounds;

(d) compressing a first portion of the overhead stream, thereby heating the first portion of the overhead stream, and subsequently transferring heat from the first portion of the overhead stream in a second heat exchanger, thereby cooling the first portion of the overhead stream;

(e) in a first phase separation unit, separating the first portion of the overhead stream into a first liquid stream and a first vapor stream;

(f) expanding the vapor stream, thereby cooling the first vapor stream and subsequently transferring heat to the first vapor stream in the second heat exchanger and/or the first heat exchanger, thereby heating the first vapor stream; and

(g) sub-cooling and flashing the first liquid stream to produce a two-phase stream and, in a second phase separation unit, separating the two-phase stream into a second liquid stream and a second vapor stream, and directing the second liquid stream to the demethanizer.

116. A method for producing hydrocarbon compounds with two or more carbon atoms (C_{2+} compounds), the method comprising:

(a) performing an oxidative coupling of methane (OCM) reaction in an OCM system comprising two or more OCM reactor stages to produce an OCM effluent stream comprising carbon dioxide (CO_2), hydrogen (H_2), one or more C_{2+} compounds, and methane (CH_4);

(b) separating the OCM effluent into a first stream comprising at least some of the one or more C_{2+} compounds and a second stream comprising carbon monoxide (CO), CO_2 , H_2 , and CH_4 ;

(c) methanating the second stream to produce a first OCM reactor feed comprising CH_4 formed from the H_2 and CO and/or CO_2 in the second stream; and

(d) directing the first OCM reactor feed to the OCM reactor.

117. A method for producing hydrocarbon compounds including two or more carbon atoms (C_{2+} compounds), the method comprising:

(a) performing an oxidative coupling of methane (OCM) reaction in an OCM reactor using air as an oxidant to produce an OCM effluent stream comprising carbon dioxide (CO_2), hydrogen (H_2), one or more C_{2+} compounds, and methane (CH_4);

(b) separating the OCM effluent stream into a first stream comprising at least some of the one or more C_{2+} compounds and a second stream comprising carbon monoxide (CO), CO_2 , H_2 , and CH_4 ;

(c) methanating the second stream to produce an OCM reactor feed comprising CH_4 formed from the H_2 and CO and/or CO_2 in the second stream; and

(d) directing the OCM reactor feed to the OCM reactor.

118. A method for producing hydrocarbon compounds including two or more carbon atoms (C_{2+} compounds), the method comprising:

(a) performing an oxidative coupling of methane (OCM) reaction in an OCM reactor using O_2 as an oxidant to produce an OCM effluent stream comprising carbon dioxide (CO_2), hydrogen (H_2), one or more C_{2+} compounds, and methane (CH_4);

(b) separating the OCM effluent stream into a first stream comprising at least some of the one or more C_{2+} compounds and a second stream comprising carbon monoxide (CO), CO_2 , H_2 , and CH_4 ;

(c) methanating the second stream to produce an OCM reactor feed comprising CH_4 formed from the H_2 and CO and/or CO_2 in the second stream; and

(d) directing the OCM reactor feed to the OCM reactor.

119. The method of claim 118, wherein the OCM reactor feed comprises water.

120. A method for producing hydrocarbon compounds including two or more carbon atoms (C_{2+} compounds), the method comprising:

(a) performing an oxidative coupling of methane (OCM) reaction in an OCM reactor to produce an OCM effluent stream comprising carbon dioxide (CO_2), hydrogen (H_2), one or more C_{2+} compounds, and methane (CH_4);

(b) separating the OCM effluent stream into a first stream comprising at least some of the one or more C_{2+} compounds and a second stream comprising carbon monoxide (CO), CO_2 , H_2 , and CH_4 ;

(c) separating the second stream in a pressure swing adsorption (PSA) unit to produce an OCM reactor feed comprising CH_4 and a third stream comprising H_2 and CO and/or CO_2 ; and

(d) directing the OCM reactor feed to the OCM reactor.

121. A method for producing hydrocarbon compounds including two or more carbon atoms (C_{2+} compounds), the method comprising:

(a) performing an oxidative coupling of methane (OCM) reaction in an OCM reactor to produce an OCM effluent stream comprising carbon dioxide (CO_2), hydrogen (H_2), one or more C_{2+} compounds, and methane (CH_4);

(b) separating the OCM effluent stream into a first stream comprising at least some of the one or more C_{2+} compounds and a second stream comprising carbon monoxide (CO), CO_2 , H_2 , and CH_4 ;

(c) separating the second stream in a membrane separation unit to produce an OCM reactor feed comprising CH_4 and a third stream comprising H_2 and CO and/or CO_2 ; and

(d) directing the OCM reactor feed to the OCM reactor.

122. A method for producing hydrocarbon compounds including two or more carbon atoms (C_{2+} compounds), the method comprising:

(a) performing an oxidative coupling of methane (OCM) reaction in an OCM reactor to produce an OCM effluent stream comprising carbon dioxide (CO_2), hydrogen (H_2), one or more C_{2+} compounds, and methane (CH_4);

(b) separating the OCM effluent stream in a pressure swing adsorption (PSA) unit into a first stream comprising at least some of the one or more C_{2+} compounds and CH_4 and a second stream comprising carbon monoxide (CO), CO_2 , and H_2 ;

(c) separating the first stream in a demethanizer unit to produce an OCM reactor feed comprising CH_4 and a third stream comprising the at least some of the one or more C_{2+} compounds; and

(d) directing the OCM reactor feed to the OCM reactor.

123. A method for producing hydrocarbon compounds including two or more carbon atoms (C_{2+} compounds), the method comprising:

(a) performing an oxidative coupling of methane (OCM) reaction in an OCM reactor to produce an OCM effluent stream comprising carbon dioxide (CO_2), hydrogen (H_2), one or more C_{2+} compounds, and methane (CH_4);

(b) separating the OCM effluent stream in a pressure swing adsorption (PSA) unit into a first stream comprising CH_4 and a second stream comprising at least some of the one or more C_{2+} compounds, carbon monoxide (CO), CO_2 , and H_2 ;

(c) separating the second stream to produce a third stream comprising the at least some of the one or more C₂₊ compounds and a fourth stream comprising carbon monoxide (CO), CO₂, and H₂; and

(d) directing the first stream to the OCM reactor.

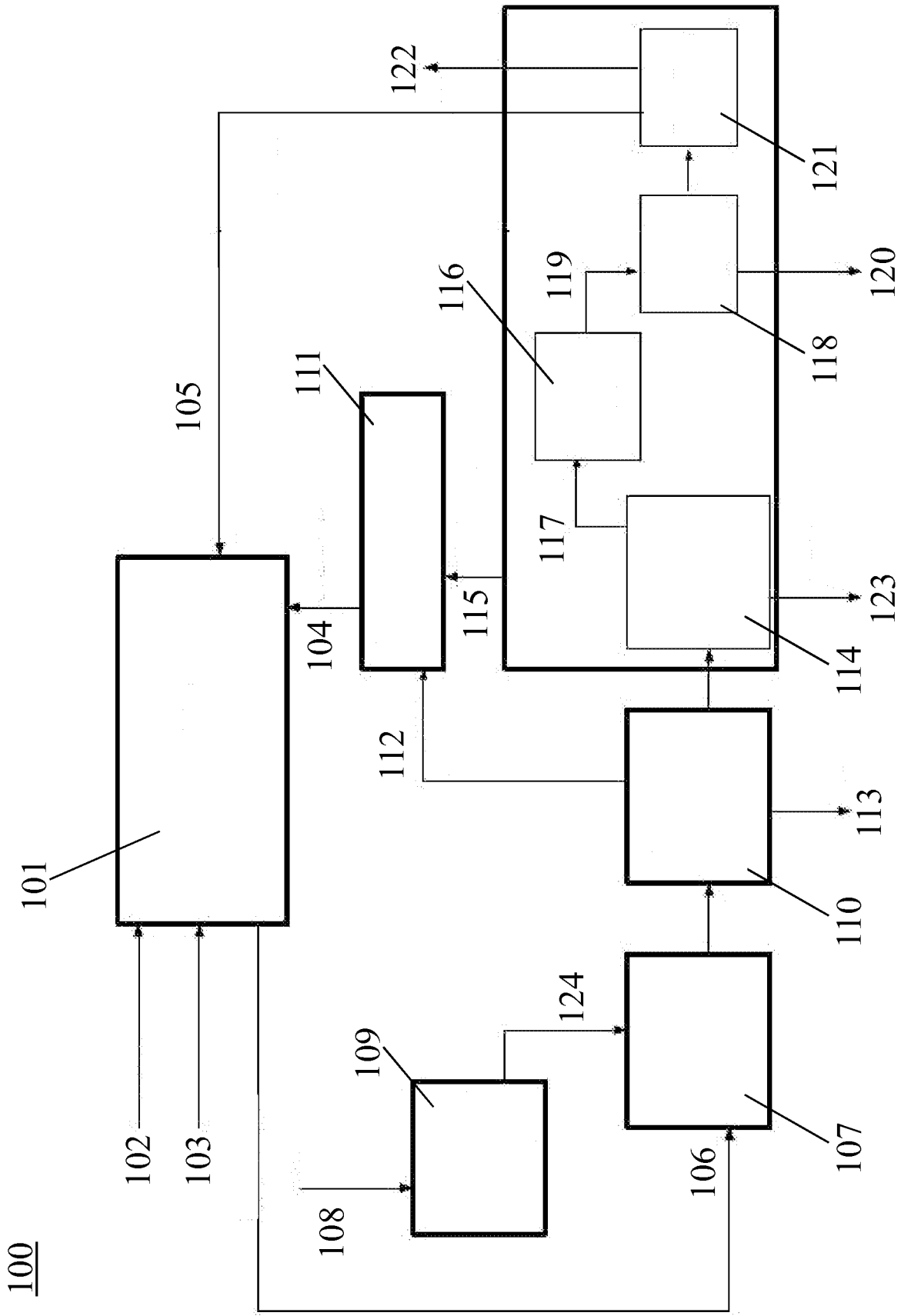

FIG. 1

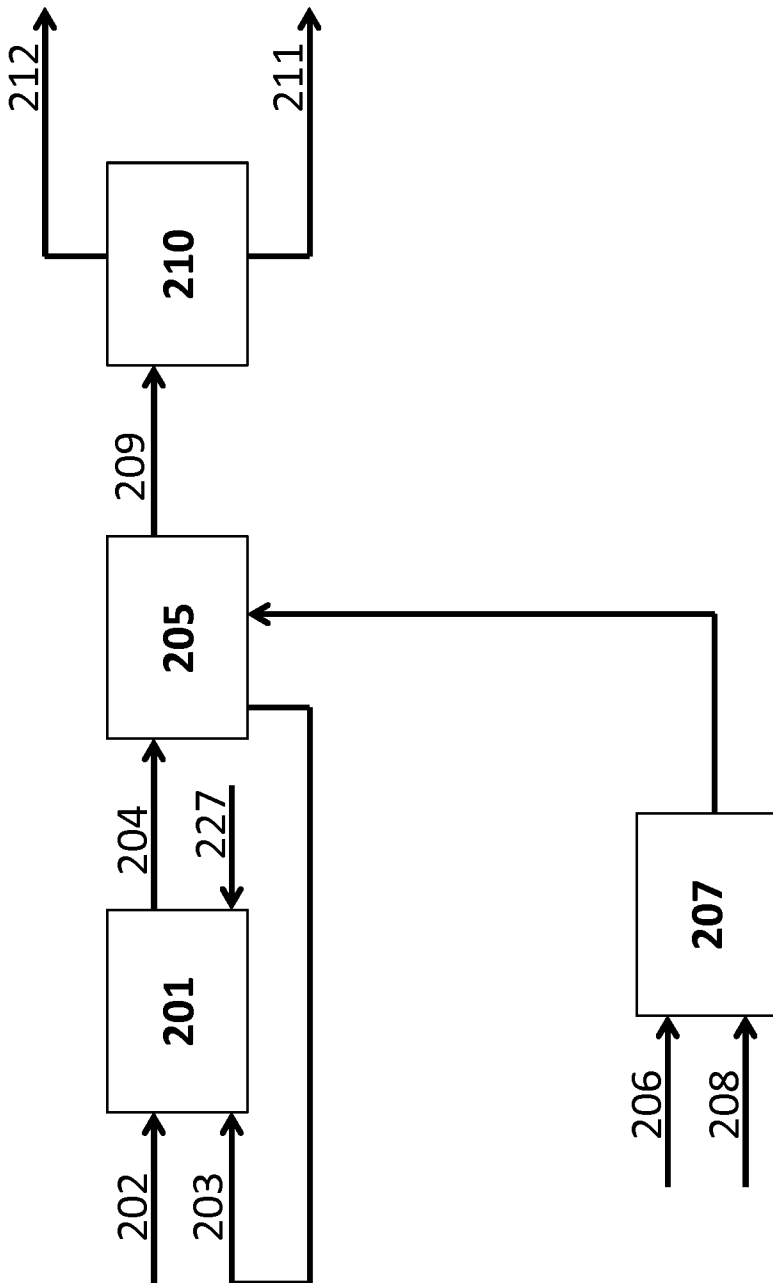

FIG. 2A

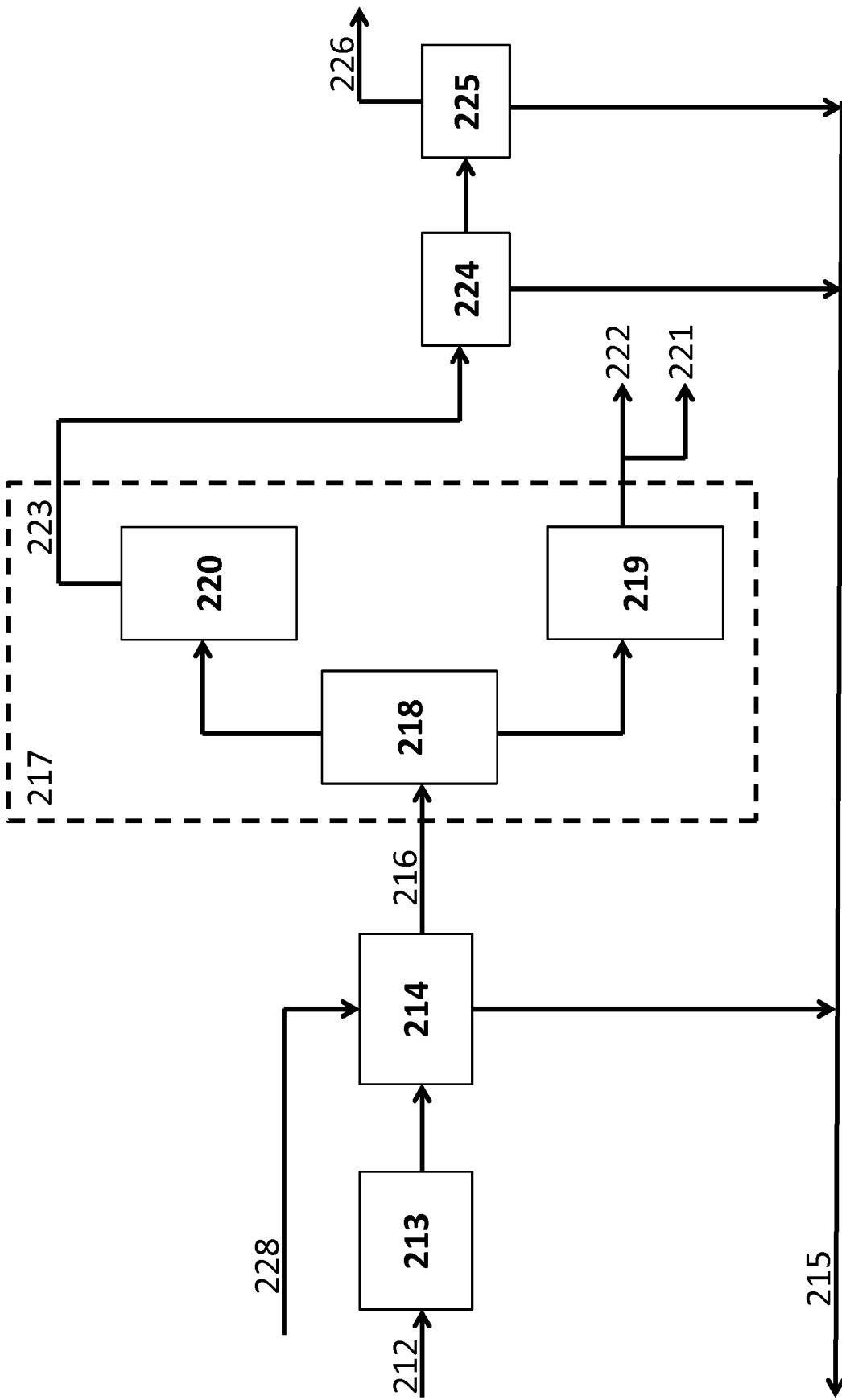

FIG. 2B

300

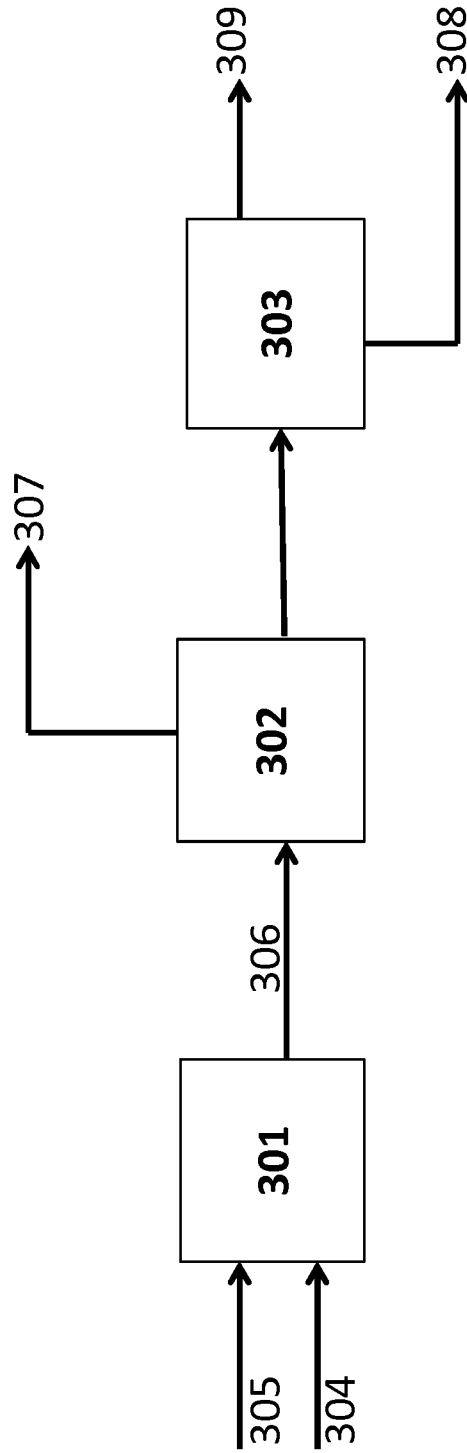

FIG. 3

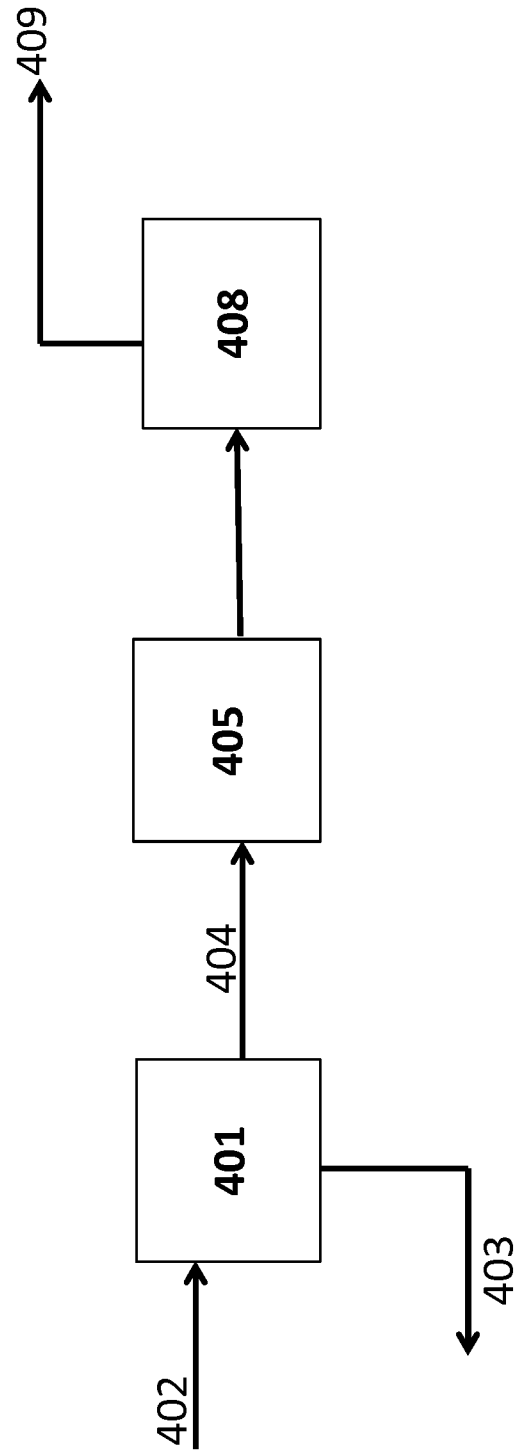

FIG. 4

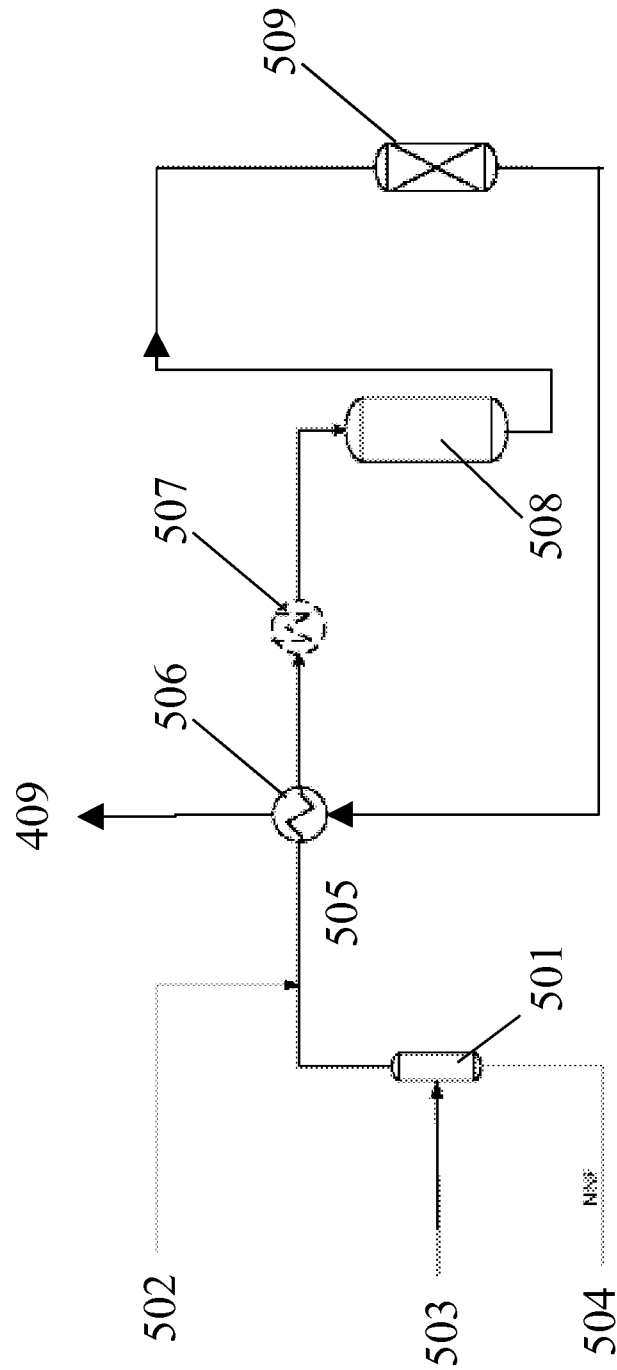

FIG. 5

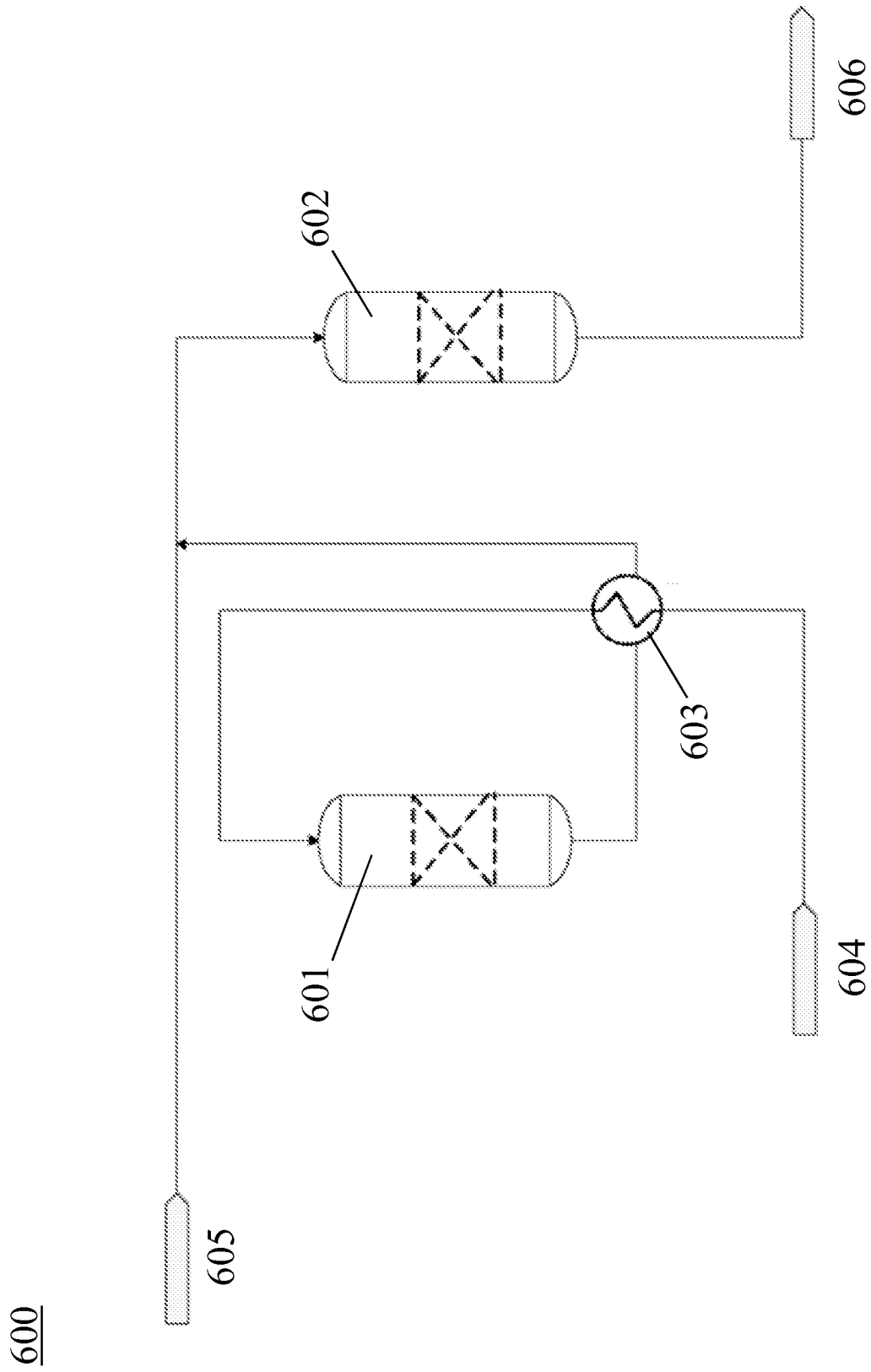

FIG. 6A

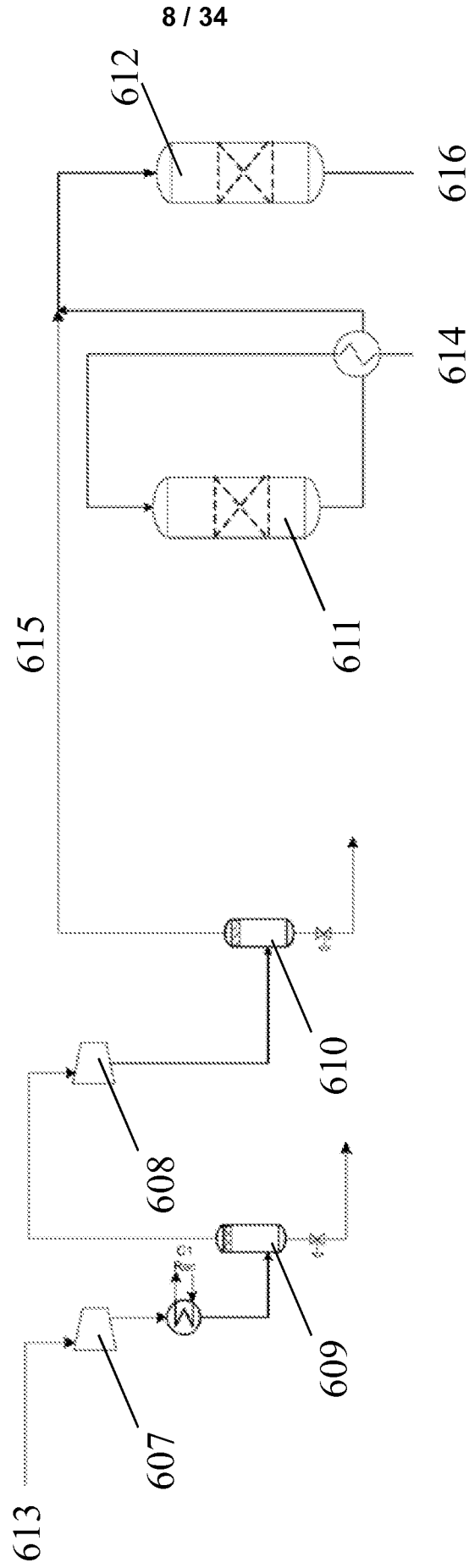

FIG. 6B

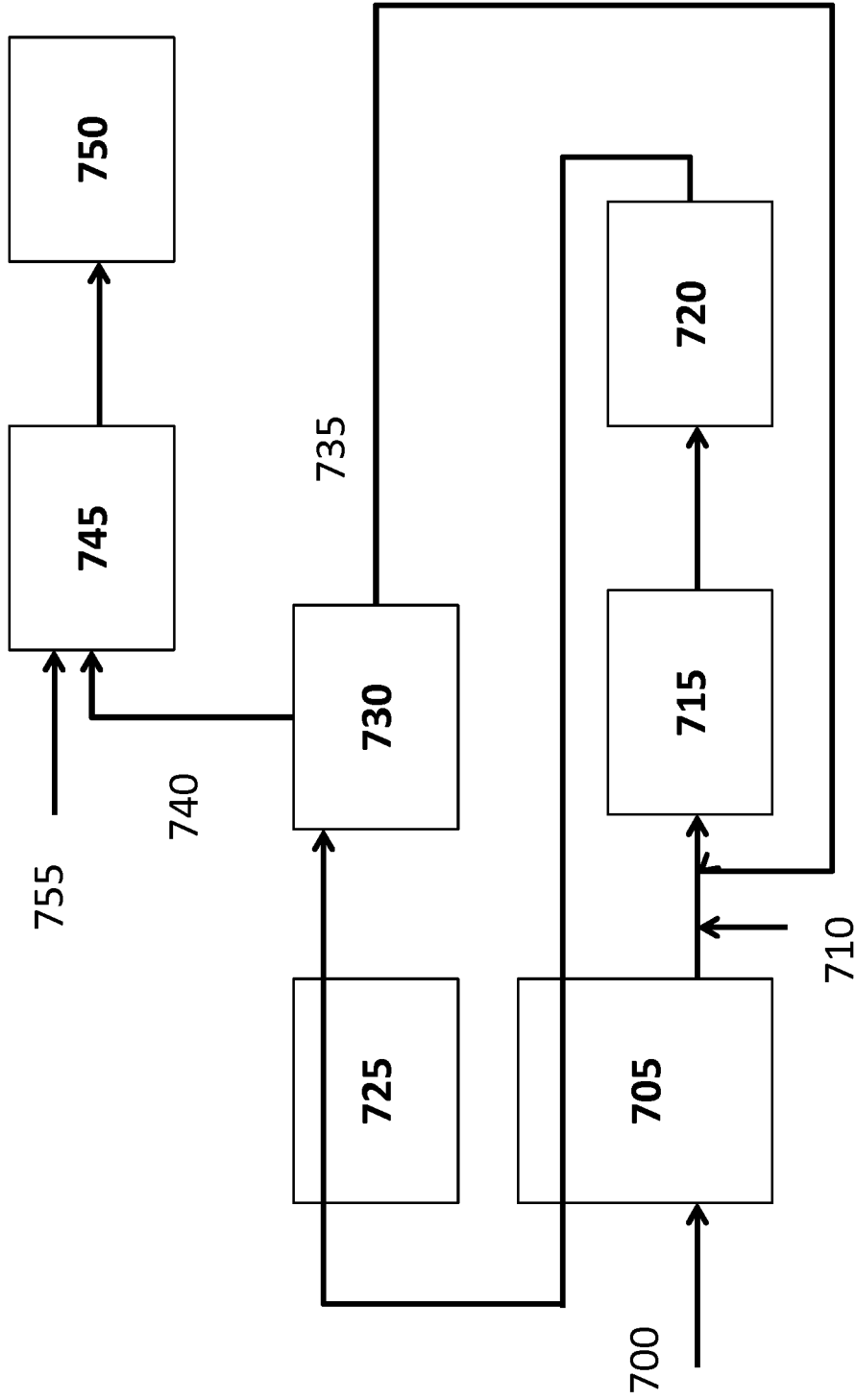

FIG. 7

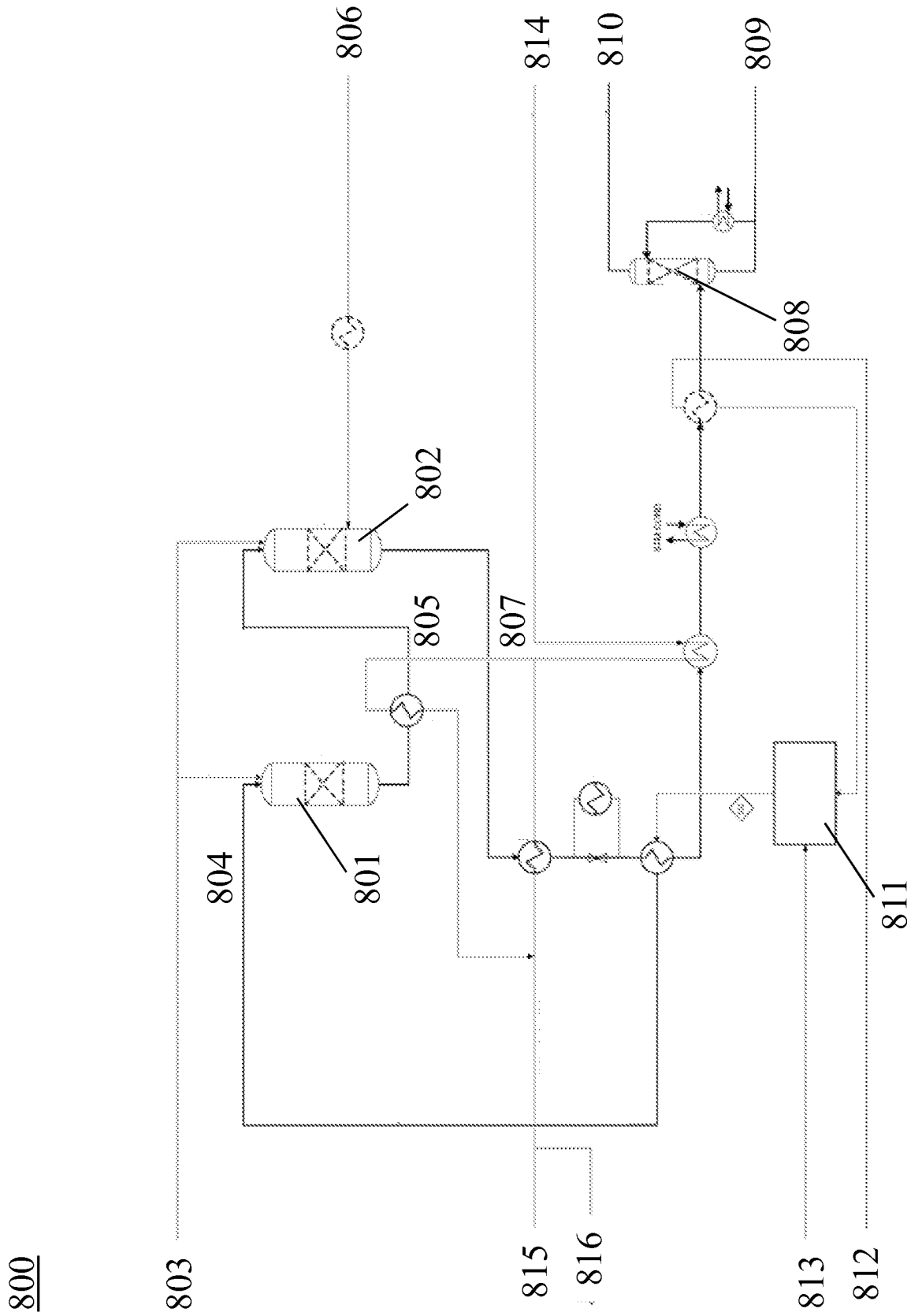

FIG. 8A

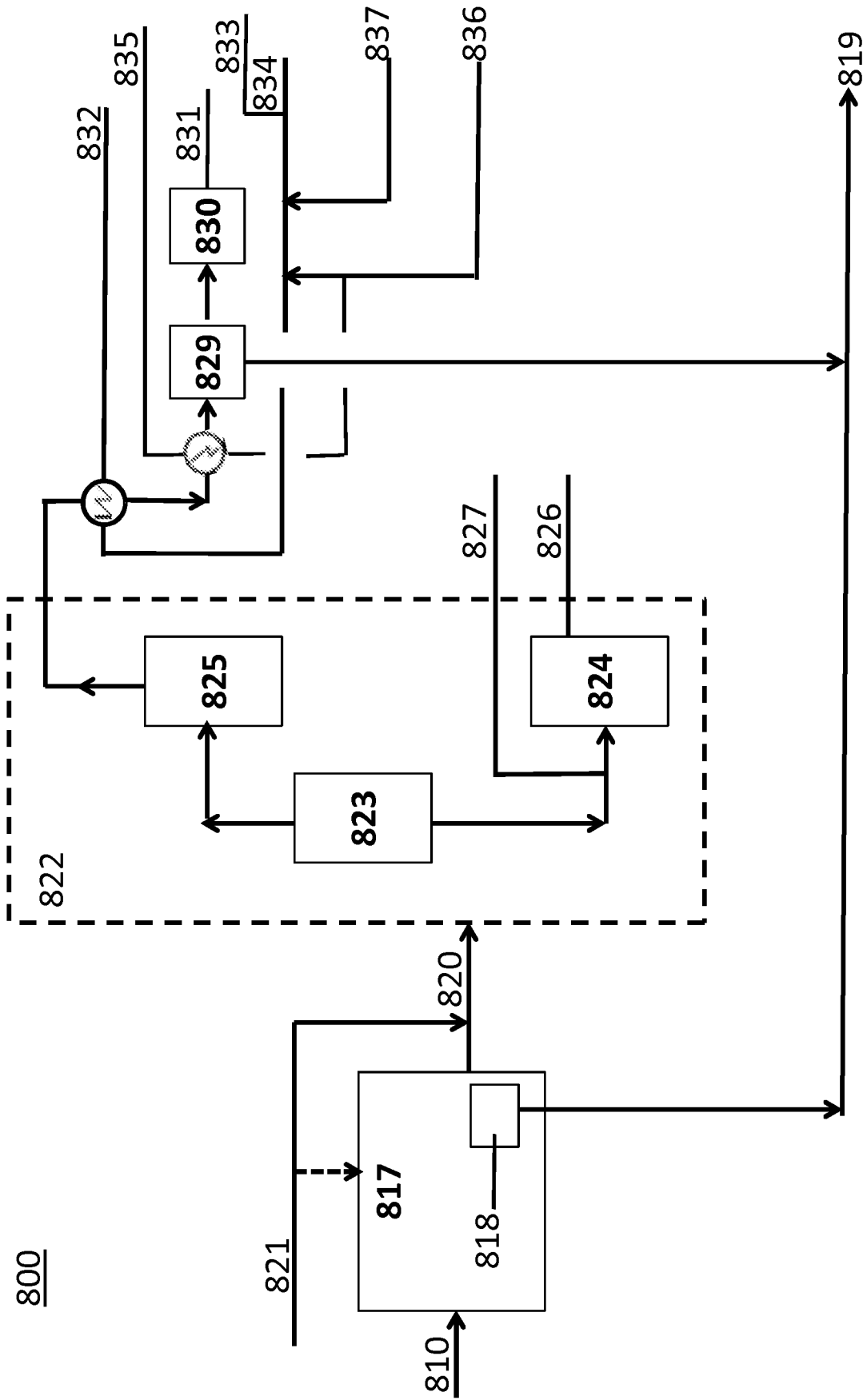

FIG. 8B

900

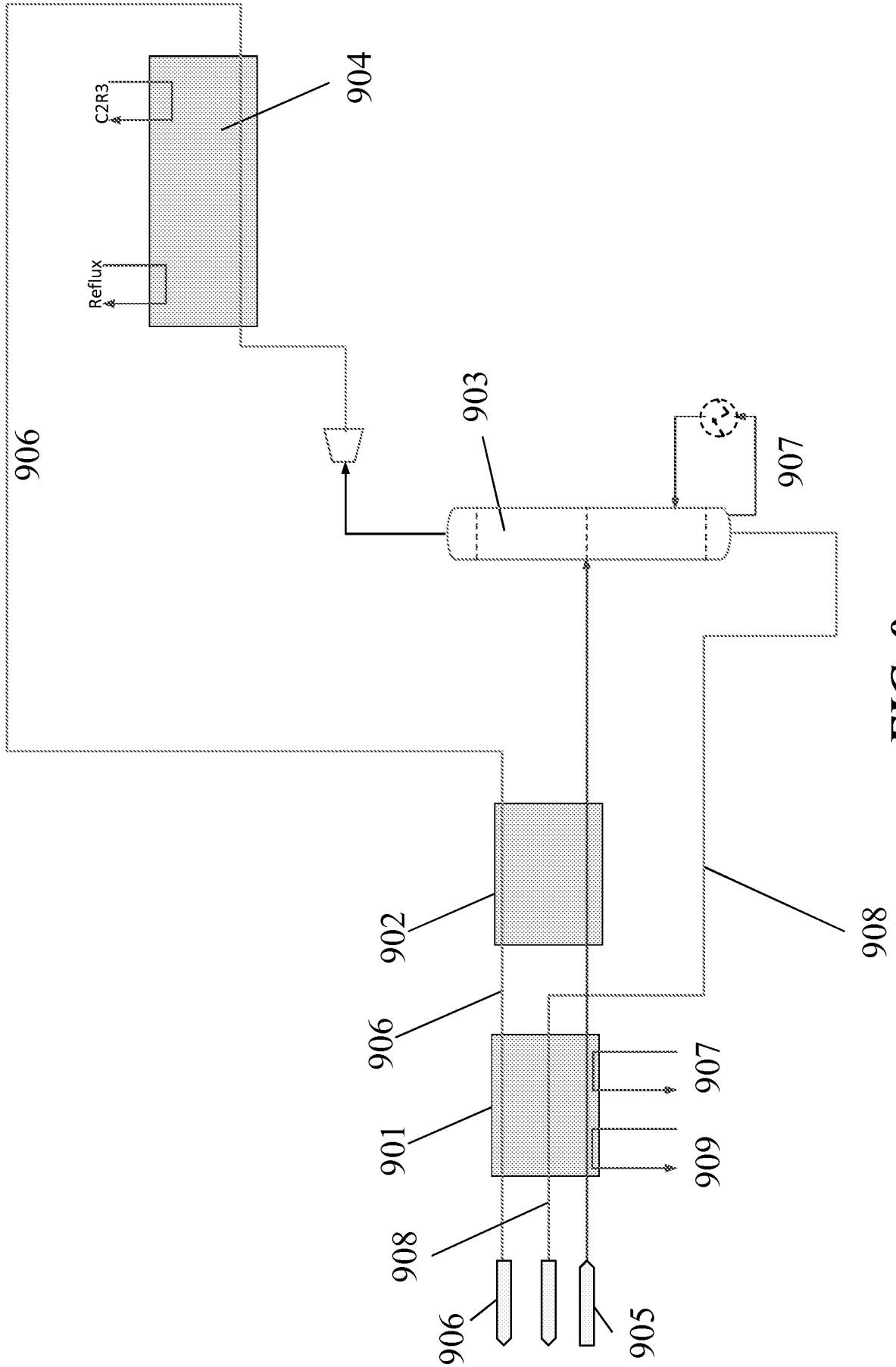

FIG. 9

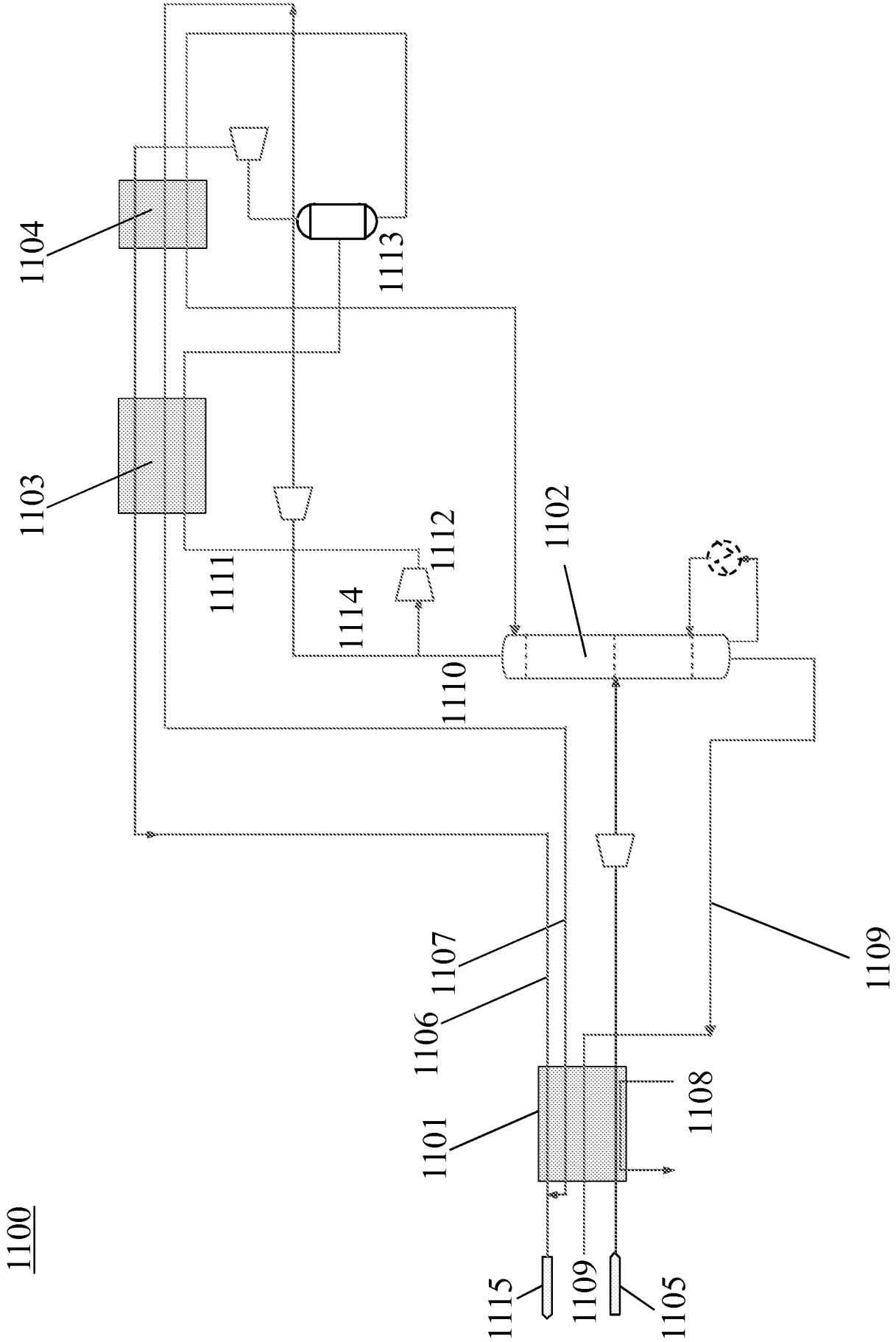

FIG. 11

1200

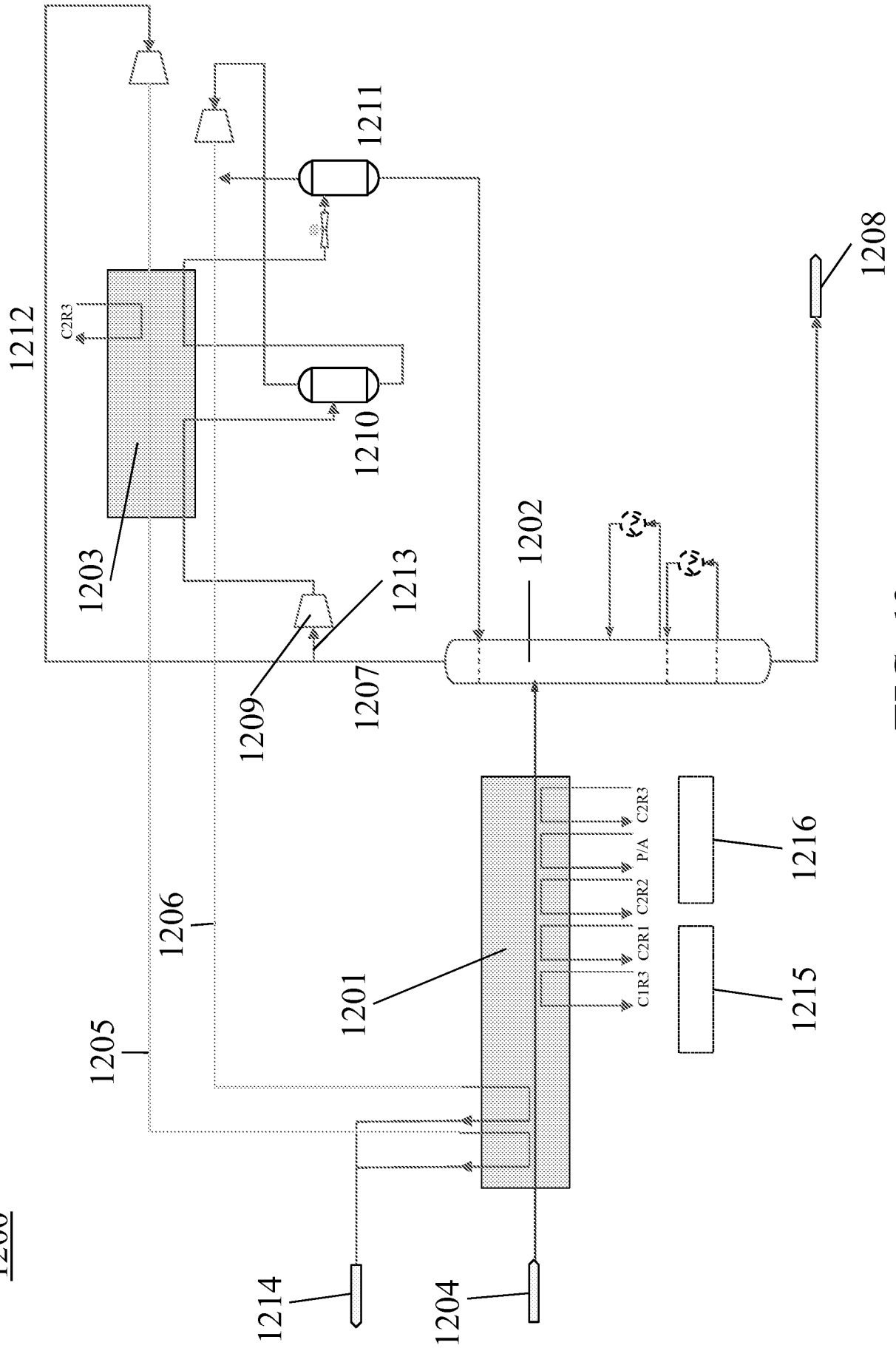

FIG. 12

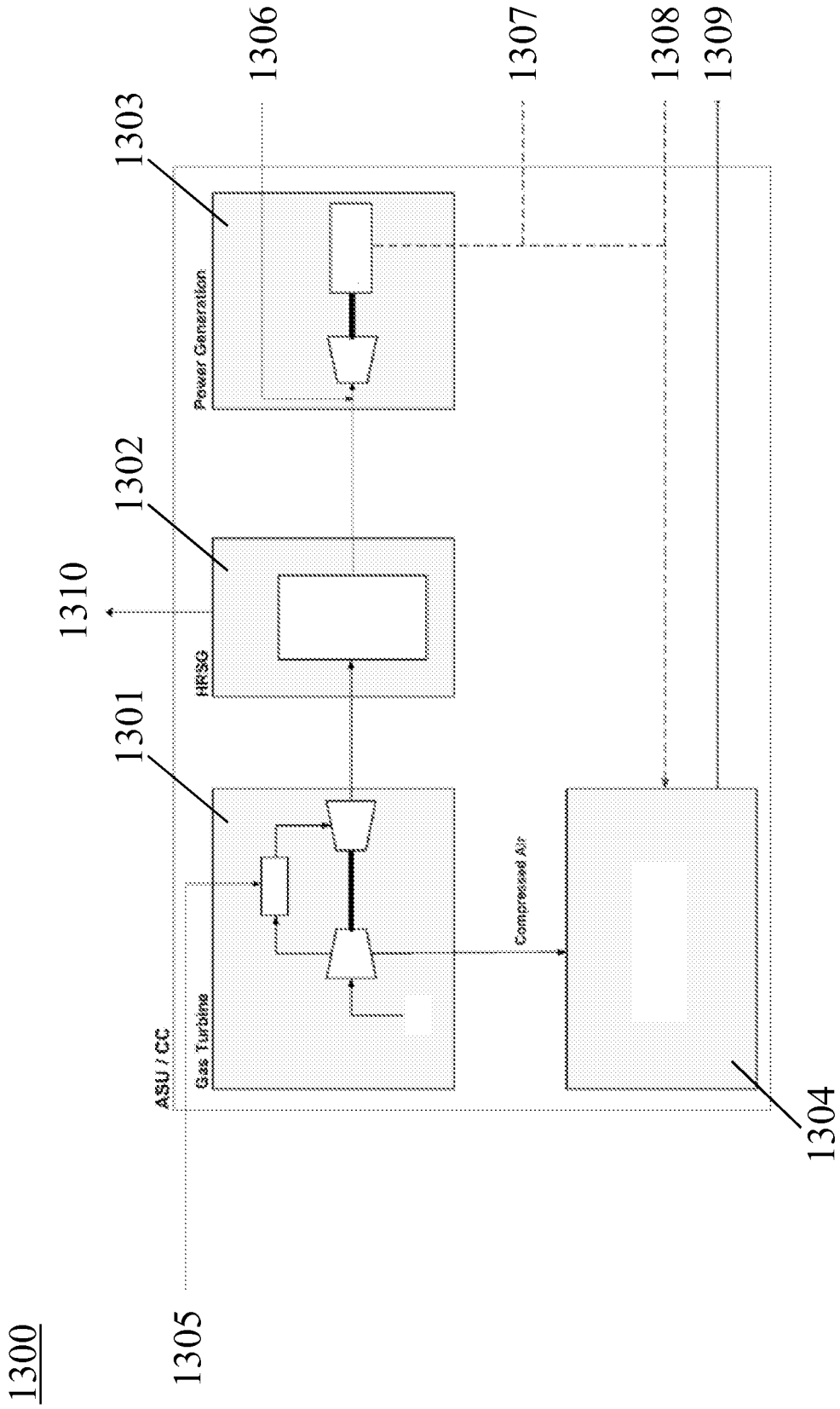

FIG. 13

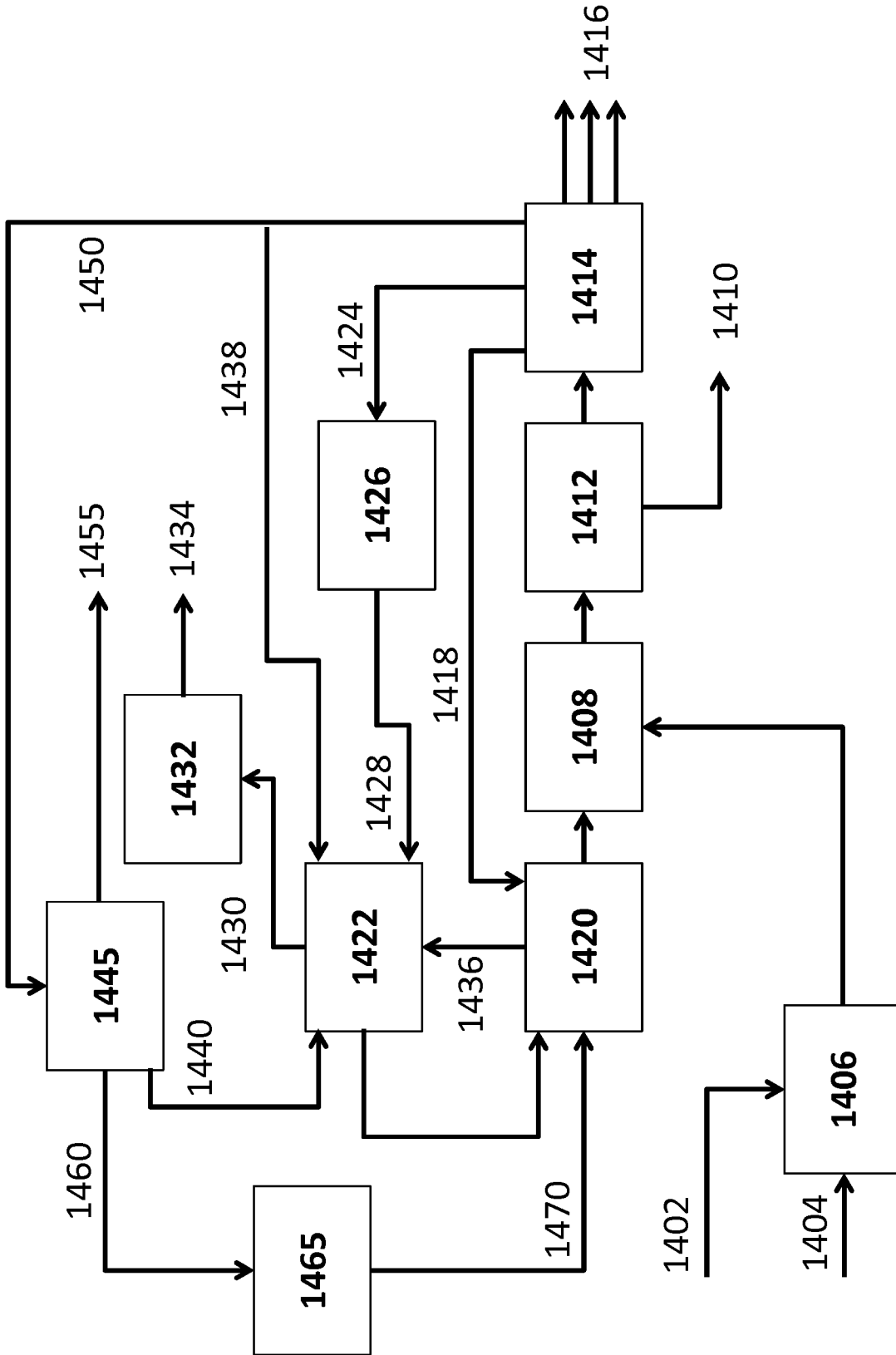

FIG. 14

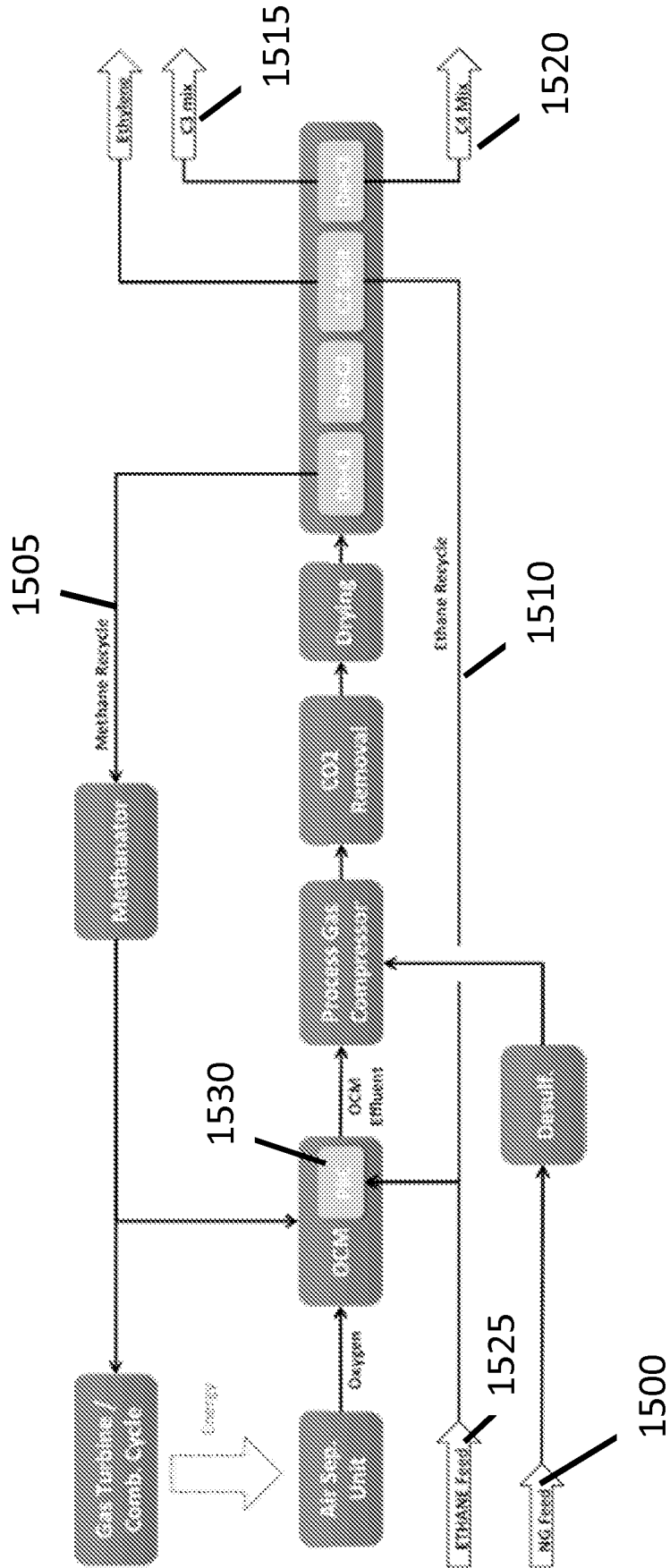

FIG. 15

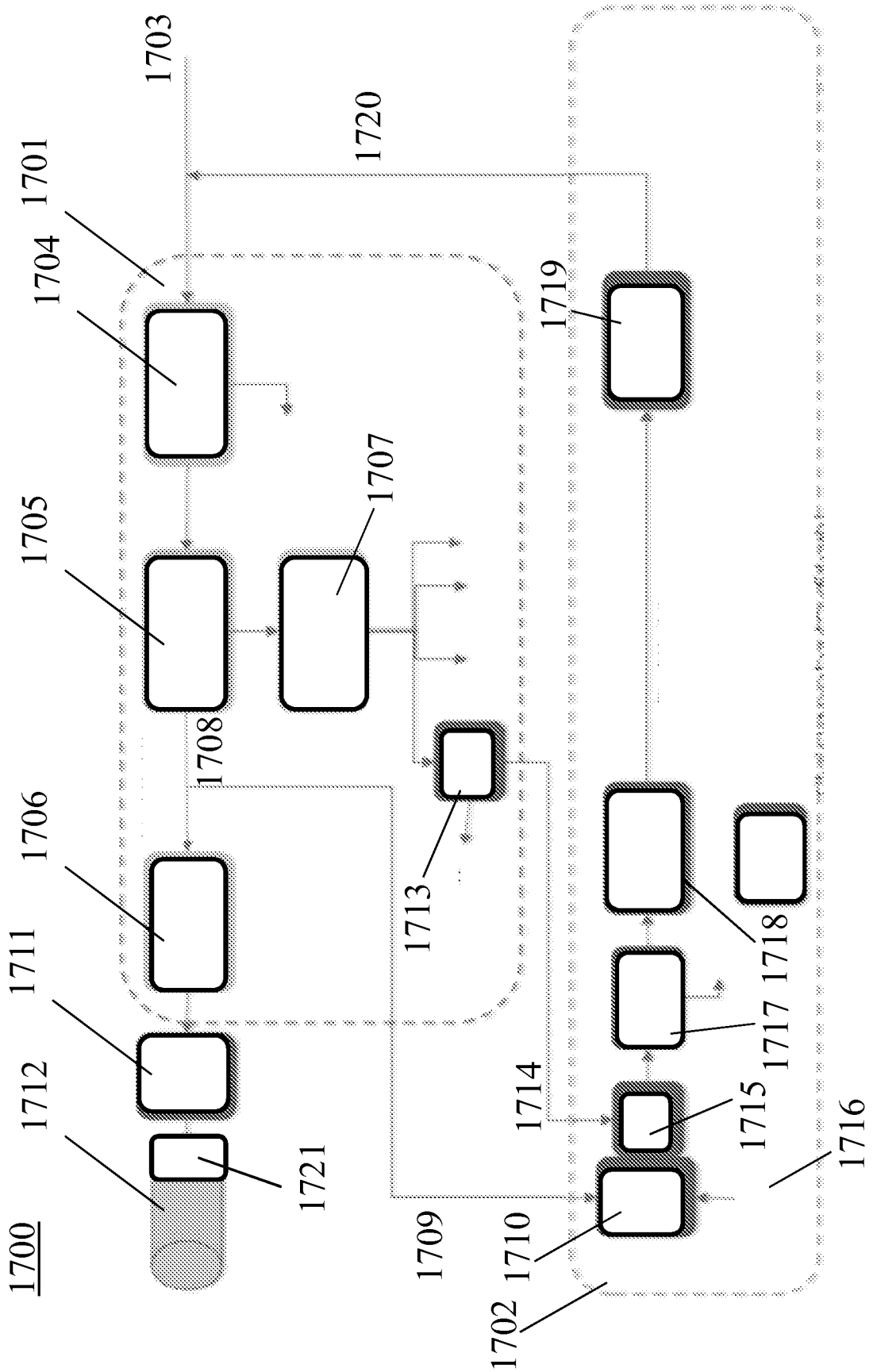

FIG. 17

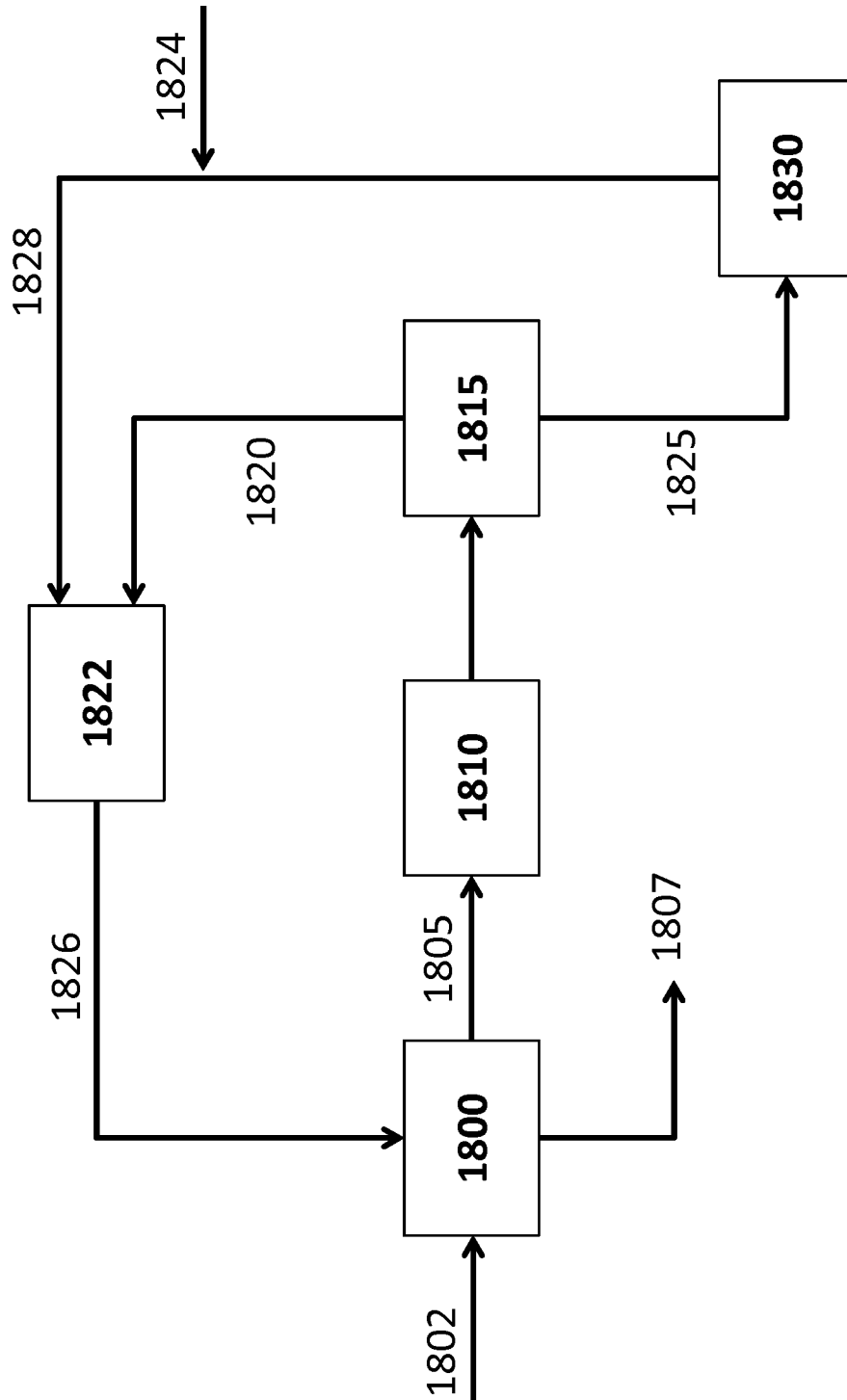

FIG. 18

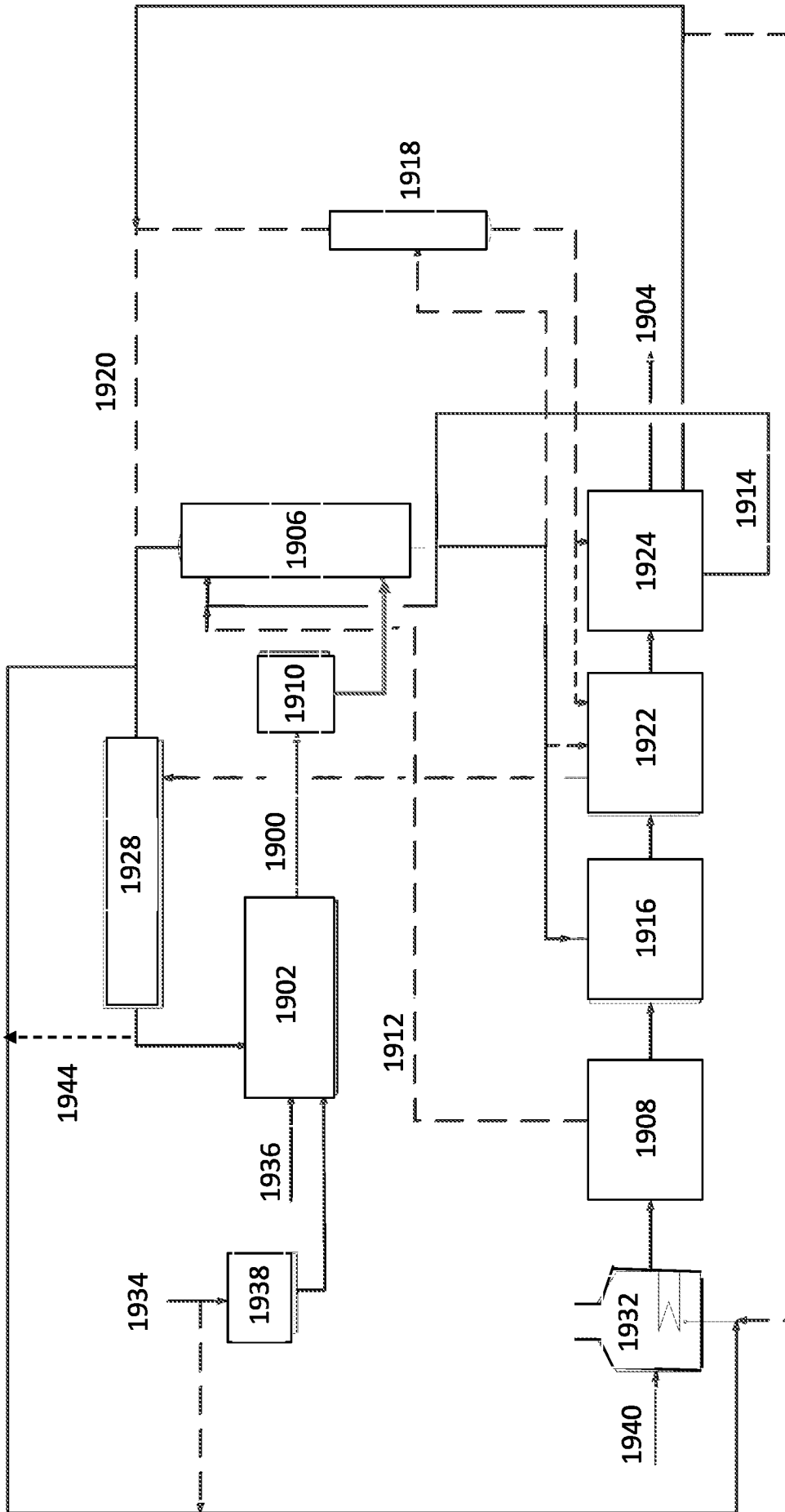

FIG. 19

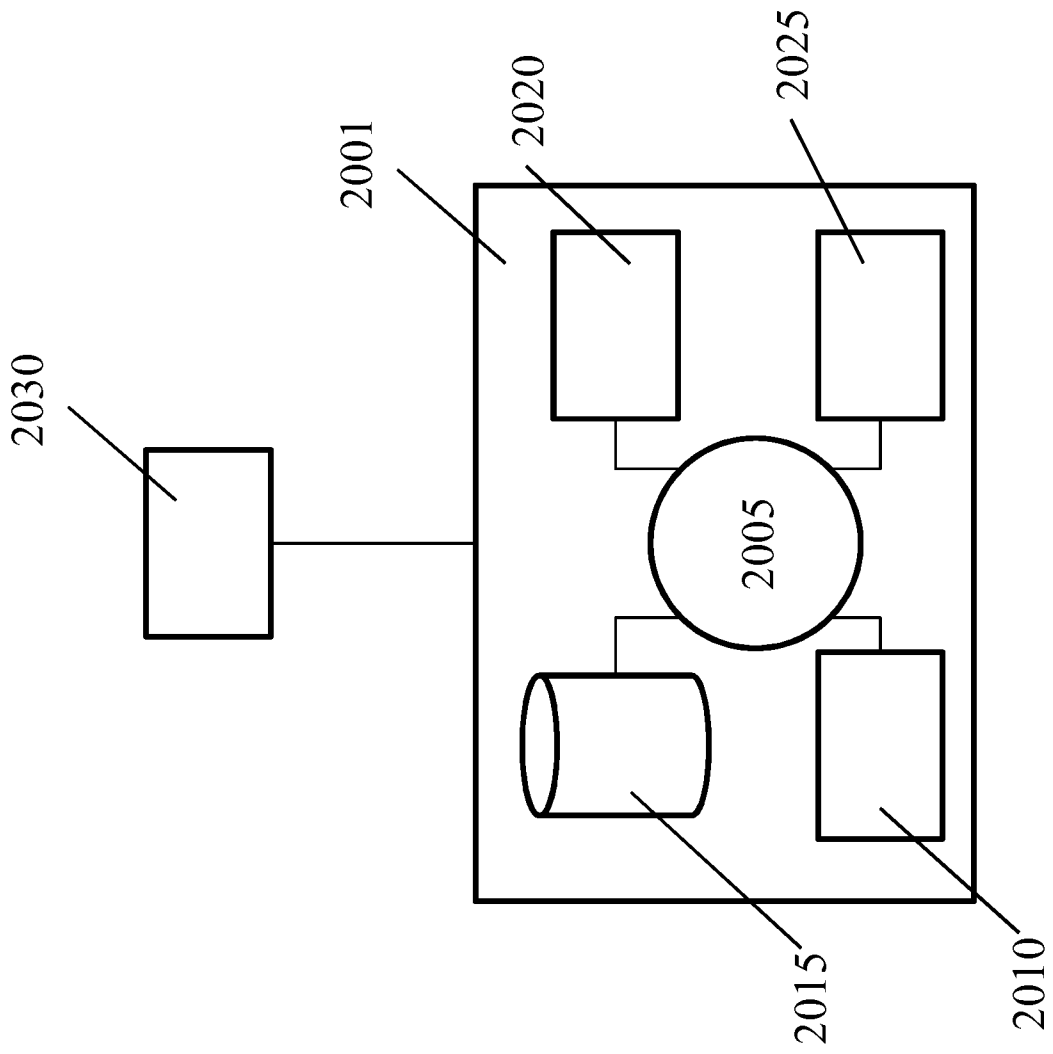

FIG. 20

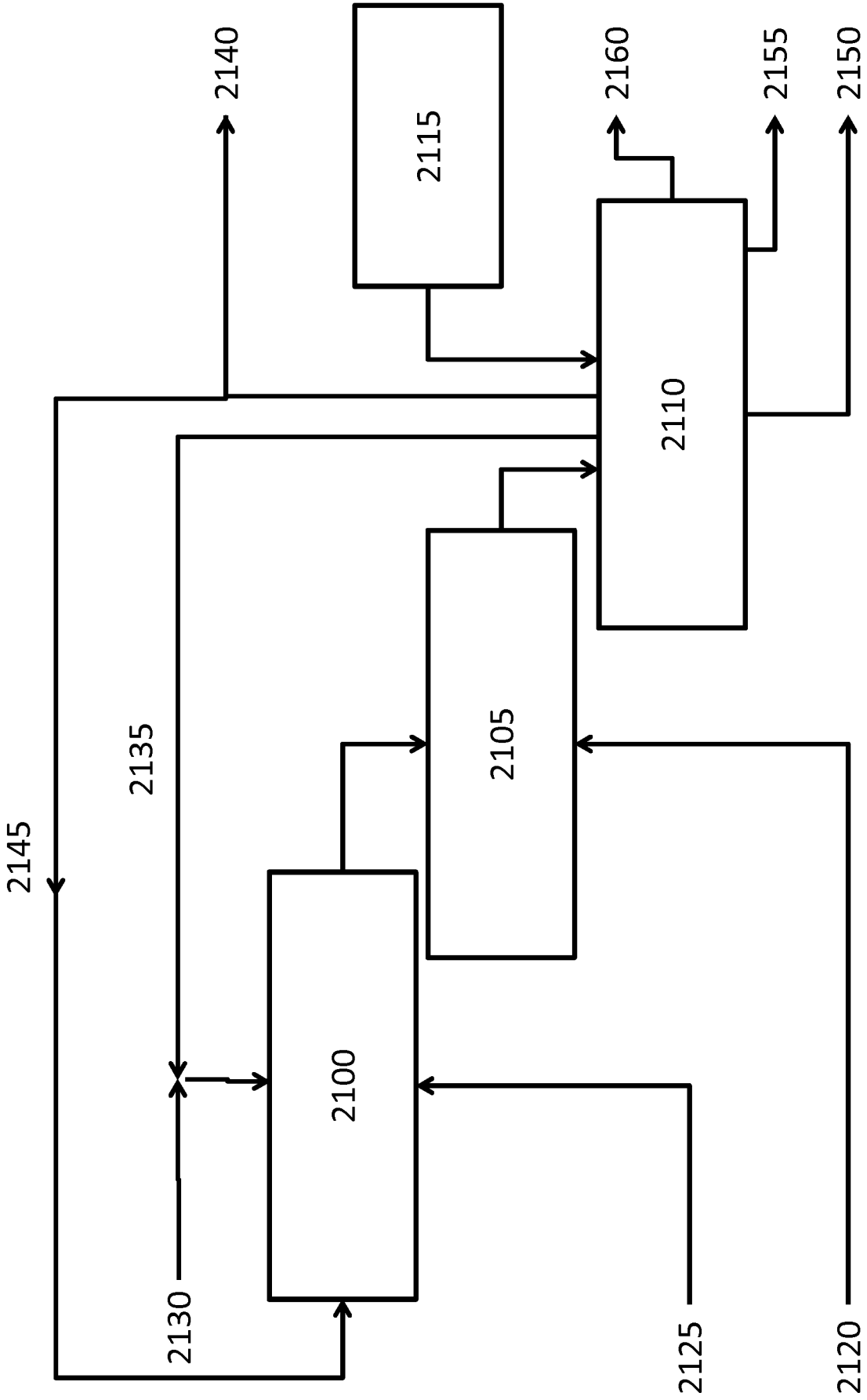

FIG. 21

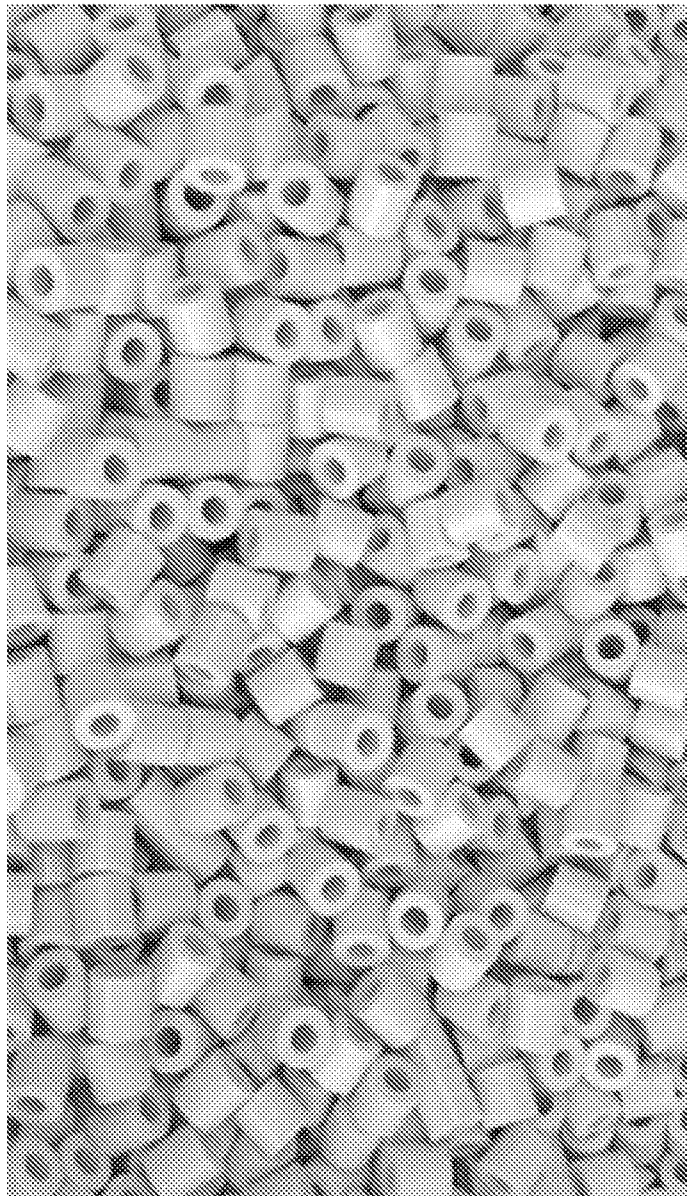

FIG. 22

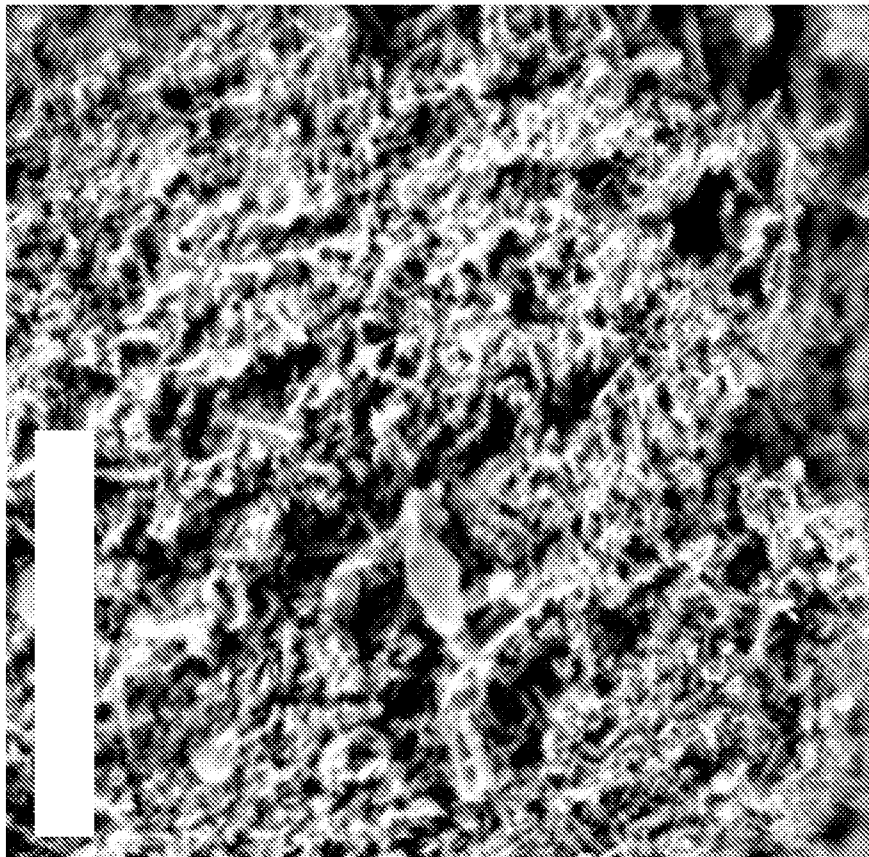

FIG. 23

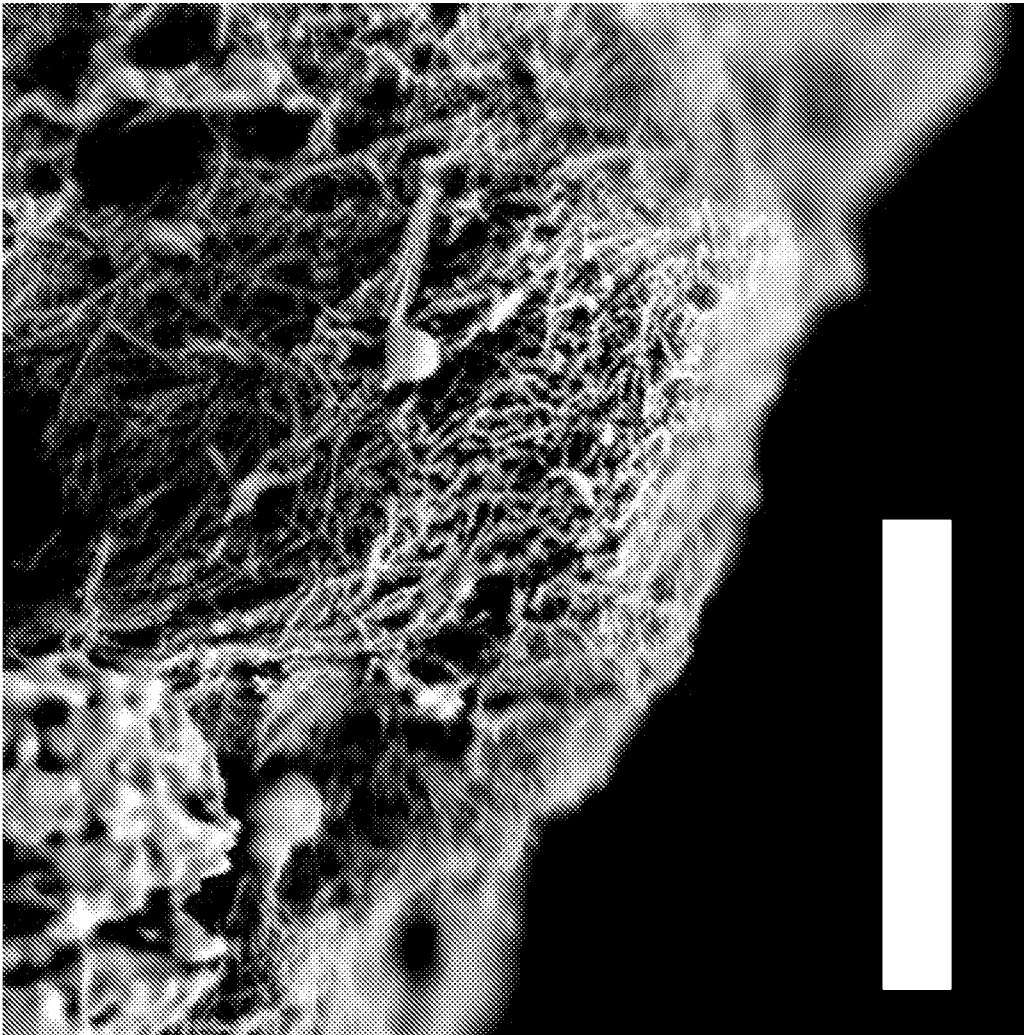

FIG. 24

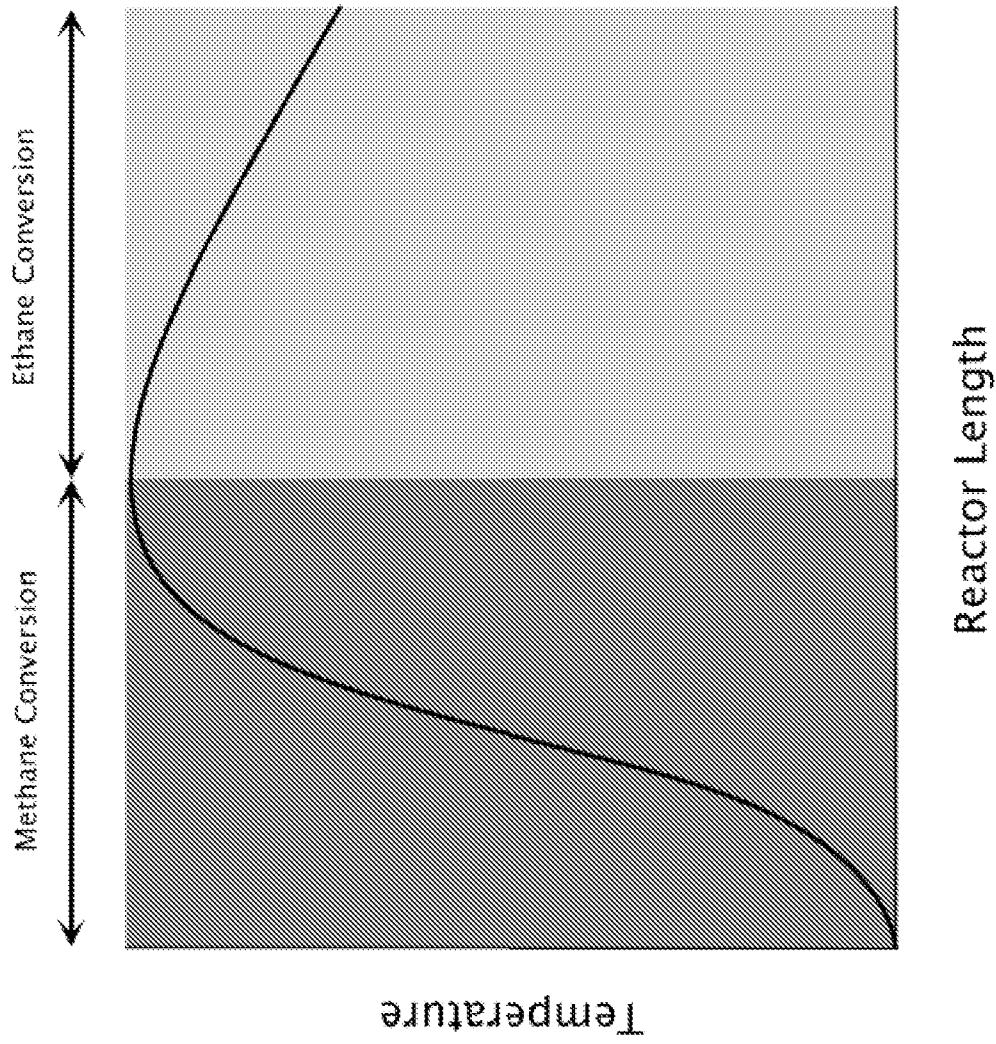

FIG. 25

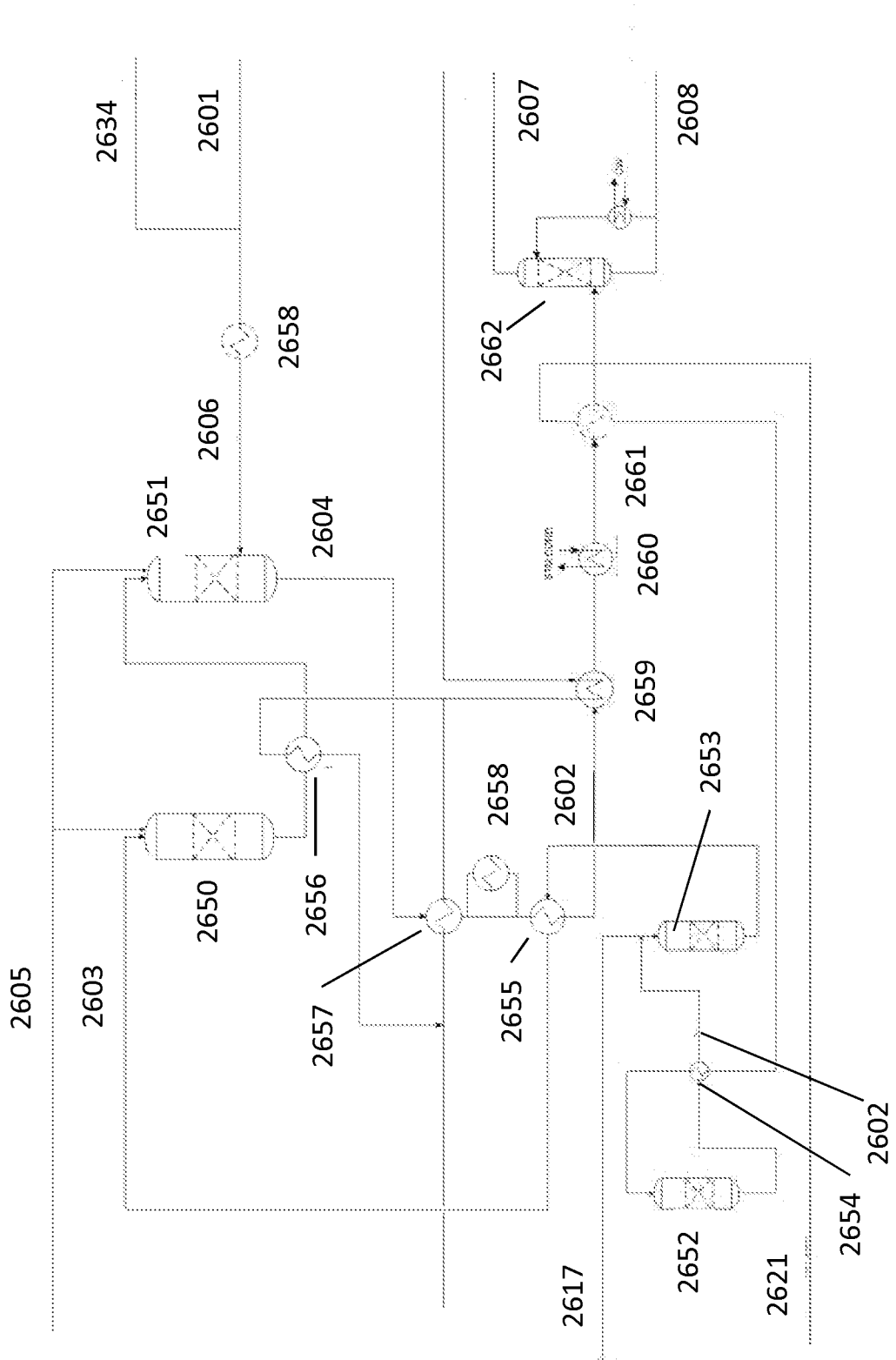

FIG. 26

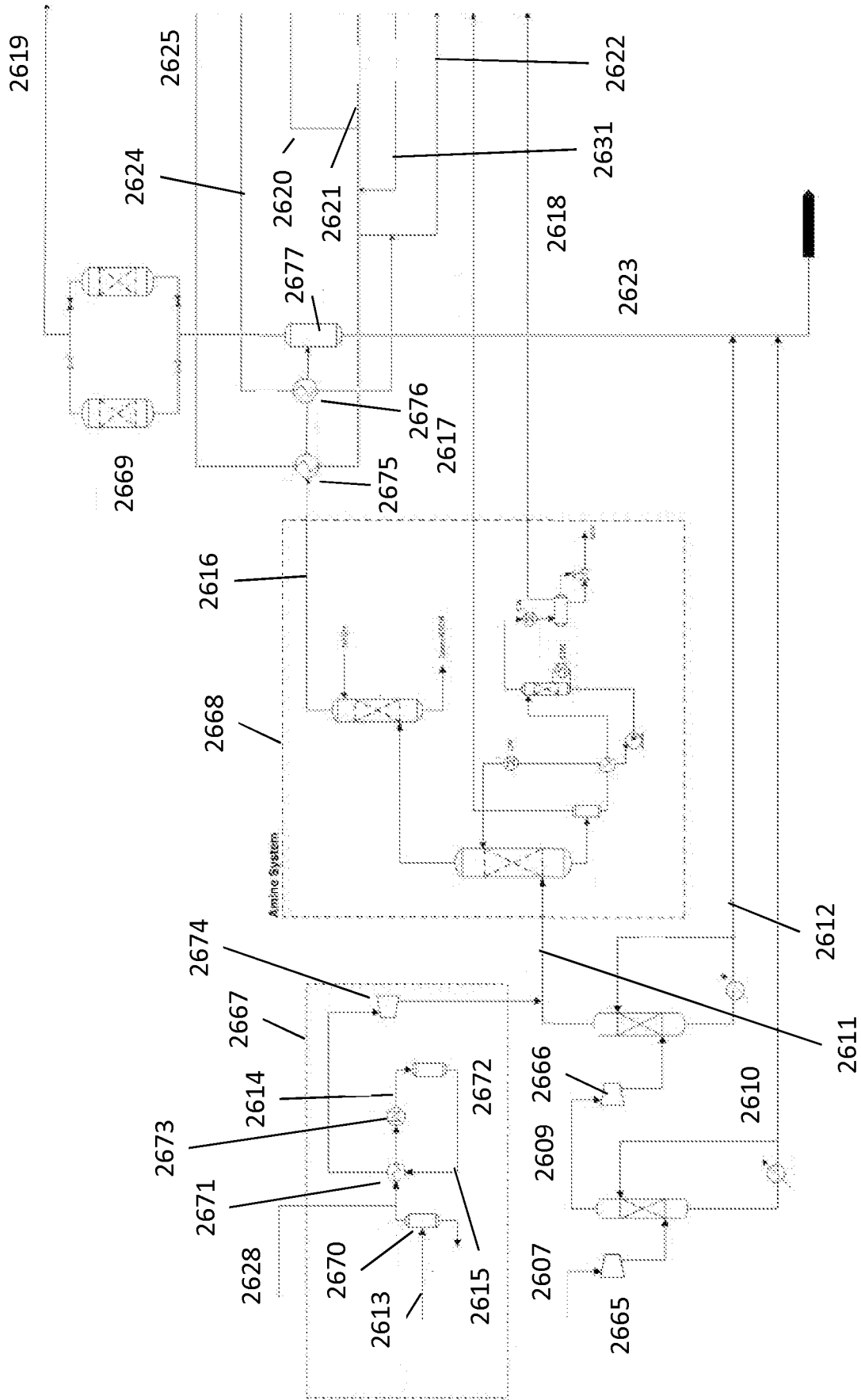

FIG. 27

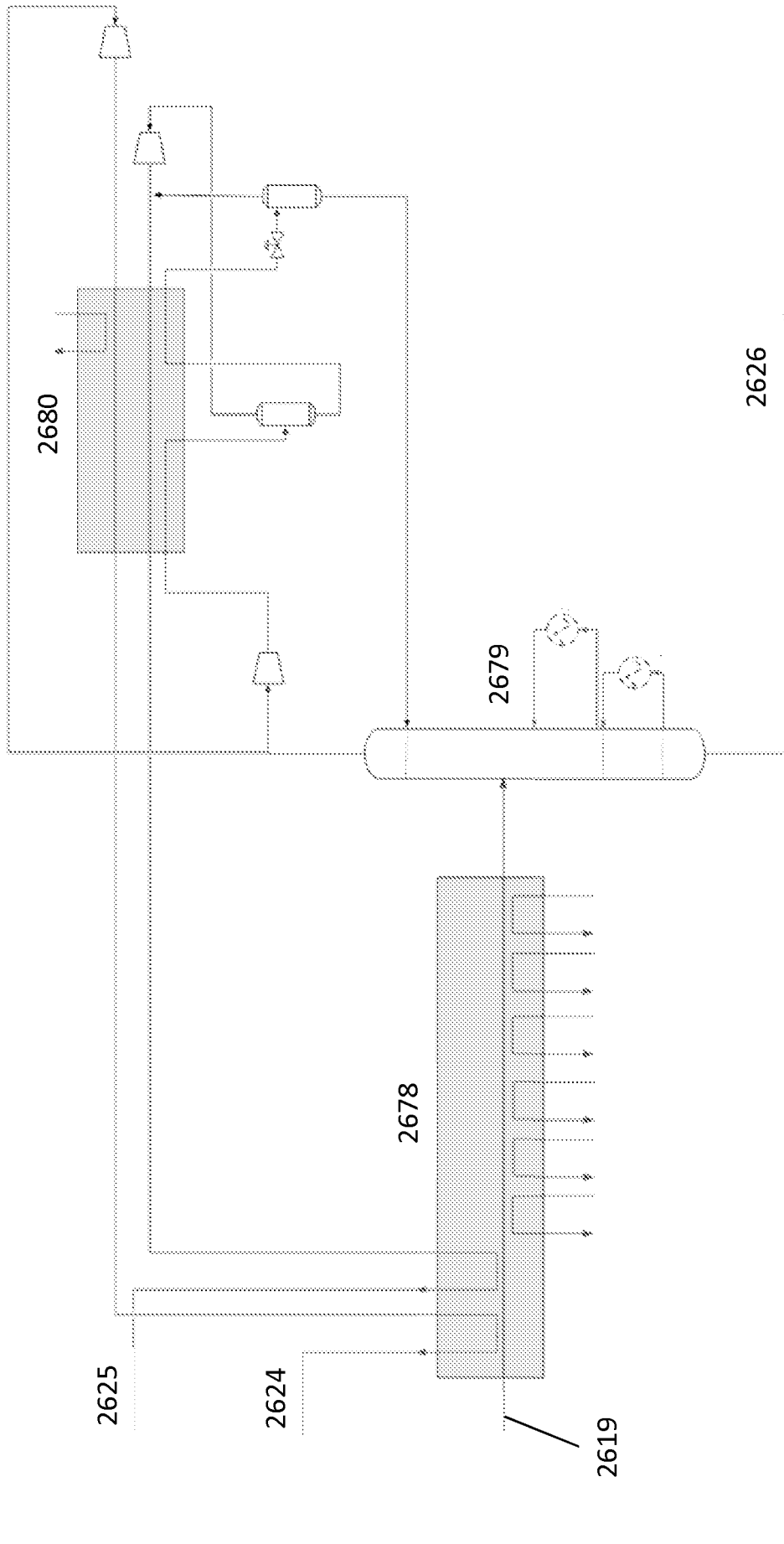

FIG. 28

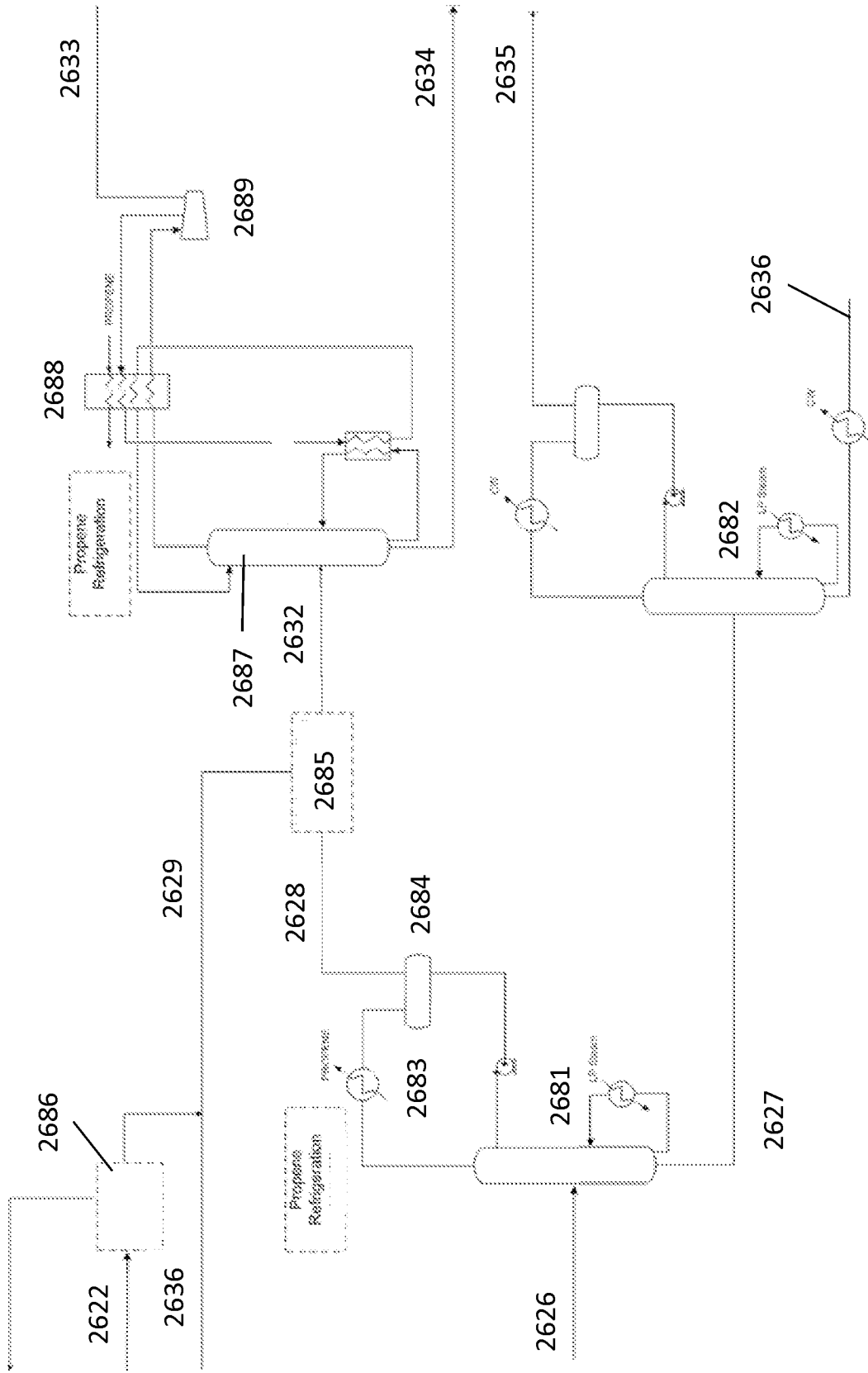

FIG. 29

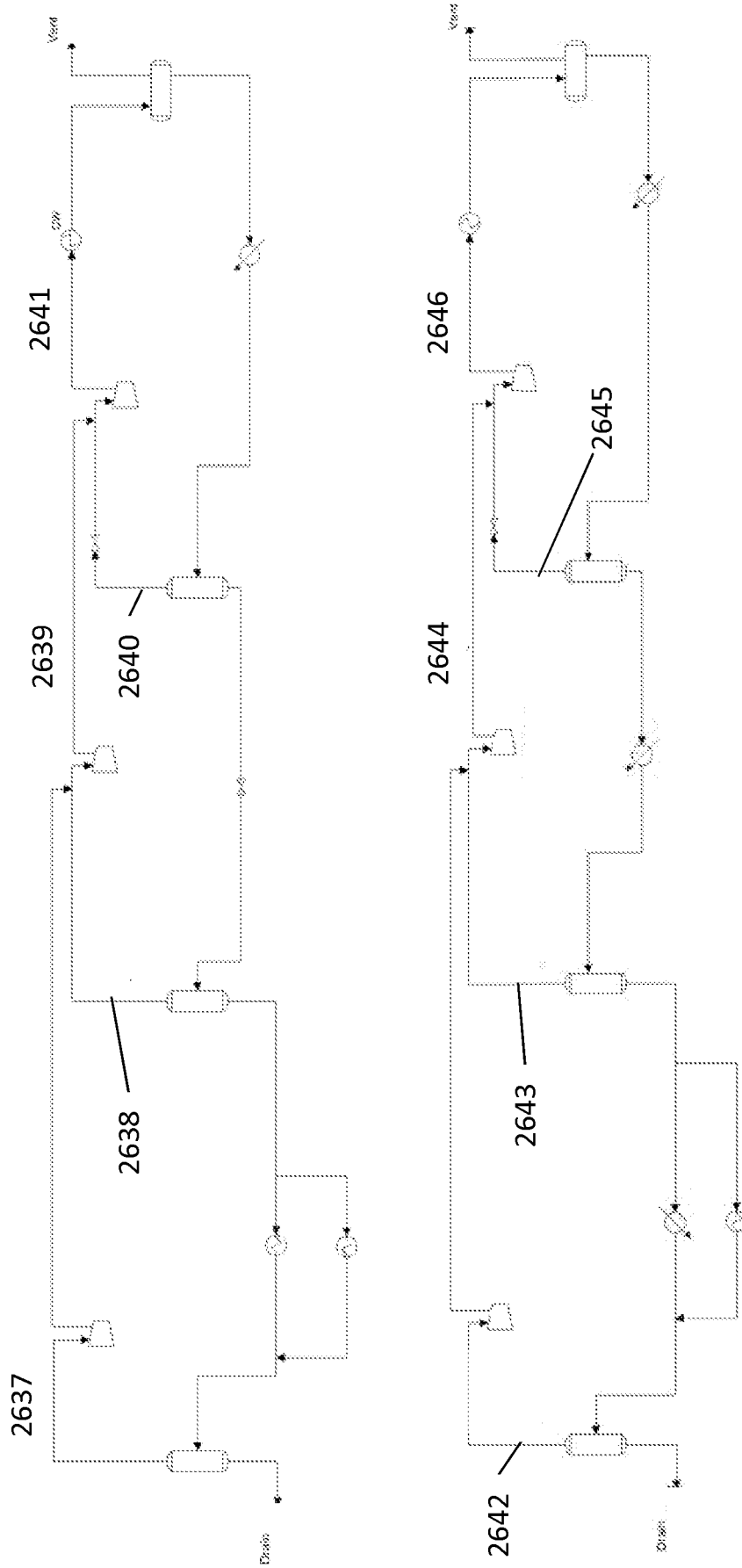

FIG. 30

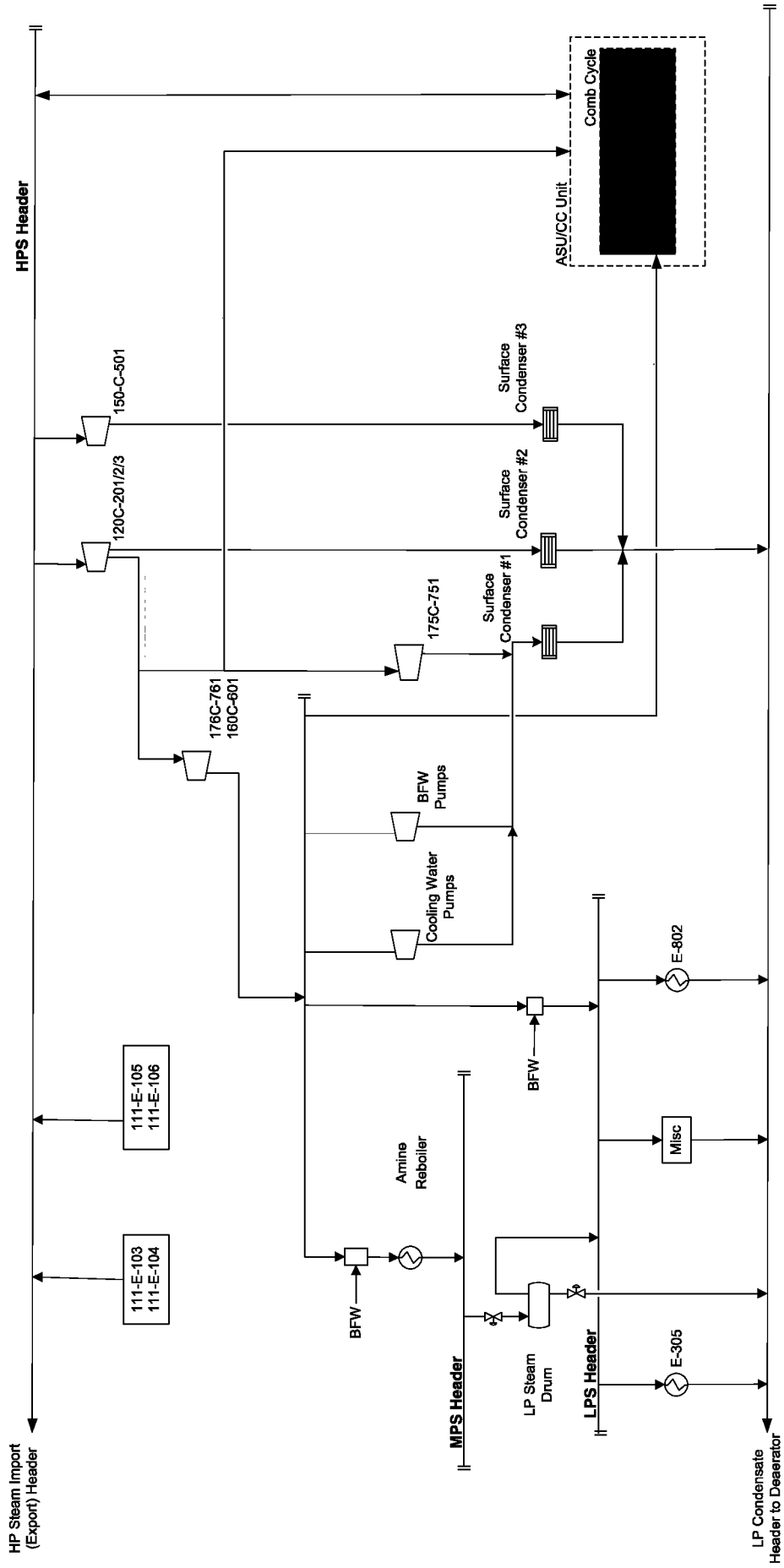

FIG. 31

INTERNATIONAL SEARCH REPORT

International application No.
PCT/US2015/010688**A. CLASSIFICATION OF SUBJECT MATTER****C07C 2/82(2006.01)i, C07C 2/84(2006.01)i, C07C 2/08(2006.01)i**

According to International Patent Classification (IPC) or to both national classification and IPC

B. FIELDS SEARCHEDMinimum documentation searched (classification system followed by classification symbols)
C07C 2/82; C07C 5/327; C07C 2/00; C07C 2/84; C07C 5/333; C07C 2/08Documentation searched other than minimum documentation to the extent that such documents are included in the fields searched
Korean utility models and applications for utility models
Japanese utility models and applications for utility modelsElectronic data base consulted during the international search (name of data base and, where practicable, search terms used)
eKOMPASS(KIPO internal) & Keywords: oxidative coupling of methane(OCM), olefins, methane, oxidizing agent, first heat exchanger, second heat exchanger, H2, CO, CO2, nitrogen(N2), oxygen(O2), water(H2O), argon(Ar)**C. DOCUMENTS CONSIDERED TO BE RELEVANT**

Category*	Citation of document, with indication, where appropriate, of the relevant passages	Relevant to claim No.
A	US 2013-0225884 A1 (SILURIA TECHNOLOGIES, INC.) 29 August 2013 See abstract and claims 1-27.	1-16
A	US 6518476 B1 (UNION CARBIDE CHEMICALS & PLASTICS TECHNOLOGY CORPORATION) 11 February 2003 See abstract and claims 1-31.	1-16
A	WO 2011-008464 A1 (FINA TECHNOLOGY, INC.) 20 January 2011 See claims 1-20.	1-16
A	US 05430219 A (SNAMPROGETTI S.p.A. et al.) 04 July 1995 See claims 1-15.	1-16

 Further documents are listed in the continuation of Box C. See patent family annex.

* Special categories of cited documents:

"A" document defining the general state of the art which is not considered to be of particular relevance

"E" earlier application or patent but published on or after the international filing date

"L" document which may throw doubts on priority claim(s) or which is cited to establish the publication date of another citation or other special reason (as specified)

"O" document referring to an oral disclosure, use, exhibition or other means

"P" document published prior to the international filing date but later than the priority date claimed

"T" later document published after the international filing date or priority date and not in conflict with the application but cited to understand the principle or theory underlying the invention

"X" document of particular relevance; the claimed invention cannot be considered novel or cannot be considered to involve an inventive step when the document is taken alone

"Y" document of particular relevance; the claimed invention cannot be considered to involve an inventive step when the document is combined with one or more other such documents, such combination being obvious to a person skilled in the art

"&" document member of the same patent family

Date of the actual completion of the international search

11 June 2015 (11.06.2015)

Date of mailing of the international search report

12 June 2015 (12.06.2015)

Name and mailing address of the ISA/KR

International Application Division
Korean Intellectual Property Office
189 Cheongsa-ro, Seo-gu, Daejeon Metropolitan City, 302-701,
Republic of Korea

Facsimile No. +82-42-472-7140

Authorized officer

Jung, Da Won

Telephone No. +82-42-481-8491

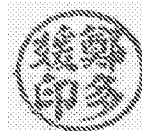

INTERNATIONAL SEARCH REPORTInternational application No.
PCT/US2015/010688**Box No. II Observations where certain claims were found unsearchable (Continuation of item 2 of first sheet)**

This international search report has not been established in respect of certain claims under Article 17(2)(a) for the following reasons:

1. Claims Nos.:
because they relate to subject matter not required to be searched by this Authority, namely:

2. Claims Nos.:
because they relate to parts of the international application that do not comply with the prescribed requirements to such an extent that no meaningful international search can be carried out, specifically:

3. Claims Nos.:
because they are dependent claims and are not drafted in accordance with the second and third sentences of Rule 6.4(a).

Box No. III Observations where unity of invention is lacking (Continuation of item 3 of first sheet)

This International Searching Authority found multiple inventions in this international application, as follows:

See extra sheet.

1. As all required additional search fees were timely paid by the applicant, this international search report covers all searchable claims.
2. As all searchable claims could be searched without effort justifying an additional fees, this Authority did not invite payment of any additional fees.
3. As only some of the required additional search fees were timely paid by the applicant, this international search report covers only those claims for which fees were paid, specifically claims Nos.:

4. No required additional search fees were timely paid by the applicant. Consequently, this international search report is restricted to the invention first mentioned in the claims; it is covered by claims Nos.: 1-16

Remark on Protest

- The additional search fees were accompanied by the applicant's protest and, where applicable, the payment of a protest fee.
- The additional search fees were accompanied by the applicant's protest but the applicable protest fee was not paid within the time limit specified in the invitation.
- No protest accompanied the payment of additional search fees.

The present application does not meet the requirements of unity of invention.

Group 1: Claims 1-16

Inventions related to an oxidative coupling of methane(OCM) system comprising (a-i, ii) and (b-1, 2, 3) steps and further comprising subsystems or units to the system of Claim 1.

Group 2: Claims 17-26

Inventions related to an oxidative coupling of methane(OCM) system comprising (a-i, ii) and (b) steps, OCM subsystem and further comprising a non-OCM process to the system of Claim 17.

Group 3: Claims 27-39

Inventions related to a catalyst for hydrogenation of acetylene in an oxidative coupling of methane (OCM) process.

Group 4: Claims 40-48

Inventions related to a catalyst for converting carbon monoxide (CO) and/or carbon dioxide (CO₂) into methane (CH₄) in an oxidative coupling of methane (OCM) process.

Group 5: Claims 49-55

Inventions related to a method for preventing coke formation on a methanation catalyst in an oxidative coupling of methane (OCM) process.

Group 6: Claims 56-65

Inventions related to an oxidative coupling of methane (OCM) system for production of olefins and power, comprising (a) and (b) steps.

Group 7: Claims 66-77

Inventions related to a method for producing at least one C₂+ alkene and power, comprising (a), (b) and (c) steps.

Group 8: Claims 78-89

Inventions related to a method for producing hydrocarbon compounds including two or more carbon atoms (C₂+ compounds), the method comprising (a)-(e) steps.

Group 9: Claims 90-101

Inventions related to an oxidative coupling of methane (OCM) system for production of hydrocarbon compounds including two or more carbon atoms (C₂+ compounds) comprising (a)-(d) steps.

Group 10: Claims 102-103

Inventions related to a method for producing hydrocarbon compounds comprising (a)-(e) steps different from other methods.

Group 11: Claim 104

Inventions related to a method for producing hydrocarbon compounds comprising (a)-(c) steps.

Group 12: Claim 105

Inventions related to a method for producing hydrocarbon compounds comprising (a)-(e) steps different from other methods.

Group 13: Claim 106

Inventions related to a method for producing hydrocarbon compounds comprising (a)-(d) steps.

Group 14: Claim 107

Inventions related to a method for producing hydrocarbon compounds comprising (a)-(e) steps different from other methods.

Group 15: Claim 108

Inventions related to a method for producing hydrocarbon compounds comprising (a)-(f) steps.

Continued on Next Page

Group 16: Claims 109-111

Inventions related to a method for producing hydrocarbon compounds comprising (a)-(f) steps different from other methods.

Group 17: Claims 112-114

Inventions related to a method for producing hydrocarbon compounds comprising (a)-(f) steps different from other methods.

Group 18: Claim 115

Inventions related to a method for producing hydrocarbon compounds including two or more carbon atoms comprising (a)-(g) steps.

Group 19: Claims 116-119

Inventions related to methods for producing hydrocarbon compounds comprising (a)-(d) steps different from other methods.

Group 20: Claims 120-123

Inventions related to methods for producing hydrocarbon compounds comprising (a)-(d) steps different from other methods.

INTERNATIONAL SEARCH REPORT

Information on patent family members

International application No.

PCT/US2015/010688

Patent document cited in search report	Publication date	Patent family member(s)	Publication date
US 2013-0225884 A1	29/08/2013	AU 2013-207783 A1 CA 2860773 A1 WO 2013-106771 A2 WO 2013-106771 A3	07/08/2014 18/07/2013 18/07/2013 08/05/2014
US 6518476 B1	11/02/2003	AR 033572 A1 AU 2001-292666 B2 AU 9266601 A BR 0114133 A BR 0114133 B1 CA 2421816 A1 CA 2421816 C CN 1458915 A CN 1458915 C EP 1322581 A1 JP 2004-509155 A KR 10-0571305 B1 KR 10-2003-0034191 A MX PA03002441 A MY 117933 A NO 20031209 A NO 20031209 D0 WO 02-24614 A1	26/12/2003 21/07/2005 02/04/2002 29/07/2003 04/09/2012 28/03/2002 17/11/2009 26/11/2003 22/08/2007 02/07/2003 25/03/2004 17/04/2006 01/05/2003 24/05/2004 30/08/2004 13/05/2003 17/03/2003 28/03/2002
WO 2011-008464 A1	20/01/2011	AU 2010-273876 A1 CN 102471181 A EA 201270073 A1 EP 2448888 A1 EP 2448888 A4 JP 2012-532104 A KR 10-2012-0109998 A TW 201119979 A US 2010-0331595 A1 US 8912381 B2	20/01/2011 23/05/2012 30/05/2012 09/05/2012 27/11/2013 13/12/2012 09/10/2012 16/06/2011 30/12/2010 16/12/2014
US 05430219 A	04/07/1995	CA 2107492 A1 DE 4333372 A1 IT 1255710 B RU 2100334 C1	02/04/1994 07/04/1994 10/11/1995 27/12/1997