



- (51) International Patent Classification:  
*H02H 7/26* (2006.01)
- (21) International Application Number:  
PCT/EP2011/055184
- (22) International Filing Date:  
4 April 2011 (04.04.2011)
- (25) Filing Language: English
- (26) Publication Language: English
- (71) Applicant (for all designated States except US): **ABB TECHNOLOGY AG** [CH/CH]; Affolternstrasse 44, CH-8050 Zurich (CH).
- (72) Inventors; and
- (75) Inventors/Applicants (for US only): **BERGGREN, Bertil** [SE/SE]; Sidengatan 4, S-724 76 Västerås (SE). **PAN, Juiping** [US/US]; 5401 south southern cross avenue, Raleigh, NC 27606 (US).
- (74) Agent: **AHRENGART, Kenneth**; ABB AB, Intellectual Property, Ingenjör Bååths Gata 11, T2, Floor E, S-721 83 Västerås (SE).

- (81) Designated States (unless otherwise indicated, for every kind of national protection available): AE, AG, AL, AM, AO, AT, AU, AZ, BA, BB, BG, BH, BR, BW, BY, BZ, CA, CH, CL, CN, CO, CR, CU, CZ, DE, DK, DM, DO, DZ, EC, EE, EG, ES, FI, GB, GD, GE, GH, GM, GT, HN, HR, HU, ID, IL, IN, IS, JP, KE, KG, KM, KN, KP, KR, KZ, LA, LC, LK, LR, LS, LT, LU, LY, MA, MD, ME, MG, MK, MN, MW, MX, MY, MZ, NA, NG, NI, NO, NZ, OM, PE, PG, PH, PL, PT, RO, RS, RU, SC, SD, SE, SG, SK, SL, SM, ST, SV, SY, TH, TJ, TM, TN, TR, TT, TZ, UA, UG, US, UZ, VC, VN, ZA, ZM, ZW.
- (84) Designated States (unless otherwise indicated, for every kind of regional protection available): ARIPO (BW, GH, GM, KE, LR, LS, MW, MZ, NA, SD, SL, SZ, TZ, UG, ZM, ZW), Eurasian (AM, AZ, BY, KG, KZ, MD, RU, TJ, TM), European (AL, AT, BE, BG, CH, CY, CZ, DE, DK, EE, ES, FI, FR, GB, GR, HR, HU, IE, IS, IT, LT, LU, LV, MC, MK, MT, NL, NO, PL, PT, RO, RS, SE, SI, SK, SM, TR), OAPI (BF, BJ, CF, CG, CI, CM, GA, GN, GQ, GW, ML, MR, NE, SN, TD, TG).

Published:  
— with international search report (Art. 21(3))

(54) Title: FAULT HANDLING DURING CIRCUIT BREAKER MAINTENANCE IN A DOUBLE-BREAKER BUSBAR SWITCHYARD

Fig. 2

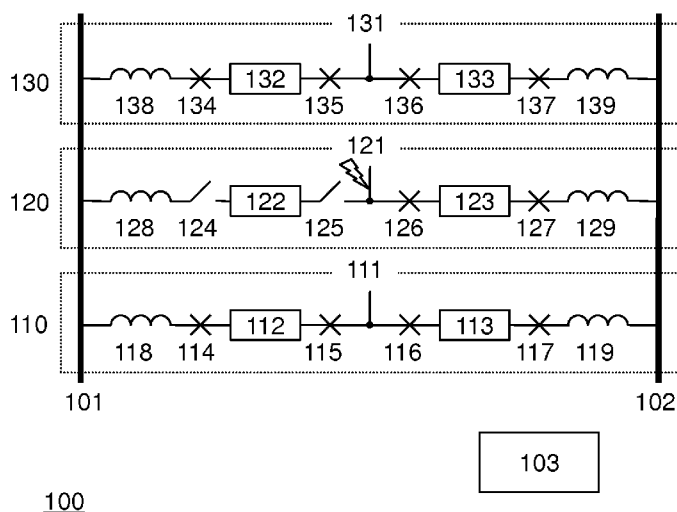

(57) Abstract: A fault protection device (103) for a high voltage direct current (HVDC) double-breaker busbar unit (100) is provided. The busbar unit (100) comprises a first busbar (101), a second busbar (102), and at least three switchgear bays (110, 120, 130), each switchgear bay comprising a pair of direct current (DC) circuit breakers (112, 113, 122, 123, 132, 133) being arranged for connecting a DC circuit (111, 121, 131) to the busbars (101, 2). The device is arranged for tripping, during maintenance of any of the circuit breakers (112, 122, 132) connected to the first busbar (101), in response to detecting a fault on a DC circuit (121) connected to the circuit breaker (122) under maintenance, all circuit breakers (113, 133) connected to the second busbar (102) except the circuit breaker (123) connected to the faulty DC circuit (121). An embodiment of the invention is advantageous in that the fault induced current which is to be interrupted is shared by at least two circuit breakers (113, 133). Further, a fault protection method of an HVDC double-breaker busbar unit is provided.

WO 2012/136241 A1

FAULT HANDLING DURING CIRCUIT BREAKER MAINTENANCE IN A  
DOUBLE-BREAKER BUSBAR SWITCHYARD

Field of the invention

The invention relates in general to high voltage direct current (HVDC)  
5 power transmission, and more specifically to fault handling during when a  
circuit breaker is open in a double-breaker busbar switchyard.

Background of the invention

10 HVDC power transmission is becoming increasingly important due to  
the steadily rising need for bulk power delivery and interconnected power  
transmission and distribution systems.

An HVDC grid typically comprises multiple terminals for converting an  
alternating current (AC) power source for transmission over transmission  
15 lines, i.e., underground cables and/or overhead lines, or vice versa. Within the  
grid, a terminal may be connected to multiple terminals resulting in different  
types of topologies. Such a multiple terminal grid enables efficient congestion  
management and has an improved stability against disturbances.

Within an HVDC grid, switchyards are employed for interconnecting  
20 transmission lines and converters, and for controlling the flow of electrical  
current through the grid. Typically, a switchyard comprises one or more  
busbars and several switchgear bays for connecting transmission lines, or  
converters, to the busbars. The switchgear bays are provided with DC circuit  
breakers which may be used for disconnecting a transmission line, or a  
25 converter. For instance, a transmission line, or a converter, may be  
disconnected in case of a fault on the transmission line, thereby preventing  
the fault from affecting other parts of the grid. Further, a transmission line, or  
a converter, may be disconnected for re-directing the flow of current through  
the grid.

In a double-breaker busbar switchyard, comprising two busbars, the current passing through a transmission line connected to the switchyard is shared by two DC circuit breakers connected between the transmission line and the busbars. This is advantageous since HVDC systems suffer, due to their low inductance, from a high rate of rise of fault induced currents. By sharing the current between two circuit breakers, the requirements on the circuit breakers, in particular with respect to their current interrupting capabilities, are lowered. However, in the event of a fault on a transmission line when one of the circuit breakers connected to that transmission line already is open, e.g. disconnected due to maintenance, the other circuit breaker has to break the whole fault-induced current by itself.

#### Summary of the invention

It is an object of the present invention to provide a more efficient alternative to the above techniques and prior art.

More specifically, it is an object of the present invention to provide an improved fault handling when a circuit breaker is already open in an HVDC double-breaker busbar switchyard.

These and other objects of the present invention are achieved by means of a fault protection device having the features defined in independent claim 1, and by means of a fault protection method defined in independent claim 10. Embodiments of the invention are characterized by the dependent claims.

According to a first aspect of the invention, a fault protection device for an HVDC double-breaker busbar unit is provided. The double-breaker busbar unit comprises a first busbar, a second busbar, and at least three pairs of DC circuit breakers. One of the circuit breakers of each pair is arranged for connecting a DC circuit to the first busbar. The other circuit breaker of each pair is arranged for connecting the DC circuit to the second busbar. The fault protection device is arranged for tripping, when any of the circuit breakers connected to the first busbar is already open, in response to detecting a fault on a DC circuit connected to the already open circuit breaker, all circuit

breakers connected to the second busbar except the circuit breaker connected to the DC circuit on which the fault is detected.

According to a second aspect of the invention, a fault protection method of an HVDC double-breaker busbar unit is provided. The double-breaker busbar unit comprises a first busbar, a second busbar, and at least three pairs of DC circuit breakers. One of the circuit breakers of each pair is arranged for connecting a DC circuit to the first busbar. The other circuit breaker of each pair is arranged for connecting the DC circuit to the second busbar. The method comprises tripping, when any of the circuit breakers connected to the first busbar is already open, in response to detecting a fault on a DC circuit connected to the already open circuit breaker, all circuit breakers connected to the second busbar except the circuit breaker connected to the DC circuit on which the fault is detected.

The present invention makes use of an understanding that the current which has to be interrupted by a circuit breaker in the event of a fault on a DC circuit, such as a DC transmission line, connected to a double-breaker busbar unit, may be limited if a special fault protection scheme is utilized when a circuit breaker is open. The special fault protection scheme is applied if a fault occurs on a DC circuit connected to an open circuit breaker. In the context of the present application, an open circuit breaker is to be understood as also meaning a circuit breaker which is disconnected, or isolated, from the busbar and the faulty DC circuit, respectively, e.g. due to maintenance or for some other reason. To this end, instead of tripping, i.e., opening, the circuit breaker belonging to the same pair of circuit breakers as the open circuit breaker, all other circuit breakers which are connected to the other busbar than the open circuit breaker, except the circuit breaker which is connected to the faulty DC circuit, are tripped. This is advantageous since the current which has to be interrupted is shared by at least two circuit breakers. Accordingly, if the busbar unit is arranged for being connected to more than three DC circuits, and, consequently, comprises more than tree circuit breaker pairs, the current is shared by more than two circuit breakers. Utilizing more than one circuit breaker for interrupting the current is advantageous since the requirements

on the circuit breakers, in particular, their current interrupting capabilities, are lowered, resulting in a simplified design and reduced costs.

According to an embodiment of the invention, the fault protection device is further arranged for detecting a fault on the DC circuit connected to the open circuit breaker. A fault protection device capable of detecting faults on the connected DC circuits, e.g., transmission lines, in addition to having fault handling capabilities, i.e., tripping of the circuit breakers comprised in the busbar unit, is advantageous in that fault detection and fault protection tasks may be integrated into a single device. Such a device is preferably arranged at a busbar unit, e.g., a switchyard. Techniques for detecting faults on DC circuits, in particular HVDC transmission lines, are well known in the art. For instance, the current flowing through a DC circuit may be monitored and compared to a threshold value. A measured current derivative and/or voltage derivative exceeding the threshold value is indicative of a fault on the DC circuit, such as a pole-to ground fault on a transmission line. Further, the direction of current flowing through a transmission line may be monitored at either end of the transmission line. In the event of a pole-to ground fault, current is fed into the transmission line from both ends. Alternatively, the fault protection device may be arranged for receiving fault-indicating signals, trip signals, or any information pertaining to faults, from an external control or protection device of an HVDC system to which the busbar unit, or switchyards, belongs.

According to an embodiment of the invention, the fault protection device is further arranged for activating, during maintenance of any of the circuit breakers, a maintenance mode for a DC circuit connected to the circuit breaker under maintenance. Such maintenance mode can also be activated when the circuit breaker is open for some other reason. To this end, the fault protection device is arranged for implementing the special fault protection scheme described hereinbefore when the maintenance mode is activated. In other words, the fault protection device is arranged for performing, in response to detecting a fault on a DC circuit or, alternatively, receiving a fault indication signal, certain protective measures, such as tripping circuit breakers, in accordance with the special fault protection scheme. The fault

protection device may further be arranged for toggling between a normal-operation mode and the maintenance mode. When in normal-operation mode, the fault protection device is arranged for implementing a fault protection scheme suitable for normal operation of the busbar unit, i.e., when all circuit breakers of the busbar unit are in operation. Such a fault protection scheme is well known in the art. For instance, in the event of a fault in a DC circuit connected to the double-breaker busbar unit, the two DC circuit breakers connecting the DC circuit to the two busbars may be tripped, thereby isolating the faulty DC circuit from the busbar unit. Depending on the operation mode of the busbar unit, i.e., normal-operation mode or maintenance mode, the fault protection device may be arranged for toggling, i.e., switching, between the two modes. This may, e.g., be achieved by activating either of two circuitries, a first circuitry being arranged for implementing the normal-operation mode and a second circuitry being arranged for implementing the maintenance mode, respectively. Alternatively, if the fault protection device is based on a microprocessor, a suitable software comprising instructions for implementing the desired mode may be executed.

According to an embodiment of the invention, the fault protection device is further arranged for, after the fault on the DC circuit connected to the open circuit breaker has been cleared, tripping the circuit breaker connected between the second busbar and the DC circuit on which the fault is detected, and re-closing all circuit breakers connected to the second busbar, except the circuit breaker connected between the second busbar and the DC circuit on which the fault is detected. In other words, after the fault current has been interrupted by means of all other circuit breakers but the circuit breaker belonging to the same pair as the already open circuit breaker, which circuit breakers are connected to the other busbar than the already open circuit breaker, the circuit breaker belonging to the same pair as the already open circuit breaker is opened and all other circuit breakers (except the one that was already open) are closed again. Such a switching operation may be accomplished within a few minutes, and the busbar unit is ready for the next fault.

According to an embodiment of the invention, an HVDC double-breaker busbar unit is provided. The busbar unit comprises a first busbar, a second busbar, at least three pairs of DC circuit breakers, and a fault protection device. One of the circuit breakers of each pair is arranged for connecting a DC circuit to the first busbar. The other circuit breaker of each pair is arranged for connecting the DC circuit to the second busbar. Providing a busbar unit with a fault protection device is advantageous in that means for fault handling are located at the busbar unit, thereby eliminating the need for communicating signals from an external fault protection unit to the circuit breakers comprised in the busbar unit.

According to an embodiment of the invention, each DC circuit is a DC transmission line, a converter, or a further double-breaker busbar unit. In general, any HVDC component being arranged for feeding current to, or extracting current from, the busbar unit may be connected to the busbar unit. To this end, a DC circuit may, e.g., be a DC transmission line, an AC-DC converter, a DC-DC converter, or another section of a double-breaker busbar switchyard.

According to an embodiment of the invention, each circuit breaker comprises means for isolating a circuit breaker. The circuit breakers may be isolated, i.e., disconnected from their respective DC circuit and their respective busbar, by means of disconnecting switches connected in series with the circuit breaker, one switch on either side of the circuit breaker. This is advantageous in that a circuit breaker may easily be taken out of service for maintenance. Further, the disconnecting switches may optionally be utilized for disconnecting the faulty DC circuit after the fault current has been interrupted.

According to an embodiment of the invention, an HVDC switchyard is provided. The switchyard comprises an HVDC double-breaker busbar unit.

It will be appreciated that the special fault protection scheme described hereinabove may be applied to double-breaker busbar units comprising a circuit breaker which is unavailable for interrupting a fault current because the circuit breaker is already open, because the circuit breaker is under

maintenance, or simply because the circuit breaker has been disconnected by means of disconnecting switches.

Further objectives of, features of, and advantages with, the present invention will become apparent when studying the following detailed disclosure, the drawings and the appended claims. Those skilled in the art realize that different features of the present invention can be combined to create embodiments other than those described in the following.

#### Brief description of the drawings

10

The above, as well as additional objects, features and advantages of the present invention, will be better understood through the following illustrative and non-limiting detailed description of embodiments of the present invention, with reference to the appended drawings, in which:

15 Fig. 1 shows a double-breaker busbar switchyard according to an embodiment of the invention.

Fig. 2 illustrates fault handling in the event of an already open circuit breaker.

20 Fig. 3 shows a double-breaker busbar switchyard according to another embodiment of the invention.

All the figures are schematic, not necessarily to scale, and generally only show parts which are necessary in order to elucidate the invention, wherein other parts may be omitted or merely suggested.

#### 25 Detailed description

In Fig. 1, a double-breaker busbar switchyard according to an embodiment of the invention is illustrated. Switchyard 100 comprises two busbars 101 and 102, and three switchgear bays 110, 120, and 130. Each switchgear bay 110, 120, and 130, is arranged for connecting a DC circuit 111, 121, and 131, respectively, to busbars 101 and 102. For instance, switchgear 110 comprises two DC circuit breakers 112 and 113, which are connected between DC circuit 111 and busbars 101 and 102, respectively,

such that current may be fed to, or extracted from, the busbars via DC circuit 111.

Switchgear bay 110 further comprises disconnecting switches 114–117 for isolating circuit breakers 112 and 113, e.g. for maintenance. More specifically, disconnecting switches 114 and 115 are connected in series with circuit breaker 112, and disconnecting switches 116 and 117 are connected in series with circuit breaker 113. Switchgear bay 110 may further comprise inductances, i.e., station reactors, 118 and 119 for limiting the rate of rise of fault induced currents.

Switchgear bays 120 and 130 are similar to switchgear bay 110 described hereinabove. In particular, switchgear bay 120 is arranged for connecting DC circuit 121 to busbars 101 and 102, via circuit breakers 122 and 123, respectively, and switchgear bay 130 is arranged for connecting DC circuit 131 to busbars 101 and 102, via circuit breakers 132 and 133, respectively. Switchgear bays 120 and 130 further comprise disconnecting switches 124–127 and 134–137, respectively, as well as inductances 128, 129, 138, and 139. For the purpose of describing the present invention, DC circuit 111 may, e.g., be an AC-DC converter, and DC circuits 121 and 131 may be DC transmission lines.

Switchyard 100 further comprises a fault protection device 103 which is arranged for fault detection and fault protection, i.e., fault handling. For this purpose, means for detecting faults on DC circuits 111, 121, and 131, are provided, which means are in communication with fault protection device 103 (not shown in Fig. 1). Further, fault protection device 103 is arranged for sending trip signals to circuit breakers 112, 113, 122, 123, 132, and 133, in response to detecting a fault on any of the DC circuits 111, 121, and 131. The fault handling performed by fault protection device 103, i.e., which circuit breakers are tripped in the event of a fault on any of the DC circuits, follows a fault handling scheme implemented in fault protection device 103.

With reference to Fig. 2, a known fault handling scheme, which may be utilized when a circuit breaker comprised in a double-breaker busbar unit is already open, or disconnected due to maintenance, is illustrated by way of switchyard 100, described with reference to Fig. 1. Such a fault handling

scheme may, e.g., be implemented as an alternative to the inventive fault handling scheme, i.e., a fault protection method according to an embodiment of the invention, in fault protection device 103. In order to not obscure the drawing, reference numerals which are not needed for elucidating the known fault handling scheme have been omitted from Fig. 2.

In Fig. 2, circuit breaker 122 has been isolated, by means of disconnecting switches 124 and 125, for maintenance. Thus, the current through transmission line 121 is carried by circuit breaker 123 alone. In the event of a fault on transmission line 121, as indicated by the lightning symbol in Fig. 2, circuit breaker 123 will be tripped. In order to guarantee that circuit breaker 123 is capable of interrupting the current, and in light of the high rate of rise of fault induced currents in HVDC transmission systems, circuit breaker 123 has to be dimensioned with a current interrupting capability sufficiently high for breaking the current by itself. This is in contrast to the basic concept of the double-breaker busbar arrangement, namely that, in the event of a fault occurring on a DC circuit, e.g., DC circuit 111, connected to a switchgear with both circuit breakers in service, a fault induced current is interrupted jointly by both circuit breakers 112 and 113. Thus, applying a known fault handling scheme requires to take the full fault induced current into account when dimensioning the circuit breakers of switchyard 100, resulting in an increased complexity of the circuit breakers.

Further with reference to Fig. 2, a fault handling scheme according to an embodiment of the invention is described, still assuming that circuit breaker 122 is disconnected for maintenance (or simply already open for whatever reason). The fault handling according to an embodiment of the invention differs from the known fault handling scheme in that, in the event of a fault on transmission line 121, circuit breakers 113 and 133 are tripped instead of circuit breaker 123. In that way, the fault induced current is shared by two circuit breakers. This is advantageous since the requirements with respect to the current interrupting capabilities of the circuit breakers comprised in switchyard 100 are reduced, resulting in a less complex circuit breaker design and, correspondingly, reduced costs.

More specifically, according to the invention, for a switchyard comprising three switchgear bays, such as switchyard 100 described with reference to Fig. 2, each circuit breaker needs only to have a current breaking capability which is equal to half of the total fault current, preferably with some safety margin. The total fault current may be determined by a system fault current analysis assuming worst-case scenario.

Fault protection device 103 may further be arranged for tripping, after the fault on DC circuit 121 has been cleared, i.e., after the fault current has been interrupted by circuit breakers 113 and 133, circuit breaker 123 and, subsequently, re-closing circuit breakers 113 and 133. After this switching operation has been completed, which may be accomplished within a few minutes, DC circuits 111 and 131 are back in service.

Even though switchyard 100 has been illustrated as comprising three switchgear bays only, one may easily envisage embodiments of the invention comprising more than three switchgear bays. In general, in a switchyard comprising  $n$  switchgear bays, where  $n$  is larger than or equal to three, the current which is induced by a fault on a DC circuit connected to a switchgear bay comprising a circuit breaker which is disconnected for maintenance, is shared by  $n-1$  circuit breakers if fault handling according to an embodiment of the invention is performed.

One may easily envisage embodiments of the invention being arranged for protecting a double-breaker busbar unit comprising a circuit breaker which is unavailable for interrupting a fault current for reasons other than maintenance. For instance, circuit breaker 122 of switchyard 100 may already be open because of a circuit breaker failure, or it may be disconnected due to a fault in any of the disconnectors 124 and 125 associated with circuit breaker 122. For this purpose, fault protection device 103 may further be arranged for sensing the state, e.g., open or closed, of circuit breakers 112, 113, 122, 123, 132, 133 and disconnectors 114–117, 124–127, 134–137. In the event of an open circuit breaker or disconnector, such as circuit breaker 122 or disconnector 125, the special fault protection scheme is applied to the DC circuit to which the open circuit breaker, or disconnector, is connected, in this case DC circuit 121.

With reference to Fig. 3, a further embodiment of the invention is described. Switchyard 300 comprises two double-breaker busbar sections 310 and 320, interconnected by means of circuit breakers 301 and 302. Busbar sections 310 and 320 may, e.g., be similar to switchyard 100 described with reference to Fig. 1. For the sake of clarity, only two and one switchgear bays are shown for busbar sections 310 and 320, respectively. However, busbar sections 310 and 320 may comprise any number of switchgear bays suitable for the application at hand. Switchyard 300 further comprises a fault protection device 303 which is arranged for detecting faults on DC circuits, i.e., transmission lines or converters, connected to busbar sections 310 and 320, respectively, and for performing fault handling in accordance with an embodiment of the invention. Dividing a switchyard comprising a considerable number of switchgear bays into several busbar sections, which busbar sections are interconnected by means of circuit breakers, is advantageous in that a busbar section in which a fault is detected, or which is under maintenance, may be isolated from the switchyard by opening the circuit breakers interconnecting that busbar section with adjacent busbar sections and connected DC circuits. With reference to Fig. 3, in the event of a fault on a transmission line connected to a switchgear bay of busbar section 310, which switchgear bay comprises a circuit breaker under maintenance, fault protection device 303 may trip the circuit breakers comprised in busbar section 310, as was described with reference to the fault handling scheme according to an embodiment of the invention, in addition to circuit breaker 301, if the circuit breaker under maintenance is connected to the left side busbar, or circuit breaker 302, if the circuit breaker under maintenance is connected to the right side busbar, thereby interrupting the fault induced current contributions from busbar section 320. In this respect, busbar section 320 may be considered as a DC circuit connected to busbar section 310. Thus, a double-breaker busbar unit according to an embodiment of the invention, comprising at least three switchgear bays, may be connected to at least two transmission lines, converters, or any other types of DC circuits, in addition to being connected, via the third switchgear bay, to another double-breaker busbar section.

With respect to circuit breaker ratings, circuit breakers 301 and 302, interconnecting busbar sections 310 and 320, may have current breaking capabilities different from the circuit breakers comprised in the switchgear bays. In particular the circuit breakers comprised in the switchgear bays may  
5 have lower current breaking capabilities than the circuit breakers interconnecting busbar sections, and their specific needed current breaking capabilities will depend on the number of switchgear bays in each busbar section.

According to an embodiment of the invention, the fault protection  
10 device is further arranged for activating, during maintenance of any of the circuit breakers, a maintenance mode for a DC circuit connected to the circuit breaker under maintenance. To this end, the fault protection device is arranged for implementing the special fault protection scheme described  
15 hereinbefore when the maintenance mode is activated. In other words, the fault protection device is arranged for performing, in response to detecting a fault on a DC circuit or, alternatively, receiving a fault indication signal, certain protective measures, such as tripping circuit breakers, in accordance with the special fault protection scheme. The fault protection device may further be arranged for toggling between a normal-operation mode and the maintenance  
20 mode. When in normal-operation mode, the fault protection device is arranged for implementing a fault protection scheme suitable for normal operation of the busbar unit, i.e., when all circuit breakers of the busbar unit are in operation. Such a fault protection scheme is well known in the art. For instance, in the event of a fault in a DC circuit connected to the double-  
25 breaker busbar unit, the two DC circuit breakers connecting the DC circuit to the two busbars may be tripped, thereby isolating the faulty DC circuit from the busbar unit. Depending on the operation mode of the busbar unit, i.e., normal-operation mode or maintenance mode, the fault protection device may be arranged for toggling, i.e., switching, between the two modes. This may,  
30 e.g., be achieved by activating either of two circuitries, a first circuitry being arranged for implementing the normal-operation mode and a second circuitry being arranged for implementing the maintenance mode, respectively. Alternatively, if the fault protection device is based on a microprocessor, a

suitable software comprising instructions for implementing the desired mode may be executed.

Embodiments of the fault protection device, such fault protection device 103 described with reference to Figs. 1 and 2, or fault protection device 303 described with reference to Fig. 3, may be based on processing means executing a suitable software, on electronic circuits, or a combination of both. One may also envisage embodiments of the invention which are based on a readily available computer, or an existing control unit or failure protection unit of an HVDC system, executing software which implements the method according to the second aspect of the invention.

The person skilled in the art realizes that the present invention by no means is limited to the embodiments described above. On the contrary, many modifications and variations are possible within the scope of the appended claims. For example, even though the fault protection device has been described as being arranged at a switchyard, one may envisage embodiments of the fault protection device arranged at any HVDC unit, e.g., a central control or protection unit of an HVDC system. It will also be appreciated that embodiments of the invention may be implemented as software which is suitable for upgrading an existing failure protection unit.

In conclusion, a fault protection device for an HVDC double-breaker busbar unit is provided. The busbar unit comprises a first busbar, a second busbar, and at least three switchgear bays, each bay comprising a pair of DC circuit breakers being arranged for connecting a DC circuit to the busbars. The device is arranged for tripping, during maintenance of any of the circuit breakers connected to the first busbar, in response to detecting a fault on a DC circuit connected to the circuit breaker under maintenance, all circuit breakers connected to the second busbar except the circuit breaker connected to the faulty DC circuit. An embodiment of the invention is advantageous in that the fault induced current which is to be interrupted is shared by at least two circuit breakers. Further, a fault protection method of an HVDC double-breaker busbar unit is provided.

## CLAIMS

1. A fault protection device (103; 303) for a high voltage direct current, HVDC, double-breaker busbar unit (100; 310, 320) comprising:
- 5 a first (101) and a second busbar (102),  
at least three pairs of direct current, DC, circuit breakers (112, 113, 122, 123, 132, 133), one of the circuit breakers (112, 122, 132) of each pair being arranged for connecting a DC circuit (111, 121, 131) to the first busbar (101), and the other circuit breaker (113, 123, 133) of each pair being
- 10 arranged for connecting the DC circuit to the second busbar (102),  
wherein the fault protection device (103; 303) is arranged for:
- tripping, when any of the circuit breakers (112, 122, 132) connected to the first busbar (101) is already open, and in response to detecting a fault on a DC circuit (121) connected to the already open circuit breaker (122) , all
- 15 circuit breakers (113, 133) connected to the second busbar (102) except the circuit breaker (123) connected to the DC circuit (121) on which the fault is detected.
2. The fault protection device (103; 303) according to claim 1, being
- 20 further arranged for detecting a fault on the DC circuit (121) connected to the already open circuit breaker (122) .
3. The fault protection device (103; 303) according to claim 1, being further arranged for activating, when any of the circuit breakers (112, 113,
- 25 122, 123, 132, 133) is already open, a maintenance mode for a DC circuit (121) connected to the already open circuit breaker (122).
4. The fault protection device (103; 303) according to claim 1, being further arranged for, after the fault on the DC circuit (121) connected to the
- 30 already open circuit breaker (122) has been cleared:
- tripping the circuit breaker (123) connected between the second busbar (102) and the DC circuit (121) on which the fault is detected, and

re-closing all circuit breakers (113, 133) connected to the second busbar (102), except the circuit breaker (123) connected between the second busbar (102) and the DC circuit (121) on which the fault is detected.

5           5. The fault protection device (103; 303) according to any one of claims 1-4, wherein the already open circuit breaker is a circuit breaker disconnected due to maintenance of the circuit breaker.

10           6. A high voltage direct current, HVDC, double-breaker busbar unit (100; 310, 320) comprising:  
            a first (101) and a second busbar (102),  
            at least three pairs of direct current, DC, circuit breakers (112, 113, 122, 123, 132, 133), one of the circuit breakers (112, 122, 132) of each pair being arranged for connecting a DC circuit (111, 121, 131) to the first  
15 busbar (101), and the other circuit breaker (113, 123, 133) of each pair being arranged for connecting the DC circuit (111, 121, 131) to the second busbar (102), and  
            a fault protection device (103; 303) according to any one of the claims 1-5.

20

            7. The busbar unit (100; 310, 320) according to claim 6, wherein each DC circuit (111, 121, 131) is a DC transmission line, a converter, or a further double-breaker busbar unit (100; 320, 310).

25           8. The busbar unit (100; 310, 320) according to claim 6, wherein each circuit breaker (112, 113, 122, 123, 132, 133) comprises means (114-117, 124-127, 134-137) for isolating the already open circuit breaker.

            9. A high voltage direct current, HVDC, switchyard (100; 300)  
30 comprising an HVDC double-breaker busbar unit (100; 310, 320) according to any one of the claims 6-8.

10. A fault protection method of a high voltage direct current, HVDC, double-breaker busbar unit (100; 310, 320), said unit comprising:  
a first (101) and a second busbar (102),  
at least three pairs of direct current, DC, circuit breakers (112, 113,  
5 122, 123, 132, 133), one of the circuit breakers (112, 122, 132) of each pair being arranged for connecting a DC circuit (111, 121, 131) to the first busbar (101), and the other circuit breaker (113, 123, 133) of each pair being arranged for connecting the DC circuit (111, 121, 131) to the second busbar (102),  
10 the method comprising:  
tripping, when any of the circuit breakers (112, 113, 122, 123, 132, 133) connected to the first busbar (101) is already open, and in response to detecting a fault on a DC circuit (121) connected to the already open circuit breaker (122), all circuit breakers (113, 133) connected to the second  
15 busbar (102) except the circuit breaker (123) connected to the DC circuit (121) on which the fault is detected.
11. The method according to claim 10, further comprising:  
detecting a fault on the DC circuit (121) connected to the already open circuit  
20 breaker (122).
12. The method according to claim 10, further comprising:  
activating, when any of the circuit breakers (112, 113, 122, 123, 132,  
133) is already open, a maintenance mode for a DC circuit (121) connected to  
25 the already open circuit breaker (122).
13. The method according to claim 10, further comprising, after the fault on the DC circuit (121) connected to the already open circuit breaker (122) has been cleared:  
30 tripping the circuit breaker (123) connected between the second busbar (102) and the DC circuit (121) on which the fault is detected, and

re-closing all circuit breakers (113, 133) connected to the second busbar (102), except the circuit breaker (123) connected between the second busbar (102) and the DC circuit (121) on which the fault is detected.

- 5           14. The fault protection method according to any one of claims 10-13, wherein the already open circuit breaker is a circuit breaker disconnected due to maintenance of the circuit breaker.

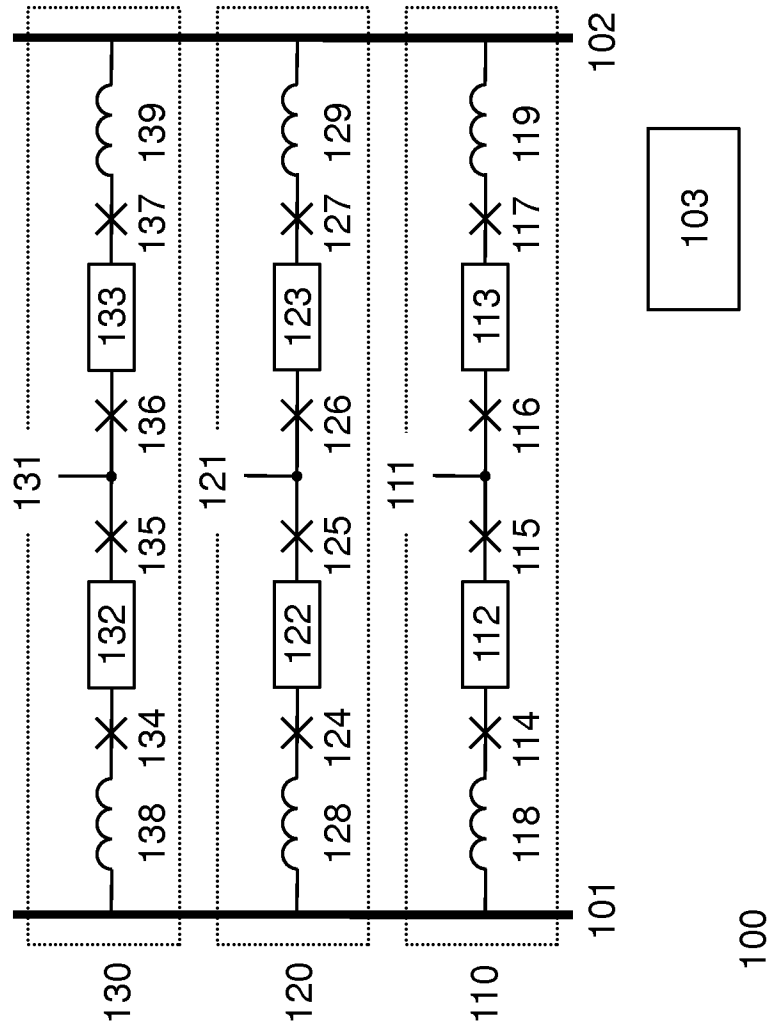

Fig. 1

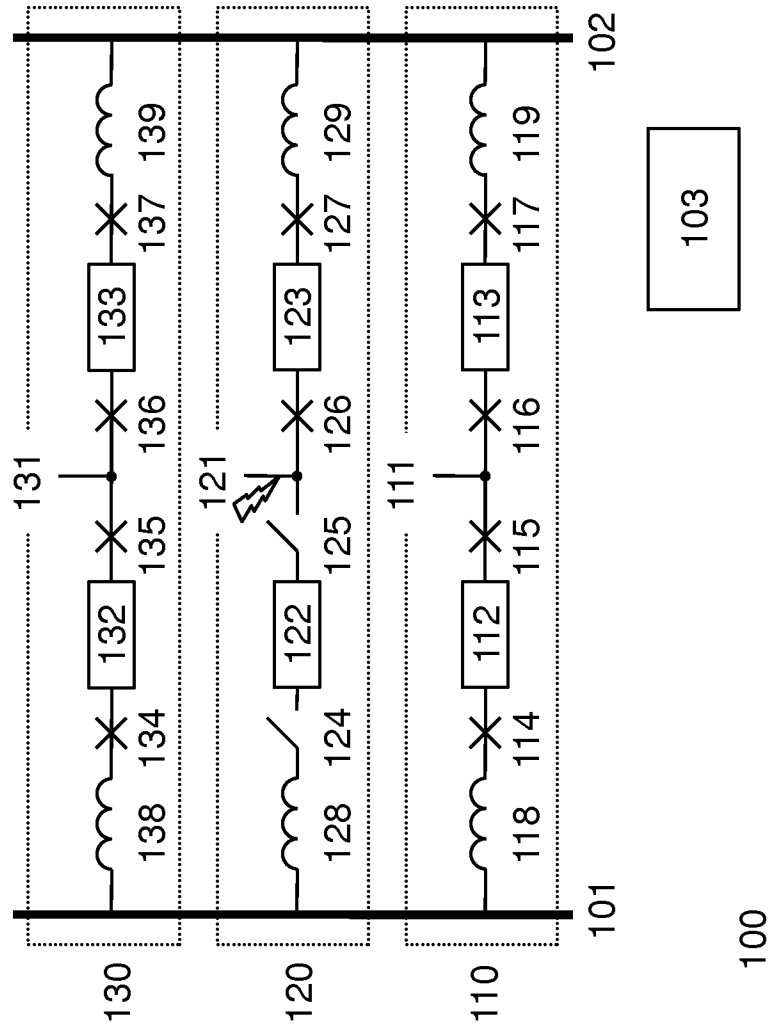

Fig. 2

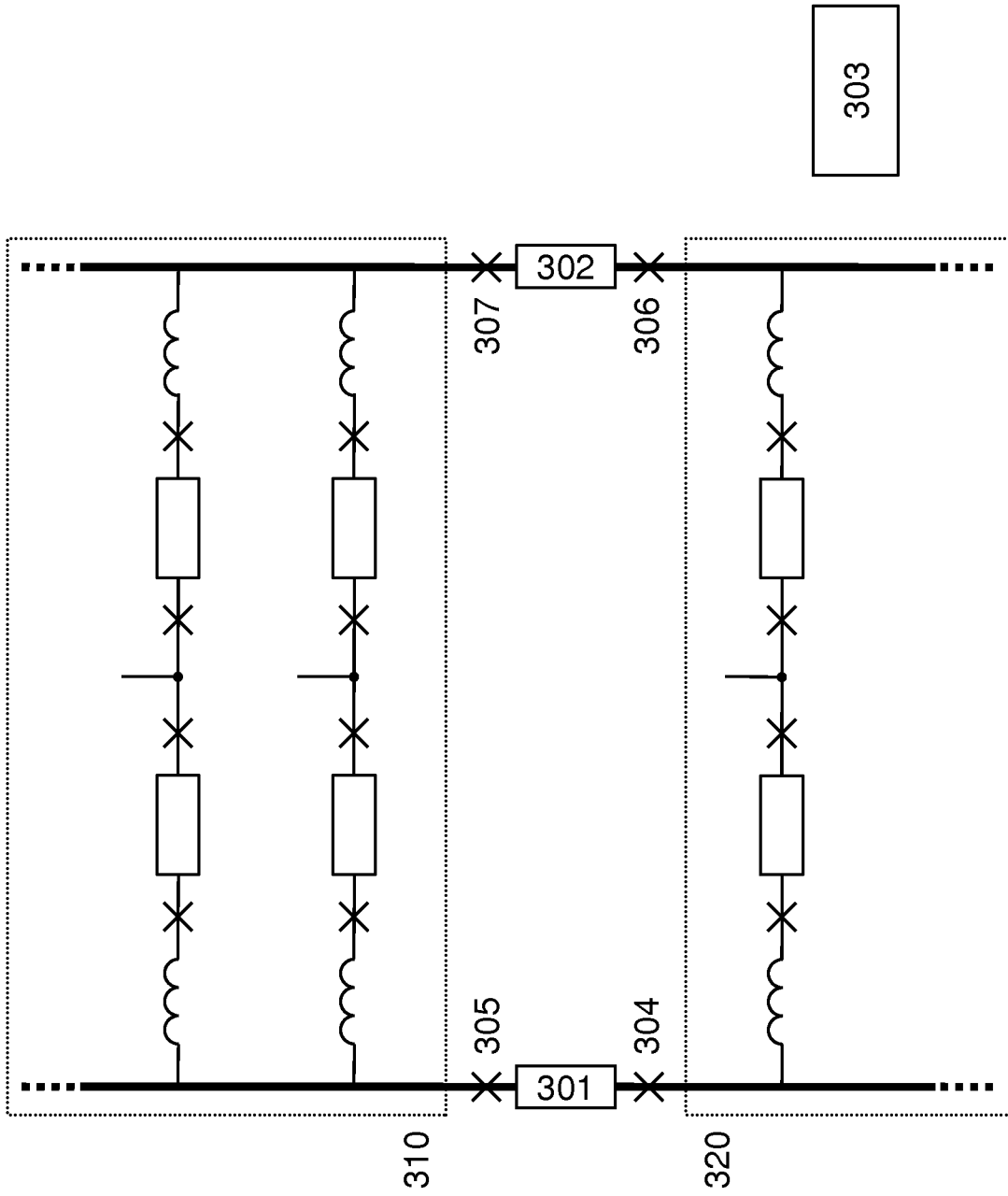

Fig. 3

INTERNATIONAL SEARCH REPORT

International application No  
PCT/EP2011/055184

A. CLASSIFICATION OF SUBJECT MATTER  
INV. H02H7/26  
ADD.  
According to International Patent Classification (IPC) or to both national classification and IPC

B. FIELDS SEARCHED  
Minimum documentation searched (classification system followed by classification symbols)  
H02H

Documentation searched other than minimum documentation to the extent that such documents are included in the fields searched

Electronic data base consulted during the international search (name of data base and, where practical, search terms used)  
EPO-Internal, WPI Data

C. DOCUMENTS CONSIDERED TO BE RELEVANT

Category*	Citation of document, with indication, where appropriate, of the relevant passages	Relevant to claim No.
A	WO 2007/084040 A1 (ABB TECHNOLOGY LTD [CH]; AASTROEM URBAN [SE]; RADBRANDT ULF [SE]) 26 July 2007 (2007-07-26) page 12, line 31 - page 16, line 4; figures 1-5	1-14
A	EP 1 914 162 A1 (CONVERTEAM LTD [GB] CONVERTEAM UK LTD [GB]) 23 April 2008 (2008-04-23) paragraph [0087] - paragraph [0098]; figure 2 abstract	1-14
A	US 6 008 971 A (DUBA GREG A [US] ET AL) 28 December 1999 (1999-12-28) claims 1-4,10-12 abstract	1-14

Further documents are listed in the continuation of Box C.

See patent family annex.

\* Special categories of cited documents :

- "A" document defining the general state of the art which is not considered to be of particular relevance
- "E" earlier document but published on or after the international filing date
- "L" document which may throw doubts on priority claim(s) or which is cited to establish the publication date of another citation or other special reason (as specified)
- "O" document referring to an oral disclosure, use, exhibition or other means
- "P" document published prior to the international filing date but later than the priority date claimed

- "T" later document published after the international filing date or priority date and not in conflict with the application but cited to understand the principle or theory underlying the invention
- "X" document of particular relevance; the claimed invention cannot be considered novel or cannot be considered to involve an inventive step when the document is taken alone
- "Y" document of particular relevance; the claimed invention cannot be considered to involve an inventive step when the document is combined with one or more other such documents, such combination being obvious to a person skilled in the art.
- "&" document member of the same patent family

Date of the actual completion of the international search  15 February 2012	Date of mailing of the international search report  23/02/2012
---	--

Name and mailing address of the ISA/ European Patent Office, P.B. 5818 Patentlaan 2 NL - 2280 HV Rijswijk Tel. (+31-70) 340-2040, Fax: (+31-70) 340-3016	Authorized officer  Lehnberg, Christian
--	---

# INTERNATIONAL SEARCH REPORT

Information on patent family members

International application No

PCT/EP2011/055184

Patent document cited in search report	Publication date	Patent family member(s)	Publication date	
WO 2007084040	A1	26-07-2007	BR PI0621005 A2	29-11-2011
			CN 101297449 A	29-10-2008
			EP 1974430 A1	01-10-2008
			US 2009316446 A1	24-12-2009
			WO 2007084040 A1	26-07-2007
			ZA 200805670 A	29-04-2009
-----				
EP 1914162	A1	23-04-2008	AT 470625 T	15-06-2010
			CA 2604992 A1	16-04-2008
			CN 101165988 A	23-04-2008
			DK 1914162 T3	27-09-2010
			EP 1914162 A1	23-04-2008
			ES 2347364 T3	28-10-2010
			GB 2443002 A	23-04-2008
			KR 20080034397 A	21-04-2008
			SG 142229 A1	28-05-2008
			US 2010284117 A1	11-11-2010
-----				
US 6008971	A	28-12-1999	DE 69904096 D1	09-01-2003
			DE 69904096 T2	10-04-2003
			EP 0948111 A2	06-10-1999
			JP 11313438 A	09-11-1999
			US 6008971 A	28-12-1999
-----				