



- (51) International Patent Classification: **G06F 1/32** (2006.01)
- (21) International Application Number: PCT/EP2011/056369
- (22) International Filing Date: 20 April 2011 (20.04.2011)
- (25) Filing Language: English
- (26) Publication Language: English
- (71) Applicant (for all designated States except US): **TELEFONAKTIEBOLAGET L M ERICSSON (PUBL)** [SE/SE]; S-164 83 Stockholm (SE).
- (72) Inventors; and
- (75) Inventors/Applicants (for US only): **MALMBERG, Jonas** [SE/SE]; Sävgatan 2, S-386 33 Färjestaden (SE). **BORGENGREN, Henrik** [SE/SE]; Laxrökargränd 10, S-393 64 Kalmar (SE). **KARLSSON, Magnus** [SE/SE]; Södravägen 46-B, Igh 1105, S-572 51 Oskarshamn (SE). **KULLMAN, Anders** [SE/SE]; Djurängsvägen 66-A, S-393 54 Kalmar (SE). **PERSSON, Oscar** [SE/SE]; Maleksvägen 30, S-394 71 Kalmar (SE). **WAHLEDOW, Fredrik** [SE/SE]; Morkullelegatan 12, S-386 30 Färjestaden (SE).
- (74) Agents: **SPROSTON, David** et al.; Hoffmann - Eitle, Arabellastrasse 4, 81925 Munich (DE).
- (81) Designated States (unless otherwise indicated, for every kind of national protection available): AE, AG, AL, AM, AO, AT, AU, AZ, BA, BB, BG, BH, BR, BW, BY, BZ, CA, CH, CL, CN, CO, CR, CU, CZ, DE, DK, DM, DO, DZ, EC, EE, EG, ES, FI, GB, GD, GE, GH, GM, GT, HN, HR, HU, ID, IL, IN, IS, JP, KE, KG, KM, KN, KP, KR, KZ, LA, LC, LK, LR, LS, LT, LU, LY, MA, MD, ME, MG, MK, MN, MW, MX, MY, MZ, NA, NG, NI, NO, NZ, OM, PE, PG, PH, PL, PT, RO, RS, RU, SC, SD, SE, SG, SK, SL, SM, ST, SV, SY, TH, TJ, TM, TN, TR, TT, TZ, UA, UG, US, UZ, VC, VN, ZA, ZM, ZW.
- (84) Designated States (unless otherwise indicated, for every kind of regional protection available): ARIPO (BW, GH, GM, KE, LR, LS, MW, MZ, NA, SD, SL, SZ, TZ, UG, ZM, ZW), Eurasian (AM, AZ, BY, KG, KZ, MD, RU, TJ, TM), European (AL, AT, BE, BG, CH, CY, CZ, DE, DK, EE, ES, FI, FR, GB, GR, HR, HU, IE, IS, IT, LT, LU, LV, MC, MK, MT, NL, NO, PL, PT, RO, RS, SE, SI, SK, SM, TR), OAPI (BF, BJ, CF, CG, CI, CM, GA, GN, GQ, GW, ML, MR, NE, SN, TD, TG).

[Continued on next page]

(54) Title: CONTROL OF DYNAMIC BUS VOLTAGE IN AN INTERMEDIATE BUS ARCHITECTURE POWER SYSTEM

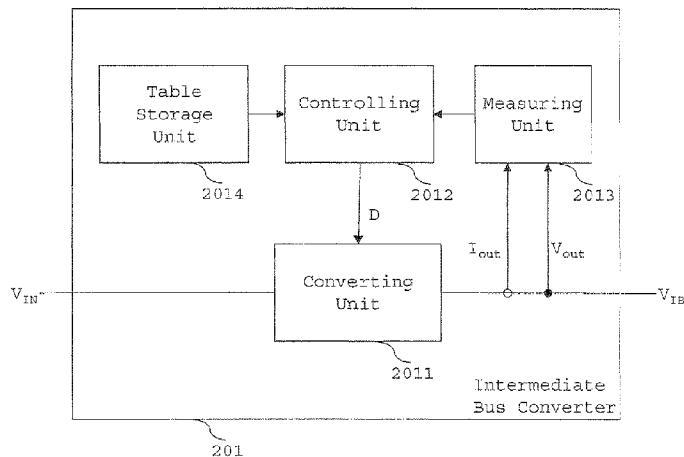

Fig. 3

(57) Abstract: To reduce power loss in an intermediate bus architecture power system, an intermediate bus converter is provided which converts an input voltage to an intermediate bus voltage using a converting unit; receives a signal indicative of an output of a converting unit; determines an intermediate bus voltage to reduce power loss in dependence upon the signal indicative of an output of the converting unit; generates a control signal to control the converting unit to convert the input voltage to the determined intermediate bus voltage; and generates an intermediate bus voltage in dependence upon the control signal.



Published:

- *without international search report and to be republished upon receipt of that report (Rule 48.2(g))*

Control of Dynamic Bus Voltage in an Intermediate Bus
Architecture Power System

5

[Technical Field]

The present invention relates to the field of Intermediate Bus
Architecture (IBA) power systems.

10

[Background]

Intermediate Bus Architecture (IBA) power systems are well known
systems for distributing power. An example Intermediate Bus
Architecture system 100 is illustrated in Figure 1. By way of
15 example, the system shown in Figure 1 is a pure DC system, and
accordingly no AC/DC converters are included in the system.

In such power systems the Intermediate Bus Converter (IBC) 101
delivers a pre-determined voltage to the Point of Load (POL)
regulators 102 - 104 connected to the loads (not shown).

20 The Intermediate Bus Converter 101 could be one of three general
types, namely fixed-ratio DC/DC converter (isolated or non-
isolated), line regulated DC/DC converter or fully regulated
DC/DC converter. The Intermediate Bus Converter receives an input
voltage V_{in} which is typically a DC voltage in one of the ranges
25 of 36-75 V, 18 - 36 V or 18 - 60 V.

The Intermediate Bus Converter outputs an Intermediate Bus
Voltage (V_{IB}) which is used as the input voltage to the Point of
Load regulators.

The Point of Load regulators supply the loads in the user system.
30 These Point of Loads are typically non-isolated. It is typical
that the Intermediate Bus Converter's and Point of Load
Regulators' topology can be any type, namely Buck, Boost, Buck-
Boost, etc. isolated or unisolated.

In such a system, the Intermediate Bus Voltage is normally fixed, but with the emerging market of digitally managed Intermediate Bus Converters and Point of Load Regulators there is now a possibility to adjust the Intermediate Bus Voltage to achieve greater efficiencies.

It is also possible to have current sharing between Intermediate Bus Converters and also between Point of Load Regulators. This is achieved using multiple Intermediate Bus Converters and multiple Point of Load Regulators. Information is traded between the different power converters (in the same stage) using Current Sharing Busses (CSBs). There is typically only one such bus in the Intermediate Bus Converter stage. However, in the Point of Load Regulator stage, there can be numerous busses. The Current Sharing Busses are not a part of the invention disclosed herein, but it should be noted that the invention is not conditioned by the presence of Current Sharing Busses.

In a traditional Intermediate Bus Architecture system, the Intermediate Bus Voltage is not regulated for an optimized system efficiency based on the actual load conditions. Instead, the Intermediate Bus Voltage remains fixed independently of the output load.

In order to enable to newer power systems to vary the Intermediate Bus Voltage, it is necessary to include a Board Power Manager (BPM) 110, as shown in Figure 1. The Board Power Manager accepts measurements from each of the Point of Load Regulators about their respective operating conditions e.g., output current and output voltage, and calculates based on these measurements, the appropriate Intermediate Bus Voltage. The Board Power Manager 110 then instructs the Intermediate Bus Converter, via a Power Management Bus, to either raise or lower its output voltage, and hence raise or lower the Intermediate Bus Voltage, for maximised efficiency.

However, this scheme suffers from a number of problems. For example, it is necessary to have a Board Power Manager that has been programmed with an algorithm that controls the output voltage by communication to the Intermediate Bus Converter. This Board Power Manager adds to the purchase cost of the system, and also adds to maintenance requirements of the system. In addition, the Board Power Manager 110 makes the system more complex since the Board Power Manager needs to collect data from the Point of Load Regulators before adjusting the output voltage from the Intermediate Bus Converter.

In view of the problems in known dynamic Intermediate Bus Voltage power systems, it would be desirable to provide an apparatus and method for controlling the Intermediate Bus Voltage so as to simplify maintenance and operation of the power system whilst still providing maximal power efficiency.

[Summary]

The present inventors have found that an Intermediate Bus Voltage to reduce power loss can be determined without collecting information from the Point of Load regulators, by utilising information available within the Intermediate Bus Converter. By exploiting this finding, the inventors have devised an apparatus and method for dynamically controlling the Intermediate Bus Voltage without requiring the use of a Board Power Manager.

According to the present invention there is provided an Intermediate Bus Converter operable to generate an Intermediate Bus Voltage for use in an intermediate bus architecture power system. The Intermediate Bus Converter comprises a converting unit and controlling unit. The converting unit is operable to receive an input voltage and a control signal and is operable to generate an Intermediate Bus Voltage based on the input voltage and the control signal. The controlling unit is operable to receive a signal indicative of an output of the converting unit, determine an Intermediate Bus Voltage to reduce power loss in

dependence upon the signal indicative of the output of the converting unit, and generate a control signal for controlling the converting unit to generate the determined Intermediate Bus Voltage.

5

Moreover, the present invention also provides a control method of controlling the Intermediate Bus Voltage in an intermediate bus architecture power system, the method comprising an Intermediate Bus Converter within the intermediate bus architecture power system performing operations of: converting an input voltage to an Intermediate Bus Voltage using a converting unit; receiving a signal indicative of an output of a converting unit; determining an Intermediate Bus Voltage to reduce power loss in dependence upon the signal indicative of an output of the converting unit; 10 generating a control signal to control the converting unit to convert the input voltage to the determined Intermediate Bus Voltage; and generating an Intermediate Bus Voltage in dependence upon the control signal.

As a result of these features the Intermediate Bus Converter itself determines an Intermediate Bus Voltage to reduce power loss and performs voltage control to achieve the determined Intermediate Bus Voltage. Consequently, a Board Power Manager is not required, and the cost of maintenance is reduced. In addition, 25 in embodiments of the present invention the Intermediate Bus Converter may be reprogrammed by a user according to their specific requirements.

[Brief Description of the Drawings]

30

Embodiments of the invention will now be described, by way of example only, with reference to the accompanying drawings in which:

35 Figure 1 is a block diagram of a known Intermediate Bus Architecture power system, in which a Board Power Manager

instructs the Intermediate Bus Converter to vary the Intermediate Bus Voltage.

5 Figure 2 is a block diagram showing an Intermediate Bus Architecture power system with an Intermediate Bus Converter according to a first embodiment of the present invention.

10 Figure 3 is a block diagram showing further detail of the Intermediate Bus Converter according to the first embodiment of the present invention.

Figure 4a is a generalised table, stored in the table storage unit of Figure 3, relating output power to output voltage.

15 Figure 4b is an exemplary table, stored in the table storage unit of Figure 3, relating output power to output voltage.

20 Figure 5 is a flowchart showing the processes performed by the components of the Intermediate Bus Converter of Figure 3.

Figure 6 shows experimental results for an embodiment from a test comparison comparing the system power loss for varying loads between 0W and 300W for varying Intermediate Bus Voltages 9V - 13V.

25 Figure 7 is a generalised table, stored in the table storage unit of Figure 3 in a modified embodiment, relating output current to output voltage.

30 [Detailed Description of Embodiments]

As will be explained in detail below, the present invention proposes an Intermediate Bus Converter for use in an intermediate bus architecture that simplifies the construction and maintenance
35 of the intermediate bus architecture whilst providing improved power efficiency.

Figure 2 depicts a top-level block diagram of an intermediate bus architecture 200 power system in accordance with a first embodiment.

5

Referring to Figure 2, the Intermediate Bus Converter 201 is fed with an input voltage V_{IN} which is then converted to an Intermediate Bus Voltage. The Intermediate Bus Voltage is then fed into a number of Point of Load regulators 202 - 204 which
10 convert the Intermediate Bus Voltage into a plurality of output voltages V_{out1} - V_{out3} , which are applied to external loads (not shown).

In this embodiment of the present invention, it is not necessary
15 to use a Board Power Manager (as depicted in Figure 1) because, as will be explained in detail below, it is the Intermediate Bus Converter itself that takes the appropriate measurements, calculates an Intermediate Bus Voltage to reduce power loss and then adjusts its output accordingly.

20

Figure 3 depicts a more detailed layout of the Intermediate Bus Converter 201 according to the first embodiment of the present invention. In this embodiment, the Intermediate Bus Converter 201 comprises a converting unit 2011 and a controlling unit 2012. In
25 addition, the two optional elements, namely measuring unit 2013 and table storage unit 2014 are also provided in this embodiment.

The converting unit 2011 is operable to receive an input voltage V_{IN} and a control signal D and is operable to generate an
30 Intermediate Bus Voltage based on the input voltage V_{IN} and the control signal D.

The controlling unit 2011 is operable to receive a signal indicative of an output of the converting unit 2011, determine an
35 Intermediate Bus Voltage to reduce power loss in dependence upon the signal indicative of the output of the converting unit 2011,

and generate the control signal D for controlling the converting unit 2011 to generate the determined Intermediate Bus Voltage.

5 The optional measuring unit 2013 is operable to measure an output of the converting unit 2011 on the intermediate bus and is operable to generate the signal indicative of the output of the converting unit 2011. In the present embodiment, the measuring unit 2013 is arranged to measure both the output current I_{out} and the output voltage V_{out} of the Intermediate Bus Converter 201 and generate signals indicative of these outputs, although this is not essential, as explained later. If a measuring unit 2013 is not provided, then the outputs of the converting unit 2011 may be fed directly into the controlling unit 2012. The controlling unit 2012 can then use the outputs of the converting unit 2011 to determine the Intermediate Bus Voltage to reduce power loss.

In this embodiment, the controlling unit 2011 is operable to calculate an output power of the Intermediate Bus Converter 201 in dependence upon the signal indicative of the output current of the converting unit 2011 and in dependence upon the signal indicative of the output voltage of the converting unit 2011. The controlling unit 2011 then determines an Intermediate Bus Voltage to reduce power loss in dependence upon the calculated output power.

25 As a result, this embodiment of the present invention provides an apparatus that allows the controlled variation of the Intermediate Bus Voltage without any external communication to the Point of Load Regulators, removing the need for a Board Power Manager.

30 In this embodiment, the controlling unit is arranged to determine an Intermediate Bus Voltage to reduce power loss using a look-up table stored in the table storage unit 2014. The content of the table may be set during manufacturing and changed, if required, using the Power Management Bus for communication. The content of

the table in effect defines the rules for Intermediate Bus Voltage change.

5 More particularly, the table storage unit 2014 is configured to store a table relating respective outputs of the converting unit 2011 to respective Intermediate Bus Voltages which reduce power loss. The controlling unit is then operable to determine the Intermediate Bus Voltage to reduce power loss by reading an Intermediate Bus Voltage from the stored table in dependence upon
10 the signal indicative of the output of the converting unit 2011.

Figure 4a shows a generalised table, stored in the table storage unit of Figure 3, relating respective output powers of the converting unit 2011 to output voltages (Intermediate Bus
15 Voltages).

By way of example, Figure 4b shows an exemplary table, stored in the table storage unit of Figure 3, with exemplary real world values relating respective output powers of the converting unit
20 2011 to output voltages (Intermediate Bus Voltages). The table shows how the output voltage of the Intermediate Bus Converter should be changed over various power ranges, as calculated by the controlling unit 2012.

25 Accordingly, when controlling unit 2012 calculates an output power of the converting unit 2011 to be in the range 0 - 120W, then the controlling unit 2012 determines from the table that the output voltage of the converting unit 2011 (Intermediate Bus Voltage) that would reduce power loss should be 7V. Thereby, the
30 controlling unit 2012 generates a control signal D to control the converting unit 2011 to set the output voltage to 7V. Similarly, if the calculated output power of the converting unit is in the range 120W - 160W then the controlling unit 2012 determines that the output voltage of the converting unit 2011 to reduce power
35 loss is 9V. If the calculated power is in the range 160W - MAX then the controlling unit 2012 determines that the output voltage

of the converting unit 2011 should be 12V. It will be appreciated that these values are merely exemplary and appropriate values of the power and output voltage can be set in a table at manufacture and by the user during operation according to the desired use.

From the above, it will therefore be understood that the output voltage change is based on output current received by the controlling unit 2011 integrated in DC/DC Intermediate Bus Converter. This function is configured as a hex decimal block in manufacturing command registers and is in linear format.

The present embodiment of the invention allows the output power to be measured internally with the digital control circuit on the Intermediate Bus Converter, instead of obtaining information from the Point of Load Regulators. This permits the removal of the Board Power Manager.

Since the dynamic Intermediate Bus Voltage is controlled by a table, it operates in a similar fashion to a state machine and can be configured to be turned ON or OFF. As a result, changes are fast, creating less noise in the Intermediate Bus Voltage. In addition, this dynamic Intermediate Bus Voltage function will not affect other functions such as current limiting, current sharing etc.

This present embodiment of the invention, due to the use of digital control, allows a configurable slew rate of the output voltage when changing the bus voltage. This is important since it allows the control of the inrush current and current sink, and permits a stable change when using active current sharing and not affecting the output voltage of the Point of Load Regulator with sudden voltage steps.

The controlling unit 2012 could also work as a master to communicate with other PMBus devices and use information from Point of Load Regulators to make decisions how to change the output voltage.

A change in the system loading, i.e. the power that the Intermediate Bus Voltage is required to supply, may result in a change of the Intermediate Bus Voltage. If the load increases,
5 then this can cause the Intermediate Bus Voltage to increase.

The controlling unit 2012 would typically be configured to continuously monitor the signal indicative of the output voltage and/or the signal indicative of the output current of the converting unit 2011 and change the Intermediate Bus Voltage
10 whenever the controlling unit 2012 detects a significant change in the load.

For example, if the controlling unit 2012 detects that the load has increased, then the controlling unit 2012 would increase the Intermediate Bus Voltage and thereby prevent the Intermediate Bus
15 Voltage from limiting the maximum output power.

Typically, the controlling unit 2012 would be capable of changing the Intermediate Bus Voltage one hundred to a thousand times per second.

The determination of whether the Intermediate Bus Voltage should
20 be changed may use thresholds to avoid the effects of noise. For example, the Intermediate Bus Voltage may only be changed when the monitored output voltage is more than a few hundred millivolts.

Using new technologies such as digitally controlled and digitally
25 managed Intermediate Bus Converters and Point of Load Regulators there will be more information available in the power system. This information includes information such as momentary input and output currents, input and output voltages, and duty cycle of the Point of Load Regulators and the Intermediate Bus Converters.

Dynamic control of the Intermediate Bus Voltage can occur soon after the power system is powered on. After ramp up, which means that the power system has received a "power system initialization completed and successful" signal (which, for example, can be
5 "Power Good received") then a measurement of output current is performed and an output voltage is set through the table configuration.

Figure 5 shows a flowchart of the processing operations performed
10 by the Intermediate Bus Converter 201 of Figure 3 to control the Intermediate Bus Voltage in an intermediate bus architecture 200 power system.

Referring to Figure 5, at step S501 an input voltage V_{in} is
15 converted to an Intermediate Bus Voltage by the converting unit 2011.

At step S502 at least one output on the intermediate bus is measured and used to generate a signal indicative of the measured
20 output. In the present embodiment, the outputs of the Intermediate Bus Converter 201 that are measured are the output current I_{out} and the output voltage V_{out} of the converting unit 2011.

At step S503 an Intermediate Bus Voltage to reduce power loss is
25 determined in dependence upon the signal indicative of the measured output of the converting unit 2011. In the present embodiment, an output power of an Intermediate Bus Converter 201 is calculated in dependence upon the signal indicative of an
30 output current I_{out} of the converting unit 2011 and in dependence upon the signal indicative of an output voltage V_{out} of the converting unit (2011). An Intermediate Bus Voltage to reduce power loss is determined in dependence upon this calculated output power.

At step S504 a control signal D is generated to control the converting unit 2011 to convert the input voltage to the determined Intermediate Bus Voltage. This control signal D is then sent to the converting unit 2011.

5

At step S505 an Intermediate Bus Voltage is generated by the converting unit 2011 in dependence upon the input voltage V_{IN} and the control signal D.

10 Figure 5 shows a single set of processing operations from measuring at least one output of the converting unit 2011 to generating an Intermediate Bus Voltage. The single set of processing operations is shown to end after step S505.

15 However, as described earlier, controlling unit 2012 would typically continuously monitor at least one output of the converting unit 2011 and determine if the Intermediate Bus Voltage should be changed. For such an arrangement, the processing operations would not end after step S505 but loop back
20 to step S501 so that the processing operations are repeated endlessly.

Experimental Results

25

Figure 6 depicts experimental results for an embodiment of the invention showing how the power losses vary according to system loading for various Intermediate Bus Voltages.

30 As can be seen in the graph, for no load then a voltage of 9V is best, since this minimises power losses. However, for loads greater than 150W load, a crossover point occurs and it is more advantageous to use an Intermediate Bus Voltage of 12V.

35

[Modifications and Variants]

Many modifications and variations can be made to the embodiments described above, without departing from the scope of the present invention.

For example, it is not necessary for the measuring unit 2013 and the controlling unit 2012 (depicted in Figure 3) to be separate units. Instead, the measuring unit 2013 and the controlling unit 2012 may be formed as an integral unit.

Although the output current and output voltage of the Intermediate Bus Converter are measured (in order to calculate an output power) in the embodiment above, it is not necessary to measure and utilise both of these outputs, and instead only one output may be measured and utilised. For example, an embodiment may measure and utilise the output current of the Intermediate Bus Converter, alone. A table based upon the output current can then be used to determine an Intermediate Bus Voltage to reduce power loss. An exemplary version of this table is depicted in Figure 7.

Optionally, it is possible for the controlling unit 2011 to use an algorithm, instead of a table, to calculate the Intermediate Bus Voltage to reduce power loss by executing the algorithm. The controlling unit 2011 may thereby generate a control signal to instruct the converting unit 2011 to change its output voltage based the result of executing the algorithm.

Exemplary algorithms are shown below in Equations 1 and 2.

$$V_{IB} = k_1 \times P_{out} + m_1$$

(Equation 1)

$$V_{IB} = k_2 \times P_{out}^2 + m_2$$

(Equation 2)

In these equations V_{IB} is the Intermediate Bus Voltage output from the Intermediate Bus Converter, P_{out} is the measured output power from the Intermediate Bus Converter, k is the gain factor and m is the offset.

- 5 In a real-world scenario, the constants may be: $k_1 = 3.2E-5$, $m_1 = 7$, $k_2 = 0.127$ and $m_2 = 7$.

These equations permit the calculation of the Intermediate Bus Voltage to reduce power loss without the use of a table.

- 10 The foregoing description of embodiments of the present invention has been presented for the purpose of illustration and description. It is not intended to be exhaustive or to limit the invention to the present form disclosed. Alternations, modifications and variations can be made without departing from
15 the spirit and scope of the present invention.

Claims:

1. An intermediate bus converter (201) operable to generate an intermediate bus voltage (V_{IB}) for use in an intermediate bus architecture (200) power system, the intermediate bus converter (201) comprising:
- 5
- a converting unit (2011) operable to receive an input voltage (V_{IN}) and a control signal (D) and operable to generate an intermediate bus voltage (V_{IB}) based on the input voltage (V_{IN}) and the control signal (D); and
- 10
- a controlling unit (2012) operable to receive a signal indicative of an output of the converting unit (2011), determine an intermediate bus voltage (V_{IB}) to reduce power loss in dependence upon the signal indicative of the output of the converting unit (2011), and generate a control signal (D) for controlling the converting unit (2011) to generate the determined intermediate bus voltage (V_{IB}).
- 15
- 20
2. An intermediate bus converter (201) according to Claim 1, further comprising:
- 25
- a measuring unit (2013) operable to measure an output of the converting unit (2011) and operable to generate the signal indicative of the output of the converting unit (2011).
- 30
3. An intermediate bus converter (201) according to Claim 2, wherein the measuring unit (2013) is operable to measure the output current (I_{out}) on the intermediate bus.
- 35

4. An intermediate bus converter (201) according to Claim 2 or Claim 3, wherein the measuring unit (2013) is operable to measure the output voltage (V_{out}) on the intermediate bus.

5

5. An intermediate bus converter (201) according to Claim 4 when dependent upon Claim 3, wherein the controlling unit (2012) is operable to calculate an output power of the intermediate bus converter (201) in dependence upon the output current of the converting unit (2011) and in dependence upon the output voltage of the converting unit (2011), and wherein the controlling unit (2012) is operable to determine the intermediate bus voltage (V_{IB}) to reduce power loss in dependence upon the calculated output power.

10

15

6. An intermediate bus converter (201) according to Claim 5, wherein the controlling unit (2012) is operable to detect a change in the calculated output power of the intermediate bus converter (201) and to determine the intermediate bus voltage (V_{IB}) in dependence upon the detected change in the calculated output power.

20

7. An intermediate bus converter (201) according to any of Claims 2 to 6, wherein the controlling unit (2012) and the measuring unit (2013) are formed as an integral unit.

25

8. An intermediate bus converter (201) according to any preceding claim, further comprising:

a table storage unit (2014) configured to store a table relating respective outputs of the converting unit (2011) to respective intermediate bus voltages which reduce power loss;

30

35

and wherein the controlling unit (2012) is operable to determine the intermediate bus voltage (V_{IB}) to reduce power loss by reading an intermediate bus voltage (V_{IB}) from the stored table in dependence upon the signal indicative of the output of the converting unit (2011).

5

9. An intermediate bus converter (201) according to any one of claims 1 to 7, wherein the controlling unit (2012) is operable to calculate the intermediate bus voltage to reduce power loss by executing an algorithm.

10

10. An intermediate bus architecture (200) power system having an intermediate bus converter (201) according to any preceding claim.

15

11. A control method of controlling the intermediate bus voltage (V_{IB}) in an intermediate bus architecture (200) power system, the method comprising an intermediate bus converter (201) within the intermediate bus architecture (200) power system performing operations of:

20

25 converting an input voltage (V_{IN}) to an intermediate bus voltage using a converting unit (S501);

25

receiving a signal indicative of an output of a converting unit (S502);

30

determining an intermediate bus voltage (V_{IB}) to reduce power loss in dependence upon the signal indicative of an output of the converting unit (S503);

35

generating a control signal (D) to control the converting unit (2011) to convert the input voltage

(V_{IN}) to the determined intermediate bus voltage (S504); and

5 generating an intermediate bus voltage (V_{IB}) in dependence upon the control signal (S505).

12. A control method according to Claim 11, wherein:

10 the method further comprises, measuring an output of the converting unit (2011); and

the signal indicative of an output of the converting unit (2011) is generated in dependence upon the measured output.

15

13. A control method according to Claim 12, wherein an output current (I_{out}) on the intermediate bus is measured.

20 14. A control method according to Claim 12 or Claim 13, wherein an output voltage (V_{out}) on the intermediate bus is measured.

25 15. A control method according to Claim 14 when dependent upon Claim 13, wherein:

30 the method further comprises, calculating an output power of the intermediate bus converter (201) in dependence upon the output current (I_{out}) of the converting unit (2011) and in dependence upon the output voltage (V_{out}) of the converting unit (2011); and

35 the intermediate bus voltage (V_{IB}) to reduce power loss is determined in dependence upon the calculated output power.

16. A control method according to Claim 15, wherein:

5 the method further comprises detecting a change in the calculated output power of the intermediate bus converter (201); and

10 the intermediate bus voltage (V_{IB}) is determined in dependence upon the detected change in the calculated output power.

17. A control method according to any one of Claims 11 to 16, wherein the intermediate bus voltage (V_{IB}) to reduce power loss is determined by reading a value from a stored table relating respective outputs of
15 the converting unit (2011) to respective intermediate bus voltages (V_{IB}) which reduce power loss, in dependence upon the signal indicative of the output of the converting unit (2011).

20 18. A control method according to any one of Claim 11 to 16, wherein the intermediate bus voltage (V_{IB}) to reduce power loss is calculated by executing an algorithm.

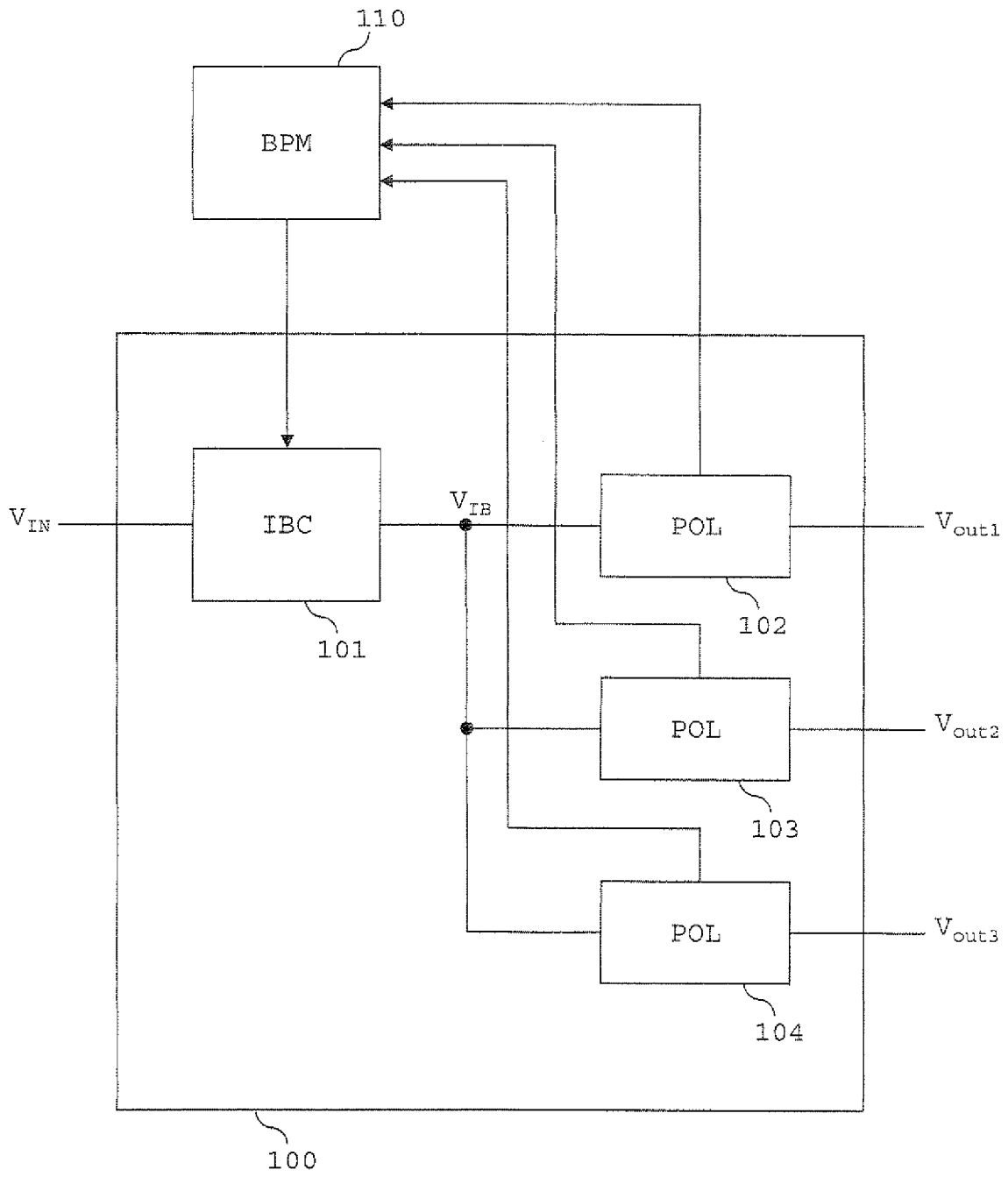

Fig. 1

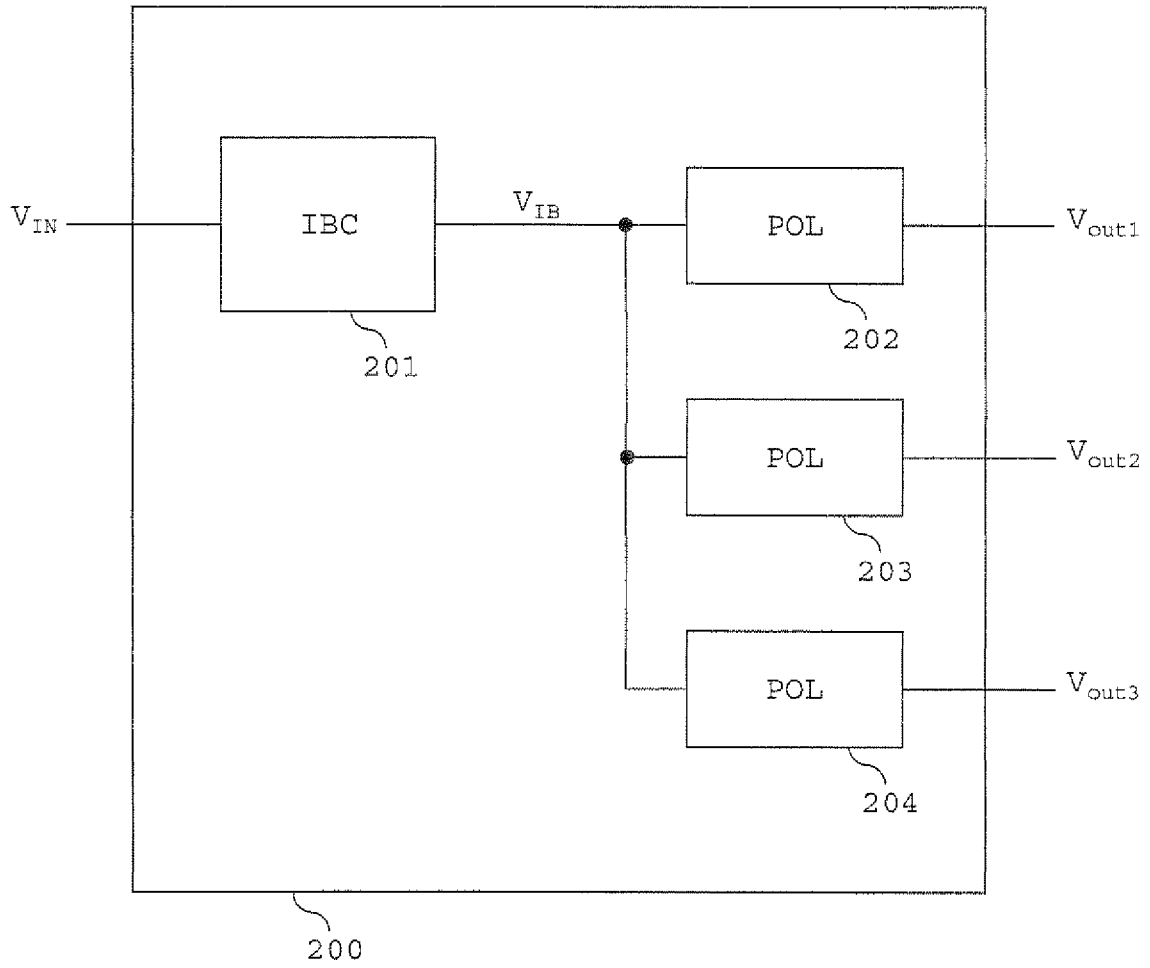

Fig. 2

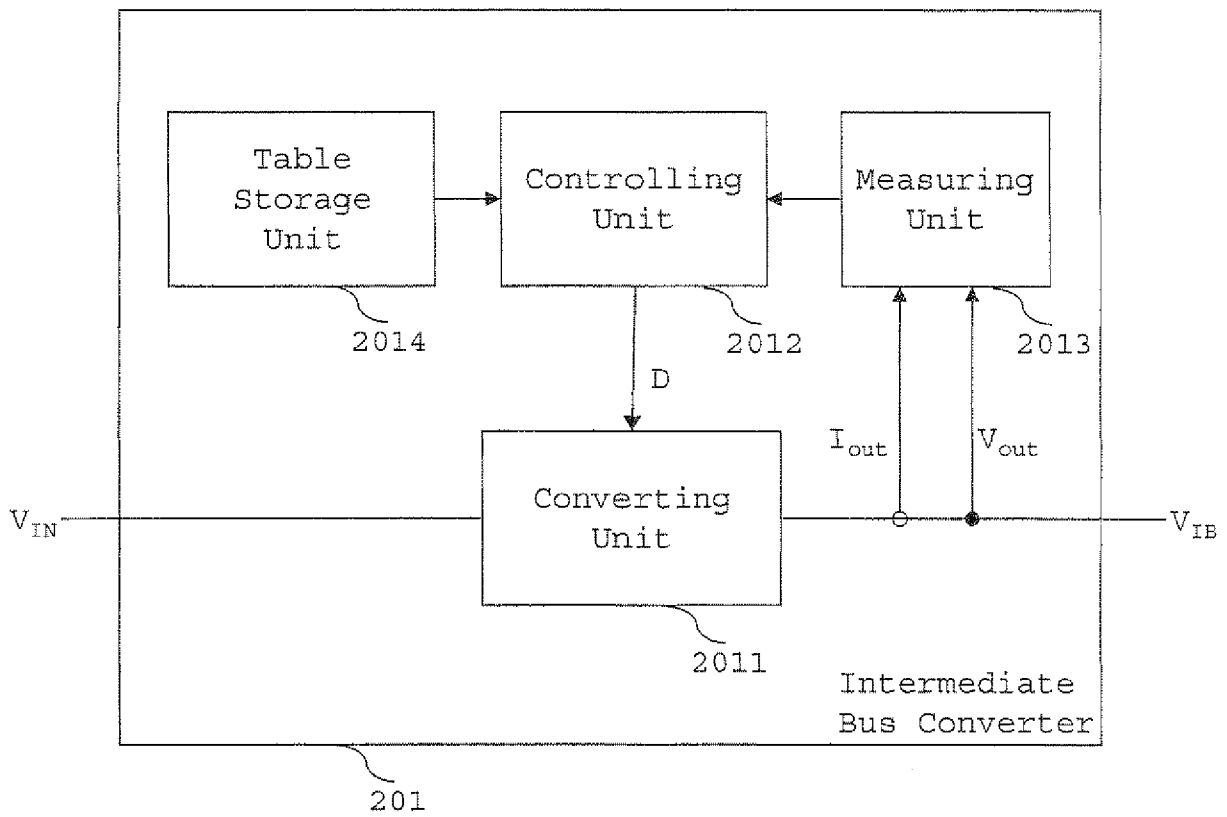

Fig. 3

Output Power (W)	Low output power region 0 - P1	Middle output power region 0 - P2	High output power region 0 - P3
Output Voltage (V)	Set bus voltage to V1	Set bus voltage to V2	Set bus voltage to V3

Fig. 4a

Output Power (W)	0 - 120	120 - 160	160 - Max
Output Voltage (V)	7	9	12

Fig. 4b

5/7

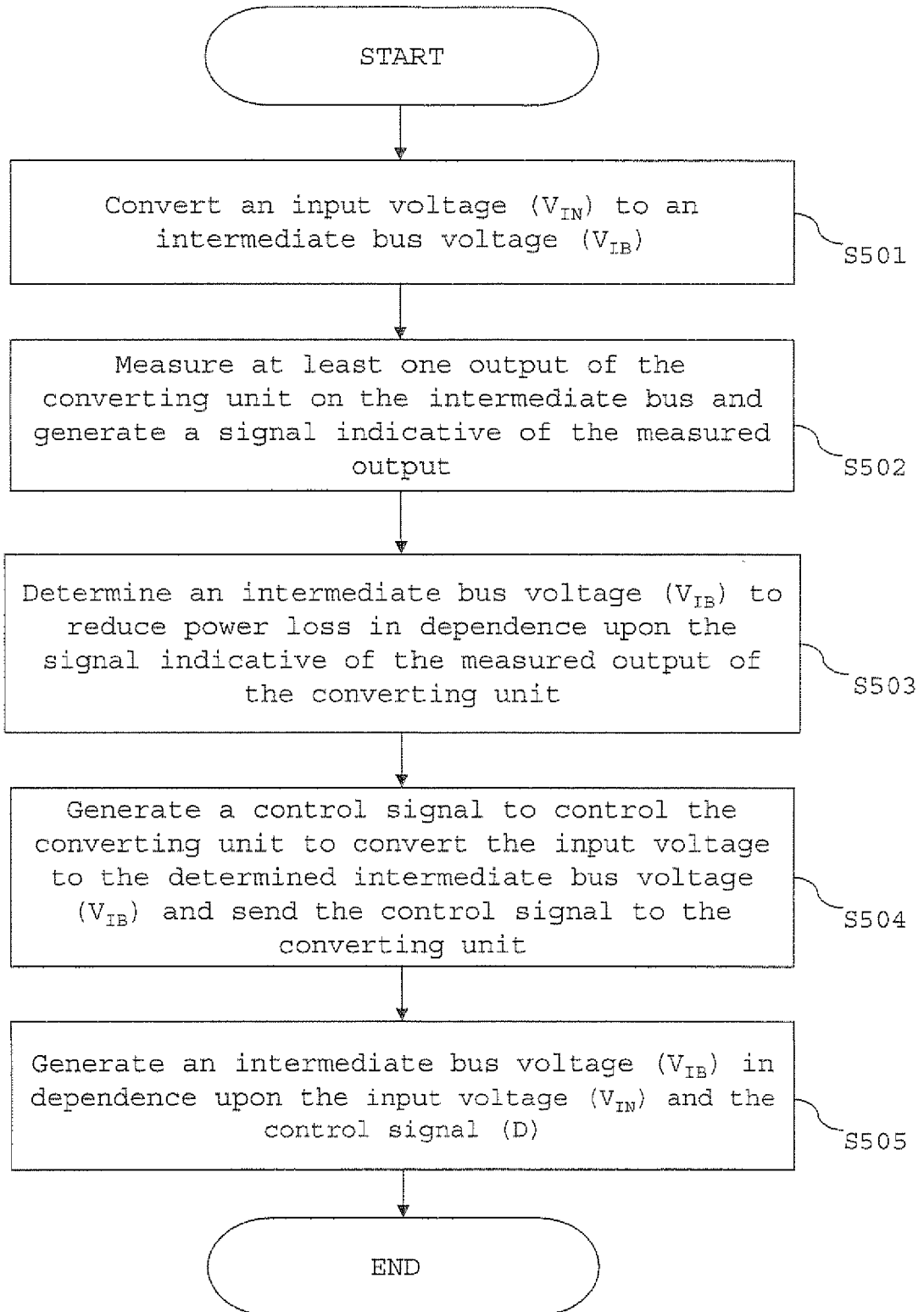

Fig. 5

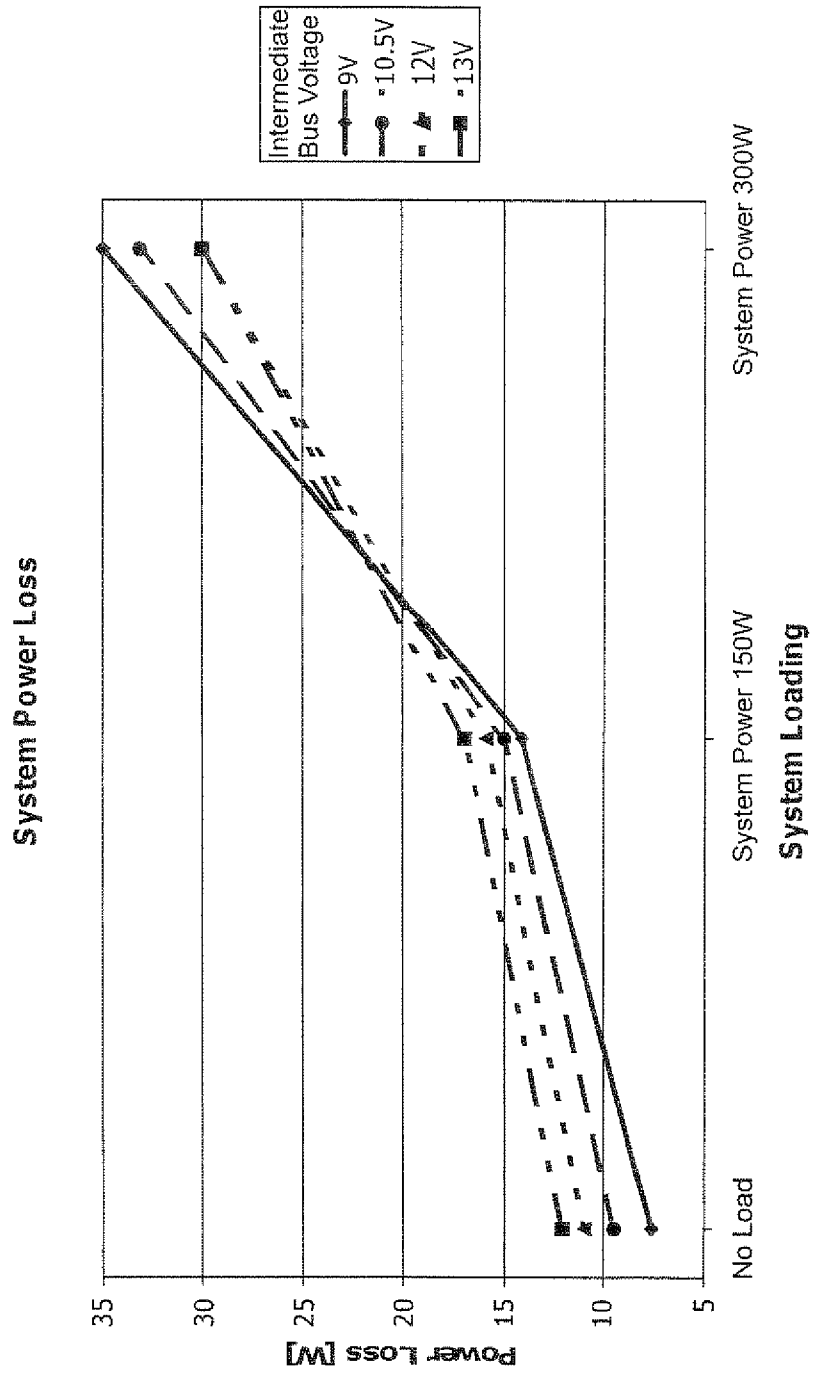

Fig. 6

7/7

Output Current (A)	Low output current region 0 - I1	Middle output current region 0 - I2	High output current region 0 - I3
Output Voltage (V)	Set bus voltage to V1	Set bus voltage to V2	Set bus voltage to V3

Fig. 7