



(51) International Patent Classification:

*C08H 8/00* (2010.01)     *D21C 3/20* (2006.01)  
*D21C 3/04* (2006.01)     *C08B 1/00* (2006.01)  
*D21C 3/22* (2006.01)     *C08B 37/14* (2006.01)

(21) International Application Number:

PCT/US2013/076384

(22) International Filing Date:

19 December 2013 (19.12.2013)

(25) Filing Language:

English

(26) Publication Language:

English

(30) Priority Data:

61/747,771     31 December 2012 (31.12.2012)     US  
14/105,889     13 December 2013 (13.12.2013)     US

(71) Applicant: API INTELLECTUAL PROPERTY HOLDINGS, LLC [US/US]; Attn: Ryan O'Connor, 750 Piedmont Ave. NE, Atlanta, Georgia 30308 (US).

(72) Inventor: O'CONNOR, Ryan; 2608 North Saunders Lake Drive, Minnetrista, Minnesota 55364 (US).

(74) Agent: O'CONNOR, Ryan; API Intellectual Property Holdings, LLC, 750 Piedmont Ave. NE, Atlanta, Georgia 30308 (US).

(81) Designated States (unless otherwise indicated, for every kind of national protection available): AE, AG, AL, AM, AO, AT, AU, AZ, BA, BB, BG, BH, BN, BR, BW, BY, BZ, CA, CH, CL, CN, CO, CR, CU, CZ, DE, DK, DM, DO, DZ, EC, EE, EG, ES, FI, GB, GD, GE, GH, GM, GT,

HN, HR, HU, ID, IL, IN, IR, IS, JP, KE, KG, KN, KP, KR, KZ, LA, LC, LK, LR, LS, LT, LU, LY, MA, MD, ME, MG, MK, MN, MW, MX, MY, MZ, NA, NG, NI, NO, NZ, OM, PA, PE, PG, PH, PL, PT, QA, RO, RS, RU, RW, SA, SC, SD, SE, SG, SK, SL, SM, ST, SV, SY, TH, TJ, TM, TN, TR, TT, TZ, UA, UG, US, UZ, VC, VN, ZA, ZM, ZW.

(84) Designated States (unless otherwise indicated, for every kind of regional protection available): ARIPO (BW, GH, GM, KE, LR, LS, MW, MZ, NA, RW, SD, SL, SZ, TZ, UG, ZM, ZW), Eurasian (AM, AZ, BY, KG, KZ, RU, TJ, TM), European (AL, AT, BE, BG, CH, CY, CZ, DE, DK, EE, ES, FI, FR, GB, GR, HR, HU, IE, IS, IT, LT, LU, LV, MC, MK, MT, NL, NO, PL, PT, RO, RS, SE, SI, SK, SM, TR), OAPI (BF, BJ, CF, CG, CI, CM, GA, GN, GQ, GW, KM, ML, MR, NE, SN, TD, TG).

Declarations under Rule 4.17:

- as to the identity of the inventor (Rule 4.17(i))
- as to applicant's entitlement to apply for and be granted a patent (Rule 4.17(ii))
- as to the applicant's entitlement to claim the priority of the earlier application (Rule 4.17(iii))
- of inventorship (Rule 4.17(iv))

Published:

- with international search report (Art. 21(3))

[Continued on next page]

(54) Title: BIOREFINING PROCESSES AND APPARATUS FOR SEPARATING CELLULOSE, HEMICELLULOSE, AND LIGNIN FROM BIOMASS

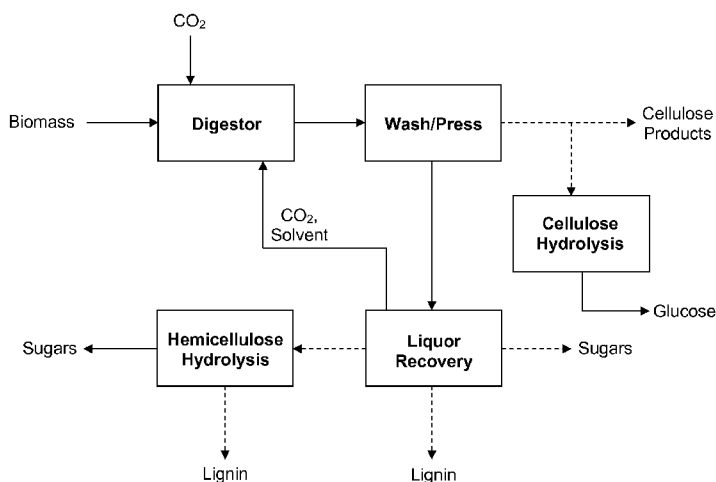

(57) Abstract: The disclosed invention is a modification of the AVAP®? technology, employing CO<sub>2</sub> (or derivatives thereof) rather than SO<sub>2</sub> in the cooking liquor. In some variations, the invention provides a process for fractionating cellulosic biomass into cellulose, hemicellulose, and lignin, comprising: fractionating the feedstock in the presence of a solvent for lignin, carbon dioxide, and water, to produce a liquor containing hemicellulose, cellulose-rich solids, and lignin; substantially removing the cellulose-rich solids from the liquor; hydrolyzing the hemicellulose contained in the liquor, to produce hemicellulosic monomers; hydrolyzing at least some of the cellulose-rich solids to produce glucose (or recovering the cellulose-rich solids as a cellulose product); recovering the hemicellulosic monomers to produce fermentable sugars; and recovering the lignin which may be in the form of a lignocarbonate.

WO 2014/105601 A1

- *before the expiration of the time limit for amending the claims and to be republished in the event of receipt of amendments (Rule 48.2(h))*

**BIOREFINING PROCESSES AND APPARATUS FOR SEPARATING  
CELLULOSE, HEMICELLULOSE, AND LIGNIN FROM BIOMASS**

**PRIORITY DATA**

**[0001]** This international patent application claims priority to U.S. Patent App. No. 14/105,889, filed December 13, 2013, and to U.S. Provisional Patent App. No. 61/747,771, filed December 31, 2012, each of which is hereby incorporated by reference herein.

**FIELD**

**[0002]** The present invention generally relates to fractionation processes for converting biomass into fermentable sugars, cellulose, and lignin.

**BACKGROUND**

**[0003]** Biomass refining (or biorefining) is becoming more prevalent in industry. Cellulose fibers and sugars, hemicellulose sugars, lignin, syngas, and derivatives of these intermediates are being used by many companies for chemical and fuel production. Indeed, we now are observing the commercialization of integrated biorefineries that are capable of processing incoming biomass much the same as petroleum refineries now process crude oil. Underutilized lignocellulosic biomass feedstocks have the potential to be much cheaper than petroleum, on a carbon basis, as well as much better from an environmental life-cycle standpoint.

**[0004]** Lignocellulosic biomass is the most abundant renewable material on the planet and has long been recognized as a potential feedstock for producing chemicals, fuels, and materials. Lignocellulosic biomass normally comprises primarily cellulose, hemicellulose, and lignin. Cellulose and hemicellulose are

natural polymers of sugars, and lignin is an aromatic/aliphatic hydrocarbon polymer reinforcing the entire biomass network. Some forms of biomass (e.g., recycled materials) do not contain hemicellulose.

**[0005]** There are many reasons why it would be beneficial to process biomass in a way that effectively separates the major fractions (cellulose, hemicellulose, and lignin) from each other. Cellulose from biomass can be used in industrial cellulose applications directly, such as to make paper or other pulp-derived products. The cellulose can also be subjected to further processing to either modify the cellulose in some way or convert it into glucose. Hemicellulose sugars can be fermented to a variety of products, such as ethanol, or converted to other chemicals. Lignin from biomass has value as a solid fuel and also as an energy feedstock to produce liquid fuels, synthesis gas, or hydrogen; and as an intermediate to make a variety of polymeric compounds. Additionally, minor components such as proteins or rare sugars can be extracted and purified for specialty applications.

**[0006]** In light of this objective, a major shortcoming of previous process technologies is that one or two of the major components can be economically recovered in high yields, but not all three. Either the third component is sacrificially degraded in an effort to produce the other two components, or incomplete fractionation is accomplished. An important example is traditional biomass pulping (to produce paper and related goods). Cellulose is recovered in high yields, but lignin is primarily consumed by oxidation and hemicellulose sugars are mostly degraded. Approximately half of the starting biomass is essentially wasted in this manufacturing process. State-of-the-art biomass-pretreatment approaches typically can produce high yields of hemicellulose sugars but suffer from moderate cellulose and lignin yields.

**[0007]** There are several possible pathways to convert biomass into intermediates. One thermochemical pathway converts the feedstock into syngas (CO and H<sub>2</sub>) through gasification or partial oxidation. Another thermochemical pathway converts biomass into liquid bio-oils through pyrolysis and separation. These are both high-temperature processes that intentionally destroy sugars in biomass.

**[0008]** Sugars (e.g., glucose and xylose) are desirable platform molecules because they can be fermented to a wide variety of fuels and chemicals, used to grow organisms or produce enzymes, converted catalytically to chemicals, or recovered and

sold to the market. To recover sugars from biomass, the cellulose and/or the hemicellulose in the biomass must be hydrolyzed into sugars. This is a difficult task because lignin and hemicelluloses are bound to each other by covalent bonds, and the three components are arranged inside the fiber wall in a complex manner. This recalcitrance explains the natural resistance of woody biomass to decomposition, and explains the difficulty to convert biomass to sugars at high yields.

**[0009]** Fractionation of biomass into its principle components (cellulose, hemicellulose, and lignin) has several advantages. Fractionation of lignocellulosics leads to release of cellulosic fibers and opens the cell wall structure by dissolution of lignin and hemicellulose between the cellulose microfibrils. The fibers become more accessible for hydrolysis by enzymes. When the sugars in lignocellulosics are used as feedstock for fermentation, the process to open up the cell wall structure is often called “pretreatment.” Pretreatment can significantly impact the production cost of lignocellulosic ethanol.

**[0010]** One of the most challenging technical obstacles for cellulose has been its recalcitrance towards hydrolysis for glucose production. Because of the high quantity of enzymes typically required, the enzyme cost can be a tremendous burden on the overall cost to turn cellulose into glucose for fermentation. Cellulose can be made to be reactive by subjecting biomass to severe chemistry, but that would jeopardize not only its integrity for other potential uses but also the yields of hemicellulose and lignin.

**[0011]** Many types of pretreatment have been studied. A common chemical pretreatment process employs a dilute acid, usually sulfuric acid, to hydrolyze and extract hemicellulose sugars and some lignin. A common physical pretreatment process employs steam explosion to mechanically disrupt the cellulose fibers and promote some separation of hemicellulose and lignin. Combinations of chemical and physical pretreatments are possible, such as acid pretreatment coupled with mechanical refining. It is difficult to avoid degradation of sugars. In some cases, severe pretreatments (i.e., high temperature and/or low pH) intentionally dehydrate sugars to furfural, levulinic acid, and related chemicals. Also, in common acidic pretreatment approaches, lignin handling is very problematic because acid-condensed lignin precipitates and forms deposits on surfaces throughout the process.

[0012] One type of pretreatment that can overcome many of these disadvantages is called “organosolv” pretreatment. Organosolv refers to the presence of an organic solvent for lignin, which allows the lignin to remain soluble for better lignin handling. Traditionally, organosolv pretreatment or pulping has employed ethanol-water solutions to extract most of the lignin but leave much of the hemicellulose attached to the cellulose. For some market pulps, it is acceptable or desirable to have high hemicellulose content in the pulp. When high sugar yields are desired, however, there is a problem. Traditional ethanol/water pulping cannot give high yields of hemicellulose sugars because the timescale for sufficient hydrolysis of hemicellulose to monomers causes soluble-lignin polymerization and then precipitation back onto cellulose, which negatively impacts both pulp quality as well as cellulose enzymatic digestibility.

[0013] An acid catalyst can be introduced into organosolv pretreatment to attempt to hydrolyze hemicellulose into monomers while still obtaining the solvent benefit. Conventional organosolv wisdom dictates that high delignification can be achieved, but that a substantial fraction of hemicellulose must be left in the solids because any catalyst added to hydrolyze the hemicellulose will necessarily degrade the sugars (e.g., to furfural) during extraction of residual lignin.

[0014] Commercial sulfite pulping has been practiced since 1874. The focus of sulfite pulping is the preservation of cellulose. In an effort to do that, industrial variants of sulfite pulping take 6-10 hours to dissolve hemicelluloses and lignin, producing a low yield of fermentable sugars. Stronger acidic cooking conditions that hydrolyze the hemicellulose to produce a high yield of fermentable sugars also hydrolyze the cellulose, and therefore the cellulose is not preserved.

[0015] The dominant pulping process today is the Kraft process. Kraft pulping does not fractionate lignocellulosic material into its primary components. Instead, hemicellulose is degraded in a strong solution of sodium hydroxide with or without sodium sulfide. The cellulose pulp produced by the Kraft process is high quality, essentially at the expense of both hemicellulose and lignin.

[0016] Sulfite pulping produces spent cooking liquor termed sulfite liquor. Fermentation of sulfite liquor to hemicellulosic ethanol has been practiced primarily to reduce the environmental impact of the discharges from sulfite mills since 1909.

However, ethanol yields do not exceed one-third of the original hemicellulose component. Ethanol yield is low due to the incomplete hydrolysis of the hemicelluloses to fermentable sugars and further compounded by sulfite pulping side products, such as furfural, methanol, acetic acid, and others fermentation inhibitors.

**[0017]** Solvent cooking chemicals have been attempted as an alternative to Kraft or sulfite pulping. The original solvent process is described in U.S. Patent No. 1,856,567 by Kleinert et al. Groombridge et al. in U.S. Patent No. 2,060,068 showed that an aqueous solvent with sulfur dioxide is a potent delignifying system to produce cellulose from lignocellulosic material. Three demonstration facilities for ethanol-water (Alcell), alkaline sulfite with anthraquinone and methanol (ASAM), and ethanol-water-sodium hydroxide (Organocell) were operated briefly in the 1990s.

**[0018]** In view of the state of the art, what is desired is to efficiently fractionate any lignocellulosic-based biomass (including, in particular, softwoods) into its primary components so that each can be used in potentially distinct processes. While not all commercial products require pure forms of cellulose, hemicellulose, or lignin, a platform biorefinery technology that enables processing flexibility in downstream optimization of product mix, is particularly desirable. An especially flexible fractionation technique would not only separate most of the hemicellulose and lignin from the cellulose, but also render the cellulose highly reactive to cellulase enzymes for the manufacture of fermentable glucose.

## SUMMARY

**[0019]** The present invention addresses the aforementioned needs in the art.

**[0020]** In some variations, the invention provides a process for fractionating cellulosic biomass into cellulose, hemicellulose, and lignin, the process comprising:

- (a) providing a feedstock comprising lignocellulosic biomass;
- (b) in a digester, fractionating the feedstock under effective fractionation conditions in the presence of a solvent for lignin, carbon dioxide, and water, to produce a liquor containing hemicellulose, cellulose-rich solids, and lignin;
- (c) substantially removing the cellulose-rich solids from the liquor;

- (d) hydrolyzing the hemicellulose contained in the liquor, under effective hydrolysis conditions, to produce hemicellulosic monomers;
- (e) optionally hydrolyzing at least some of the cellulose-rich solids to produce glucose;
- (f) optionally recovering at least some of the cellulose-rich solids as a cellulose product;
- (g) recovering the hemicellulosic monomers, and optionally the glucose if step (e) is conducted, to produce fermentable sugars; and
- (h) recovering the lignin.

**[0021]** In some embodiments, the invention provides a process for fractionating cellulosic biomass into cellulose, hemicellulose, and lignin, the process comprising:

- (a) providing a feedstock comprising lignocellulosic biomass;
- (b) in a digester, fractionating the feedstock under effective fractionation conditions in the presence of a solvent for lignin, carbonic acid, and water, to produce a liquor containing hemicellulose, cellulose-rich solids, and lignin;
- (c) substantially removing the cellulose-rich solids from the liquor;
- (d) hydrolyzing the hemicellulose contained in the liquor, under effective hydrolysis conditions, to produce hemicellulosic monomers;
- (e) optionally hydrolyzing at least some of the cellulose-rich solids to produce glucose;
- (f) optionally recovering at least some of the cellulose-rich solids as a cellulose product;
- (g) recovering the hemicellulosic monomers, and optionally the glucose if step (e) is conducted, to produce fermentable sugars; and
- (h) recovering the lignin.

**[0022]** In some embodiments, the invention provides a process for fractionating cellulosic biomass into cellulose, hemicellulose, and lignin, the process comprising:

- (a) providing a feedstock comprising lignocellulosic biomass;
- (b) in a digester, fractionating the feedstock under effective fractionation conditions in the presence of a solvent for lignin, water, and a carbonate dianion or

salt thereof and/or a bicarbonate anion or salt thereof, to produce a liquor containing hemicellulose, cellulose-rich solids, and lignin;

(c) substantially removing the cellulose-rich solids from the liquor;

(d) hydrolyzing the hemicellulose contained in the liquor, under effective hydrolysis conditions, to produce hemicellulosic monomers;

(e) optionally hydrolyzing at least some of the cellulose-rich solids to produce glucose;

(f) optionally recovering at least some of the cellulose-rich solids as a cellulose product;

(g) recovering the hemicellulosic monomers, and optionally the glucose if step (e) is conducted, to produce fermentable sugars; and

(h) recovering the lignin.

**[0023]** The process may further comprise fermenting the fermentable sugars to a fermentation product and CO<sub>2</sub>. In some embodiments, this CO<sub>2</sub> may be utilized in step (b), in free form, dissolved form, or reacted form. In certain embodiments, the fermentation product is ethanol, and step (b) utilizes recycled ethanol as the solvent for lignin, as well as recycled CO<sub>2</sub> from fermentation.

**[0024]** Optionally, the process may further include introducing a different acid (i.e. not CO<sub>2</sub> or a derivative thereof) to step (b), step (d), and/or step (e). Such acid may be a sulfur-containing acid, such as sulfuric acid, sulfurous acid, or sulfur dioxide. Alternatively, or additionally, one or more enzymes may be added to step (b), step (d), and/or step (e).

**[0025]** In some embodiments, the cellulose-rich solids are further extracted with an additional acid after removing the cellulose-rich solids from the primary digester liquor. These embodiments may be advantageous to remove initial sugars formed, and then further extract the solids with potentially a stronger acid, such as sulfur dioxide or sulfuric acid.

**[0026]** In some embodiments, a portion of the lignin recovered in step (h) is a lignocarbonate, formed in the digester from reactions between carbon dioxide and lignin. A portion of the lignin may be native lignin.

## BRIEF DESCRIPTION OF THE FIGURES

[0027] FIG. 1 is an exemplary block-flow diagram of some embodiments of the invention to fractionate biomass into cellulose, hemicellulose, and lignin, comprising digestion with carbon dioxide and a solvent for lignin.

[0028] FIG. 2 is an exemplary block-flow diagram of some embodiments of the invention to fractionate biomass into cellulose, hemicellulose, and lignin, comprising digestion with carbon dioxide and a solvent for lignin followed by secondary extraction.

## DETAILED DESCRIPTION OF SOME EMBODIMENTS

[0029] This description will enable one skilled in the art to make and use the invention, and it describes several embodiments, adaptations, variations, alternatives, and uses of the invention. These and other embodiments, features, and advantages of the present invention will become more apparent to those skilled in the art when taken with reference to the following detailed description of the invention in conjunction with any accompanying drawings.

[0030] As used in this specification and the appended claims, the singular forms “a,” “an,” and “the” include plural referents unless the context clearly indicates otherwise. Unless defined otherwise, all technical and scientific terms used herein have the same meaning as is commonly understood by one of ordinary skill in the art to which this invention belongs. All composition numbers and ranges based on percentages are weight percentages, unless indicated otherwise. All ranges of numbers or conditions are meant to encompass any specific value contained within the range, rounded to any suitable decimal point.

[0031] Unless otherwise indicated, all numbers expressing parameters, reaction conditions, concentrations of components, and so forth used in the specification and claims are to be understood as being modified in all instances by the term “about.” Accordingly, unless indicated to the contrary, the numerical parameters

set forth in the following specification and attached claims are approximations that may vary depending at least upon a specific analytical technique.

**[0032]** The term “comprising,” which is synonymous with “including,” “containing,” or “characterized by” is inclusive or open-ended and does not exclude additional, unrecited elements or method steps. “Comprising” is a term of art used in claim language which means that the named claim elements are essential, but other claim elements may be added and still form a construct within the scope of the claim.

**[0033]** As used herein, the phrase “consisting of” excludes any element, step, or ingredient not specified in the claim. When the phrase “consists of” (or variations thereof) appears in a clause of the body of a claim, rather than immediately following the preamble, it limits only the element set forth in that clause; other elements are not excluded from the claim as a whole. As used herein, the phrase “consisting essentially of” limits the scope of a claim to the specified elements or method steps, plus those that do not materially affect the basis and novel characteristic(s) of the claimed subject matter.

**[0034]** With respect to the terms “comprising,” “consisting of,” and “consisting essentially of,” where one of these three terms is used herein, the presently disclosed and claimed subject matter may include the use of either of the other two terms. Thus in some embodiments not otherwise explicitly recited, any instance of “comprising” may be replaced by “consisting of” or, alternatively, by “consisting essentially of.”

**[0035]** The present invention, in some variations, is premised on the realization that rather than (or in addition to) sulfur dioxide, carbon dioxide may be used along with water and a solvent for lignin in a variation of the AVAP® technology. Carbon dioxide has certain environmental, health, and safety advantages over sulfur dioxide, including lower toxicity and relative acceptability to emit to the environment. Also, CO<sub>2</sub> offers lower cost (for make-up cooking chemicals) and the ability to recycle from downstream fermentation that produces CO<sub>2</sub>. On the other hand, carbon dioxide and its derivatives (e.g., carbonic acid) in solution tend to be weaker acids for hydrolysis, necessitating more-severe reactor conditions if the same degree of biomass fractionation is desired. CO<sub>2</sub> is by no means a simple substitution for SO<sub>2</sub>.

**[0036]** In some variations, the invention provides a process for fractionating cellulosic biomass into cellulose, hemicellulose, and lignin, the process comprising:

- (a) providing a feedstock comprising lignocellulosic biomass;
- (b) in a digester, fractionating the feedstock under effective fractionation conditions in the presence of a solvent for lignin, carbon dioxide, and water, to produce a liquor containing hemicellulose, cellulose-rich solids, and lignin;
- (c) substantially removing the cellulose-rich solids from the liquor;
- (d) hydrolyzing the hemicellulose contained in the liquor, under effective hydrolysis conditions, to produce hemicellulosic monomers;
- (e) optionally hydrolyzing at least some of the cellulose-rich solids to produce glucose;
- (f) optionally recovering at least some of the cellulose-rich solids as a cellulose product;
- (g) recovering the hemicellulosic monomers, and optionally the glucose if step (e) is conducted, to produce fermentable sugars; and
- (h) recovering the lignin.

**[0037]** In some embodiments, the invention provides a process for fractionating cellulosic biomass into cellulose, hemicellulose, and lignin, the process comprising:

- (a) providing a feedstock comprising lignocellulosic biomass;
- (b) in a digester, fractionating the feedstock under effective fractionation conditions in the presence of a solvent for lignin, carbonic acid, and water, to produce a liquor containing hemicellulose, cellulose-rich solids, and lignin;
- (c) substantially removing the cellulose-rich solids from the liquor;
- (d) hydrolyzing the hemicellulose contained in the liquor, under effective hydrolysis conditions, to produce hemicellulosic monomers;
- (e) optionally hydrolyzing at least some of the cellulose-rich solids to produce glucose;
- (f) optionally recovering at least some of the cellulose-rich solids as a cellulose product;
- (g) recovering the hemicellulosic monomers, and optionally the glucose if step (e) is conducted, to produce fermentable sugars; and

(h) recovering the lignin.

**[0038]** In some embodiments, the invention provides a process for fractionating cellulosic biomass into cellulose, hemicellulose, and lignin, the process comprising:

(a) providing a feedstock comprising lignocellulosic biomass;

(b) in a digester, fractionating the feedstock under effective fractionation conditions in the presence of a solvent for lignin, water, and a carbonate dianion or salt thereof and/or a bicarbonate anion or salt thereof, to produce a liquor containing hemicellulose, cellulose-rich solids, and lignin;

(c) substantially removing the cellulose-rich solids from the liquor;

(d) hydrolyzing the hemicellulose contained in the liquor, under effective hydrolysis conditions, to produce hemicellulosic monomers;

(e) optionally hydrolyzing at least some of the cellulose-rich solids to produce glucose;

(f) optionally recovering at least some of the cellulose-rich solids as a cellulose product;

(g) recovering the hemicellulosic monomers, and optionally the glucose if step (e) is conducted, to produce fermentable sugars; and

(h) recovering the lignin.

**[0039]** The process may further comprise fermenting the fermentable sugars to a fermentation product and CO<sub>2</sub>. In some embodiments, this CO<sub>2</sub> may be utilized in step (b), in free form, dissolved form, or reacted form. In certain embodiments, the fermentation product is ethanol, and step (b) utilizes recycled ethanol as the solvent for lignin, as well as the CO<sub>2</sub> from fermentation.

**[0040]** In some embodiments, a portion of the lignin recovered in step (h) is a lignocarbonate, formed in the digester from reactions between carbon dioxide and lignin.

**[0041]** Optionally, the process may further include introducing a different acid (i.e. not CO<sub>2</sub> or a derivative thereof) to step (b), step (d), and/or step (e). Such acid may be a sulfur-containing acid, such as sulfuric acid, sulfurous acid, or sulfur dioxide. Alternatively, or additionally, one or more enzymes may be added to step (b), step (d), and/or step (e).

**[0042]** This disclosure describes processes and apparatus to efficiently fractionate any lignocellulosic-based biomass into its primary major components (cellulose, lignin, and if present, hemicellulose) so that each can be used in potentially distinct processes. An advantage of the process is that it produces cellulose-rich solids while concurrently producing a liquid phase containing a high yield of both hemicellulose sugars and lignin, and low quantities of lignin and hemicellulose degradation products. The flexible fractionation technique enables multiple uses for the products. The cellulose is highly reactive to cellulase enzymes for the manufacture of glucose. Other uses for celluloses can be adjusted based on market conditions.

**[0043]** Certain exemplary embodiments of the invention will now be described. These embodiments are not intended to limit the scope of the invention as claimed. The order of steps may be varied, some steps may be omitted, and/or other steps may be added. Reference herein to first step, second step, etc. is for illustration purposes only.

**[0044]** FIG. 1 is an exemplary block-flow diagram of some embodiments of the invention to fractionate biomass into cellulose, hemicellulose, and lignin, comprising digestion with carbon dioxide and a solvent for lignin. FIG. 2 is an exemplary block-flow diagram of some embodiments of the invention to fractionate biomass into cellulose, hemicellulose, and lignin, comprising digestion with carbon dioxide and a solvent for lignin followed by secondary extraction. Secondary extraction may be utilized due to the lower acidity provided by CO<sub>2</sub>, with intermediate separation of the initial liquor to preserve sugars that are released initially. Secondary extraction may utilize SO<sub>2</sub> or other acids.

**[0045]** The biomass feedstock may be selected from hardwoods, softwoods, forest residues, industrial wastes, pulp and paper wastes, consumer wastes, or combinations thereof. Some embodiments utilize agricultural residues, which include lignocellulosic biomass associated with food crops, annual grasses, energy crops, or other annually renewable feedstocks. Exemplary agricultural residues include, but are not limited to, corn stover, corn fiber, wheat straw, sugarcane bagasse, sugarcane straw, rice straw, oat straw, barley straw, miscanthus, energy cane straw/residue, or combinations thereof.

**[0046]** As used herein, “lignocellulosic biomass” means any material containing cellulose and lignin. Lignocellulosic biomass may also contain hemicellulose. Mixtures of one or more types of biomass can be used. In some embodiments, the biomass feedstock comprises both a lignocellulosic component (such as one described above) in addition to a sucrose-containing component (e.g., sugarcane or energy cane) and/or a starch component (e.g., corn, wheat, rice, etc.).

**[0047]** Various moisture levels may be associated with the starting biomass. The biomass feedstock need not be, but may be, relatively dry. In general, the biomass is in the form of a particulate or chip, but particle size is not critical in this invention.

**[0048]** Reaction conditions and operation sequences may vary widely. Some embodiments employ conditions described in U.S. Patent No. 8,030,039, issued Oct. 4, 2011; U.S. Patent No. 8,038,842, issued Oct. 11, 2011; U.S. Patent No. 8,268,125, issued Sept. 18, 2012; and U.S. Patent App. Nos. 13/004,431; 12/234,286; 13/585,710; 12/250,734; 12/397,284; 12/304,046; 13/500,916; 13/626,220; 12/854,869; 61/732,047; 61/735,738; 61/739,343; 61/747,010; 61/747,105; 61/747,376; 61/747,379; 61/747,382; 61/747,408; and 61/747,566. Each of these commonly owned patent applications is hereby incorporated by reference herein in its entirety. In some embodiments, the process is a variation (including, but not limited to, replacement of SO<sub>2</sub> with CO<sub>2</sub>) of the AVAP® process technology which is commonly owned with the assignee of this patent application.

**[0049]** In some embodiments, a first process step is “cooking” (equivalently, “digesting”) which fractionates the three lignocellulosic material components (cellulose, hemicellulose, and lignin) to allow easy downstream removal. Specifically, hemicelluloses are dissolved and a portion is completely hydrolyzed to monomers; cellulose is separated but remains resistant to hydrolysis; and part of the lignin is carbonated into water-soluble lignocarbonates.

**[0050]** The lignocellulosic material is processed in a solution (cooking liquor) of aliphatic alcohol, water, and carbon dioxide. The cooking liquor preferably contains at least 10 wt%, such as at least 20 wt%, 30 wt%, 40 wt%, or 50 wt% of a solvent for lignin. For example, the cooking liquor may contain about 30-70 wt% solvent, such as about 50 wt% solvent. The solvent for lignin may be an aliphatic

alcohol, such as methanol, ethanol, 1-propanol, 2-propanol, 1-butanol, 2-butanol, isobutanol, 1-pentanol, 1-hexanol, or cyclohexanol. The solvent for lignin may be an aromatic alcohol, such as phenol or cresol. Other lignin solvents are possible, such as (but not limited to) glycerol, methyl ethyl ketone, or diethyl ether. Ionic liquids may also be employed as the solvent for lignin. Combinations of more than one solvent may be employed.

**[0051]** Preferably, enough solvent is included in the extractant mixture to dissolve the lignin present in the starting material. The solvent for lignin may be completely miscible, partially miscible, or immiscible with water, so that there may be more than one liquid phase. Potential process advantages arise when the solvent is miscible with water, and also when the solvent is immiscible with water. When the solvent is water-miscible, a single liquid phase forms, so mass transfer of lignin and hemicellulose extraction is enhanced, and the downstream process must only deal with one liquid stream. When the solvent is immiscible in water, the extractant mixture readily separates to form liquid phases, so a distinct separation step can be avoided or simplified. This can be advantageous if one liquid phase contains most of the lignin and the other contains most of the hemicellulose sugars, as this facilitates recovering the lignin from the hemicellulose sugars.

**[0052]** The cooking liquor preferably contains carbon dioxide and/or carbonic acid ( $\text{H}_2\text{CO}_3$ ). The cooking liquor preferably contains  $\text{CO}_2$ , in free, dissolved, or reacted form, in a concentration of at least 1 wt%, preferably at least 4 wt%, more preferably at least 8 wt%, such as about 9 wt%, 10 wt%, 11 wt%, 12 wt%, 13 wt%, 14 wt%, 15 wt%, 20 wt%, 25 wt%, 30 wt% or higher. The cooking liquor may also contain one or more species, separately from  $\text{CO}_2$ , to adjust the pH. The pH of the cooking liquor is typically about 7 or less, such as about 6.5, 6, 5.5, 5.0, 4.5, 4.0, 3.5, 3.0, 2.5, or 2.0.

**[0053]** Carbon dioxide is a preferred acid catalyst, because it can be recovered easily from solution after hydrolysis. The majority of the  $\text{CO}_2$  from the hydrolysate may be stripped and recycled back to the reactor. Recovery and recycling translates to less base required compared to neutralization of a strong acid, less solids to dispose of, and less separation equipment. Less acid usage also will translate into lower costs for a base (e.g., lime) to increase the pH following hydrolysis, for downstream

operations. Furthermore, less acid and less base will also mean substantially less generation of waste salts (e.g., calcium carbonate) that may otherwise require disposal.

**[0054]** In some embodiments, an additive may be included in amounts of about 0.1 wt% to 10 wt% or more to increase cellulose viscosity. Exemplary additives include ammonia, ammonia hydroxide, urea, anthraquinone, magnesium oxide, magnesium hydroxide, sodium hydroxide, and their derivatives.

**[0055]** The cooking is performed in one or more stages using batch or continuous digestors. Solid and liquid may flow cocurrently or countercurrently, or in any other flow pattern that achieves the desired fractionation. The cooking reactor may be internally agitated, if desired.

**[0056]** Depending on the lignocellulosic material to be processed, the cooking conditions are varied, with temperatures from about 100°C to 250°C, for example 110°C, 120°C, 130°C, 140°C, 150°C, 160°C, 170°C, 180°C, 190°C, 200°C, 210°C, 220°C, 230°C, or 240°C and corresponding pressures at equilibrium. The cooking time of one or more stages may be selected from about 15 minutes to about 720 minutes, such as about 30, 45, 60, 90, 120, 140, 160, 180, 250, 300, 360, 450, 550, 600, or 700 minutes. Generally, there is an inverse relationship between the temperature used during the digestion step and the time needed to obtain good fractionation of the biomass into its constituent parts.

**[0057]** The cooking liquor to lignocellulosic material ratio may be selected from about 1 to about 10, such as about 2, 2.5, 3, 3.5, 4, or 5. In some embodiments, biomass is digested in a pressurized vessel with low liquor volume (low ratio of cooking liquor to lignocellulosic material), so that the cooking space is filled with ethanol and carbon dioxide vapor in equilibrium with moisture. The cooked biomass is washed in alcohol-rich solution to recover lignin and dissolved hemicelluloses, while the remaining pulp is further processed. In some embodiments, the process of fractionating lignocellulosic material comprises vapor-phase cooking of lignocellulosic material with aliphatic alcohol (or other solvent for lignin), water, and carbon dioxide. See, for example, U.S. Patent Nos. 8,038,842 and 8,268,125 which are incorporated by reference herein, with the SO<sub>2</sub> being replaced by CO<sub>2</sub> in embodiments of the present invention.

[0058] A portion or all of the carbon dioxide may be present as carbonic acid in the extract liquor. In certain embodiments, carbon dioxide is generated *in situ* by introducing carbonic acid, carbonate ions, bicarbonate ions, combinations thereof, or a salt of any of the foregoing. In some embodiments, a derivative of carbon dioxide is utilized, rather than CO<sub>2</sub> itself. CO<sub>2</sub> derivatives include, but are not limited to, carbonic acid, carbonates (in ionic or salt form), bicarbonates (in ionic or salt form), lignocarbonic acids, and any other molecules that may be derived chemically from CO<sub>2</sub>, such as oxalic acid (H<sub>2</sub>C<sub>2</sub>O<sub>4</sub>).

[0059] Excess carbon dioxide, following hydrolysis, may be recovered and reused. Carbon dioxide has a relatively low solubility in water, so a significant portion of the CO<sub>2</sub> present may be undissolved and may circulate as bubbles through the digester, for example. Sonication may be utilized to assist in separation of CO<sub>2</sub> following hydrolysis.

[0060] In some embodiments, carbon dioxide is saturated in water (or aqueous solution, optionally with an alcohol) at a first temperature, and the hydrolysis is then carried out at a second, generally higher, temperature. In some embodiments, carbon dioxide is sub-saturated. In some embodiments, carbon dioxide is super-saturated. In some embodiments, carbon dioxide concentration is selected to achieve a certain degree of lignin carbonation, such as 1%, 2%, 3%, 4%, 5%, 6%, 7%, 8%, 9%, or 10% lignocarbonate content. CO<sub>2</sub> may react chemically with lignin to form stable lignocarbonic acids which may be present both in the solid and liquid phases.

[0061] The concentration of carbon dioxide, additives, and aliphatic alcohol (or other solvent) in the solution and the time of cook may be varied to control the yield of cellulose and hemicellulose in the pulp. The concentration of carbon dioxide and the time of cook may be varied to control the yield of lignin versus lignocarbonates in the hydrolysate. In some embodiments, the concentration of carbon dioxide, temperature, and the time of cook may be varied to control the yield of fermentable sugars.

[0062] Once the desired amount of fractionation of both hemicellulose and lignin from the solid phase is achieved, the liquid and solid phases are separated. Conditions for the separation may be selected to minimize the reprecipitation of the extracted lignin on the solid phase. This is favored by conducting separation or

washing at a temperature of at least the glass-transition temperature of lignin (about 120°C).

**[0063]** The physical separation can be accomplished either by transferring the entire mixture to a device that can carry out the separation and washing, or by removing only one of the phases from the reactor while keeping the other phase in place. The solid phase can be physically retained by appropriately sized screens through which liquid can pass. The solid is retained on the screens and can be kept there for successive solid-wash cycles. Alternately, the liquid may be retained and solid phase forced out of the reaction zone, with centrifugal or other forces that can effectively transfer the solids out of the slurry. In a continuous system, countercurrent flow of solids and liquid can accomplish the physical separation.

**[0064]** The recovered solids normally will contain a quantity of lignin and sugars, some of which can be removed easily by washing. The washing-liquid composition can be the same as or different than the liquor composition used during fractionation. Multiple washes may be performed to increase effectiveness. Preferably, one or more washes are performed with a composition including a solvent for lignin, to remove additional lignin from the solids, followed by one or more washes with water to displace residual solvent and sugars from the solids. Recycle streams, such as from solvent-recovery operations, may be used to wash the solids.

**[0065]** After separation and washing as described, a solid phase and at least one liquid phase are obtained. The solid phase contains substantially undigested cellulose. A single liquid phase is usually obtained when the solvent and the water are miscible in the relative proportions that are present. In that case, the liquid phase contains, in dissolved form, most of the lignin originally in the starting lignocellulosic material, as well as soluble monomeric and oligomeric sugars formed in the hydrolysis of any hemicellulose that may have been present. Multiple liquid phases tend to form when the solvent and water are wholly or partially immiscible. The lignin tends to be contained in the liquid phase that contains most of the solvent. Hemicellulose hydrolysis products tend to be present in the liquid phase that contains most of the water.

**[0066]** In some embodiments, hydrolysate from the cooking step is subjected to pressure reduction. Pressure reduction may be done at the end of a cook in a batch

digestor, or in an external flash tank after extraction from a continuous digester, for example. The flash vapor from the pressure reduction may be collected into a cooking liquor make-up vessel. The flash vapor contains substantially all the unreacted carbon dioxide which may be directly dissolved into new cooking liquor. The cellulose is then removed to be washed and further treated as desired.

**[0067]** A process washing step recovers the hydrolysate from the cellulose. The washed cellulose is pulp that may be used for various purposes (e.g., paper or nanocellulose production). The weak hydrolysate from the washer continues to the final reaction step; in a continuous digester this weak hydrolysate may be combined with the extracted hydrolysate from the external flash tank. In some embodiments, washing and/or separation of hydrolysate and cellulose-rich solids is conducted at a temperature of at least about 100°C, 110°C, or 120°C. The washed cellulose may also be used for glucose production via cellulose hydrolysis with enzymes or acids.

**[0068]** In another reaction step, the hydrolysate may be further treated in one or multiple steps to hydrolyze the oligomers into monomers. This step may be conducted before, during, or after the removal of solvent and carbon dioxide. The solution may or may not contain residual solvent (e.g. alcohol). In some embodiments, carbon dioxide is added or allowed to pass through to this step, to assist hydrolysis. In these or other embodiments, another acid such as SO<sub>2</sub>, sulfurous acid, or sulfuric acid is introduced to assist with hydrolysis. In some embodiments, the hydrolysate is autohydrolyzed by heating under pressure. In some embodiments, no additional acid is introduced, but lignocarbonic acids produced during the initial cooking are effective to catalyze hydrolysis of hemicellulose oligomers to monomers. In various embodiments, this step utilizes carbon dioxide or derivatives thereof at a concentration of about 0.01 wt% to 30 wt%, such as about 0.05 wt%, 0.1 wt%, 0.2 wt%, 0.5 wt%, 1 wt%, 2 wt%, 5 wt%, 10 wt%, or 20 wt%. This step may be carried out at a temperature from about 100°C to 220°C, such as about 110°C, 120°C, 130°C, 140°C, 150°C, 160°C, 170°C, 180°C, 190°C, 200°C, or 210°C. Heating may be direct or indirect to reach the selected temperature.

**[0069]** The reaction step produces fermentable sugars which can then be concentrated by evaporation to a fermentation feedstock. Concentration by evaporation may be accomplished before, during, or after the treatment to hydrolyze

oligomers. The final reaction step may optionally be followed by steam stripping of the resulting hydrolysate to remove and recover carbon dioxide and alcohol, and for removal of potential fermentation-inhibiting side products. The evaporation process may be under vacuum or pressure, from about -0.1 atmospheres to about 10 atmospheres, such as about 0.1 atm, 0.3 atm, 0.5 atm, 1.0 atm, 1.5 atm, 2 atm, 4 atm, 6 atm, or 8 atm.

**[0070]** Recovering and recycling the carbon dioxide may utilize separations such as, but not limited to, vapor-liquid disengagement (e.g. flashing), steam stripping, extraction, or combinations or multiple stages thereof. Various recycle ratios may be practiced, such as about 0.1, 0.2, 0.3, 0.4, 0.5, 0.6, 0.7, 0.8, 0.9, 0.95, or more. In some embodiments, about 90-99% of initially charged CO<sub>2</sub> is readily recovered by distillation from the liquid phase, with the remaining 1-10% (e.g., about 3-5%) of the CO<sub>2</sub> primarily bound to dissolved lignin in the form of lignocarbonates.

**[0071]** In a preferred embodiment, the evaporation step utilizes an integrated alcohol stripper and evaporator. Evaporated vapor streams may be segregated so as to have different concentrations of organic compounds in different streams. Evaporator condensate streams may be segregated so as to have different concentrations of organic compounds in different streams. Alcohol may be recovered from the evaporation process by condensing the exhaust vapor and returning to the cooking liquor make-up vessel in the cooking step. Clean condensate from the evaporation process may be used in the washing step.

**[0072]** In some embodiments, an integrated alcohol stripper and evaporator system is employed, wherein aliphatic alcohol is removed by vapor stripping, the resulting stripper product stream is concentrated by evaporating water from the stream, and evaporated vapor is compressed using vapor compression and is reused to provide thermal energy.

**[0073]** The hydrolysate from the evaporation and final reaction step contains mainly fermentable sugars but may also contain lignin depending on the location of lignin separation in the overall process configuration. The hydrolysate may be concentrated to a concentration of about 5 wt% to about 60 wt% solids, such as about 10 wt%, 15 wt%, 20 wt%, 25 wt%, 30 wt%, 35 wt%, 40 wt%, 45 wt%, 50 wt% or 55 wt% solids. The hydrolysate contains fermentable sugars.

**[0074]** Fermentable sugars are defined as hydrolysis products of cellulose, galactoglucomannan, glucomannan, arabinoglucuronoxylans, arabinogalactan, and glucuronoxylans into their respective short-chained oligomers and monomer products, i.e., glucose, mannose, galactose, xylose, and arabinose. The fermentable sugars may be recovered in purified form, as a sugar slurry or dry sugar solids, for example. Any known technique may be employed to recover a slurry of sugars or to dry the solution to produce dry sugar solids.

**[0075]** In some embodiments, the fermentable sugars are fermented to produce biochemicals or biofuels such as (but by no means limited to) ethanol, isopropanol, acetone, 1-butanol, isobutanol, 1,4-butanediol, lactic acid, succinic acid, or any other fermentation products. Some amount of the fermentation product may be a microorganism or enzymes, which may be recovered if desired.

**[0076]** In some embodiments, the process further comprises recovering the lignin as a co-product. Carbonated lignin may also be recovered as a co-product. In certain embodiments, the process further comprises combusting or gasifying the carbonated lignin, recovering carbon contained in the carbonated lignin in a gas stream comprising reclaimed carbon dioxide, and then recycling the reclaimed carbon dioxide for reuse.

**[0077]** The process lignin separation step is for the separation of lignin from the hydrolysate and can be located before or after the final reaction step and evaporation. If located after, then lignin will precipitate from the hydrolysate since alcohol has been removed in the evaporation step. The remaining water-soluble lignocarbonates may be precipitated by converting the hydrolysate to an alkaline condition (pH higher than 7) using, for example, an alkaline earth oxide, preferably calcium oxide (lime). The combined lignin and lignocarbonate precipitate may be filtered. The lignin and lignocarbonate filter cake may be dried as a co-product or burned or gasified for energy production. The hydrolysate from filtering may be recovered and sold as a concentrated sugar solution product or further processed in a subsequent fermentation or other reaction step.

**[0078]** Native (non-carbonated) lignin is hydrophobic, while lignocarbonates are expected to be hydrophilic. Hydrophilic lignocarbonates may have less propensity to clump, agglomerate, and stick to surfaces. Even lignocarbonates that do undergo

some condensation and increase of molecular weight, will still have an  $\text{HCO}_3$  group that will contribute some solubility (hydrophilic).

**[0079]** In some embodiments, the soluble lignin precipitates from the hydrolysate after solvent has been removed in the evaporation step. In some embodiments, reactive lignocarbonates are selectively precipitated from hydrolysate using excess lime (or other base, such as ammonia) in the presence of aliphatic alcohol. In some embodiments, hydrated lime is used to precipitate lignocarbonates. In some embodiments, part of the lignin is precipitated in reactive form and the remaining lignin is carbonated in water-soluble form.

**[0080]** The process fermentation and distillation steps are intended for the production of fermentation products, such as alcohols or organic acids. After removal of cooking chemicals and lignin, and further treatment (oligomer hydrolysis), the hydrolysate contains mainly fermentable sugars in water solution from which any fermentation inhibitors have been preferably removed or neutralized. The hydrolysate is fermented to produce dilute alcohol or organic acids, from 1 wt% to 20 wt% concentration. The dilute product is distilled or otherwise purified as is known in the art.

**[0081]** When alcohol is produced, such as ethanol, some of it may be used for cooking liquor makeup in the process cooking step. Also, in some embodiments, a distillation column stream, such as the bottoms, with or without evaporator condensate, may be reused to wash cellulose. In some embodiments, lime may be used to dehydrate product alcohol. Side products may be removed and recovered from the hydrolysate. These side products may be isolated by processing the vent from the final reaction step and/or the condensate from the evaporation step. Side products include furfural, hydroxymethyl furfural (HMF), methanol, acetic acid, and lignin-derived compounds, for example.

**[0082]** The cellulose-rich material is expected to be reactive in the presence of industrial cellulase enzymes that efficiently break the cellulose down to glucose monomers. The glucose may be fermented to an alcohol, an organic acid, or another fermentation product. The glucose may be used as a sweetener or isomerized to enrich its fructose content. The glucose may be used to produce baker's yeast. The

glucose may be catalytically or thermally converted to various organic acids and other materials.

**[0083]** In some embodiments, the cellulose-rich material is further processed into one more cellulose products. Cellulose products include market pulp, dissolving pulp (also known as  $\alpha$ -cellulose), fluff pulp, purified cellulose, paper, paper products, and so on. Further processing may include bleaching, if desired. Further processing may include modification of fiber length or particle size, such as when producing nanocellulose or nanofibrillated or microfibrillated cellulose. It is believed that the cellulose produced by this process is highly amenable to derivatization chemistry for cellulose derivatives and cellulose-based materials such as polymers.

**[0084]** When hemicellulose is present in the starting biomass, all or a portion of the liquid phase contains hemicellulose sugars and soluble oligomers. It is preferred to remove most of the lignin from the liquid, as described above, to produce a fermentation broth which will contain water, possibly some of the solvent for lignin, hemicellulose sugars, and various minor components from the digestion process. This fermentation broth can be used directly, combined with one or more other fermentation streams, or further treated. Further treatment can include sugar concentration by evaporation; addition of glucose or other sugars (optionally as obtained from cellulose saccharification); addition of various nutrients such as salts, vitamins, or trace elements; pH adjustment; and removal of fermentation inhibitors such as acetic acid and phenolic compounds. The choice of conditioning steps should be specific to the target product(s) and microorganism(s) employed.

**[0085]** In some embodiments, hemicellulose sugars are not fermented but rather are recovered and purified, stored, sold, or converted to a specialty product. Xylose, for example, can be converted into xylitol.

**[0086]** A lignin product can be readily obtained from a liquid phase using one or more of several methods. One simple technique is to evaporate off all liquid, resulting in a solid lignin-rich residue. This technique would be especially advantageous if the solvent for lignin is water-immiscible. Another method is to cause the lignin to precipitate out of solution. Some of the ways to precipitate the lignin include (1) removing the solvent for lignin from the liquid phase, but not the water, such as by selectively evaporating the solvent from the liquid phase until the

lignin is no longer soluble; (2) diluting the liquid phase with water until the lignin is no longer soluble; and (3) adjusting the temperature and/or pH of the liquid phase. Methods such as centrifugation can then be utilized to capture the lignin. Yet another technique for removing the lignin is continuous liquid-liquid extraction to selectively remove the lignin from the liquid phase, followed by removal of the extraction solvent to recover relatively pure lignin.

**[0087]** Lignin produced in accordance with the invention can be used as a fuel. As a solid fuel, lignin is similar in energy content to coal. Lignin can act as an oxygenated component in liquid fuels, to enhance octane while meeting standards as a renewable fuel. The lignin produced herein can also be used as polymeric material, and as a chemical precursor for producing lignin derivatives. The carbonated lignin may be sold as a lignocarbonate product, or burned for fuel value.

**[0088]** The present invention also provides systems configured for carrying out the disclosed processes, and compositions produced therefrom. Any stream generated by the disclosed processes may be partially or completely recovered, purified or further treated, and/or marketed or sold.

**[0089]** In this detailed description, reference has been made to multiple embodiments of the invention and non-limiting examples relating to how the invention can be understood and practiced. Other embodiments that do not provide all of the features and advantages set forth herein may be utilized, without departing from the spirit and scope of the present invention. This invention incorporates routine experimentation and optimization of the methods and systems described herein. Such modifications and variations are considered to be within the scope of the invention defined by the claims.

**[0090]** All publications, patents, and patent applications cited in this specification are herein incorporated by reference in their entirety as if each publication, patent, or patent application were specifically and individually put forth herein.

**[0091]** Where methods and steps described above indicate certain events occurring in certain order, those of ordinary skill in the art will recognize that the ordering of certain steps may be modified and that such modifications are in accordance with the variations of the invention. Additionally, certain of the steps may

be performed concurrently in a parallel process when possible, as well as performed sequentially.

**[0092]** Therefore, to the extent there are variations of the invention, which are within the spirit of the disclosure or equivalent to the inventions found in the appended claims, it is the intent that this patent will cover those variations as well. The present invention shall only be limited by what is claimed.

## CLAIMS

What is claimed is:

1. A process for fractionating cellulosic biomass into cellulose, hemicellulose, and lignin, said process comprising:
  - (a) providing a feedstock comprising lignocellulosic biomass;
  - (b) in a digester, fractionating said feedstock under effective fractionation conditions in the presence of a solvent for lignin, carbon dioxide, and water, to produce a liquor containing hemicellulose, cellulose-rich solids, and lignin;
  - (c) substantially removing said cellulose-rich solids from said liquor;
  - (d) hydrolyzing said hemicellulose contained in said liquor, under effective hydrolysis conditions, to produce hemicellulosic monomers;
  - (e) optionally hydrolyzing at least some of said cellulose-rich solids to produce glucose;
  - (f) optionally recovering at least some of said cellulose-rich solids as a cellulose product;
  - (g) recovering said hemicellulosic monomers, and optionally said glucose if step (e) is conducted, to produce fermentable sugars; and
  - (h) recovering said lignin.
  
2. A process for fractionating cellulosic biomass into cellulose, hemicellulose, and lignin, said process comprising:
  - (a) providing a feedstock comprising lignocellulosic biomass;
  - (b) in a digester, fractionating said feedstock under effective fractionation conditions in the presence of a solvent for lignin, carbonic acid, and water, to produce a liquor containing hemicellulose, cellulose-rich solids, and lignin;
  - (c) substantially removing said cellulose-rich solids from said liquor;
  - (d) hydrolyzing said hemicellulose contained in said liquor, under effective hydrolysis conditions, to produce hemicellulosic monomers;
  - (e) optionally hydrolyzing at least some of said cellulose-rich solids to produce glucose;

- (f) optionally recovering at least some of said cellulose-rich solids as a cellulose product;
- (g) recovering said hemicellulosic monomers, and optionally said glucose if step (e) is conducted, to produce fermentable sugars; and
- (h) recovering said lignin.

3. A process for fractionating cellulosic biomass into cellulose, hemicellulose, and lignin, said process comprising:

- (a) providing a feedstock comprising lignocellulosic biomass;
- (b) in a digester, fractionating said feedstock under effective fractionation conditions in the presence of a solvent for lignin, water, and a carbonate dianion or salt thereof and/or a bicarbonate anion or salt thereof, to produce a liquor containing hemicellulose, cellulose-rich solids, and lignin;
- (c) substantially removing said cellulose-rich solids from said liquor;
- (d) hydrolyzing said hemicellulose contained in said liquor, under effective hydrolysis conditions, to produce hemicellulosic monomers;
- (e) optionally hydrolyzing at least some of said cellulose-rich solids to produce glucose;
- (f) optionally recovering at least some of said cellulose-rich solids as a cellulose product;
- (g) recovering said hemicellulosic monomers, and optionally said glucose if step (e) is conducted, to produce fermentable sugars; and
- (h) recovering said lignin.

4. The process of any one of claims 1 to 3, said process further comprising fermenting said fermentable sugars to a fermentation product and CO<sub>2</sub>, wherein step (b) utilizes said CO<sub>2</sub> in free form, dissolved form, or reacted form.

5. The process of claim 4, wherein said fermentation product is ethanol, and wherein step (b) utilizes recycled ethanol as said solvent for lignin, as well as said CO<sub>2</sub> in free form, dissolved form, or reacted form.

6. The process of any one of claims 1 to 3, said process further comprising introducing an acid to step (b), step (d), and/or step (e), wherein said acid is not derived from CO<sub>2</sub>.
7. The process of claim 6, wherein said acid is a sulfur-containing acid.
8. The process of any one of claims 1 to 3, wherein said cellulose-rich solids are further extracted with an additional acid after removing said cellulose-rich solids from said liquor.
9. The process of any one of claims 1 to 3, said process further comprising introducing an enzyme to step (b), step (d), and/or step (e).
10. The process of any one of claims 1 to 3, wherein a portion of said lignin recovered in step (h) is a lignocarbonate.

FIG. 1

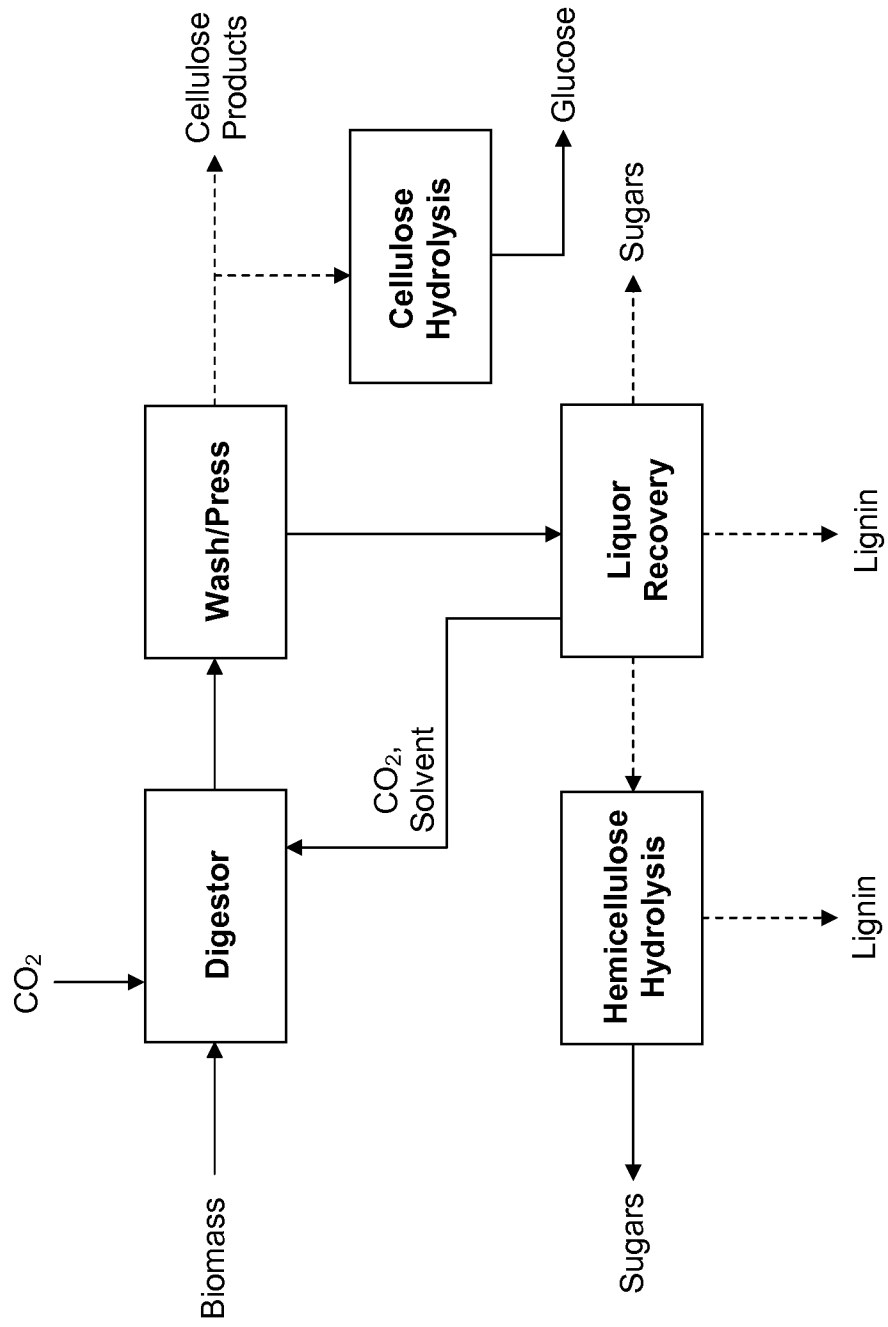
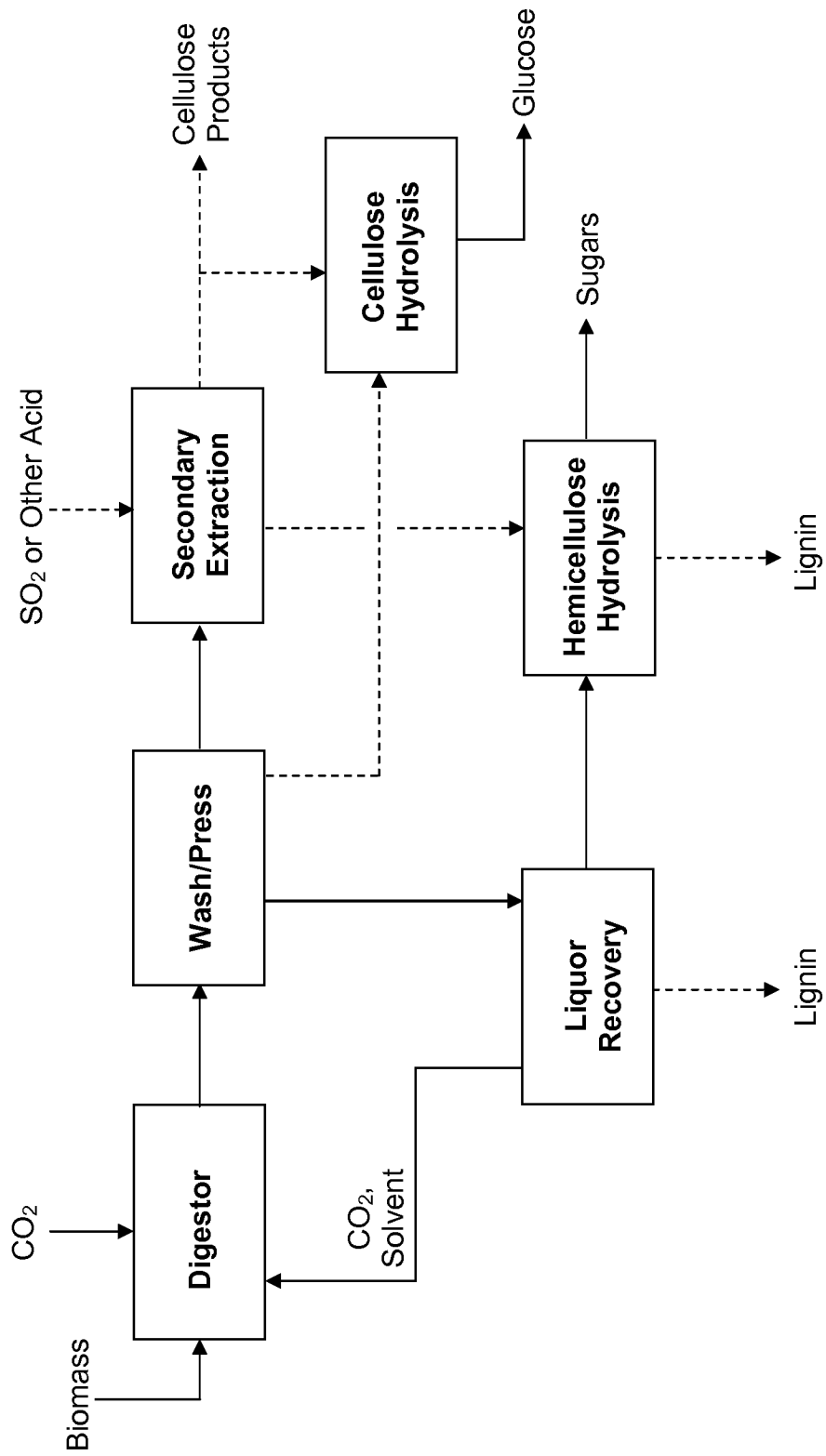

FIG. 2



## INTERNATIONAL SEARCH REPORT

International application No.

PCT/US 2013/076384

A. CLASSIFICATION OF SUBJECT MATTER		<i>C08H 8/00 (2010.01)</i> <i>D21C 3/04 (2006.01)</i> <i>D21C 3/22 (2006.01)</i> <i>D21C 3/20 (2006.01)</i> <i>C08B 1/00 (2006.01)</i> <i>C08B 37/14 (2006.01)</i>
According to International Patent Classification (IPC) or to both national classification and IPC		
B. FIELDS SEARCHED		
Minimum documentation searched (classification system followed by classification symbols)		
D21C 3/00, 3/04, 3/06, 3/20, 3/22, 5/00, C08B 1/00, 37/14, C08H 8/00		
Documentation searched other than minimum documentation to the extent that such documents are included in the fields searched		
Electronic data base consulted during the international search (name of data base and, where practicable, search terms used)		
PatSearch (RUPTO internal), USPTO, PAJ, Esp@cenet, DWPI, EAPATIS, PATENTSCOPE, Information Retrieval System of FIPS		
C. DOCUMENTS CONSIDERED TO BE RELEVANT		
Category*	Citation of document, with indication, where appropriate, of the relevant passages	Relevant to claim No.
Y	WO 2011/091044 A1 (SRIYA INNOVATIONS, INC et al.) 28.07.2011, claims	1-10
Y	WO 1998/014270 A1 (MIDWEST RESEARCH INSTITUTE) 09.04.1998, claims	1-10
Y	WO 2009/114843 A1 (VIRGINIA TECH INTELLECTUAL PROPERTIES, INC. et al.) 17.09.2009, claims	1-10
Y	WO 1999/034021 A1 (XYROFIN OY) 08.07.1999, claims	9
A	RU 2135665 C1 (IMPCO-VOEST-ALPINE PULPING TECHNOLOGIES GMBH) 27.08.1999	1-10
<input type="checkbox"/> Further documents are listed in the continuation of Box C. <input type="checkbox"/> See patent family annex.		
* Special categories of cited documents:		
"A"	document defining the general state of the art which is not considered to be of particular relevance	"T" later document published after the international filing date or priority date and not in conflict with the application but cited to understand the principle or theory underlying the invention
"E"	earlier document but published on or after the international filing date	"X" document of particular relevance; the claimed invention cannot be considered novel or cannot be considered to involve an inventive step when the document is taken alone
"L"	document which may throw doubts on priority claim(s) or which is cited to establish the publication date of another citation or other special reason (as specified)	"Y" document of particular relevance; the claimed invention cannot be considered to involve an inventive step when the document is combined with one or more other such documents, such combination being obvious to a person skilled in the art
"O"	document referring to an oral disclosure, use, exhibition or other means	"&" document member of the same patent family
"P"	document published prior to the international filing date but later than the priority date claimed	
Date of the actual completion of the international search		Date of mailing of the international search report
17 April 2014 (17.04.2014)		15 May 2014 (15.05.2014)
Name and mailing address of the ISA/ FIPS Russia, 123995, Moscow, G-59, GSP-5, Berezhkovskaya nab., 30-1		Authorized officer  I. Devnina
Facsimile No. +7 (499) 243-33-37		Telephone No. 499-240-25-91