

W. KOPS.
BUCKLE.

APPLICATION FILED JAN. 11, 1915.

1,148,972.

Patented Aug. 3, 1915.

Fig. 1.

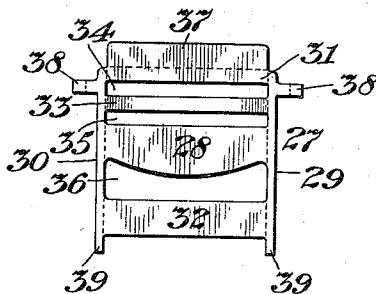

Fig. 2.

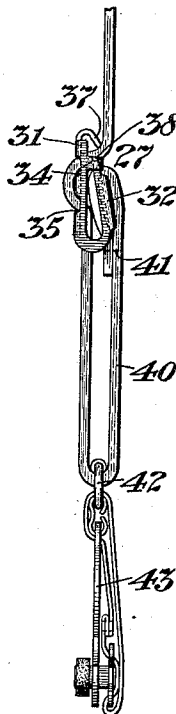

Fig. 3.

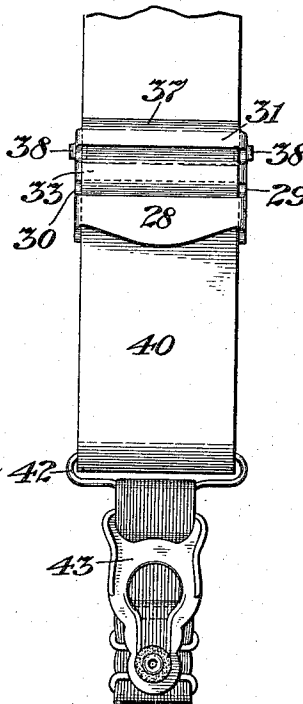
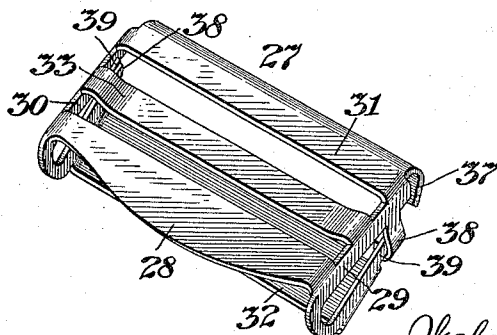

Fig. 4.



Witnesses;
Chas. Clagitt
Geo. T. Linckney

Inventor,
Waldemar Kops
By Serrell & Son
his Attorneys.

UNITED STATES PATENT OFFICE.

WALDEMAR KOPS, OF NEW YORK, N. Y., ASSIGNOR TO KOPS BROS., OF NEW YORK, N. Y.,
A FIRM.

BUCKLE.

1,148,972.

Specification of Letters Patent.

Patented Aug. 3, 1915.

Substitute for application Serial No. 701,714, filed June 5, 1912. This application filed January 11, 1915.
Serial No. 1,720.

To all whom it may concern:

Be it known that I, WALDEMAR KOPS, a citizen of the United States of America, residing at the borough of Manhattan, city, county, and State of New York, have invented a new and useful Improvement in Buckles, of which the following is a specification.

My present invention relates to an improvement in buckles for connecting parts of a webbing or similar flexible material commonly employed in hose supporters, suspenders, belts and various other analogous articles, in which an adjustable clamp is employed, and the object of my invention is the provision of a simple, easily and cheaply constructed buckle and one in which the grip is effected frictionally in contradistinction to a positive grip being made by teeth or serrated edges of the gripping members of buckles as commonly constructed.

In carrying out my invention, the improved buckle is preferably stamped up from a single or integral piece of sheet metal or other similar or suitable material, and the blank is so formed as to provide the buckle with obverse and reverse side members and end members at the extremities of the side members, the end members being turned over on themselves so that their corners come in close proximity to one another and the reverse side members assume a position behind the obverse side members. The elastic webbing or other material is looped over a reverse side member, and in the use of the buckle, the frictional grip upon the material is obtained by contact with the edge of an inturned portion extending from an obverse side member, as will be hereinafter more particularly described.

In order to secure a positive grip between the extremities of the end members, I also provide these members, with lugs or similar devices, which, after the end members are bent or turned into position, as herein described, are made to engage the opposite extremities of the end members to positively connect the same.

Figure 1 is a plan of a blank, for forming a buckle made in accordance with my present invention. Fig. 2 is a side elevation, illustrating the use of this buckle. Fig. 3 is a front elevation of the same, and Fig. 4

is a perspective view illustrating my improved buckle.

Referring to the drawing, it will be seen that I may also form my improved buckle from a blank indicated at 27. This blank is stamped up from sheet metal, caused to be provided with an obverse side member 28. The end members 29 and 30 are integral with each other, as are also the reverse side member 32 and the obverse side members 31 and 33, which latter is intermediate of the obverse side members 28 and 31. This structure makes provision for an aperture 34 between the members 31 and 33, an aperture 35 between the members 28 and 33, and an aperture 36 between the obverse side member 28 and the reverse side member 32. Extending from the end member 31 is an end portion 37, and adjacent to this end of the buckle, the end members 29 and 30 are provided with lugs 38, and at the opposite ends the end members 29 and 30 are provided with ears or extensions 39.

In shaping this blank, the end members 29 and 30 are bent into a U-shape form, so that the extensions or ears 39 are caused to assume a position either in contact with or closely adjacent to the opposite ends of the end members, and, in this position, the lugs 38 are turned over and caused to engage the extensions, or ears 39, to secure the parts together permanently, in order to prevent the separation thereof by strains to which the buckle is subjected in use, or from other causes.

It will be understood that other equivalent devices may be employed for suitably connecting the adjacent ends of the end members 29 and 30 without departing from the nature and spirit of my invention.

In the use of this form of the buckle, as shown in Figs. 2 and 3, a webbing 40 may be employed for a hose supporter, for example, one end of this webbing is threaded through the aperture 36, a loop formed in the end of the web and the parts thereof secured together by sewing indicated by dotted line 41. The webbing is then passed through an eye 42 of a garment clasp 43, after which the web is threaded through the aperture 35 from the inside outwardly, then through the aperture 34 from the outside of the buckle inwardly, and the surface of the web, in the use of the device, contacts with

the edge of the end portion 37, which is curved inwardly in such a manner that the frictional contact between the edge of this end portion and the web in use maintains
5 the web in position in the buckle.

I claim as my invention—

10 A buckle stamped up from a blank of sheet metal and comprising an obverse side member, a reverse side member, end members connecting the said obverse and reverse side members and being bent at right angles thereto and also bent into U-form,

the said obverse side member having a portion extending over the reverse side member, the edge of the portion providing a gripping edge for the buckle, and means for securing together the extremities of the U-form end members. 15

Signed by me this 5th day of December, 1914.

WALDEMAR KOPS.

Witnesses:

ERNST NEUMANN,
ELKAN A. HACKEY.

Copies of this patent may be obtained for five cents each, by addressing the "Commissioner of Patents, Washington, D. C."