

*J. Lemman.*  
*Making Chair Backs & Seats.*  
*N<sup>o</sup> 93,893.                      Patented Aug. 17, 1865.*

*Fig. 1.*

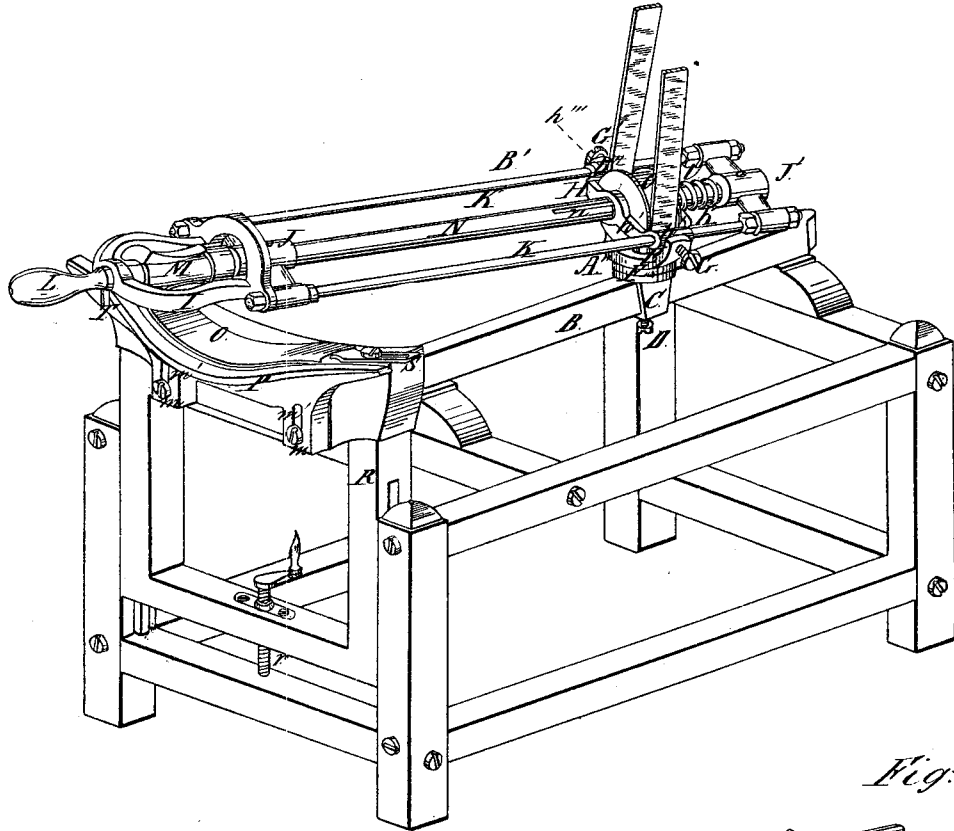

*Fig. 2.*

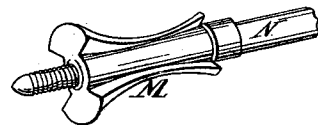

*Fig. 3.*

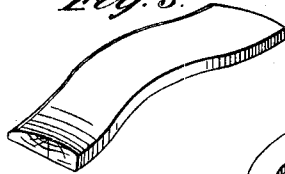

*Fig. 4.*

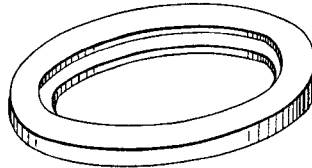

*Witnesses*  
*W. B. Philipp*  
*C. K. Pickles.*

*Inventor*  
*John Lemman*  
*By F. Millward*  
*attorney*

# United States Patent Office.

JOHN LEMMAN, OF CINCINNATI, OHIO.

Letters Patent No. 93,893, dated August 17, 1869.

## IMPROVEMENT IN MACHINE FOR MOULDING CHAIR-BACKS.

The Schedule referred to in these Letters Patent and making part of the same.

To all whom it may concern:

Be it known that I, JOHN LEMMAN, of Cincinnati, Hamilton county, State of Ohio, have invented a certain new and useful Machine for Moulding Chair-Backs, Picture-Frames, &c.; and I do hereby declare the following to be a sufficiently full, clear, and exact description thereof, to enable one skilled in the art to which my invention appertains, to make and use it, reference being had to the accompanying drawings, making part of this specification.

My invention consists, in the first part, in the provision, in connection with a fixed "form" or "template," or guide, of a revolving cutter, which is journalled in such a manner, and so connected to the frame of the machine, that it is capable of swinging bodily round on a fixed centre, is also adapted to be elevated and depressed, and worked at varying distances from the point on which it swivels, the fixed "form" serving to govern these movements and guide the cutter in moulding the work to the prescribed shape.

The second part of my invention consists in the provision of a coiled spring, or its equivalent, attached between the end of the cutter-frame and the frame of the machine, which serves in connection with a projecting lug or stud from the cutter-frame, to keep the cutter steady, and forcibly compel it to traverse the line prescribed for it by the "form."

The third part of my invention consists of certain devices for adjusting the position of the "form," and the work with relation to the axis of the cutter-spindle.

In the accompanying drawings—

Figure 1 is a perspective view of a machine embodying my invention.

Figure 2 is a view of a cutter specially designed for moulding chair-backs.

Figure 3 is a view of a chair-back as completed by the machine.

Figure 4 represents an oval picture-frame, for the moulding of which the machine is well adapted. The application of the machine for this class of work will be hereafter explained.

Fig. 1 represents the machine as applied to the moulding of chair-backs.

To the frame A, a universal joint, A', is attached, which is adjustable along the bar B, this universal adjustable joint consisting of socket C, tightening-screw D, swivel-pin E, jaw F, swivel-pins G G', and swivelling journal-box H, the latter having two bearings, *h h'*, in which the cutter-spindle revolves, and two sockets, *h'' h'''*, through which the cutter-frame slides.

The cutter-frame B', which carries the cutter and cutter-spindle, consists of the guard I, which surrounds the cutter-head, cross-heads J J', and side-

rods K K', the guard I being provided with a handle, L, by which the operator manipulates the cutter over the work.

In addition to the journals *h h'*, the cutter-spindle is journalled in the cross-heads J J', and in the guard I.

M is the cutter, and N, the spindle, to which it is securely attached.

O is the driving-pulley of the cutter.

It is located between the bearings *h h'*, and is provided with a feather, which fits the groove *n* in the spindle.

The groove-and-feather device permits the spindle to slide through its driving-pulley, the side-rods at the same time sliding through the sockets *h'' h'''*.

P is the "form" or "template," which is so shaped that it will properly govern the cutter M in moulding the work.

It is adjustable in height by means of screws *m m* and slots *m' m'*.

The work Q, which represents a chair-back, is secured to the sliding frame R by means of clamps S, this being adjustable in height by means of screw *r*, substantially as shown.

A lug or stud, T, projects from the under side of the guard I, which is designed to engage with and follow the curves of the form.

It is kept well up against the form, and forcibly compelled to confine itself to the path prescribed for it, by means of the spring U, which fits over the cutter-spindle, and between the bearing *h'* and the end of the cutter-frame.

This device also serves to hold the cutter steady.

The cutter M is constructed substantially in the manner shown in fig. 2, and is adapted to cut equally well in either direction of rotation. It is never permitted to cut against the grain of the wood, but by means of the well-known device for reversal used in lathes, &c., the direction of rotation can be at any time reversed, in order to cut "with the grain."

The machine is arranged to cut varying thicknesses of chair-backs, by the vertical adjustment of the "form," and the angle at which it is cut can be varied by the elevation or depression of the sliding frame R.

The machine is adapted for the manufacture of picture-frames, by a proper disposition of the form and work, the frame of the cutter, when required, being capable, when the driving-mechanism is specially designed for it, of sweeping an entire circle.

The form used for picture-frames, &c., can be so shaped as to produce a waving moulding on the frame.

I claim herein as new, and of my invention—

1. The sliding and swivelling cutter-frame A' B',

and cutter-spindle M N, constructed and operating substantially in the manner described, in combination with the "form" P, for the purpose specified.

2. The coiled spring U, in combination with the projection T of the cutter-frame, when constructed and arranged substantially in the manner and for the purpose explained.

3. The arrangement of the sliding frame R, form P, made adjustable by screws *m m* and slots *m' m'*, cut-

ter-frame A' B', spindle M N, spring U, and projection T, all being constructed and arranged to operate as described.

In testimony of which invention, I hereunto set my hand.

JOHN LEMMAN.

Witnesses:

THEO. H. JAMES,  
C. K. PICKLES.