

**(12) STANDARD PATENT**  
**(19) AUSTRALIAN PATENT OFFICE**

(11) Application No. **AU 2010201635 B2**

(54) Title  
**Tap hole plug gun for metallurgical furnace**

(51) International Patent Classification(s)  
**C21B 7/12 (2006.01)**

(21) Application No: **2010201635** (22) Date of Filing: **2010.04.22**

(30) Priority Data

(31) Number	(32) Date	(33) Country
<b>09008106.8</b>	<b>2009.06.20</b>	<b>EP</b>

(43) Publication Date: **2011.01.13**

(43) Publication Journal Date: **2011.01.13**

(44) Accepted Journal Date: **2011.08.18**

(71) Applicant(s)  
**TMT Tapping-Measuring-Technology GmbH**

(72) Inventor(s)  
**Vincent, John Paul;Goosen, Johannes Jacobus**

(74) Agent / Attorney  
**Griffith Hack, Level 29, Northpoint 100 Miller Street, North Sydney, NSW, 2060**

(56) Related Art  
**US 1555711**

ABSTRACT

Title: Tap hole plug gun for metallurgical furnaces

The invention relates to a tap hole plug gun (1) for metallurgical furnaces, having a pressure cylinder (2) for receiving the plugging compound, which has a closable filling opening (3) for the plugging compound, and having a plugging piston for pressing the plugging compound out from a mouthpiece (6) of the pressure cylinder (2) pressed against the tap hole of a furnace. The pivotable safety flap (4) for closing the filling opening (3) of the pressure cylinder (2) for the plugging compound is equipped with a stop (8), which is pivoted into the cylinder chamber (9) of the pressure cylinder (2) upon opening of the flap (8) to decelerate an unintentional forward stroke of the plugging piston for pre-compression and expulsion of the plugging compound, and is pivoted out of the cylinder chamber (9) upon closing of the safety flap (4).

(Figure 1)

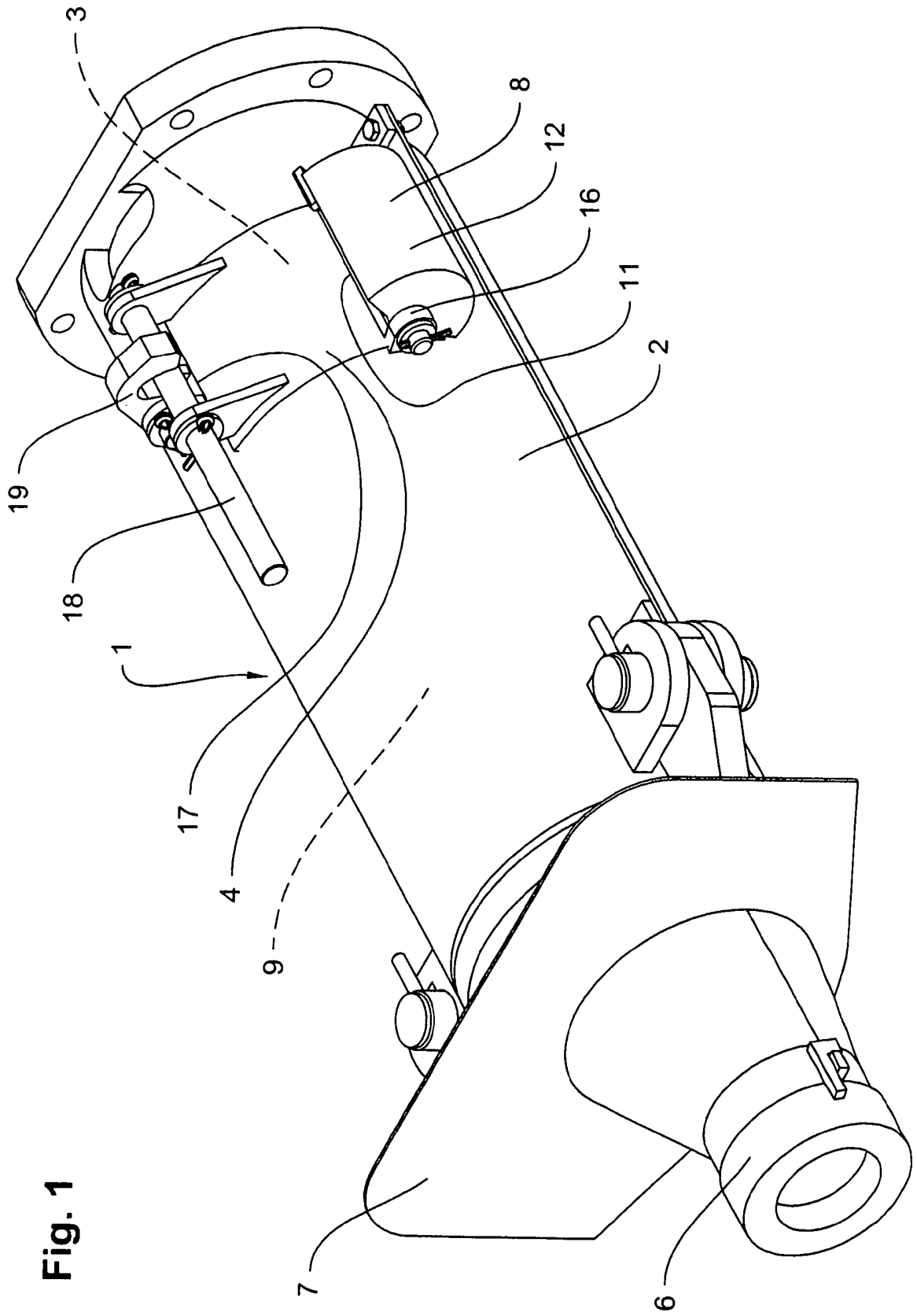

Fig. 1

2010201635 22 Apr 2010

AUSTRALIA

Patents Act 1990

**COMPLETE SPECIFICATION**

**Standard Patent**

**Applicant(s):**

*TMT Tapping-Measuring-Technology GmbH*

**Invention Title:**

*TAP HOLE PLUG GUN FOR METALLURGICAL FURNACE*

The following statement is a full description of this invention,  
including the best method for performing it known to me/us:

- 1A -

## TAP HOLE PLUG GUN FOR METALLURGICAL FURNACE

### Technical Field

The invention relates to a tap hole plug gun for metallurgical furnaces, having a pressure cylinder for receiving the plugging compound, which has a closable filling opening for the plugging compound, and having a plugging piston for pressing out the plugging compound from a mouthpiece of the pressure cylinder which is pressed against the tap hole of a furnace.

### Background Art

The tap hole plug guns of this type described in DE 30 07 072 C2 are used for closing the tap openings of reducing or melting furnaces, e.g., blast furnaces for obtaining crude iron and low shaft furnaces for melting nonferrous metals, ferrous alloys, etc. In the plugging work step, the plug gun is pressed against the furnace facing with a great force using a pivot device, the contact pressure force of the plug on being maintained until the elastic plugging compound pressed through the plug gun into the tap hole opening of the furnace has hardened.

In the known tap hole plug guns, the danger exists during the manual filling of the plugging compound into the cylinder chamber of the pressure cylinder that due to incorrect operation of the smelter or a coworker, the plugging piston will execute an unintentional forward stroke in the direction toward the mouthpiece of the pressure cylinder for the pre-compression and expulsion of the plugging compound and thus the smelter could suffer severe hand and arm injuries.

Preferably the operational reliability of the tap hole plug gun according to the species will be improved.

It is to be understood that, if any prior art publication is referred to herein, such reference does not constitute an admission that the publication forms a part of the

2010201635 11 Jul 2011

- 2 -

common general knowledge in the art, in Australia or any other country.

#### Summary of the Disclosure

The stop integrated in the safety flap for closing and opening the filling opening for the plugging compound of the pressure cylinder of the tap hole plug gun, which is automatically pivoted into the cylinder chamber of the pressure cylinder upon opening of the safety flap to decelerate an unintentional pre-compression or expulsion stroke of the plugging piston, represents a simple and cost-effective constructive measure for improving operational reliability of the tap hole plug gun.

#### Brief Description of the Drawings

The invention is explained hereafter on the basis of the figures of the drawing; in the figures:

Figure 1 shows a perspective illustration of a tap hole plug gun,

Figure 2 shows a side view of the tap hole plug gun,

Figure 3 shows an enlarged cross-sectional illustration of the tap hole plug gun along section line III-III of Figure 2 with the closed position of the safety flap for the plugging compound filling opening, and

Figure 4 shows an enlarged cross-sectional illustration of the tap hole plug gun corresponding to Figure 3 with the open position of the safety flap.

#### Detailed Description of Specific Embodiments

The tap hole plug gun 1 has a pressure cylinder 2 having a safety flap 4, which is pivotable in the arrow direction a

2010201635 11 Jul 2011

2010201635 22 Apr 2010

out of the closed position 4a into the open position 4b and vice versa to open and close the filling opening 3 of the pressure cylinder 2 for the plugging compound, a plugging piston 5 for pressing the plugging compound out of a mouthpiece 6, which is pressed against the tap hole of a furnace, an electrohydraulic drive (not shown), for example, for the plugging piston 5, and a protective shield 7, which is situated on the mouthpiece 6, against the effect of heat and melted material exiting from the tap hole of a furnace.

The pivotable safety flap 4 for closing the filling opening 3 of the pressure cylinder 2 for the plugging compound is equipped with a stop 8, which, upon opening of the flap 4 by pivoting it in the arrow direction a into the open position 4b, is pivoted into the cylinder chamber 9 of the pressure cylinder 2 to decelerate an unintentional forward stroke of the plugging piston 5 in the arrow direction c for the pre-compression and expulsion of the plugging compound, and upon closing of the safety flap 4 by pivoting it in the arrow direction b into the closed position 4a, is pivoted out of the cylinder chamber 9.

The safety flap 4 is implemented as curved corresponding to the jacket 10 of the pressure cylinder 2 and engages positively in the filling opening 3 of the pressure cylinder 2 in the closed position 4a.

A roller segment 12, which is outwardly directed in the closed position 4a of the safety flap, is situated on one transverse side of 11 of the safety flap 4 and is pivoted into the cylinder chamber 9 of the pressure cylinder 2 in the open position 4b of this safety flap 4 and forms the stop 8 for the plugging piston 5.

The roller segment 12 has a concentric bearing hole 13, for example, for the pivot axis 15 of the safety flap 4, which

- 4 -

is oriented parallel to the central axis 14-14 of the pressure cylinder 2 for receiving the plugging compound, and the pivot axis 15 is mounted fixed in bearing eyes 16 on the jacket 10 of the pressure cylinder 2.

A rod-shaped handle 18, which is oriented parallel to the central axis 14-14 of the pressure cylinder 2, is attached in the area of the other transverse side 17 of the safety flap 4, which is lockable in the closed position 4b of the safety flap 4 using a hook 19 linked on the jacket 10 of the pressure cylinder 2.

In the claims which follow and in the preceding description of the invention, except where the context requires otherwise due to express language or necessary implication, the word "comprise" or variations such as "comprises" or "comprising" is used in an inclusive sense, i.e. to specify the presence of the stated features but not to preclude the presence or addition of further features in various embodiments of the invention.

2010201635 11 Jul 2011

- 5 -

CLAIMS

1. A tap hole plug gun for metallurgical furnaces, having a pressure cylinder for receiving the plugging compound, which has a closable filling opening for the plugging compound, and having a plugging piston for pressing out the plugging compound from a mouthpiece of the pressure cylinder, which is pressed against the tap hole of a furnace, characterized by a pivotable safety flap for closing the filling opening of the pressure cylinder for the plugging compound, the safety flap having a stop (8) for the plugging piston, which is pivoted into the cylinder chamber of the pressure cylinder upon opening of the flap to decelerate an unintentional forward stroke of the plugging piston for pre-compression and expulsion of the plugging compound, and is pivoted out of the cylinder chamber upon closing of the safety flap.
2. The tap hole plug gun according to Claim 1, characterized in that, on one transverse side of the safety flap, which is curved corresponding to the jacket of the pressure cylinder, and engages positively in the filling opening of the pressure cylinder for the plugging compound in the closed position, a roller segment, which is directed outward in the closed position of the safety flap, is situated, which is pivoted into the cylinder chamber of the pressure cylinder in the open position of the safety flap and forms the stop for the plugging piston, and the roller segment has a bearing hole for the pivot axis of the safety flap, which is oriented parallel to the central axis of the pressure cylinder for the plugging compound, and which is mounted fixed in bearing eyes on the jacket (10) of the pressure cylinder.
3. The tap hole plug gun according to Claim 1 or 2, characterized by a handle, which is attached to the

2010201635 11 Jul 2011

-6-

safety flap in the area of the other transverse side of the safety flap, and is oriented parallel to the central axis of the pressure cylinder, and a hook, which is linked on the jacket of the pressure cylinder and engages on the handle, for locking the safety flap in its closed position.

4. A tap hole plug gun substantially as hereinbefore described, with reference to the accompanying Figures.

2010201635 11 Jul 2011

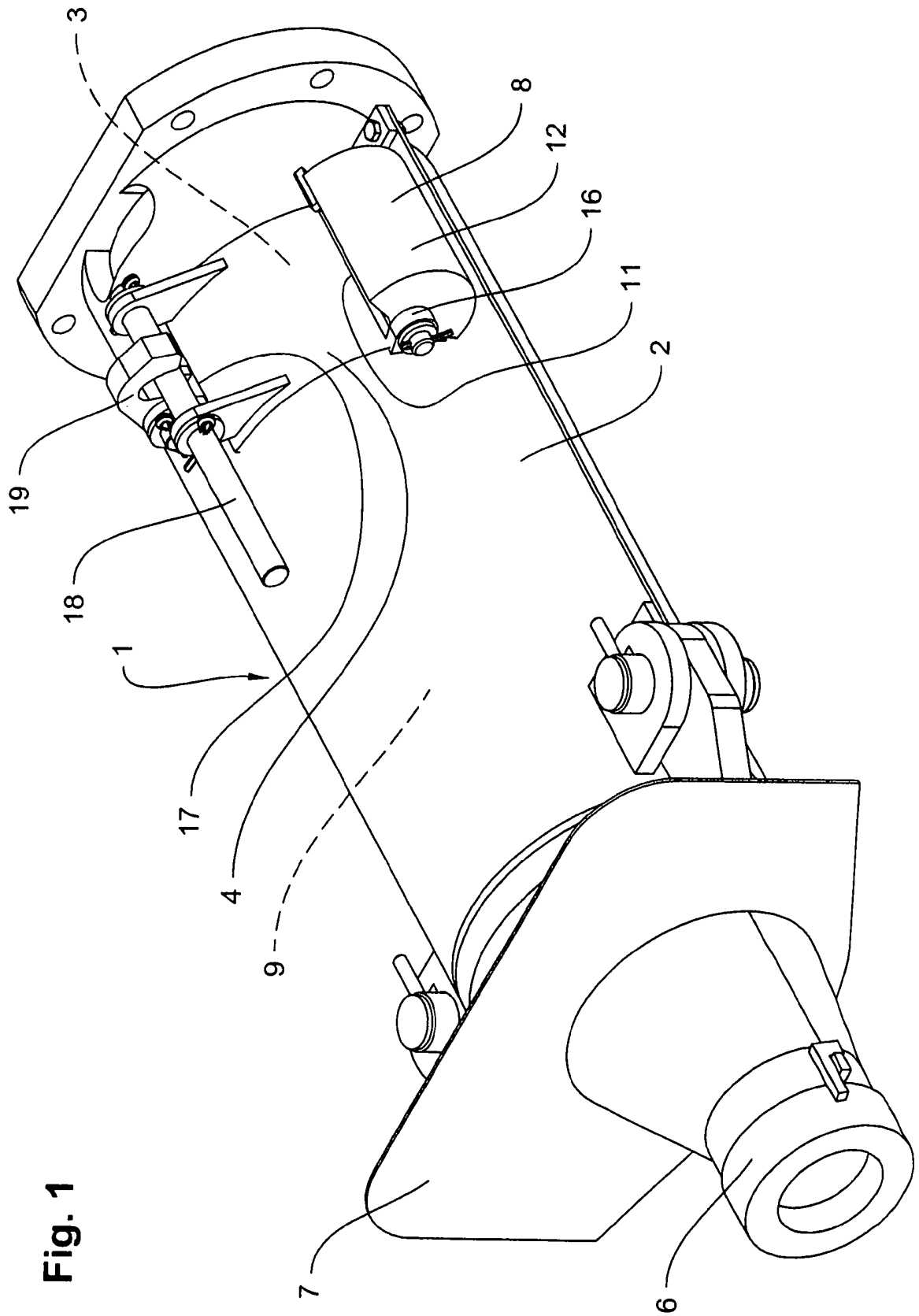
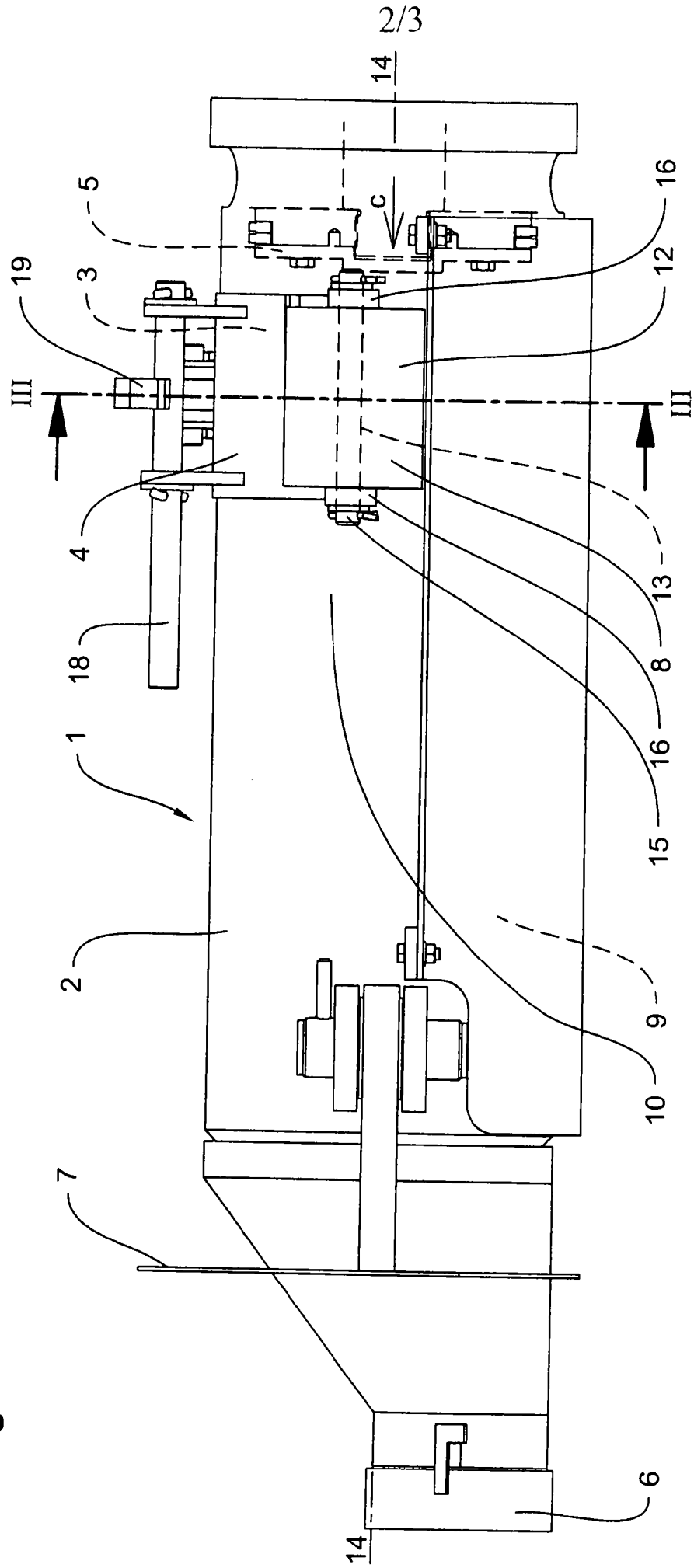
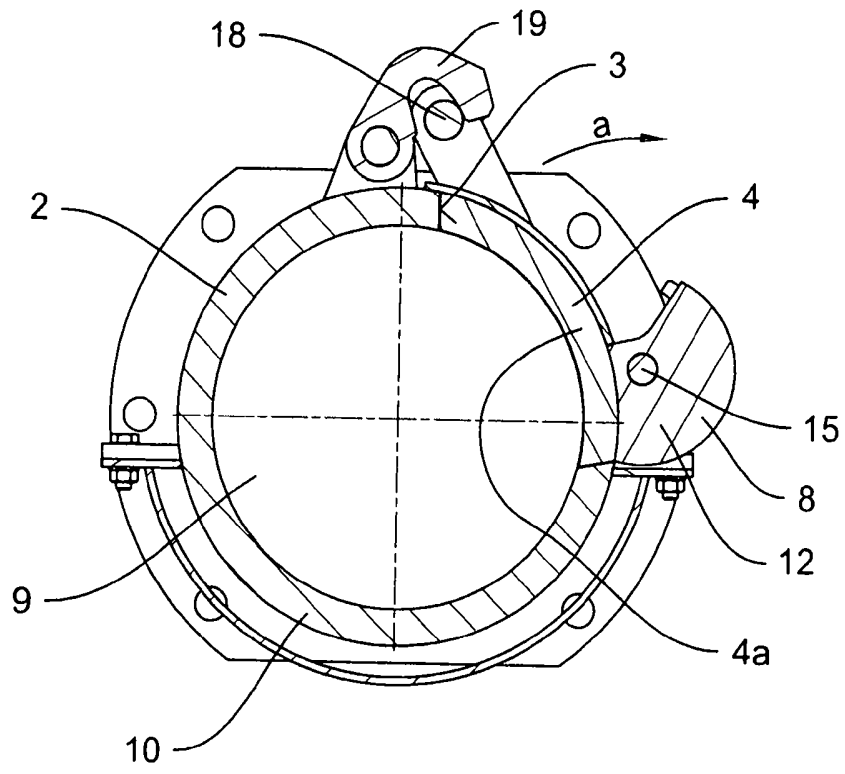

Fig. 1

Fig. 2



**Fig. 3**



**Fig. 4**

