

(19) World Intellectual Property Organization
International Bureau



(43) International Publication Date
23 August 2001 (23.08.2001)

PCT

(10) International Publication Number
WO 01/61354 A1

(51) International Patent Classification⁷: G01N 33/566

(21) International Application Number: PCT/US01/05118

(22) International Filing Date: 16 February 2001 (16.02.2001)

(25) Filing Language: English

(26) Publication Language: English

(30) Priority Data:
09/507,299 18 February 2000 (18.02.2000) US
09/507,300 18 February 2000 (18.02.2000) US
60/203,082 9 May 2000 (09.05.2000) US

(71) Applicant: ASPIRA BIOSYSTEMS, INC. [US/US]; 213 East Grand Avenue, South San Francisco, CA 94080 (US).

(72) Inventor: HUANG, Chin-Shiou; 1501 Hillsdale Boulevard, #210, San Mateo, CA 94402 (US).

(74) Agents: ABRAMS, Samuel, B. et al.; Pennie & Edmonds LLP, 1155 Avenue of the Americas, New York, NY 10036 (US).

(81) Designated States (*national*): AE, AG, AL, AM, AT, AU, AZ, BA, BB, BG, BR, BY, BZ, CA, CH, CN, CR, CU, CZ, DE, DK, DM, DZ, EE, ES, FI, GB, GD, GE, GH, GM, HR, HU, ID, IL, IN, IS, JP, KE, KG, KP, KR, KZ, LC, LK, LR, LS, LT, LU, LV, MA, MD, MG, MK, MN, MW, MX, MZ, NO, NZ, PL, PT, RO, RU, SD, SE, SG, SI, SK, SL, TJ, TM, TR, TT, TZ, UA, UG, UZ, VN, YU, ZA, ZW.

(84) Designated States (*regional*): ARIPO patent (GH, GM, KE, LS, MW, MZ, SD, SL, SZ, TZ, UG, ZW), Eurasian patent (AM, AZ, BY, KG, KZ, MD, RU, TJ, TM), European patent (AT, BE, CH, CY, DE, DK, ES, FI, FR, GB, GR, IE, IT, LU, MC, NL, PT, SE, TR), OAPI patent (BF, BJ, CF, CG, CI, CM, GA, GN, GW, ML, MR, NE, SN, TD, TG).

Published:
— with international search report

For two-letter codes and other abbreviations, refer to the "Guidance Notes on Codes and Abbreviations" appearing at the beginning of each regular issue of the PCT Gazette.



WO 01/61354 A1

(54) Title: COMPOSITIONS AND METHODS FOR SURFACE IMPRINTING

(57) Abstract: The present invention provides surface imprint compositions useful for capturing, isolating, detecting, analyzing and/or quantifying molecules in a sample. The surface imprint compositions comprise a matrix material having imprint cavities of a template molecule or molecules imprinted thereon wherein a substantial number of the imprint cavities are located at or near the surface of the matrix material.

Compositions and Methods for Surface Imprinting

1. FIELD OF THE INVENTION

5 The present invention is directed to novel molecular surface imprints. Surface imprints comprise cavities that correspond in shape to the shape of a template molecule. A substantial number of the cavities are localized at the surface of the imprint and are oriented for efficient binding. The present invention is also directed to novel methods of making surface imprints. Surface localization and/or orientation provides a
10 greater fraction of cavities accessible for binding target molecules. Surface imprints made by this method form selective complexes with their target macromolecules. Arrays of surface imprints can be used to rapidly and inexpensively screen diverse samples.

2. BACKGROUND OF THE INVENTION

15 Conventional techniques of molecular imprinting have provided useful methods for the preparation of matrices that are capable of selectively capturing a target molecule. To prepare a molecular imprint, a matrix is formed around a template molecule. After the matrix has formed and the template molecule has been removed, the resulting molecular imprint can then be used to selectively capture the template molecule. As early
20 as 1949, a silica gel was created that selectively bound a dye (Dickey, 1949, Proc. Natl. Acad. Sci. USA 35:227-229). Recently, an imprint prepared with phenyl- α -D-mannopyranoside was sufficiently selective to resolve a racemic mixture of the saccharide (Wulff, 1998, Chemtech 28:19-26).

 Current methods form imprints of template molecules in organic polymers
25 (Wulff, 1998, supra). To create cavities of defined shape, polymerizable molecules are bound, covalently or noncovalently, to a template molecule (Wulff, 1998, supra). The resulting complex is then copolymerized in the presence of a large amount of a cross-linking reagent (Wulff, 1998, supra). The templates are then removed, leaving cavities having defined shapes (Wulff, 1998, supra). Molecular imprints made by such a technique
30 display selective binding for the template molecule. Molecular imprints have been used for chromatographic separation, immunoassays, chemosensors, and even catalysis (Wulff, 1998, supra).

 However, failings of conventional techniques limit the broad application of molecular imprints. According to a recent review, two issues "of great importance" that
35 limit the application of conventional molecular imprints are their limited capacity and the

heterogeneity of their imprint cavities (Cormack and Mosbach, 1999, *Reactive and Functional Polymers* 41:115-124). When used in an assay to capture the target molecule, it is believed that the random distribution of imprint cavities throughout a conventional molecular imprint limits the access of template molecules to the imprint cavities. The majority of cavities are localized in the interior of the molecular imprint and are less accessible to the template molecule than cavities that are localized at the surface of the imprint. In particular, large molecules that cannot penetrate the matrix material of a molecular imprint can bind only at surface cavities.

The binding capacity of conventional imprints is also reduced by the random orientation of their cavities. In forming a molecular imprint by conventional techniques, the template molecules are randomly oriented within the matrix. Thus, the corresponding molecular imprint cavities are also randomly oriented. If a particular orientation of an imprint cavity binds a target molecule more efficiently than other orientations, then only the fraction of cavities that are properly oriented will display efficient binding. The random orientation of the cavities, combined with their random distribution throughout the imprint, exacerbates the poor binding capacity of conventional molecular imprints.

Finally, conventional techniques suffer from leakage of the template molecule after formation of the imprint (Wulff, 1999, *supra*). When the imprint is formed, many template molecules are trapped deep within the imprint matrix. Trapped template molecules that are not removed may leak during the use of the molecular imprint. Leakage of the template molecule hinders application of conventional molecular imprints, particularly applications that involve minute amounts of a target molecule or dilute solutions. This shortcoming of conventional molecular imprints has limited their application in the pharmaceutical industry (Wulff, 1999, *supra*).

What is needed are novel molecular imprints that overcome the shortcomings of conventional molecular imprints. Novel molecular imprints with oriented and accessible binding cavities, and less leakage of the template molecule, will have improved capacity, specificity, and application.

3. SUMMARY OF THE INVENTION

These and other shortcomings in the art are overcome by the instant invention, which in one aspect provides surface imprint compositions useful for capturing, isolating, detecting, analyzing and/or quantifying molecules in a sample. Generally, the surface imprint compositions comprise a matrix material having an imprint cavity of a template molecule imprinted thereon. A substantial number of the imprint cavities are

localized at or near the surface of the matrix material. Moreover, a substantial number of the imprint cavities are oriented as compared with the imprint cavities of conventional molecular imprints. The surface imprint compositions of the invention display improved binding capacity and improved binding specificity compared to conventional molecular
5 imprints.

The surface imprints are useful for capturing, isolating, detecting, analyzing and quantifying potentially any target molecule. Structurally, the template molecule can be identical to or similar to the target molecule. In addition, the template molecule can correspond to a portion of a larger molecule. A surface imprint of a template molecule that
10 corresponds to a portion of a target molecule is particularly useful when the target molecule is a macromolecule. Template molecules that correspond to portions of macromolecules are described in detail in copending Application Serial No. 09/507,300 (attorney docket no. 10231-003-999), filed February 18, 2000, which is hereby incorporated by reference in its entirety.

15 A template molecule that corresponds to a target molecule or to a portion of a target molecule is most useful for capturing a known target molecule. However, as will be discussed more thoroughly below, an important aspect of the invention includes the ability to use the imprint compositions of the invention to isolate novel molecules from complex mixtures and/or samples. In this embodiment, a template molecule can have a structure that
20 does not necessarily correspond to a portion of any known molecule. For instance, a template molecule could be selected from a combinatorial library. For macromolecular targets, a template molecule could have a structure that corresponds to a portion of a consensus sequence derived from a family of macromolecules. Alternatively, a template molecule might also have a random structure. A molecular imprint of a template molecule
25 can bind a novel macromolecule if the template molecule corresponds to a portion of the novel macromolecule. An array of imprints of template molecules can be used to rapidly screen a mixture for novel macromolecules such as novel polypeptides. When the template molecules are biological polymers such as peptides, an array of imprints of the complete set of template molecules of a defined number of monomer amino acids can be used to capture
30 most or all of the polypeptides of a mixture. Template molecules that do not necessarily correspond to a portion of any known macromolecule are described in detail in copending Application Serial No. 09/507,300, supra.

Matrix materials that can comprise the imprint compositions of the invention include substances that are capable of undergoing a physical change from a fluid state to a
35 semi-solid or solid state. In the fluid state, matrix material molecules move easily amongst

themselves, and the material retains little or no definite form. A matrix material in the fluid state can be mixed with other compounds including template molecules. In the semi-solid or solid state, the matrix material is capable of defining and retaining cavities that complement the shape of template molecules dispersed or dissolved thereon. Non-limiting
5 examples of such matrix materials include heat sensitive hydrogels such as agarose, sol-gel materials, polymerizable monomers such as acrylamide, and mixtures of polymerizable monomers and cross-linking reagents.

The imprint compositions of the invention may take a variety of different forms. For example, they may be in the form of individual beads, disks, ellipses, or other
10 regular or irregular shapes (collectively referred to as "beads"), or in the form of sheets. Each bead or sheet may comprise imprints of a single template molecule, or they may comprise imprints of two or more different template molecules. In one embodiment, the imprint composition comprises imprints of a plurality of different template molecules that are arranged in an array or other pattern such that their positions within the array or pattern
15 correlate with their identities. Each position or address within the array may comprise an imprint of a single template molecule or imprints of a plurality of different template molecules, depending upon the application. Moreover, the entire array or pattern may comprise unique imprints, or may include redundancies, depending upon the application.

In another aspect, the invention provides methods of making surface imprint
20 compositions. In one embodiment, the compositions are prepared with template molecules that are immobilized on a solid support. Preferably, the template molecules are immobilized by way of covalent attachment. While not intending to be bound by any theory of operation, template molecules that are immobilized on a solid support yield surface imprints in which a substantial number of imprint cavities are localized at or near
25 the surface of the matrix material because the templates are not free to penetrate into the matrix material. Moreover, because the template molecules are immobilized at one point or end, the resultant imprint cavities tend to be oriented.

The solid support may have a single template molecule immobilized thereon, or a plurality of the same or different template molecules immobilized thereon. Solid
30 substrates having a plurality of template molecules immobilized thereon in a spatially defined pattern or array are particularly convenient for preparing surface imprint arrays. The immobilized template molecule(s) may be template molecules *per se*, or may compose a larger conjugate, as will be described in more detail below.

To make a surface imprint composition according to this embodiment of the
35 invention, a solid support having a template molecule immobilized thereon is contacted

with a matrix material. As previously discussed, the matrix material comprises a compound or mixture of compounds that is capable of undergoing a change of physical state such that the resultant product is a solid or semi-solid matrix that is capable of retaining shaped cavities. The matrix material is contacted with the immobilized template molecule under conditions in which the change of physical state is effected. Changing the physical state of the compound or mixture of compounds in the presence of the template molecule results in a solid or semisolid matrix having the template molecules entrapped therein. The solid support is then removed, yielding a solid or semisolid matrix comprising cavities that correspond in shape to the template molecules. This resultant product is a surface imprint composition. If the template molecules are not removed from the matrix material with the solid support, they may be removed by washing as described in more detail below. It will be appreciated that the solid support on which the template molecule is immobilized should have dimensions that are sufficiently large such that the solid support does not become embedded within the matrix material. Preferably, the solid support will have a planar, preferably flat, surface onto which the matrix material may be poured. Non-limiting examples of such preferred solid supports include glass slides or sheets, plastic sheets, films, etc. In instances where the matrix material comprises a polymer that retains its semisolid or solid state under heat, the solid support can comprise a heat sensitive compound such as those described above. After formation of the matrix, a heat-sensitive support can be removed from the matrix by application of heat to facilitate the removal of template molecules with minimal disruption of the matrix.

According to another embodiment, a surface imprint is prepared using a two-phase solvent system in which the template molecules are localized at the interface of the solvents. According to this method, a conjugate molecule comprising a template moiety and a tail moiety is prepared. The template moiety constitutes the template molecule that is to be imprinted. The tail moiety constitutes a molecule that mirrors the hydrophobicity of the template molecule. For instance, if the template molecule is hydrophobic, then the tail molecule is hydrophilic. Conversely, if the template molecule is hydrophilic, then the tail molecule is hydrophobic. The template molecule and tail molecule are linked together, optionally via a linker, to form the conjugate. Due to its amphipathic nature, the conjugate molecule partitions at the interface of a two-phase system.

To make the surface imprint, the conjugate and the matrix material (in its fluid state) are mixed with a solvent system that is capable of forming two phases. When mixed or dissolved in this system, the conjugate molecule partitions at the interface of the two-phase system, with the template moiety of the conjugate residing or partitioning in one

phase and the tail moiety of the conjugate residing or partitioning in the other phase. The matrix material is chosen so that it partitions into the same phase of the two-phase system as the template moiety. The mixture passively forms, or is induced to form, two phases, and conditions under which the matrix material changes from a fluid state to a semisolid or solid state are applied or effected. Changing the physical state of the matrix material in the presence of the template moiety results in a solid or semisolid matrix having the template moieties entrapped at the surface of the matrix. The tail moiety remains partitioned in the other phase of the two-phase system and does not become entrapped by the solid or semisolid matrix material. The conjugate molecules are then removed, yielding a solid or semisolid matrix comprising cavities located at or near the surface of the matrix material that correspond in shape to the template moieties. This resultant product is a surface imprint composition.

In still another aspect, the present invention provides methods of using the surface imprint compositions to capture, isolate, detect, analyze and/or quantify a molecule of interest in a sample. According to the method, a sample suspected of containing a molecule of interest is contacted with a surface imprint composition of the invention under conditions in which the molecule binds the imprint composition. The surface imprint-molecule complex may be optionally rinsed to remove unbound components of the sample. The molecule may be dissociated from the complex and isolated and/or quantified. Alternatively, the presence of the molecule may be detected, and/or its quantity determined, without dissociating it from the complex.

The methods can be used to capture molecules of known, partially known or unknown structure. In the former two embodiments, the imprint composition comprises an imprint of a template molecule that corresponds to a molecule of interest, or a portion thereof. In the latter embodiment, the imprint may comprise an imprint of a template molecule that corresponds to a conserved portion of a specific class of molecules, such as for example, a conserved portion of a receptor superfamily or family, or it may comprise an imprint of a template molecule with a novel or random structure. These latter imprint compositions can be used to capture and/or isolate novel members of known classes of molecules, or completely new types of molecules.

Molecules may be detected, captured, isolated, analyzed and/or quantified according to the methods of the invention singly, using a surface imprint composition specific for a particular molecule of interest, or alternatively, pluralities of different molecules can be captured simultaneously from a complex mixture using, for example, the

array or pattern imprint compositions described herein, for subsequent detection, isolation, analysis and/or quantification.

The methods and compositions of the invention provide significant advantages over currently available molecular imprinting technologies. Unlike known
5 imprinting techniques, the imprint cavities of the imprint compositions of the present invention are localized at the surface of the matrix material. Surface imprints are more sensitive than conventional imprints because surface imprints have a higher number of imprint cavities accessible at or near their surface for binding a target molecule. The greater
10 density of accessible imprint cavities also reduces the amount of nonspecific binding of the imprints, further increasing the sensitivity of the surface imprints of the present invention. In particular, the surface imprints of the invention have a significantly improved capacity for binding large molecules that cannot penetrate into the matrix material.

In addition, because the template molecules are oriented during the formation of the surface imprints, the surface imprints of the present invention have cavities
15 that are oriented, as compared with random cavities obtained using conventional techniques. Proper orientation of imprint cavities can improve the binding properties of a molecular imprint. In particular, when an imprint cavity corresponds to a portion of the molecule to be captured by the imprint, then the orientation of the cavity has a significant effect on its binding efficiency. For instance, referring to FIG. 1, if imprint cavities correspond to the
20 carboxy-terminal portion of polypeptide 2, then imprint cavity 4, which is accessible at its amino terminal end, will bind polypeptide 2 more effectively than imprint cavity 6, which is not accessible at its amino terminal end. Imprint cavity 6 might not bind macromolecule 2 at all. Surface imprints can be prepared according to the present invention so that almost every cavity is uniformly oriented to bind the target molecule.

25 Finally, the methods and compositions of the present application are also applicable to sensitive systems such as dilute mixtures of molecules where template leakage is a problem for conventional imprints. Compared to conventional molecular imprints that can entrap template molecules in internal cavities deep within their matrices, surface imprints retain far fewer template molecules within their solvent-accessible cavities.

30 The methods and surface imprint compositions of the invention have widespread applicability, ranging from the detection and/or isolation of specific molecules of interest from samples, to the capture, isolation, analysis and/or quantification of pluralities of molecules from complex mixtures for applications such as, for example, expression profiling, to the discovery of novel members of known classes of molecules
35 and/or completely new types of molecules altogether.

4. BRIEF DESCRIPTION OF THE FIGURES

FIG. 1 provides an illustration comparing a properly oriented imprint cavity with an improperly oriented imprint cavity of the same template molecule;

5 FIG. 2 provides an illustration comparing conventional molecular imprints with the surface imprint compositions of the invention;

FIG. 3A illustrates a conjugate molecule useful for preparing a surface imprint that can capture a target molecule;

10 FIG. 3B illustrates a method of preparing a surface imprint by imprinting immobilized template molecules;

FIG. 3C illustrates a method of preparing a surface imprint composition of the invention utilizing a two-phase system;

FIG. 4A illustrates a one-dimensional surface imprint array;

15 FIG. 4B illustrates a two-dimensional array of surface imprint beads distributed on a substrate;

FIG. 4C illustrates a cross-sectional view of an embodiment of a surface imprint array;

FIG. 5 illustrates the capture of a plurality of molecules with a surface imprint array;

20 FIG. 6 provides an SDS-PAGE analysis of a capture and isolation experiment performed with an acrylamide surface imprint composition of the present invention;

25 FIG. 7 provides an SDS-PAGE analysis of two experiments capturing and isolating cytochrome c from a mixture of proteins and from a cell lysate with surface imprint compositions of the present invention;

FIG. 8 provides an SDS-PAGE analysis of an experiment capturing and isolating myoglobin with an acrylamide surface imprint composition of the present invention; and

30 FIG. 9 provides an SDS-PAGE analysis of an experiment capturing and isolating trypsin inhibitor with an acrylamide surface imprint composition of the present invention.

5. DETAILED DESCRIPTION OF THE INVENTION

35 Current molecular imprints lack ideal binding specificity and capacity. The specificity and capacity of current molecular imprints are impaired by the poor accessibility

of many of their cavities and by the heterogeneity of those cavities. In addition, current molecular imprints suffer from constant leakage of template molecules.

The present invention provides compositions and methods that overcome these and other limitations of molecular imprinting. The invention is based, in part, on the Applicant's discovery that molecular imprints in which a substantial number or fraction of cavities are oriented and localized at or near the surface of the matrix material can be prepared by novel methods. The surface imprints of the present invention have cavities that are more accessible than those of prior imprints and that are properly oriented for binding a target molecule. Because the surface imprints internally trap fewer template molecules, the surface imprints compositions of the invention also exhibit less template leakage during use than conventional molecular imprints.

15

20

25

30

35

5.1 Abbreviations

As used herein, the abbreviations for the genetically encoded L-enantiomeric amino acids are conventional and are as follows:

	Amino Acid	One-Letter Symbol	Common Abbreviation
5	Alanine	A	Ala
	Arginine	R	Arg
	Asparagine	N	Asn
10	Aspartic acid	D	Asp
	Cysteine	C	Cys
	Glutamine	Q	Gln
	Glutamic acid	E	Glu
	Glycine	G	Gly
15	Histidine	H	His
	Isoleucine	I	Ile
	Leucine	L	Leu
	Lysine	K	Lys
	Methionine	M	Met
20	Phenylalanine	F	Phe
	Proline	P	Pro
	Serine	S	Ser
	Threonine	T	Thr
	Tryptophan	W	Trp
25	Tyrosine	Y	Tyr
	Valine	V	Val

The abbreviations used for the D-enantiomers of the genetically encoded amino acids are lower-case equivalents of the one-letter symbols. For example, "R" designates L-arginine and "r" designates D-arginine. When a polypeptide sequence is represented as a series of three-letter or one-letter amino acid abbreviations, it will be understood that the left-hand direction is the amino terminal direction and the right-hand direction is the carboxy terminal direction, in accordance with standard usage and convention.

35

5.2 Surface imprints

In one aspect, the invention provides surface imprint compositions comprising a matrix material having a cavity of a template molecule imprinted thereon. The cavities are oriented and localized at or near the surface of the matrix material. The
5 cavities have topographies that correspond to the topography of the template molecule. The template molecule is designed or selected to generate cavities that correspond in topography to a target molecule. The surface imprint can be used to specifically capture target molecules which bind the cavities. A target molecule “binds” a cavity if it becomes entrapped or immobilized within the cavity in a specific manner such that it is specifically
10 captured from a composition comprising it. Examples of target molecules, template molecules, and matrix materials are described in detail below.

In a surface imprint of the present invention, a substantial fraction and/or number of the imprint cavities are localized at or near the surface of the matrix material. By a “substantial fraction” is meant that substantially more cavities are localized at or near the
15 surface of the matrix material than are located at internal regions of the matrix material. By “substantial number” is meant that substantially more cavities are localized at or near the surface of the matrix material than are located at or near the surface of imprints created by conventional means. Expressed as a fraction of the total number of cavities of the imprint, the number of cavities localized at or near the surface of the imprint can be about 20%,
20 about 25%, about 33%, about 50%, about 60%, about 70%, about 80%, about 90%, about 95%, about 99%, or about 99.9%. A surface imprint can even have substantially all, or even more, of its cavities localized at or near its surface, or even all of its cavities localized at its surface.

Surface imprints of the invention also have a substantially greater density of
25 imprint cavities localized at or near their surfaces than conventional imprints. The methods of the present invention improve upon conventional techniques to such a degree that a far greater number of imprint cavities that are localized at the surface of the imprints and that are accessible to solvents and to target molecules. The density of the surface cavities of surface imprints can be from 10% to 100% greater than the density of cavities located at the
30 surface of conventional imprints. Compared to conventional imprints, the density of cavities located at the surface of the surface imprints of the invention can also be from 20% to 200% greater, from 30% to 300% greater, from 40% to 400% greater, more than 100% greater, more than 200% greater, more than 300% greater, or even more than 400% greater.

The surface imprint compositions of the invention also tend to have a
35 substantially greater number or fraction of their imprint cavities oriented with respect to the

surface of the matrix material than conventional imprints. Two imprint cavities of the same or similar template molecules are "oriented" if they have a similar or identical spatial relationship to the surface of the matrix material. For example, two imprint cavities of peptides, even peptides of different primary structures, are oriented if the portions of the cavities that correspond to the amino termini of the peptides are, for instance, closer to the surface of the matrix material than the portions that correspond to the carboxy termini, or vice versa. Two imprint cavities of single-stranded polynucleotides are oriented if the portions of the cavities that correspond to the 5' ends of the polynucleotides are, for instance, closer to the surface of matrix material than the portions that correspond to the 3' ends, or vice versa. Two imprint cavities of amphipathic molecules are oriented if the portions of the cavities that correspond, for instance, to the hydrophilic portion of the molecules are closer to the surface of the matrix material than the portions that correspond to their hydrophobic portions, or vice versa. One of skill in the art will recognize that any two imprint cavities of similar template molecules can be oriented within a matrix material. Expressed as a fraction of the total number of imprint cavities, the number of oriented cavities can be about 20%, about 25%, about 33%, about 50%, about 60%, about 70%, about 80%, about 90%, about 95%, about 99%, or about 99.9%. A surface imprint can even have substantially all, or even more, of its imprinted cavities oriented with respect to the surface of the matrix material.

Surface imprints of the present invention are superior to conventional molecular imprints because the cavities of surface imprints are homogeneously distributed and/or oriented at the surface of the imprint. As illustrated in FIG. 2, conventional imprint 10 has cavities 12', 14' and 16' distributed throughout matrix material 42'. Some of the cavities such as 12' might be localized at the surface of matrix material 42', but the majority of cavities such as 14' are not surface-accessible. Some cavities such as 16' may even contain internally trapped template molecules such as 16. In contrast, surface imprint 18 has cavities 20', 22' and 24' oriented and localized at or near the surface of the matrix material. Cavities 20', 22' and 24' contain no trapped template molecules are accessible and oriented at the surface of the imprint.

30

5.3 Methods of making imprints

The present invention also encompasses methods of making the surface imprint compositions. Virtually any method that is capable of generating molecular imprints that have a substantial fraction or number of their imprint cavities oriented and/or localized at or near the surface of the matrix material can be used to make the surface

35

imprint compositions of the invention. Two exemplary methods are described in detail below. Specific methods are provided in the Examples. It will be recognized by those of skill in the art that many available methods may be readily adapted according to the principles taught herein to make surface imprint compositions. In one exemplary method
5 described below, a two phase system with conjugate molecules partitioned at its interface is used to generate surface imprints. In another exemplary method described below, a surface imprint is formed with an immobilized template molecule.

5.3.1 A two-phase method of preparing surface imprints

10 One embodiment of forming a surface imprint composition uses an amphipathic conjugate molecule in a two-phase system. The conjugate molecule partitions to the interface of the two-phase system, and a solid or semi-solid matrix is formed in one of the two phases. The resulting matrix comprises a surface imprint of the portion of conjugate molecule at the surface of the matrix defined by the interface.

15 A general two-phase method for preparing a surface imprint of the present invention is illustrated in FIG. 3. Referring to FIG. 3A, to prepare a surface imprint that is useful for capturing target molecule 32, conjugate molecule 38 is first prepared and used to form the imprint. Conjugate molecule 38 comprises a target molecule moiety 34 and a tail moiety 36. The target molecule moiety 34 and tail moiety 36 are linked together, optionally
20 by way of a linker 35. As illustrated in FIG. 3A, template moiety 34 may be the target molecule to be captured (32). Alternatively, as illustrated in FIG. 3C, template moiety 34 may correspond to a portion (31) of a larger target molecule 33. Template moieties that correspond to portions of larger target molecules, as well as methods describing how they are designed and obtained, are described in more detail, infra.

25 Regardless of the identity or source of template moiety 34, tail moiety 36 has a hydrophobicity that complements, or is the opposite of, the hydrophobicity of template moiety 34. For example, if template moiety 34 is hydrophobic, then tail moiety 36 is hydrophilic. If template moiety 34 is hydrophilic, then tail moiety 36 is hydrophobic. As a consequence, when dissolved in a two-phase solvent system in which one phase is
30 hydrophobic and the other hydrophilic, such as an oil-and-water system, conjugate molecule 38 partitions at the interface of the two solvents. The degree of hydrophobicity or hydrophilicity of tail moiety 36 will depend on a variety of factors, including among others, the choice of solvents and the degree of hydrophobicity or hydrophilicity of template moiety 34. Methods for determining the hydrophobicities or hydrophilicities of template
35 moiety 34 and tail moiety 36 are described in more detail, infra. Tail moieties 36, and

optional linker moieties **35** (discussed below) that yield conjugates **38** capable of partitioning at the interface of the two-phase system for particular solvents and template moieties is within the capabilities of those of skill in the art.

5 Template moiety **34** and tail molecule moiety **36** are linked to one another, optionally, by way of linker **35**. Specific linkers, tail moieties and template moieties are discussed in more detail, *infra*.

 The choice of solvents used to create the two-phase system is not critical. Virtually any solvents that are immiscible with one another, that are compatible with the conjugate molecule, and that permit the conjugate molecule to partition at the interface, preferably with the template moiety residing in one phase and the tail moiety in the other, 10 can be used.

 Non-limiting examples of suitable hydrophilic (polar) solvents include water (optionally including buffering agents, salts, etc.), lower alkyl alcohols (e.g., methanol, ethanol, propanol, isopropanol, etc.), acetonitrile, dimethylsulfoxide, etc., as well as 15 mixtures of any of these solvents.

 Non-limiting examples of suitable hydrophobic (non-polar solvents) include acetone, ether, benzene, hydrocarbons such as hexane, heptane, etc., methylene chloride, carbon tetrachloride, chloroform, petroleum ether, mineral oil, phenol, etc., as well as combinations of any of the above.

20 The solvents may be used in a variety of different combinations to create two-phase systems. The actual choice of solvents will depend upon, among other things, the properties of the conjugate molecule. Suitable solvent systems will be apparent to those of skill in the art. Preferably, the solvents selected are non-toxic and non-teratogenic. A preferred two-phase system for most applications comprises water (or aqueous buffer) and 25 mineral oil.

 To prepare the surface imprint, as illustrated in FIG. 3B, conjugate molecule **38** is dispersed within composition **44**. Composition **44** comprises matrix material **42** and the two solvents: one hydrophobic (non-polar) and one hydrophilic (polar). As discussed above, the two solvents are immiscible such that they form a two-phase system, illustrated 30 as first phase **46** and second phase **48**. Preferably, template moiety **34** is soluble in one of the solutions or phases (illustrated as first phase **46**) and tail moiety **36** is soluble in the other solution or phase (illustrated as second phase **48**). Matrix material **42** is also soluble in one of the two solutions or phases, typically the same solution or phase in which the template moiety **36** is soluble.

35

Matrix material **42** is then induced to undergo a change of physical state, to form semisolid or solid matrix **42'**. Since it is disposed throughout only one of the two phases — the phase comprising template moiety **34** — as the matrix material hardens it entraps template moiety **34**. Since the conjugate molecule **38** is localized/partitioned at the interface of the two-phase system, and the template moiety **34** is oriented in the first phase **36**, removing template moiety **34** from the “hardened” matrix material **42'** yields imprint cavities **34'** that are oriented and localized at or near the surface of hardened matrix material **42'**.

During the preparation process, composition **44** may be unagitated, thereby forming a continuous sheet of hardened matrix material **42'** defining surface imprint cavities **34'**. Alternatively, the composition may be agitated, such as by sonication or other means known to those of skill in the art. During agitation or sonication, small droplets of one phase in the other or an emulsion is obtained. Agitation or sonication thus yields an increased surface area of matrix material **42'** and a greater number of surface imprint cavities **34'** per volume of matrix material **42'**. Suitable agitation and/or sonication conditions will be apparent to one of skill in the art. For instance, sonication of an aqueous acrylamide/mineral oil mixture at 60 W for 4 min to 10 min yields a surface imprint composition having a high density of surface imprint cavities.

Matrix material **42** is a compound or mixture of compounds that is capable of undergoing a change of physical state from a fluid state to a solid or semisolid state. In the fluid state, the molecules of matrix material **42** move easily among themselves, and the material retains little or no definite form. A matrix material in the fluid state can be mixed with other compounds, including template molecules. Matrix material **42** may comprise virtually any compound or mixture of compounds that is compatible with template molecule **34** and conjugate molecule **38** and that is capable of undergoing a change of physical state to form a solid or semisolid such that the changed form is capable of retaining shaped cavities. The physical state change can be induced by virtually any means, including thermal, chemical and/or electromagnetic processes. Examples of suitable matrix materials are discussed below.

During the embedding process, matrix material **42** changes physical state, or hardens, from a fluid state to a solid or a semisolid state (“hardened”) **42'** in the presence of template moiety **34**. Solid or semisolid matrix **42'** is sufficiently shape-retaining to retain imprint cavities that complement the shape of template moiety **34**. Removal of template moiety **34** from complex **46** yields surface imprint composition **48** (illustrated disposed

35

within container 49). In surface imprint composition 48, solid or semisolid matrix 42' defines cavities 34' that complement the topography of template moiety 34.

Although not illustrated, composition 44 can include a plurality of different conjugate molecules, each like conjugate molecule 38. Each conjugate molecule can

5 comprise a template moiety that corresponds to a different molecule, or a portion thereof, yielding a variation of matrix 42' that can capture a plurality of different molecules.

Alternatively, each conjugate molecule can comprise a template molecule that corresponds to a different portion of the same molecule, yielding a variation of matrix 42' that can bind or capture the molecule at a plurality of positions.

10 In one two-phase embodiment, matrix material 42 is a compound or mixture of compounds that undergoes a chemical or light induced liquid-to-solid state change, such as one or more polymerizable compounds. Examples of suitable polymerizable compounds include, but are not limited to, styrene, methyl methacrylate, 2-hydroxyethyl methacrylate, 2-hydroxyethyl acrylate, methyl acrylate, acrylamide, vinyl ether, vinyl acetate,

15 divinylbenzene, ethylene glycol dimethacrylate, ethylene glycol diacrylate, pentaerythritol dimethacrylate, pentaerythritol diacrylate, N,N'-methylenebisacrylamide, N,N'-ethylenebisacrylamide, N,N'-(1,2-dihydroxyethylene)bis-acrylamide and trimethylolpropane trimethacrylate, vinyl cyclodextrin, and polymerizable cyclodextrin. Further examples of polymerizable compounds that are useful for the preparation of surface

20 imprints can be found in U.S. Patent No. 5,858,296, which is hereby incorporated by reference in its entirety. Methods for inducing polymerization of these compounds are well-known. A preferred polymerizable compound is acrylamide.

The use of such polymerizable compounds is illustrated in FIG. 3C, where the matrix material 42 is referred to in this paragraph as polymerizable compound 42.

25 Referring to FIG. 3C, conjugate molecule 38 and a polymerizable compound 42 are mixed in a solvent that is suitable for polymerization of polymerizable compound 42. If necessary, an initiator for the polymerization of the polymerizable compound is included. Optionally, the conjugate molecule 38 can be covalently bound to the polymerizable compound 42, or the two can be allowed to form non-covalent complexes. Polymerization can be started by

30 adding an appropriate catalyst such as ultraviolet radiation. After polymerization is complete, the conjugate molecule 38 is removed by diffusion, incubation in a chaotropic reagent such as urea or guanidine, or by other techniques known to those of skill in the art.

Cross-linking reagents can be optionally used with a polymerizable compound 42 to confer rigidity to the resultant surface imprint. The present invention

35 contemplates any ratio of polymerizable compound to cross-linking reagent that yields a

surface imprint of sufficient integrity to form a cavity whose shape corresponds to the shape of the template molecule. Cross-linking reagents are known to those of skill in the art. Examples of such cross-linking reagents can be found in U.S. Patent No. 5,858,296. Preferred surface imprints are prepared with acrylamide and the cross-linking reagent
5 ethylene glycol dimethacrylate (EGDMA).

In another embodiment, matrix material **42** is a sol-gel material. Referring to FIG. 3B, to make an imprint composition using such a sol-gel material, conjugate molecule **38** and sol-gel material **42** are mixed under conditions in which sol-gel material **42** is in a fluid or semi-fluid state. Sol-gel material **42** is allowed or induced to form a solid or a
10 semisolid state, and the conjugate molecule **38** is removed to form hardened matrix material **42'**. In the two-phase embodiment illustrated in FIG. 3C, conjugate molecule **38** and sol-gel material **42** are mixed in a solvent that is suitable for the hardening of sol-gel material **42**. Optionally, the conjugate molecule **38** can be covalently bound to the sol-gel material **42**, or the two can be allowed to form non-covalent complexes. Sol-gel material **42** is allowed or
15 induced to form a solid or a semisolid state **42'**, and conjugate molecule **38** is removed to form imprint composition **48**. Specific conditions including solvent, temperature, catalyst, and monomer, can be selected to tailor properties of hardened matrix material **42'** or imprint composition **48** such as porosity, pore size, density, surface area and surface hydrophobicity. Sol-gel materials and detailed methods of making imprints comprising
20 those materials can be found, for instance, in Dickey, 1949, *supra*; Dickey, 1955, *J. Phys. Chem.* 59: 695; Brinker *et al.*, 1982, *J. Non-Crystal. Solids* 48:47; Glad *et al.*, 1985, *J. Chromatography* 347: 11; Wulff *et al.*, 1986, *J. Am. Chem. Soc.* 108: 1089; Pinel *et al.*, 1997, *Adv. Mater.* 9: 582-5; U.S. Patent No. 6,057,377 and Katz & Davis, 2000, *Nature* 403:286-289, the disclosures of which are hereby incorporated by reference in their entirety.
25 Preferred sol-gel materials include those that are formed from tetraethoxysilane or tetramethyloxysilane.

In general, matrix material **42** and conjugate molecule **38** can be contacted under any conditions which permit matrix material **42** to change its physical state to a solid or semisolid matrix **42'**. For instance, matrix material **42** and conjugate molecule **38** can be
30 contacted under native conditions or under denaturing conditions. "Native conditions" and "denaturing conditions" can be defined with respect to the template moiety or with respect to the target molecule according to principles known to those of skill in the art. Preferably, the conditions under which matrix material **42** embeds template moiety **34** are similar or identical to the conditions under which molecule **32** or **33** will be captured.

35

The concentration of matrix material 42, conjugate molecule 38, and an optional cross-linking reagent can be determined according to principles known to those of skill in the art of molecular imprinting. In particular, the number of cavities 34' in matrix 42' can be adjusted by varying the concentration of conjugate molecule 38. The
5 concentration of conjugate molecule 38 can vary widely without deleteriously affecting the methods or resultant surface imprint compositions, typically from as low as 0.01 mM and as high as 1 M.

Once the matrix material 42' is in a solid or semi-solid state, second phase 48 is removed from matrix material 42'. Conjugate molecule 38 is removed by diffusion or by
10 other techniques known to those of skill in the art. If conjugate molecule 38 comprises a cleavable linker 35, then cleavable linker 35 can be cleaved to remove tail moiety 36. Template moiety 34 can then be removed via diffusion or other techniques as previously described. Methods for removing conjugate 38 via washing are described in the Examples.

The surface imprints can take on a variety of forms. Usually, the surface
15 imprint will initially take on the same form as the container used to create hardened matrix 42'. However, any shape that might be useful for capturing molecules is possible. For example, the imprint compositions may be in the form of individual beads, disks, ellipses, or other regular or irregular shapes (collectively referred to as "beads"), or in the form of sheets. Beads can be formed by grinding imprint composition 48 or by suspension and
20 dispersion techniques, as are well-known in the art. Methods of making imprinted beads are discussed in Damen et al., 1980, J. Am. Chem. Soc. 102:3265-3267; Braun et al., 1984, Chemiker-Zeitung 108:255-257; and Bystrom et al., 1993, J. Am. Chem. Soc. 115:2081-2083. Imprinted beads may also be prepared by imprinting in the pore network of preformed beaded silica as discussed in Wulff et al., 1985, Reactive Polymers 3:261-2757.
25 Dispersion techniques are discussed in Selligren et al., 1994, 673:133-141. The formation of beaded surface imprints by suspension polymerization is described in U.S. Patent No. 5,821,311.

5.3.2 Methods utilizing immobilized template molecules

30 In another exemplary embodiment, a surface imprint can be prepared by imprinting an immobilized template molecule or an immobilized conjugate molecule. A template molecule or conjugate molecule is first immobilized on a solid support by any technique known to those of skill in the art such as those described below. The linking group can optionally be cleavable by any means including chemicals, enzymes, or
35

electromagnetic radiation as discussed below. The solid support can be glass, acrylic, plastic, a film, or any other substrate known to those of skill in the art.

The imprint compositions of the invention can be prepared according to any of the known techniques for making molecular imprints with one modification. Instead of
5 creating an imprint with a free template molecule, the imprint compositions of the invention are created with an immobilized template molecule or conjugate molecule. Non-limiting examples of suitable techniques that can be used in conjunction with the invention are described, *e.g.*, in U.S. Patent No. 5,858,296; U.S. Patent No. 5,786,428; U.S. Patent No. 5,587,273; U.S. Patent No. 5,821,311; U.S. Patent No. 5,814,223; and U.S. Patent No.
10 5,757,717; U.S. Patent No. 5,994,110; U.S. Patent No. 5,959,050; U.S. Patent No. 5,916,445; U.S. Patent No. 5,872,198; U.S. Patent No. 5,814,223; U.S. Patent No. 5,728,296; U.S. Patent No. 5,630,978; and U.S. Patent No. 5,310,648, the disclosures of which are incorporated herein by reference.

A general method for preparing an imprint composition of the present
15 invention with an immobilized template molecule is illustrated in FIG. 3B. Referring to FIG. 3B, an immobilized template molecule **50** is contacted with a matrix material **42** under conditions in which template molecule **50** becomes entrapped or embedded within matrix material **42**, yielding a complex.

In this embodiment, matrix material **42** may be as described above.
20 Additionally, matrix material **42** may be a solid or semisolid compound that liquifies upon application of heat and resolidifies when the heat is removed. Referring to FIG. 3B where matrix material **42** is referred to as "heat-sensitive compound", to make an imprint composition according to the invention using such a heat sensitive compound, conjugate molecule **38** and heat sensitive compound **42** are mixed under conditions in which heat
25 sensitive compound **42** liquifies. The heat source is then removed and, as the liquid cools it solidifies to form complex **46**. Removal of conjugate molecules **38** *via*, for example, diffusion, yields imprint composition **48**. Of course, in order to maintain the integrity of cavities **34'**, imprint composition **48** should be kept at temperatures below the liquification temperature of heat sensitive compound **42** during storage and subsequent manipulations.

30 Many heat-sensitive compounds that can be used to make imprint compositions according to the invention are known in the art and include, by way of example and not limitation, hydrogels such as agarose, gelatins, moldable plastics, etc. Examples of other suitable hydrogels are described in U.S. Patent No. 6,018,033; U.S. Patent No. 5,277,915, U.S. Patent No. 4,024,073, and U.S. Patent No. 4,452,892, the
35 disclosures of which are incorporated herein by reference. Preferably, the temperature at

which the matrix material **42** liquifies will be in a range that does not destroy or otherwise substantially degrade the conjugate molecule **38**.

During the embedding process, matrix material **42** changes physical state from a fluid state to a solid or a semisolid state **42'** in the presence of template molecule **50**.
5 In the solid or semisolid state, matrix **42'** is sufficiently shape-retaining to retain cavities that complement the shape of template molecule **50**. Removal of the substrate and template molecule **50** yields surface imprint composition **42'** defining imprint cavity **50'**. Template molecule **50** can be removed by diffusion or by other techniques known to those of skill in the art. If template molecule **50** is immobilized by a cleavable group, template molecule **50**
10 can preferably be cleaved to facilitate removal of the substrate and template molecule **50** from surface imprint composition **42'**.

As illustrated in FIG. 3B, a surface imprint can also be prepared by imprinting an array of template molecules. The same techniques described above are applied to an array of template molecules, such as **50** and **51**, that are immobilized on a
15 substrate. The immobilized array of template molecules is contacted with matrix material **42** under conditions in which the array of template molecules becomes entrapped within matrix material **42**. Matrix material **42** changes physical state to a solid or semisolid matrix material **42'**. The array of template molecules is then removed yielding an array of surface imprints defining imprint cavities **50'** and **51'**. The methods of the present embodiment can
20 be applied to any immobilized array of template molecules.

Methods for making myriad different types of immobilized template molecules are well-known. For example, methods for synthesizing peptide template molecules immobilized on synthesis substrates are described in Merrifield, 1997, *Meth. Enzymol.* 289:3-13; methods for synthesizing oligonucleotide template molecules
25 immobilized on synthesis substrates are described in Southern et al., 1994, *Nuc. Acids Res.* 22:1368-1373. A plethora of reactions available for synthesizing a wide variety of other types of immobilized template molecules are described in Bunin, 1998, *The Combinational Index*, Academic Press, San Diego, CA.

The template molecule can be optionally spaced away from the solid support
30 via a spacer molecule. The spacer molecule may be rigid, semi-rigid or flexible, hydrophilic or hydrophobic, long or short, etc. A plethora of spacers suitable for spacing molecules from solid supports are known in the art. Any of these spacers can be used to space the template molecule from the solid support. The actual choice of spacer molecule will depend upon, among other things, the nature of the template molecule, the length vs.
35 rigidity of the spacer, etc., and will be apparent to those of skill in the art. The spacer may

be selectively cleavable to aid removal of the solid support without tearing the resulting imprint composition, as will be further illustrated below.

A surface imprint composition of the present invention may also be prepared by imprinting an immobilized array of template molecules. Such arrays of immobilized
5 template molecules can be prepared according to well-known techniques. For example, an immobilized template molecule or an immobilized array of template molecules can be prepared by spotting template molecules onto a substrate under conditions in which the template molecule is covalently or non-covalently attached to the substrate using any of the spotting devices described in U.S. Patent No. 5,601,980, U.S. Patent No. 6,001,309, U.S.
10 Patent No. 5,785,926, and U.S. Patent No. 4,877,745. Any of these devices, or other devices useful for dispensing small aliquots of liquids into substrates, can be adapted for use to create the desired array of template molecules.

Alternatively, the array of template molecules may be prepared by synthesizing in situ each template molecule at its desired address or location within the
15 array. Several in situ synthesis methods useful for making arrays of template molecules have been described in the art. For instance, an array of peptides immobilized on a substrate can be prepared according to, for example, U.S. Patent No. 5,958,703; U.S. Patent No. 5,919,523; U.S. Patent No. 5,847,105; or U.S. Patent No. 5,744,305. An array of oligonucleotides immobilized on a substrate can be prepared according to, for example,
20 U.S. Patent No. 5,919,523; U.S. Patent No. 5,843,655, U.S. Patent No. 5,143,854; U.S. Patent No. 5,847,105; U.S. Patent No. 5,837,832; U.S. Patent No. 5,770,722; PCT application No. WO 92/10092; or PCT application No. WO 90/15070.

A significant advantage of preparing the arrays of the invention from template arrays is the dimensions that can be achieved. Template arrays prepared by
25 spotting or in situ synthesis methods can readily be prepared that have synthesis spots of features on the order of 10-100 μm , permitting the synthesis of tens of thousands, or even millions, of different template molecules in a substrate area measuring about 1 cm on each edge (see, e.g., Fodor et. al., 1991, supra). Imprint arrays created with such template arrays will have similar dimension and complexities. Thus, imprint arrays capable of capturing
30 tens of thousands, hundreds of thousands or even millions of unique macromolecules that measure only 1 cm per array axis can be readily prepared. The ability to create such miniature array imprints makes it possible, for the first time, to analyze the plethora of macromolecules present in complex samples such as cells. Due to their miniature dimensions, very little sample is required for analysis. Moreover, since template arrays at
35 different types of template molecules can be prepared (e.g., an array comprising both

peptide and oligonucleotide template molecules), different types of macromolecules can be captured and analyzed simultaneously.

In instances where the array of molecular imprints is prepared with an array of immobilized template molecules, the template molecules can be optionally spaced away
5 from the solid support or substrate via a selectively cleavable spacer. The array of molecular imprints can then be prepared by forming imprints, according to one of the methods described above, in the presence of the array of template molecules immobilized on a support. The template molecules can then be cleaved from the support prior to
10 removing the support from the newly formed molecular imprints. Cleavable spacers can be cleaved with chemicals, enzymes, or electromagnetic radiation. If the linkage can be cleaved with electromagnetic radiation and the transition of matrix material **42** can also be induced by electromagnetic radiation, the wavelength of the radiation that cleaves the spacer should be compatible with the wavelength of the radiation that induces the transition of the matrix material. Cleaving a labile spacer allows the template molecules to be removed from
15 the molecular imprints, according to one of the methods described above, with minimal disruption of the integrity of the molecular imprints. The remaining portions of the template molecules can be removed by diffusion or by incubation in a chaotropic reagent such as urea or guanidine or by other techniques known to those of skill in the art for disrupting molecular complexes. Cleavable spacers suitable for attaching template
20 molecules are known to those of skill in the art. Appropriate examples are described, for instance, in U.S. Patent No. 5,766,556; U.S. Patent No. 5,095,084; U.S. Patent No. 6,013,440; U.S. Patent No. 5,962,337; and U.S. Patent No. 5,958,703.

5.4 Targets

25 The surface imprints of the present invention can be used to detect, capture, isolate, analyze and/or quantify any target molecule. Target molecules specifically include any species that has a three-dimensional topography that is capable, at least in part, of binding cavities in a matrix material that correspond at least a portion of the three-dimensional topography of the target. Typical examples include, by way of example and
30 not limitation, organic molecules, small molecules, therapeutic molecules, polymers, macromolecules and biological macromolecules. However, targets are not limited to molecular substances, as the surface imprints of the present invention can be used to capture substances as large as viruses and bacteria or even larger objects.

In several important embodiments, target molecules are macromolecules.
35 Macromolecules that can be captured, isolated, detected, analyzed and/or quantified using

the imprint compositions of the invention include any type of macromolecule from which a template molecule can be designed and constructed according to the principles taught herein. Virtually any type of macromolecule can be captured, isolated, detected, analyzed and/or quantified using the methods and compositions of the invention. Non-limiting
5 examples include biological polymers such as polypeptides, polynucleotides and polysaccharides, non-biological polymers such as polyesters, polyethers, polyurethanes, block co-polymers, and other polymers known to those of skill in the art. Non-limiting examples also include biological and non-biological non-polymeric compounds such as antibiotics, steroids, natural products, dyes, etc. Thus, non-limiting examples of the myriad
10 types of macromolecular that may be captured, isolated, detected, analyzed and/or quantified using the methods and compositions of the invention include cytokines, hormones, growth factors, enzymes, cofactors, ligands, receptors, antibodies, carbohydrates, steroids, therapeutics, antibiotics, and even larger structures such as viruses or cells, and other macromolecular targets that will be apparent to those of skill in the art.

15

5.5 Template molecules

As discussed above, the imprint compositions of the invention are prepared from a template molecule. The template molecule can be the target molecule to be captured, it can correspond to the entire structure of the target molecule, or the template
20 molecule can correspond to a portion of the target molecule. A template molecule “corresponds” to the entire structure of the target molecule if it possesses the structural features of the target molecule as described below.

The template molecule can possess structural features of a molecule by way of structural identity with the molecule or portion. Alternatively, the template molecule can
25 possess structural features of the molecule or portion by mimicking those structural features of the molecule. The only requirement of the template molecule is that it comprises a three-dimensional structure that is similar enough to the structure of the molecule or portion so that the molecule or portion specifically fits within a cavity formed by the template molecule.

30 A template molecule can correspond to a target molecule without being identical to the target molecule. Those of skill in the art will recognize that a template molecule need not have exact structural identity with the target molecule in order to “correspond” to it. Often, a template molecule may incorporate topographic substitutions. A substitution is “topographic” if the topography of the template molecule creates a cavity
35 that binds the corresponding target molecule. Preferably, a template with a topographic

substitution creates an imprint that specifically binds the corresponding target molecule. Template molecules comprising topographic substitutions, and that therefore do not correspond identically to the target molecule, are said to correspond substantially to the target molecule. Thus, unless specifically indicated otherwise, as used herein, the
5 expression “corresponds to” is intended to encompass those situations where a template molecule corresponds identically or substantially to a molecule of interest. The correspondence between the topography of the template molecule and the topography of the target molecule should be close enough so that the target molecule fits specifically within an imprint or a cavity formed by the template molecule (see, *e.g.*, FIG. 1).

10 The closeness of the correspondence between the template molecule and the molecule of interest will depend upon the desired degree of specificity between the imprint and the target molecule. Template molecules that correspond identically to the entire target molecule are expected to exhibit the highest degree of specificity for the molecule. Thus, the closeness of correspondence will depend upon the complexity of the separation, and will
15 be apparent to those of skill in the art.

Template molecules that correspond to an entire molecule or to a portion of a molecule can be prepared according to known principles. In many instances the template molecule is simply the same molecule as the target molecule. In other instances the template molecule can be a derivative of the target molecule. For instance, the target
20 molecule can be modified so that it can be linked to a tail molecule as described below. Alternatively, the template molecule can mimic the topography of the target molecule.

Those of skill in the art will also recognize that in many instances compounds that mimic the structures of other compounds are known. For example, peptidomimetic compounds mimic the structures of peptides. The template molecule may
25 comprise, in whole, or in part, such mimetic structures. Mimetic compounds that can be used to create template molecules, as well as their use to create template molecules, will be apparent to those of skill in the art. All that is required is that the three dimensional surface of the mimetic template compound have a three dimensional surface with sufficient correspondence to the surface of the mimicked molecule to create a cavity that specifically
30 fits the molecule.

If the target molecule is a macromolecule, a preferred template molecule corresponds to a portion of the macromolecule of interest. A template molecule “corresponds” to a portion of the macromolecule if it possesses the structural features of that portion of the macromolecule and substantially no other structural features of the
35 macromolecule outside that portion. The template molecule can possess structural features

of the macromolecule by way of structural identity with the portion of the macromolecule. Alternatively, the template molecule can possess structural features of the portion of the macromolecule by approximating or mimicking the structure of at least one structural moiety of the portion of the macromolecule. A detailed description of template molecules
5 that correspond to portions of macromolecules are described in detail in copending application Serial No. 09/507,300, supra.

5.6 Template molecules for preparing imprints useful for capturing novel macromolecules

10 Template molecules that comprise the structure of a known molecule or that correspond to a portion of a known molecule are most useful for capturing known molecules. However, in another important embodiment, the present invention is also useful for capturing, isolating, detecting, analyzing, quantifying and/or identifying novel
15 molecules. In this embodiment, the template molecule useful for preparing imprints which can capture novel molecules, even those for which no structural information is known.

In this embodiment, the template molecule can be any molecule that might be useful for capturing a novel molecule. For instance, the template molecule can be a small molecule that is useful for preparing surface imprints that can be used to capture novel molecules of similar structure. The template molecule can be selected from a
20 combinatorial library, or any other library of molecules known to those of skill in the art. Any template molecule that can be linked to tail molecule to form a conjugate molecule, as described below, is useful for preparing surface imprints of the present invention.

In particular, template molecules of this embodiment are useful for preparing imprints that can capture a novel macromolecule. A novel macromolecule is a
25 macromolecule for which limited or no structural or functional information is available. If any structural information is available, a molecular imprint can be prepared using a template molecule that corresponds to the portion of the available structural information as described above. The template molecule can also correspond to all of the available structural information. When no structural information is known about a macromolecule, but it is
30 known to be functionally related to a known macromolecule, the template molecule can correspond to a portion of a macromolecule having similar function, the template molecule can correspond to a portion of a macromolecule with similar function, or the template molecule can correspond to a consensus sequence of a family of macromolecules with similar function. In addition, for any novel macromolecule, even one for which no
35 structural or functional information is available, a molecular imprint of a template molecule

with a random structure might be able to capture the novel macromolecule. For example, an as yet unidentified macromolecule can be captured, isolated, detected, analyzed and identified from a complex sample with such a molecular imprint. Template molecules appropriate for creating surface imprints that can capture novel macromolecules are
5 described in detail in copending Application Serial No. 09/507,300, supra.

5.7 Conjugate molecules

The conjugate molecule comprises a tail moiety and a template moiety. The conjugate molecule partitions to an interface of a multiple-phase system because of its
10 amphipathic character. Template moieties constitute template molecules, which are described in detail above, that are to be imprinted.

Since the structure of the template moiety is determined by the structure of the target molecule, the amphipathic character of the conjugate molecule is established by careful selection of the tail moiety based on the properties of the template moiety. The tail
15 moiety should complement the hydrophobicity of the template moiety. For example, if the template moiety is hydrophobic, then the tail moiety is hydrophilic. Alternatively, if the template moiety is hydrophilic, then the tail moiety is hydrophobic. More generally, referring to FIG. 3B, in the two-phase method, the template moiety is soluble in phase 46
20 which comprises matrix material 42. The tail moiety should be chosen so that the conjugate molecule partitions to an interface of phases 46 and 48. Preferably, the tail moiety is chosen so that it is soluble in phase 48.

In a non-limiting example, template moiety 34 can be a peptide. The hydrophobicity of template moiety 34 can be determined according to techniques known to those of skill in the art such (Eisenberg, 1984, Ann. Rev. Biochem. 53:595-623; Eisenberg,
25 1984, J. Mol. Biol. 179:125-142; Eisenberg et al., 1982, Nature 299:371-374; Kyte and Doolittle, 1982, J. Mol. Biol. 157:105-32). In the instance where the template polypeptide is hydrophilic, then a hydrophobic tail moiety is chosen.

Non-limiting examples of suitable hydrophilic tail molecule moieties include molecules that bear permanent charges (*e.g.*, quaternary amines and molecules comprising
30 quaternary amines), cations derived from strong bases, anions derived from strong or organic acids (*e.g.*, $-C(O)O^-$, $-P(O)_2(O^-)$, $-P(O)(OH)(O^-)$, $-O-P(O)_2(O^-)$, $-S(O)_2O^-$, $-O-S(O)_2O^-$ and molecules comprising any of these groups or combinations thereof), polar molecules (*e.g.*, alkyl or aryl groups substituted with one or more $-OH$, $-SH$, $-NH_2$, $=O$, $-C(O)H$, $-C(O)OH$, $-C(O)O$ -alkyl and $-C(O)NH_2$ groups, polyalkylene glycols such as polyethylene
35 glycol and polypropylene glycol, saccharides, oligosaccharides, polysaccharides, organic

polymers such as polylactide and polyglycolide, organic block polymers such as PLGA, hydrophilic polypeptides such as polylysine, polynucleotides, etc.) and molecules comprising heteroatoms (e.g., furan, imidazole, isothiazole, isoxazole, pyrazine, etc.). The necessary degree of hydrophilicity will depend upon a variety of factors, including, among
5 others, the solvents used to create the two-phase system and the hydrophobicity of the template molecule moiety, and will be apparent to those of skill in the art.

Non-limiting examples of suitable hydrophobic tail molecule moieties include straight-chain, branched, cyclic and polycyclic hydrocarbons, cyclic and polycyclic aryls, fatty acids such as palmitic acid, lipids, phospholipids, steroids, cholesterol and
10 derivatives thereof, hydrophobic polypeptides, etc. The necessary degree of hydrophobicity will depend upon a variety of factors, including, among others, the solvents used to create the two-phase system and the hydrophilicity of the template molecule moiety, and will be apparent to those of skill in the art.

The template moiety is covalently linked to the tail moiety by any method
15 known to those of skill in the art either directly or by way of an optional linker. The actual linkage will depend upon the identities of the template moiety and the tail moiety and will be apparent to those of skill in the art. For example, a hydrophilic peptide template moiety and a hydrophobic peptide tail moiety can be linked at their respective N- and C- termini to form an amide linkage. Alternatively, the template moiety and the tail moiety can be linked
20 by a linker 35. Linker 35 can be any molecule used by those of skill in the art to link two other molecules. Any of the spacers previously described in connection with immobilized template molecules, supra, can constitute linker 35. Other suitable linkers 35 will be apparent to those of skill in the art. For example, bifunctional reagents are known to those of skill in the art and are commercially available. The linker molecule can form a covalent
25 linkage between the template moiety and the tail moiety, or the linkage can be non-covalent.

The linkage between the template moiety and the tail moiety can be optionally cleavable. Cleavable linkages are known to those of skill in the art and include linkages that can be cleaved with chemicals, enzymes, or electromagnetic radiation. If the linkage can be cleaved with electromagnetic radiation and the transition of matrix material
30 42 can also be induced by electromagnetic radiation, the wavelength of the radiation that cleaves the linkage should be compatible with the wavelength of the radiation that induces the transition of the matrix material.

Cleavable linkages are especially useful in preparing surface imprints of an array of conjugate molecules immobilized on a solid support. Once the solid or semisolid
35 matrix is formed, the linkage can be cleaved to facilitate removal of the solid support from

the matrix with minimal disruption of the cavities embedded in the matrix. The remaining portions of the conjugate molecules can be removed by diffusion or by incubation in a chaotropic reagent such as urea or guanidine or by other techniques known to those of skill in the art for disrupting molecular complexes.

5

5.8 Arrays of surface imprints

The present invention also provides arrays of surface imprint compositions. The arrays may be comprised of a plurality of individual imprint compositions arranged in an array or pattern or may comprise a single piece or sheet of matrix having a plurality of
10 imprint cavities imprinted thereon. In this latter embodiment, the imprint cavities are arranged in an array or pattern. The arrays may be one-dimensional, two-dimensional or three-dimensional. For instance, if the array comprises individual beads, a one-dimensional array can be prepared by introducing the beads into a capillary tube. A two-dimensional array can be prepared by distributing the beads into the wells of a microtiter plate and/or by
15 affixing the individual beads onto a substrate.

For example, referring to FIG. 4A, the array can be an ordered pattern of individual beads 60 where each bead 60 is an imprint composition of the invention. As illustrated in FIG. 4A, the individual beads 60 may be disposed within a housing 62. Housing 62 can serve the dual purpose of retaining the ordering of individual beads 60 and
20 providing a structure through which the sample may be flowed. The ends of the capillary tube may be optionally plugged with, for example, glass wool, a frit, or other porous materials to hold the beads in the tube during sample flow.

Alternatively, individual beads 60 could be distributed, either singly or in pluralities, amongst the wells of, for example, a microtiter plate, or affixed to the surface of
25 a substrate, such as a glass plate, plastic sheet or film, etc. For example, referring to FIG. 4B, individual imprints 60 (in this case illustrated as square pads) can be affixed onto glass sheet 64 in an ordered two-dimensional matrix. Methods for fixing polyacrylamide pads that can be adapted to create arrays according to the invention are described in U.S. Patent No. 5,552,270. Methods of affixing other types of matrix materials onto substrates are
30 well-known and will be apparent to those of skill in the art.

As illustrated by the above examples, a key feature of the arrays of the invention is the ability to correlate the identity of a particular imprint with its relative position within the array. Thus, in the array illustrated in FIG. 4B, the identity of a particular imprint 60 is identifiable by its xy-coordinates within the array. In the array
35 illustrated in FIG. 4A, the identity of a particular imprint 60 is identifiable by its x-

coordinate within the array. This feature is particularly useful for detecting, capturing, isolating, analyzing and/or quantifying pluralities of molecules in complex samples, as will be discussed in more detail, below.

The arrays of the invention also include matrices which have pluralities of
5 imprint cavities disposed at defined relative positions. For example, referring to FIG. 4C, a single sheet of matrix material 42' may comprise an ordered arrangement of imprint cavities 34'.

In the arrays of the invention, each array element (i.e., each set of array
10 coordinates) may be unique, i.e., each address in the array may contain an imprint of a different template molecule, or alternatively, the array may comprise redundancies. Moreover, while in many instances each array element will comprise imprint cavities of a single template molecule, one or more of the array elements may comprise imprint cavities of 2 or more different template molecules.

The number of elements comprising the array can vary over a wide range,
15 from as few as 2 to as many as 10, 10², 10³, 10⁴, 10⁵, 10⁶ or even more, and is limited only by the ability to make an array having the desired complexity, as will be described in more detail, below.

The spatially identifiable arrays of the invention provide the ability to screen
and/or analyze complex samples. For example, referring to FIG. 5, imprint array 80 is
20 constructed from template array 70. Template array 70 comprises a plurality of template molecules 71, 73, 75 and 77 which uniquely correspond to molecules 72, 74, 76 and 78, respectively. Imprint array 80 comprises matrix 42' which defines cavities 71', 73', 75' and 77' which correspond to template molecules 71, 73, 75 and 77, respectively. Because
25 template array 70 is spatially identifiable (i.e., the identities of the template molecules are known or identifiable by their coordinates or relative positions within the array), imprint array 80 is also spatially identifiable. Moreover, since the template molecules uniquely correspond to their respective molecules, imprint array 80 can be used to detect the presence of molecules 72, 74, 76 and 78 in a sample. For example, referring to FIG. 5, imprint array
30 80 is contacted with a sample comprising molecules 72, 74 and 79 under conditions in which the molecules bind their respective imprint cavities. Molecules 72 and 74 are captured at locations corresponding to cavities 71' and 73'. When the array is scanned for bound molecules, the presence of molecules at the addresses corresponding to templates 71 and 73 reveals that the sample contained molecules 72 and 74. molecules 79 is not
35 detected, as imprint array 80 does not contain an address or element capable of binding this molecule.

A spatially identifiable array of surface imprints is particularly useful when an array of surface imprints of template molecules is used to screen a complex mixture in order to isolate novel molecules. Structural information about any captured novel molecule can be deduced from the position at which it binds the array. The a portion of the captured
5 novel molecule must have a structure that corresponds to the structure of the template molecule that was used to create the imprint at that position in the array. If the captured, novel molecule is a protein and the surface imprints is an imprint of a peptide template molecule, then a portion of the amino acid sequence of the captured protein might even be identical to the amino acid sequence of the peptide template molecule.

10

5.9 Methods of capturing target molecules

Also within the scope of the present invention are methods of using surface imprints to capture target molecules. Surface imprints useful for methods of capturing target molecules can be prepared as described above. To capture a molecule, the molecule
15 or a mixture comprising the molecule is contacted with the molecular imprint under conditions in which the molecule binds the imprint.

Preferably, the conditions for contacting the target molecule with the imprint are similar to or identical to the conditions under which the imprint was formed. The choice of conditions depends on the target molecule and the template molecule. When the target
20 molecule is a protein and the template molecule corresponds to sequence of amino acids of the protein, the preferred capture conditions are often denaturing. However, when a template molecule corresponds to a large fragment of a protein, such as a pepsin fragment of an immunoglobulin, then native imprinting and capture conditions will often yield superior results. When the target molecule is a double-stranded polynucleotide, the
25 preferred capture conditions are native conditions that allow the target molecule to maintain its native structure. When the target molecule is a single-stranded polynucleotide, the capture conditions may be native or denaturing conditions. One of skill in the art will recognize whether native or denaturing conditions are appropriate. In situations where the choice of imprinting and capture conditions is not clear, the molecular imprint compositions
30 of the present invention can be prepared so efficiently and inexpensively that a series of conditions can be assayed to determine the ideal conditions.

The exact conditions to retain a native or denatured structure are well-known and will be apparent to those of skill in the art. For instance, denaturing conditions for polypeptides can include SDS, urea, guanidine, or any other protein denaturant known to
35 those of skill in the art. Denaturing conditions for polynucleotides can include high

temperature, formamide, high ionic strength, and other conditions known to those of skill in the art.

For capture, the surface imprint compositions may be disposed within a housing to create a chromatography column, or used batch-wise. The surface imprint
5 compositions can also be disposed in a capillary tube. Surface imprint compositions in a capillary tube can be used to capture the same target molecule. In addition, in an advantageous embodiment, surface imprint compositions in a capillary tube can be used to capture different target molecules. If the identity of each surface imprint composition in the capillary tube is known, the identity of a bound target molecule can then be determined by
10 the position of its binding in the capillary tube.

A plurality of target molecules can be captured simultaneously by contacting the target molecules with an array of the invention. The amount of a target molecule in a sample can be quantified by capturing the target molecule with a molecular imprint and determining the amount of the target molecule captured by the imprint. Techniques for
15 detecting a captured molecule or quantifying the amount of a captured molecule include infrared spectroscopy, UV spectroscopy, visible spectroscopy, surface acoustic wave devices, refractive index, evanescent wave sensors, bulk acoustic wave devices, capacitance measurements, radioimmunoassay measurements, radiolabeling, chemiluminescence measurements, SYPRO dyes (Steinberg *et al.*, 1996, *Anal Biochem.* 239:223-37; Molecular
20 Probes, Eugene, OR), Lamb-wave measurements, fluorescence measurements, fluorescent particles, Wilhelmy balance, chemiresistor measurements, electrochemical sensors, enzyme-linked immunosorbent assay, resistance, capacitance, acoustic wave, surface plasmon resonance, scanning tunneling microscopy, atomic force microscopy, scanning electron microscopy, rolling circle amplification, quantum dots and other techniques known to those
25 of skill in the art for detecting or quantifying molecules such as those described in U.S. Patent No. 5,306,644; U.S. Patent No. 5,313,264; U.S. Patent No. 5,955,729; and U.S. Patent No. 5,976,466.

In one representative embodiment, captured molecules can be detected or quantified by measuring the change in ultraviolet absorbance of the array of imprints before
30 and after capture. Alternatively, the change in resistance or capacitance of the array before and after capture can be used to detect captured molecules or quantify the amount of captured molecules. In another embodiment, a plurality of macromolecules can be radioactively labeled by covalent modification with a radioactive reagent or by synthesizing the macromolecules from radioactively labeled precursors. Captured molecules can then be
35

detected or quantified by counting radioactive emissions from the array by techniques well-known to those of skill in the art.

The relative amounts of a plurality of different target molecules can be quantified by capturing the plurality of target molecules and quantifying the amount of each target molecule of the plurality bound to the imprints. In a preferred embodiment, the identity of each imprint is determinable from its relative position within the array. An array of imprints wherein the identity of each imprint is determinable can be prepared from an array of template molecules wherein the identity of each template molecule is determinable from its relative position within the array. Methods of preparing such arrays of template molecules are known to those of skill in the art.

An array of surface imprints according to the present invention is useful for determining the relative amounts of target molecules from a complex biological source. This embodiment of the invention specifically encompasses the evaluation of an expression profile of a cell. In this embodiment, the complex mixture of target molecules comprises a plurality of polypeptides from a cell. An array of imprints is prepared using template molecules that correspond to portions of the polypeptides of the plurality. The plurality of polypeptides is contacted with the array of imprints. The absolute or relative amount of each polypeptide captured by the array of imprints is determined by a method of quantifying polypeptides known to those of skill in the art. For example, the cell that is the source of the plurality of polypeptides can be grown in the presence of radioactively labeled amino acids. The amount of each polypeptide bound by the array can then be determined by scintillation counting or by photographic exposure and densitometry. Alternatively, if antibodies are available for the polypeptides of the plurality, the amount of the polypeptides bound by the array of imprints can be determined by ELISA methods or other methods known to those of skill in the art. If each imprint of the array is on a discrete matrix, then the amount of each bound polypeptide can be determined directly by a protein assay known to those of skill in the art such as the assay described in Lowry *et al.*, 1951, *J. Biol. Chem.* 193: 265-220, or the assay described in Bradford, 1976 *Anal. Biochem.* 72: 248-254. The expression profile of the polypeptides of the plurality can be derived from the relative amounts of each polypeptide of the plurality that is bound by the array of imprints.

A captured target molecule can be analyzed by any of the techniques discussed above for detecting or quantifying captured target molecule. For example, post-translational modification of a captured target macromolecule can be analyzed by, for instance, an ELISA method. In particular, phosphorylation of a captured target macromolecule can be analyzed with antibodies specific for phosphotyrosine or

phosphoserine. Glycosylation of a captured target macromolecule can be analyzed with lectins such as concanavalin A or wheat germ agglutinin. Other features of a captured target molecule can be analyzed using any of the techniques described above or any other technique known to those of skill in the art.

5 A target molecule can be isolated by capturing the target molecule with a surface imprint and then recovering the target molecule from the imprint. The target molecule can be recovered from the imprint by diffusion or by incubation in urea, guanidine, SDS, or other techniques known to those of skill in the art for disrupting macromolecular complexes or for denaturing molecules.

10

5.10 Methods of screening molecules

In another aspect, the present invention is drawn to methods of screening molecules. This aspect of the invention encompasses screening both molecules of determined structure and screening of those of undetermined structure. To screen a
15 plurality of molecules, the plurality is contacted with a plurality imprints. In one embodiment, a substrate comprises a plurality of imprints. In another embodiment, a plurality of substrates comprises a plurality of imprints.

At least one imprint of the plurality is a surface imprint of a template molecule that does not necessarily correspond to any portion of a known molecule as
20 defined above. If the molecules to be screened are polypeptides, the template molecule should be a peptide or a polysaccharide. If the molecules to be screened are polynucleotides, the template molecule should be a polynucleotide. If the molecules to be screened are polysaccharides, the template molecule should be a polysaccharide. If the molecules to be screened are a mixture of different classes of molecules, the plurality of
25 imprints can comprise imprints of template molecules of the corresponding classes.

A sample containing a plurality of molecules is contacted with the plurality of imprints. If any molecule of the sample contains a structure that corresponds sufficiently to the structure of the template molecule, the molecule will be captured by the plurality of imprints. Any molecules captured can be quantified or recovered from the imprint. Since
30 template molecules can have structures that do not correspond to any portion of the structure of any known molecule, the present method of screening can be used to capture, isolate, and identify novel molecules from complex samples.

35

6. EXAMPLE 1: Preparation of a conjugate molecule comprising a template molecule corresponding to the carboxy-terminus of cytochrome c and a palmitic acid tail molecule

To create a surface imprint capable of binding the protein cytochrome c, a conjugate molecule corresponding in structure to the seven carboxy-terminal amino acids of cytochrome c was constructed. A template molecule was first designed having the amino acid sequence of the seven carboxy-terminal amino acids of the horse heart cytochrome c polypeptide, LKKATNE. A seven amino acid sequence should be sufficiently unique to provide a surface imprint with specificity for cytochrome c. A peptide with the sequence LKKATNE was synthesized by standard techniques.

A conjugate molecule was then prepared with the LKKATNE template molecule. Since LKKATNE is a hydrophilic template molecule (see Kyte & Doolittle (1982), J. Mol. Biol. 157:105-132), palmitic acid was chosen as a hydrophobic tail molecule. Palmitic acid was linked to the amino-terminus of the LKKATNE via an amide bond to form a palmitoyl-peptide conjugate molecule.

7. EXAMPLE 2: Preparation of an acrylamide surface imprint capable of binding cytochrome c

In this example, we demonstrate the preparation of an acrylamide surface imprint capable of binding cytochrome c. The surface imprint is prepared in a two-phase system with the conjugate molecule of Example 3 whose structure corresponds to the amino acid sequence of the carboxy-terminus of cytochrome c. The conjugate molecule, with a hydrophilic template molecule linked to a hydrophobic tail molecule, was designed to partition to the interface of the two-phase system.

Acrylamide monomer solution was prepared by dissolving 28.5 g acrylamide and 1.5 g N-N'-methylene bisacrylamide in 100 ml of 4 M urea. 2 mg of the palmitoyl-peptide conjugate molecule of Example 1 was dissolved in 1 ml of the acrylamide monomer solution. Ammonium persulfate and TEMED were added to the solution as catalysts. The final concentration of ammonium persulfate was 0.02 %, and the final concentration of TEMED was 0.1 %. 0.5 ml light mineral oil was added, and the mixture was sonicated at 60 watts for 10 min. The resulting suspension was centrifuged at 5,000xg for 10 minutes to separate phases. After polymerization at room temperature, the mineral oil phase was removed and the polymer was washed with 10 mM Tris-HCl, pH 9.0, containing 4 M urea and 10 % SDS for 24 h. The resulting matrix had the form of the interior of an Eppendorf tube.

A control polymer was prepared by the same protocol using a control conjugate molecule prepared with a control template molecule corresponding to a portion of rabbit skeletal muscle myosin heavy chain. The amino acid sequence of the control template molecule, TKVISEE, is not found in the primary amino acid sequence of horse heart cytochrome c. A palmitic acid tail molecule was linked to the amino terminus of the control template molecule via an amide bond to generate the control conjugate molecule.

8. EXAMPLE 3: Capture of cytochrome c with a polyacrylamide surface imprint of its C-terminal sequence

In this example we demonstrate that the acrylamide surface imprint prepared in Example 2 with a seven amino acid template molecule selectively binds the full-length cytochrome c protein.

A 100 μ l solution of 0.1 mg/ml bovine serum albumin, 0.1 mg/ml trypsin inhibitor, and 0.1 mg/ml cytochrome c (see FIG. 6, lane 1) in MES/urea buffer (10 mM MES, pH 5.0, and 4 M urea) was incubated with approximately 0.5 cm² surface imprint of Example 2 at room temperature for 4 h. A 100 μ l sample of the same protein solution was also incubated with a control polymer prepared according to the protocol of Example 2 with the control conjugate molecule corresponding to rabbit myosin heavy chain (see FIG. 6, lanes 3 and 5). The supernatant was removed (see FIG. 6, lanes 2 and 3) and the surface imprint was washed twice with 500 ml MES/urea buffer for 15 min each. Proteins were eluted by washing overnight with 10 % SDS in MES/urea buffer (see FIG. 6, lanes 4 and 5).

The supernatant from the surface imprint incubation (see FIG. 6, lane 2) shows significantly more cytochrome c bound the surface imprint compared to the amount bound by the control polymer (see FIG. 6, lane 3). Washing with MES/urea buffer removed non-specifically bound proteins from the surface imprint and from the control polymer. Elution overnight with 10% SDS removed a fraction of the cytochrome c specifically bound to the surface imprint (see FIG. 6, lane 4) and some non-specifically bound BSA (see FIG. 6, lanes 4 and 5).

This example demonstrates that the surface imprints of the present invention can be used to specifically capture and isolate a protein from a mixture of proteins. This example also demonstrates that the capture of cytochrome c depends on the structure of the template molecule. The control polymer imprinted with a template molecule that has no correspondence to cytochrome c showed no specific binding of cytochrome c (see FIG. 6, lane 5).

35

9. EXAMPLE 4: Preparation of a second surface imprint of the C-terminal sequence of cytochrome c

In this example, we demonstrate the preparation of a second acrylamide surface imprint capable of binding cytochrome c. The surface imprint is prepared in a two-phase system with the conjugate molecule of Example 1 whose structure corresponds to the amino acid sequence of the carboxy-terminus of cytochrome c. The conjugate molecule, with a hydrophilic template molecule linked to a hydrophobic tail molecule, was designed to partition to the interface of the two-phase system.

Acrylamide monomer solution was prepared by dissolving 28.5 g acrylamide and 1.5 g N-N'-methylene bisacrylamide in 100 ml of 4 M urea. 2 mg of the palmitoyl-peptide conjugate molecule of Example 1 was dissolved in 1 ml of the acrylamide monomer solution. Ammonium persulfate and TEMED were added to the solution as catalysts. The final concentration of ammonium persulfate was 0.02 %, and the final concentration of TEMED was 0.1 %. 0.5 ml light mineral oil was added, and the mixture was sonicated at 60 watts for 4 min. The resulting suspension was centrifuged at 5,000xg for 10 minutes to separate phases. After polymerization at room temperature, the mineral oil phase was removed and the polymer was washed with 10 mM Tris-HCl, pH 9.0, containing 4 M urea and 10 % SDS for 24 h. The resulting matrix was ground into beads approximately 0.1 mm in diameter.

10. EXAMPLE 5: Capture of cytochrome c with a polyacrylamide surface imprint of its C-terminal sequence

In this example we demonstrate that the acrylamide surface imprint prepared in Example 4 with a seven amino acid template molecule selectively binds the full-length cytochrome c protein.

A 100 μ l solution of 0.1 mg/ml bovine serum albumin, 0.1 mg/ml trypsin inhibitor, and 0.1 mg/ml cytochrome c (see FIG. 7, lane 1) in MES/urea buffer (10 mM MES, pH 5.0, and 4 M urea) was incubated with approximately 1.5 cm² surface imprint of Example 4 at room temperature for 4 h. A 100 μ l sample of the same protein solution was also incubated with a control polymer prepared according to the protocol of Example 4 with no conjugate molecule (see FIG. 7, lanes 1 and 3). The supernatant was removed (see FIG. 7, lanes 1 and 2) and the surface imprint was washed twice with 500 ml MES/urea buffer for 15 min each. Proteins were eluted by washing overnight with 10 % SDS in MES/urea buffer (see FIG. 7, lanes 3 and 4).

The supernatant from the surface imprint incubation (see FIG. 7, lane 2) shows significantly more cytochrome c bound the surface imprint compared to the amount bound by the control polymer (see FIG. 7, lane 1). Washing with MES/urea buffer removed non-specifically bound proteins from the surface imprint and from the control
5 polymer. Elution overnight with 10% SDS removed a significant fraction of the cytochrome c specifically bound to the surface imprint (see FIG. 7, lane 4) and some non-specifically bound BSA (see FIG. 7, lanes 3 and 4).

This example further demonstrates that the surface imprints of the present invention can be used to specifically capture and isolate a protein from a mixture of
10 proteins.

11. EXAMPLE 6: Capture of cytochrome c from a cell lysate with a polyacrylamide surface imprint of its C-terminal sequence

In this example we demonstrate that the acrylamide surface imprint prepared
15 in Example 4 with a seven amino acid template molecule selectively binds the full-length cytochrome c protein.

A 100 μ l solution of a cell lysate (1 mg total protein from rat pheochromocytoma cells) spiked with 0.1 mg/ml cytochrome c in MES/urea buffer (10 mM MES, pH 5.0, and 4 M urea) was incubated with approximately 1.5 cm² surface imprint of
20 Example 4 at room temperature for 4 h. A 100 μ l sample of the same protein solution was also incubated with a control polymer prepared according to the protocol of Example 4 with no conjugate molecule (see FIG. 7, lanes 5 and 7). The supernatant was removed (see FIG. 7, lanes 5 and 6) and the surface imprint was washed twice with 500 ml MES/urea buffer for 15 min each. Proteins were eluted by washing overnight with 10 % SDS in MES/urea
25 buffer (see FIG. 7, lanes 7 and 8).

The supernatants from both surface imprint compositions showed that most proteins of the cell lysate did not bind the compositions (see FIG. 7, lanes 5 and 6). Washing with MES/urea buffer removed non-specifically bound proteins from the surface imprint and from the control polymer. Elution overnight with 10% SDS removed a fraction
30 of the cytochrome c specifically bound to the surface imprint (see FIG. 7, lane 8). The control imprint did not specifically bind cytochrome c (see FIG. 7, lane 7).

This example demonstrates the powerful specificity of the surface imprints of the present invention. The surface imprint of the carboxy-terminus selectively bound cytochrome c from a complex cell lysate. Surface imprints of the present invention can be
35

used to capture and isolate specific molecules from the most complex mixtures of biological molecules.

5 **12. EXAMPLE 7: Preparation of a conjugate molecule comprising a template molecule corresponding to the carboxy-terminus of myoglobin and a C₁₆ aliphatic chain**

To create a surface imprint capable of binding myoglobin, a conjugate molecule corresponding in structure to the seven carboxy-terminal amino acids of myoglobin was constructed. A template molecule was first designed having the amino acid
10 sequence of the seven carboxy-terminal amino acids of the horse heart myoglobin polypeptide, KELGFQG. A seven amino acid sequence should be sufficiently unique to provide a surface imprint with specificity for myoglobin. A peptide with the sequence KELGFQG was synthesized by standard techniques.

A conjugate molecule was then prepared with the KELGFQG template
15 molecule. Since KELGFQG is a hydrophilic template molecule (see Kyte & Doolittle (1982), J. Mol. Biol. 157:105-132), palmitic acid was chosen as a hydrophobic conjugate molecule. Palmitic acid was linked to the amino-terminus of the KELGFQG via an amide bond to form a palmitoyl-peptide conjugate molecule.

20 **13. EXAMPLE 8: Preparation of an acrylamide surface imprint capable of binding myoglobin**

In this example, we demonstrate the preparation of an acrylamide surface imprint capable of binding myoglobin. The surface imprint is prepared in a two-phase system with the conjugate molecule of Example 7 whose structure corresponds to the amino
25 acid sequence of the carboxy-terminus of myoglobin. The conjugate molecule, with a hydrophilic template molecule linked to a hydrophobic tail molecule, was designed to partition to the interface of the two-phase system.

Acrylamide monomer solution was prepared by dissolving 28.5 g acrylamide and 1.5 g N-N'-methylene bisacrylamide in 100 ml of 4 M urea. 2 mg of the palmitoyl-
30 peptide conjugate molecule of Example 7 was dissolved in 1 ml of the acrylamide monomer solution. Ammonium persulfate and TEMED were added to the solution as catalysts. The final concentration of ammonium persulfate was 0.02 %, and the final concentration of TEMED was 0.1 %. 0.5 ml light mineral oil was added, and the mixture was sonicated at 60 watts for 10 min. The resulting suspension was centrifuged at 5,000xg for 10 minutes to
35 separate phases. After polymerization at room temperature, the mineral oil phase was

removed and the polymer was washed with 10 mM Tris-HCl, pH 9.0, containing 4 M urea and 10 % SDS for 24 h. The resulting matrix was ground into irregular beads.

A control polymer was prepared by imprinting a template peptide with the sequence LKKATNE as described in Example 2, supra.

5

14. **EXAMPLE 9: Capture of myoglobin with a polyacrylamide surface imprint of its C-terminal sequence**

In this example we demonstrate that the acrylamide surface imprint prepared in Example 8 with a seven amino acid template molecule selectively binds the full-length
10 myoglobin protein.

A 100 μ l solution of a cell lysate (1 mg total protein from rat pheochromocytoma cells) spiked with 10 μ g myoglobin in MES/urea buffer (10 mM MES, pH 5.0, and 4 M urea) was incubated with approximately 1.5 cm² surface imprint of Example 8 at room temperature for 4 h. A 100 μ l sample of the same protein solution was
15 also incubated with a control polymer prepared according to the protocol of Example 8 (see FIG. 8, lanes 2, 4 and 6). The supernatant was removed (see FIG. 8, lanes 2 and 3) and the surface imprint was washed twice with 500 ml MES/urea buffer for 15 min each (see FIG. 8, lanes 4 and 5). Proteins were eluted by washing overnight with 10 % SDS in MES/urea buffer (see FIG. 8, lanes 6 and 7).

20 The supernatants from both surface imprint compositions showed that most proteins of the cell lysate did not bind the compositions (see FIG. 8, lanes 2 and 3). Washing with MES/urea buffer removed non-specifically bound proteins from the surface imprint and from the control polymer (see FIG. 8, lanes 4 and 5). Elution overnight with 10% SDS removed a fraction of the myoglobin specifically bound to the surface imprint
25 (see FIG. 8, lane 7). The control imprint did not specifically bind myoglobin (see FIG. 8, lane 6).

This example demonstrates the powerful specificity of the surface imprints of the present invention. The surface imprint of the carboxy-terminus selectively bound myoglobin from a complex cell lysate. Surface imprints of the present invention can be
30 used to capture and isolate specific molecules from the most complex mixtures of biological molecules.

35

15. EXAMPLE 10: Preparation of a conjugate molecule comprising a template molecule corresponding to the carboxy-terminus of trypsin inhibitor and a C₁₆ aliphatic chain

To create a surface imprint capable of binding trypsin inhibitor, a conjugate molecule corresponding in structure to the seven carboxy-terminal amino acids of trypsin inhibitor was constructed. A template molecule was first designed having the amino acid sequence of the seven carboxy-terminal amino acids of the soybean trypsin inhibitor polypeptide, KLDKESL. A seven amino acid sequence should be sufficiently unique to provide a surface imprint with specificity for trypsin inhibitor. A peptide with the sequence KLDKESL was synthesized by standard techniques.

A conjugate molecule was then prepared with the KLDKESL template molecule. Since KLDKESL is a hydrophilic template molecule (see Kyte & Doolittle (1982), J. Mol. Biol. 157:105-132), palmitic acid was chosen as a hydrophobic conjugate molecule. Palmitic acid was linked to the amino-terminus of the KLDKESL via an amide bond to form a palmitoyl-peptide conjugate molecule.

16. EXAMPLE 11: Preparation of an acrylamide surface imprint capable of binding trypsin inhibitor

In this example, we demonstrate the preparation of an acrylamide surface imprint capable of binding trypsin inhibitor. The surface imprint is prepared in a two-phase system with the conjugate molecule of Example 10 whose structure corresponds to the amino acid sequence of the carboxy-terminus of trypsin inhibitor. The conjugate molecule, with a hydrophilic template molecule linked to a hydrophobic tail molecule, was designed to partition to the interface of the two-phase system.

Acrylamide monomer solution was prepared by dissolving 28.5 g acrylamide and 1.5 g N-N'-methylene bisacrylamide and 24 g urea in 100 ml of water. 2 mg of the palmitoyl-peptide conjugate molecule of Example 10 was dissolved in 1 ml of the acrylamide monomer solution. Ammonium persulfate and TEMED were added to the solution as catalysts. The final concentration of ammonium persulfate was 0.02 %, and the final concentration of TEMED was 0.1 %. 0.5 ml light mineral oil was added, and the mixture was sonicated at 60 watts for 10 min. The resulting suspension was centrifuged at 5,000xg for 10 minutes to separate phases. After polymerization at room temperature, the mineral oil phase was removed and the polymer was washed with 10 mM Tris-HCl, pH 9.0, containing 4 M urea and 10 % SDS for 24 h. The resulting matrix had the form of the interior of an Eppendorf tube.

A control polymer was prepared by the same protocol using a control conjugate molecule prepared with a control template molecule corresponding to a portion of rabbit muscle phosphorylase b. The amino acid sequence of the control template molecule, APDEKIP, is not found in the primary amino acid sequence of trypsin inhibitor. A palmitic acid tail molecule was linked to the amino terminus of the control template molecule via an amide bond to generate the control conjugate molecule. A second control polymer was also prepared by following the same protocol with no conjugate molecule.

17. EXAMPLE 12: Capture of trypsin inhibitor with a polyacrylamide surface imprint of its C-terminal sequence

In this example we demonstrate that the acrylamide surface imprint prepared in Example 11 with a seven amino acid template molecule selectively binds the full-length trypsin inhibitor protein.

A 100 μ l solution of 0.1 mg/ml bovine serum albumin, 0.1 mg/ml trypsin inhibitor, and 0.1 mg/ml cytochrome c (see FIG. 9, lane 1) in MES/urea buffer (10 mM MES, pH 5.0, and 4 M urea) was incubated with approximately 0.5 cm² surface imprint of Example 11 at room temperature for 4 h. A 100 μ l sample of the same protein solution was also incubated with control polymers prepared according to the protocol of Example 11 with either no conjugate molecule (see FIG. 9, lanes 2 and 4) or the control conjugate molecule based on the carboxy terminus of phosphorylase b (see FIG. 9, lanes 4 and 7). The supernatant was removed (see FIG. 9, lanes 2, 3 and 4) and the surface imprint was washed twice with 500 ml MES/urea buffer for 15 min each. Proteins were eluted by washing overnight with 10 % SDS in MES/urea buffer (see FIG. 9, lanes 5, 6 and 7).

The supernatant from the surface imprint incubation (see FIG. 9, lane 3) shows significantly more trypsin inhibitor bound the surface imprint compared to the amount bound by the control polymers (see FIG. 9, lanes 2 and 4). Washing with MES/urea buffer removed non-specifically bound proteins from the surface imprint and from the control polymer. Elution overnight with 10% SDS removed a fraction of the trypsin inhibitor specifically bound to the surface imprint (see FIG. 9, lane 6). Trypsin inhibitor was not significantly bound by the control polymers (see FIG. 9, lanes 5 and 7).

This example demonstrates that the surface imprints of the present invention can be used to specifically capture and isolate a protein from a mixture of proteins. This example also demonstrates that the capture of trypsin inhibitor depends on the structure of the template molecule. The control polymer imprinted with a template molecule that has no

35

correspondence to trypsin inhibitor showed no specific binding of cytochrome c (see FIG. 9, lane 7).

5 The present invention is not to be limited in scope by the exemplified
embodiments, which are intended as illustrations of single aspects of the invention, and any
compositions and methods which are functionally equivalent are within the scope of the
invention. Indeed, various modifications of the invention in addition to those described
above will become apparent to those skilled in the art from the foregoing description and
10 accompanying drawings. Such modifications are intended to fall within the scope of the
appended claims.

All references cited herein are hereby incorporated by reference in their
entirety.

15

20

25

30

35

CLAIMS

What is claimed is:

- 5 1. A surface imprint composition comprising a matrix material defining imprint
cavities of a template molecule wherein a substantial fraction of the imprint cavities are
localized at or near the surface of the matrix material.
- 10 2. The surface imprint of Claim 1 in which the matrix material comprises a
polymer.
- 15 3. The surface imprint of Claim 2, wherein the polymer comprises a
polymerized monomer selected from the group consisting of styrene, methyl methacrylate,
2-hydroxyethyl methacrylate, 2-hydroxyethyl acrylate, methyl acrylate, acrylamide, vinyl
ether, vinyl acetate, divinylbenzene, ethylene glycol dimethacrylate, ethylene glycol
diacrylate, pentaerythritol dimethacrylate, pentaerythritol diacrylate,
N,N'-methylenebisacrylamide, N,N'-ethylenebisacrylamide,
N,N'-(1,2-dihydroxyethylene)bis-acrylamide, trimethylolpropane trimethacrylate and vinyl
cyclodextrin.
- 20 4. The surface imprint of Claim 1 in which the matrix material comprises a
heat-sensitive compound.
- 25 5. The surface imprint of Claim 4, wherein the heat-sensitive compound is
selected from the group consisting of hydrogels, agarose, gelatins and moldable plastics.
6. The surface imprint composition of Claim 1, wherein the template molecule
corresponds to a portion of a macromolecule of interest.
- 30 7. The surface imprint composition of Claim 6 further including the
macromolecule bound at an imprint cavity.
8. The surface imprint composition of Claim 6, wherein the template molecule
corresponds to a terminal portion of the macromolecule.

35

9. The surface imprint composition of Claim 6, wherein the macromolecule is a polynucleotide and the template molecule is an oligonucleotide.
10. The surface imprint composition of Claim 6, wherein the macromolecule is a polypeptide and the template molecule is an oligosaccharide.
11. The surface imprint composition of Claim 6, wherein the macromolecule is a polypeptide and the template molecule is a peptide.
12. The surface imprint composition of Claim 10, wherein the sequence of the peptide corresponds to a contiguous sequence of the polypeptide.
13. The surface imprint composition of Claim 11, wherein the peptide is between 3 and 15 amino acids in length.
14. The surface imprint composition of Claim 11, wherein the peptide is between 4 and 15 amino acids in length.
15. The surface imprint composition of Claim 11, wherein the peptide is between 4 and 7 amino acids in length.
16. The surface imprint composition of Claim 11, wherein the portion of the polypeptide comprises the C-terminus of the polypeptide.
17. The surface imprint composition of Claim 1 in which the matrix material defines imprint cavities of at least two different template molecules.
18. The surface imprint composition of Claim 17 in which at least one of the template molecules corresponds to a portion of a macromolecule.
19. The surface imprint composition of Claim 17 in which cavities are arranged in a spatially identifiable array.
20. A plurality of surface imprint compositions according to Claim 1.

35

21. The plurality of surface imprint compositions of Claim 20 in which each surface imprint composition of the plurality is unique.

22. The plurality of surface imprint compositions of Claim 20 in which each
5 surface imprint composition comprises a plurality of different cavities.

23. The plurality of surface imprints of Claim 20 which are arranged in a spatially identifiable array.

10 24. The array of Claim 23 which is one-dimensional.

25. The array of Claim 23 which is two-dimensional.

26. The array of Claim 23 which is three-dimensional.
15

27. A surface imprint composition comprising a matrix material defining imprint cavities of a template molecule wherein a substantial fraction of the imprint cavities are oriented.

20 28. A method of preparing a surface imprint comprising the steps of:

(a) forming a hardened matrix in the presence of an immobilized template molecule; and

25 (b) removing the template molecule from the hardened matrix, yielding a surface imprint.

29. The method of Claim 28 wherein the matrix comprises a heat sensitive compound.
30

30. The method of Claim 28 wherein the matrix comprises a polymer.

31. The method of Claim 28 in which the immobilization is by way of covalent attachment.
35

32. The method of Claim 28 in which the template molecule is immobilized via a linker molecule.

33. The method of Claim 28 in which the template molecule is immobilized on a
5 solid support selected from the group consisting of glass, plastic and acrylic.

34. The method of Claim 28 in which the immobilized template molecule corresponds to a portion of the macromolecule of interest.

10 35. A method of making a surface imprint comprising the steps of:

(a) dispersing a polymerizable compound and a conjugate molecule in a solvent system which comprises a first solvent and a second solvent which is immiscible with the first solvent such that they form a two-phase system wherein the polymerizable
15 compound and the template moiety of the conjugate molecule partition into the same phase of the two-phase system;

(b) polymerizing the polymerizable compound; and

20 (c) removing the conjugate molecule.

36. The method of Claim 35 in which the template moiety and the tail moiety are linked via a linker.

25 37. The method of Claim 35 in which the tail moiety is hydrophobic and the template moiety is hydrophilic.

38. The method of Claim 35 in which the tail moiety is hydrophilic and the template moiety is hydrophobic.

30 39. The method of Claim 35 wherein the tail moiety comprises a lipid or palmitic acid.

40. The method of Claim 35 in which the conjugate is immobilized on a solid
35 support.

41. The method of Claim 40 in which the immobilization is by way of covalent attachment.
42. The method of Claim 41 in which the covalent attachment is via a linker
5 molecule.
43. The method of Claim 40 in which the tail moiety is covalently attached to the solid support.
- 10 44. The method of Claim 43 in which the covalent attachment is via a linker.
45. The method of Claim 43 in which the solid support is selected from the group consisting of glass, plastic and acrylic.
- 15 46. A method of capturing a molecule, comprising contacting the molecule with a surface imprint composition according to Claim 1 under conditions in which the molecule binds the surface imprint.
47. A method of capturing a macromolecule with a surface imprint composition
20 according to Claim 6.
48. A method of isolating a molecule, comprising the steps of:
(a) capturing the molecule according to Claim 46; and
(b) recovering the molecule from the imprint.
25
49. A method of capturing a plurality of molecules, comprising contacting the plurality of molecules with a surface imprint composition according to Claim 17, under conditions in which the molecules bind their corresponding surface imprint cavities.
- 30 50. A method of capturing a plurality of molecules, comprising contacting the plurality of molecules with a plurality of surface imprint compositions according to Claim 20, under conditions in which the molecules bind their corresponding surface imprints.
51. A method of quantifying the amount of a molecule in a sample, comprising
35 the steps of:

- (a) capturing the molecule according to Claim 46; and
- (b) quantifying the amount of the molecule bound to the surface imprint.

52. The method of Claim 51, in which the amount of the molecule is quantified
5 by fluorescence, resistance, capacitance, acoustic wave, or surface plasmon resonance.

53. A method of quantifying the relative amounts of a plurality of molecules in a sample, comprising the steps of:

- (a) capturing the plurality of molecules according to Claim 49 or 50;
- 10 (b) quantifying the amount of each molecule of the plurality bound to the plurality of surface imprints.

54. The method of Claim 53, in which the amount of a molecule is quantified by
fluorescence, resistance, capacitance, acoustic wave, or surface plasmon resonance.
15

55. A method of making an surface imprint array capable of capturing a plurality of different molecules, comprising the steps of:

- (a) forming a hardened matrix in the presence of an array of immobilized
template molecules; and
- 20 (b) removing at least two of the template molecules from the hardened matrix yielding a surface imprint array.

56. A method of screening a plurality of macromolecules, comprising contacting
the plurality of macromolecules with a matrix, said matrix comprising an surface imprint of
25 a template molecule wherein the template molecule is selected from a peptide consisting of 3 to 30 amino acids, a polynucleotide consisting of 3 to 30 nucleotides, and an oligosaccharide consisting of 3 to 30 saccharides, under conditions in which at least one molecule of the plurality binds the matrix.

30 57. A method of screening a plurality of macromolecules, comprising contacting the plurality of macromolecules with a plurality of matrices, said matrices comprising a plurality of surface imprints of template molecules, wherein at least two of the template molecules are unique, wherein the template molecules are selected from a peptide consisting of 3 to 30 amino acids, a polynucleotide consisting of 3 to 30 nucleotides, and an
35

oligosaccharide consisting of 3 to 30 saccharides, and under conditions in which at least one molecule of the plurality binds a matrix.

5

10

15

20

25

30

35

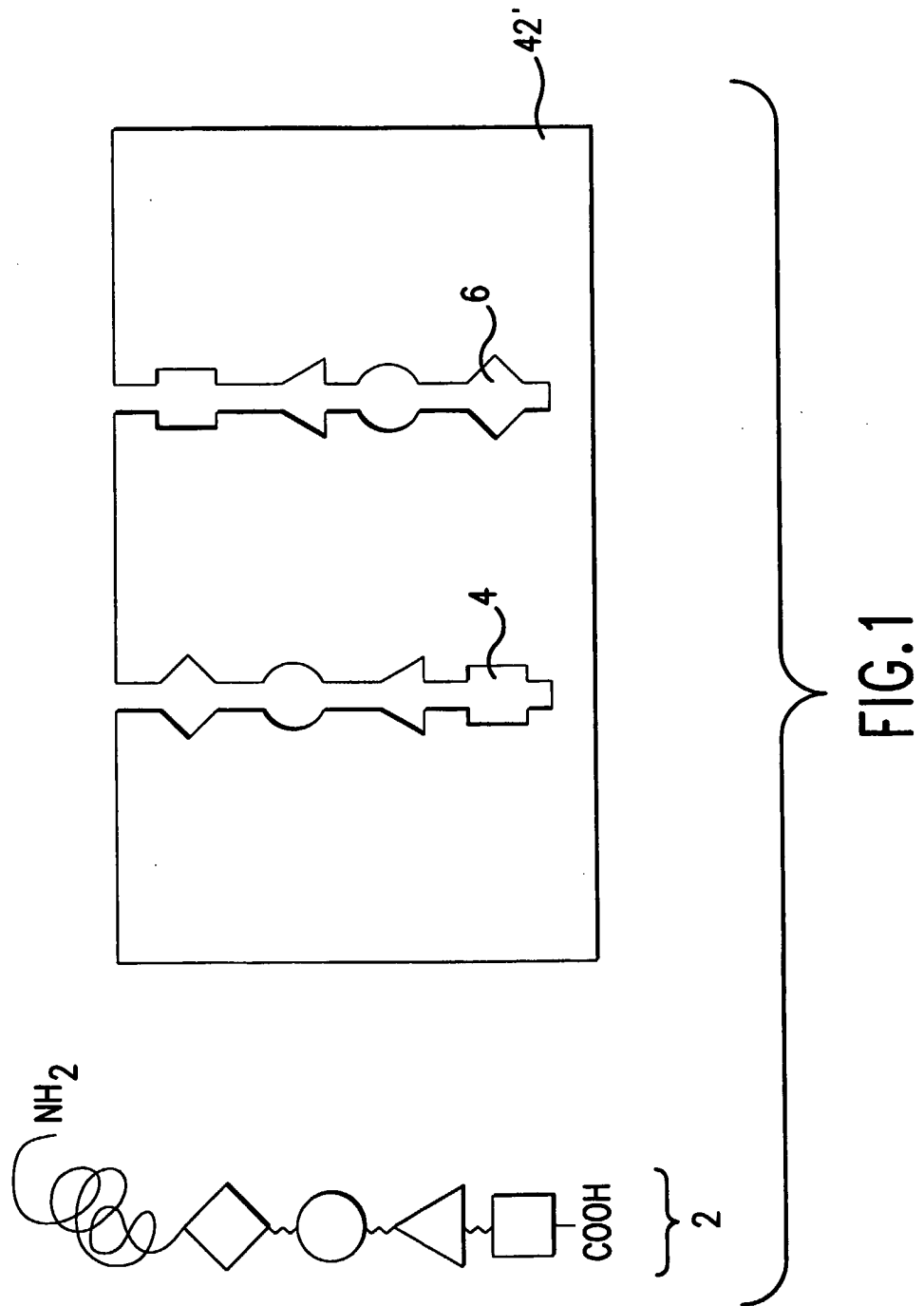

FIG. 1

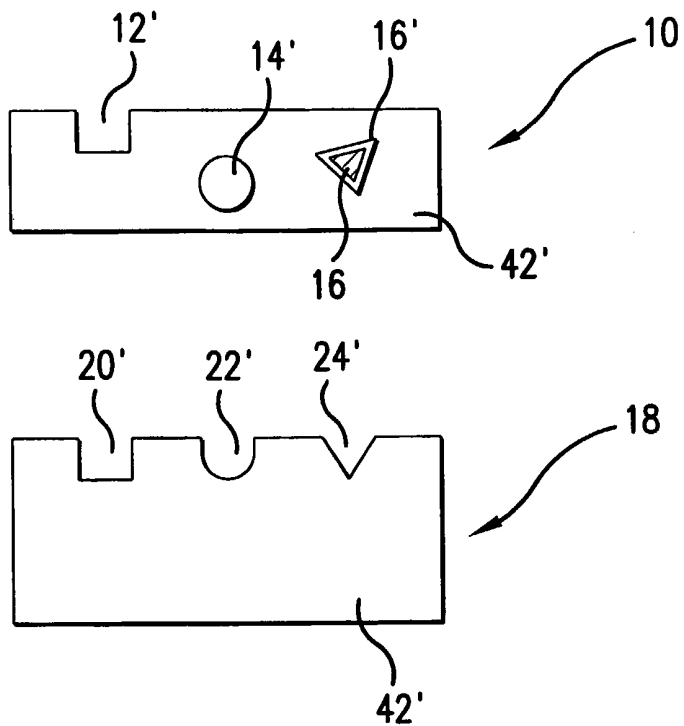

FIG.2

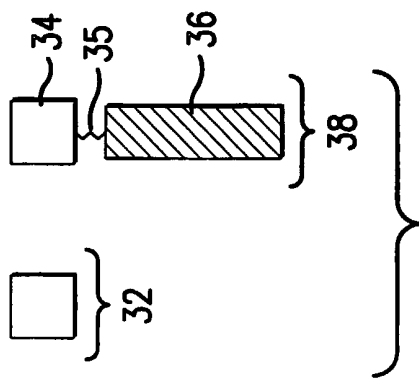

FIG. 3A

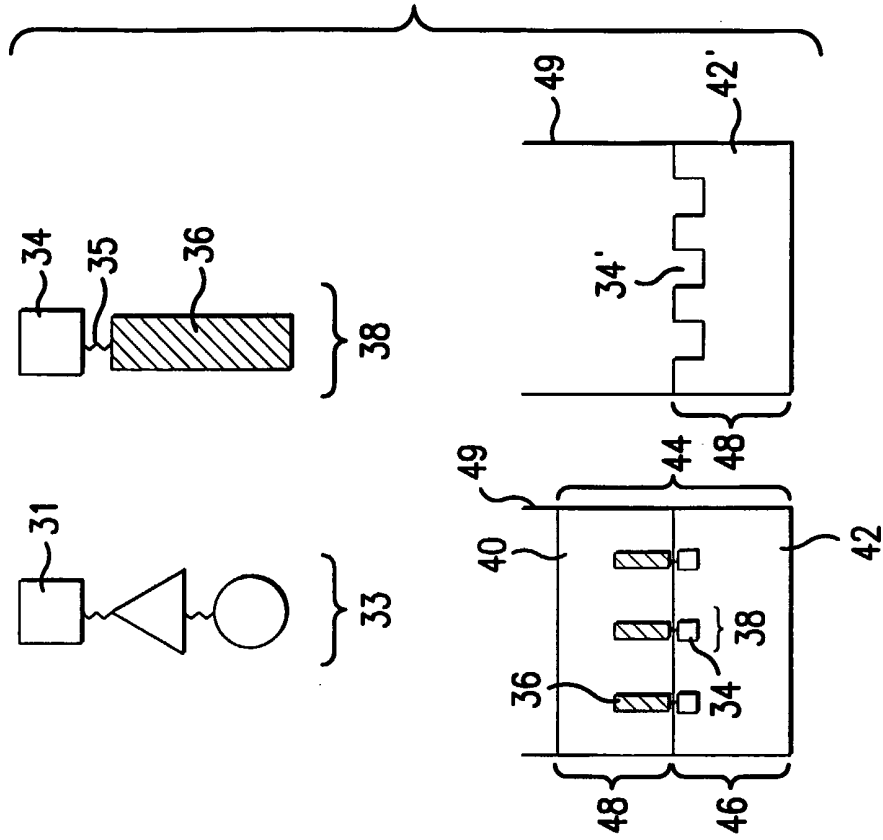

FIG. 3C

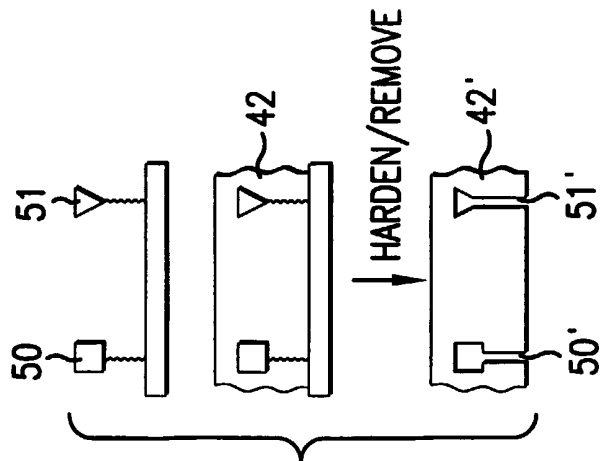

FIG. 3B

4/9

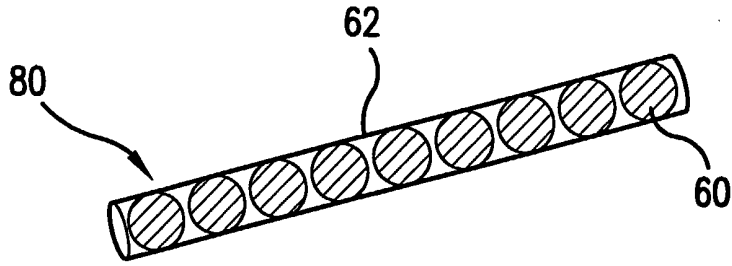

FIG. 4A

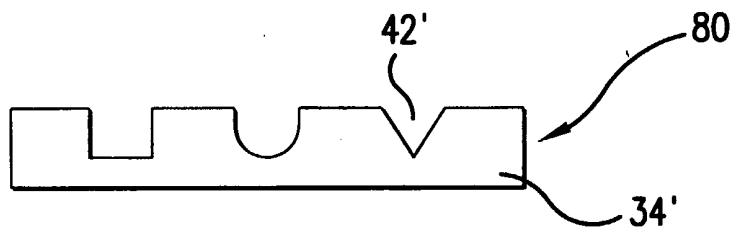

FIG. 4B

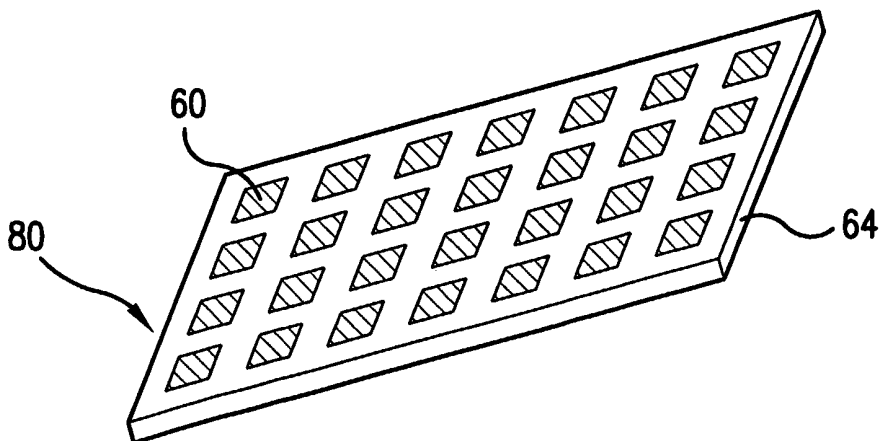

FIG. 4C

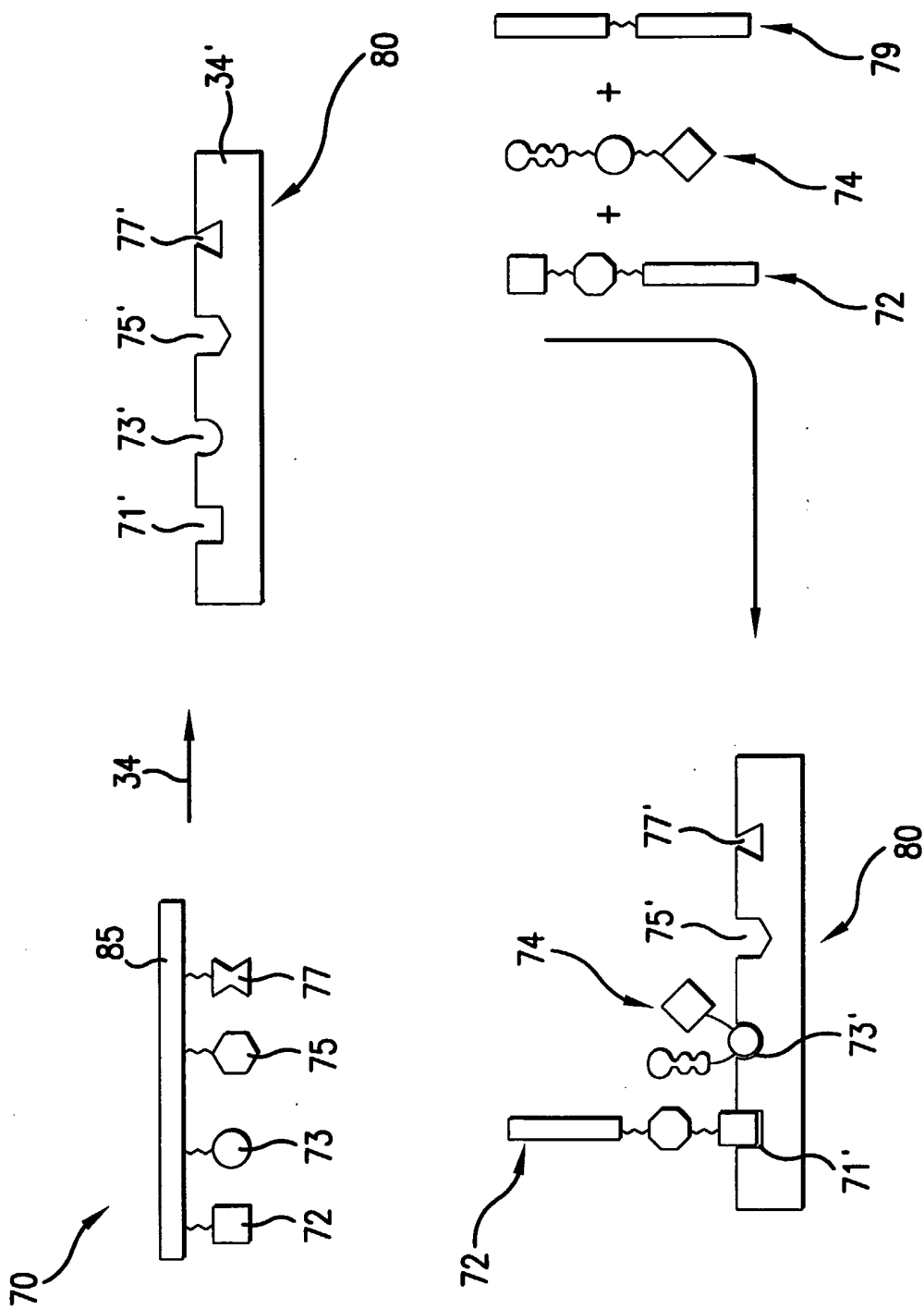

FIG. 5

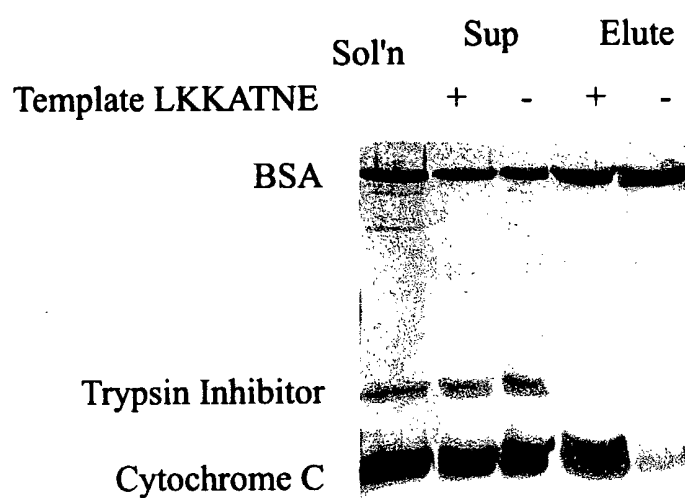

FIG. 6

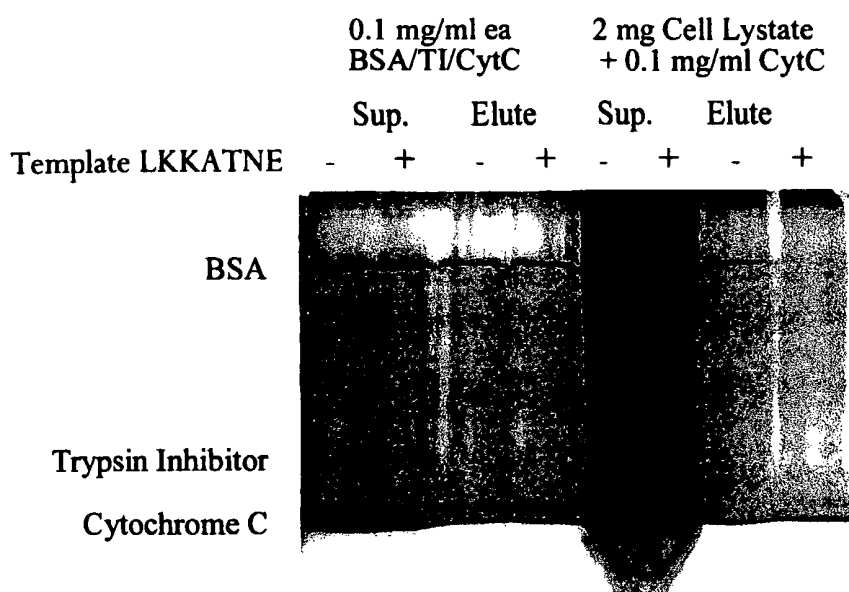

FIG.7

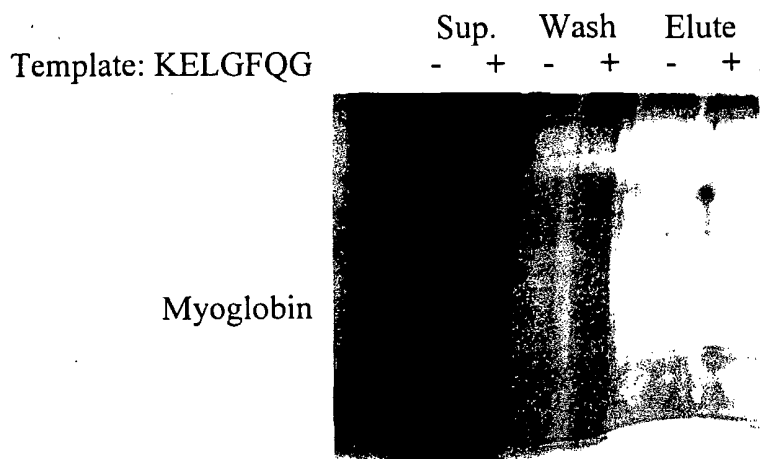

FIG.8

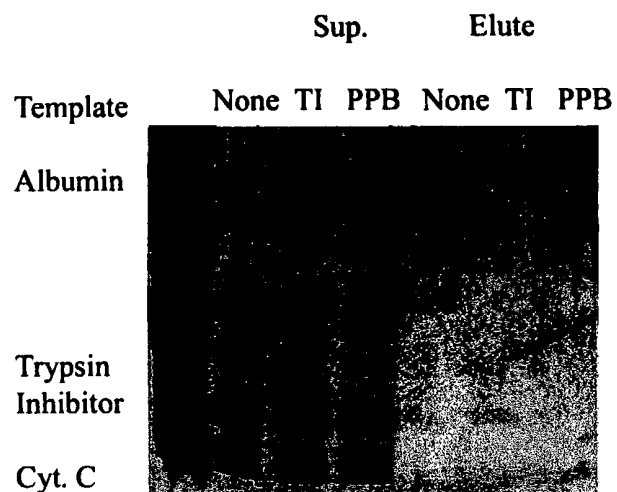

FIG.9

INTERNATIONAL SEARCH REPORT

International application No.

PCT/US01/05118

A. CLASSIFICATION OF SUBJECT MATTER

IPC(7) : G01N 33/566
 US CL : 436/501

According to International Patent Classification (IPC) or to both national classification and IPC

B. FIELDS SEARCHED

Minimum documentation searched (classification system followed by classification symbols)
 U.S. : 436/501; 435/7.1

Documentation searched other than minimum documentation to the extent that such documents are included in the fields searched

Electronic data base consulted during the international search (name of data base and, where practicable, search terms used)
 CAPLUS on STN (CAS Columbus, OH USA) molecular imprinting, template polymerization, hydrogel, oriented, surface, membrane, array

C. DOCUMENTS CONSIDERED TO BE RELEVANT

Category *	Citation of document, with indication, where appropriate, of the relevant passages	Relevant to claim No.
X --- Y	US 5,821,311 A (MOSBACH ET AL.) 13 October 1998 (13.10.1998), column 1, lines 49-61, column 6, lines 1-27, column 9, lines 4-27, and claims	1-4,20,21,35-39,46 ----- 5-19,22-34,40-45,47-57
X --- Y	US 5,110,833 A (MOSBACH) 05 May 1992 (05.05.1992), column 2, line 59-column 3, line 46, and column 5, lines 29-40	1-4,6-16,20,21,46-48,50,51,56,57 ----- 5,17-19,22-45,49,52-55
X --- Y	US 5,587,273 A (YAN ET AL.) 24 December 1996 (24.12.1996) column 1, lines 39-45, column 2, lines 57-62, column 8, and the claims.	1-3,20,21,23-25,28,30,46,51,52 ----- 4-19,22,26,27,29,31-45,47-50,53-57
X --- Y	KARMALKAR ET AL. Molecularly Imprinted Hydrogels Exhibit Chymotrypsin-like Activity, Macromolecules, March 1996, Vol 29 No. 4, pages 1366-1368. See entire document.	1-5,28-30,46 ----- 6-27,31-45,47-57

Further documents are listed in the continuation of Box C.

See patent family annex.

* Special categories of cited documents:		
"A" document defining the general state of the art which is not considered to be of particular relevance	"T"	later document published after the international filing date or priority date and not in conflict with the application but cited to understand the principle or theory underlying the invention
"E" earlier application or patent published on or after the international filing date	"X"	document of particular relevance; the claimed invention cannot be considered novel or cannot be considered to involve an inventive step when the document is taken alone
"L" document which may throw doubts on priority claim(s) or which is cited to establish the publication date of another citation or other special reason (as specified)	"Y"	document of particular relevance; the claimed invention cannot be considered to involve an inventive step when the document is combined with one or more other such documents, such combination being obvious to a person skilled in the art
"O" document referring to an oral disclosure, use, exhibition or other means		
"P" document published prior to the international filing date but later than the priority date claimed	"&"	document member of the same patent family

Date of the actual completion of the international search

14 April, 2001 (14.04.2001)

Date of mailing of the international search report

16 MAY 2001

Name and mailing address of the ISA/US
 Commissioner of Patents and Trademarks
 Box PCT
 Washington, D.C. 20231

Facsimile No. (703)305-3230

Authorized officer

Jyothsna Venkat

TERRY J. DEY
PARALEGAL SPECIALIST

Telephone No. (703) 308-TECHNOLOGY CENTER 1600

INTERNATIONAL SEARCH REPORT

Internat application No.

PCT/US01/05118

C (Continuation) DOCUMENTS CONSIDERED TO BE RELEVANT

Category*	Citation of document, with indication, where appropriate, of the relevant passages	Relevant to claim No.
X --- Y	US 5,310,648 A (ARNOLD ET AL.) 10 May, 1994 (10.05.1994), columns 3-5,7,8, and the claims	1-15,17,18,20-22,27-31,35-39,46-50,55-57 ----- 16,19,23-26,32-34,40-45,51-54

INTERNATIONAL SEARCH REPORT

International application No.

PCT/US01/05118

Box I Observations where certain claims were found unsearchable (Continuation of Item 1 of first sheet)

This international report has not been established in respect of certain claims under Article 17(2)(a) for the following reasons:

1. Claim Nos.:
because they relate to subject matter not required to be searched by this Authority, namely:

2. Claim Nos.:
because they relate to parts of the international application that do not comply with the prescribed requirements to such an extent that no meaningful international search can be carried out, specifically:

3. Claim Nos.:
because they are dependent claims and are not drafted in accordance with the second and third sentences of Rule 6.4(a).

Box II Observations where unity of invention is lacking (Continuation of Item 2 of first sheet)

This International Searching Authority found multiple inventions in this international application, as follows:
Please See Continuation Sheet

1. As all required additional search fees were timely paid by the applicant, this international search report covers all searchable claims.
2. As all searchable claims could be searched without effort justifying an additional fee, this Authority did not invite payment of any additional fee.
3. As only some of the required additional search fees were timely paid by the applicant, this international search report covers only those claims for which fees were paid, specifically claims Nos.:

4. No required additional search fees were timely paid by the applicant. Consequently, this international search report is restricted to the invention first mentioned in the claims; it is covered by claims Nos.:

- Remark on Protest**
- The additional search fees were accompanied by the applicant's protest.
- No protest accompanied the payment of additional search fees.

BOX II. OBSERVATIONS WHERE UNITY OF INVENTION IS LACKING This application contains the following inventions or groups of inventions which are not so linked as to form a single general inventive concept under PCT Rule 13.1. In order for all inventions to be examined, the appropriate additional examination fees must be paid.

Group I, claim(s) 1-26 and 46-54, drawn to compositions comprising a matrix material defining imprint cavities of a template molecule, arrays of such compositions, and methods of capturing, isolating, and quantifying molecules using the compositions.

Group II, claim(s) 27, drawn to a surface imprint composition with a substantial fraction of imprint cavities oriented.

Group III, claim(s) 28-34 and 55, drawn to a method of preparing a surface imprint composition.

Group IV, claim(s) 35-45, drawn to a method of preparing a surface imprint composition using a two-phase system.

Group VI, claim(s) 56 and 57, drawn to methods of screening a plurality of macromolecules.

The inventions listed as Groups I-V do not relate to a single general inventive concept under PCT Rule 13.1 because, under PCT Rule 13.2, they lack the same or corresponding special technical features for the following reasons: The groups share the common special technical feature of surface imprint compositions shown by Mosbach et al. (US 5,110,833) to lack novelty and does not make a contribution over the prior art. Mosbach et al. teach methods of making and use and compositions molecular imprinted polymers including compositions that bind to macromolecules which meet the specification requirements for "surface imprints."