

(12) UK Patent Application (19) GB (11) 2 278 445 (13) A

(43) Date of A Publication 30.11.1994

(21) Application No 9310233.3

(22) Date of Filing 18.05.1993

(71) Applicant(s)

Spirax-Sarco Limited

(Incorporated in the United Kingdom)

**130-132 St Georges Road, CHELTENHAM,
Gloucestershire, GL50 3EN, United Kingdom**

(72) Inventor(s)

Karel Svoboda

(74) Agent and/or Address for Service

Haseltine Lake & Co

**Hazlitt House, 28 Southampton Buildings, Chancery
Lane, LONDON, WC2A 1AT, United Kingdom**

(51) INT CL⁵

G01F 1/24 , G01D 5/22

(52) UK CL (Edition M)

**G1N NAEB N1A3A N1D7 N1D7A N7B1
U1S S2150**

(56) Documents Cited

GB 2068560 A US 4297899 A US 4210891 A

(58) Field of Search

**UK CL (Edition L) G1N NACDX NAEB
INT CL⁵ G01D 5/22 , G01F 1/24 1/26**

(54) Flow meters

(57) A fluid flow meter comprises a conduit 2 within which an orifice plate 8 is secured having an opening 10. An axially slidable contoured plug 12 provides a variable restriction to the size of the opening 10. The plug 12 is biased in the upstream direction by a spring 22 such that the position of the plug is responsive to the fluid flow rate in the conduit. The position of the plug is measured by a transducer 13 comprising a ferromagnetic shaft 18 which is attached to the plug and which has a semi-circular cross-section, the orientation of which varies along its length, and a fixed ferromagnetic sensor body 24. The sensor body has a primary coil 42 and secondary coils 38, 40, the induced voltages in which are dependent upon the axial position of the shaft 18 (and therefore the plug 12), and thus give an indication of the flow rate.

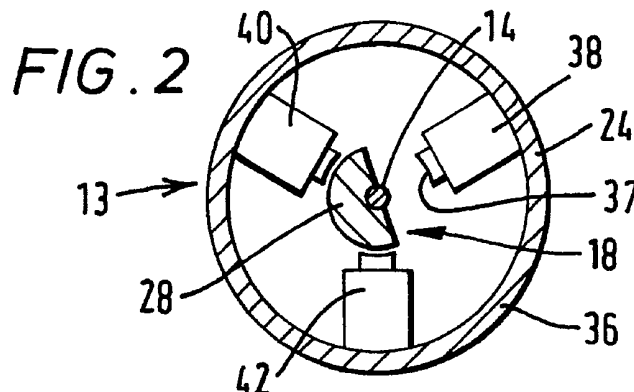
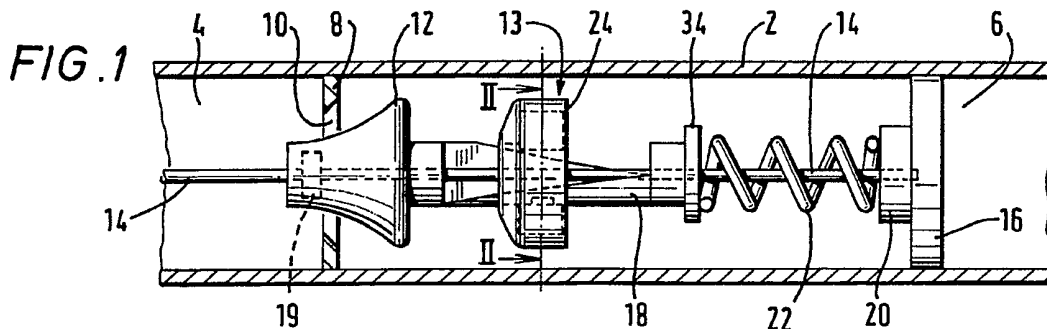

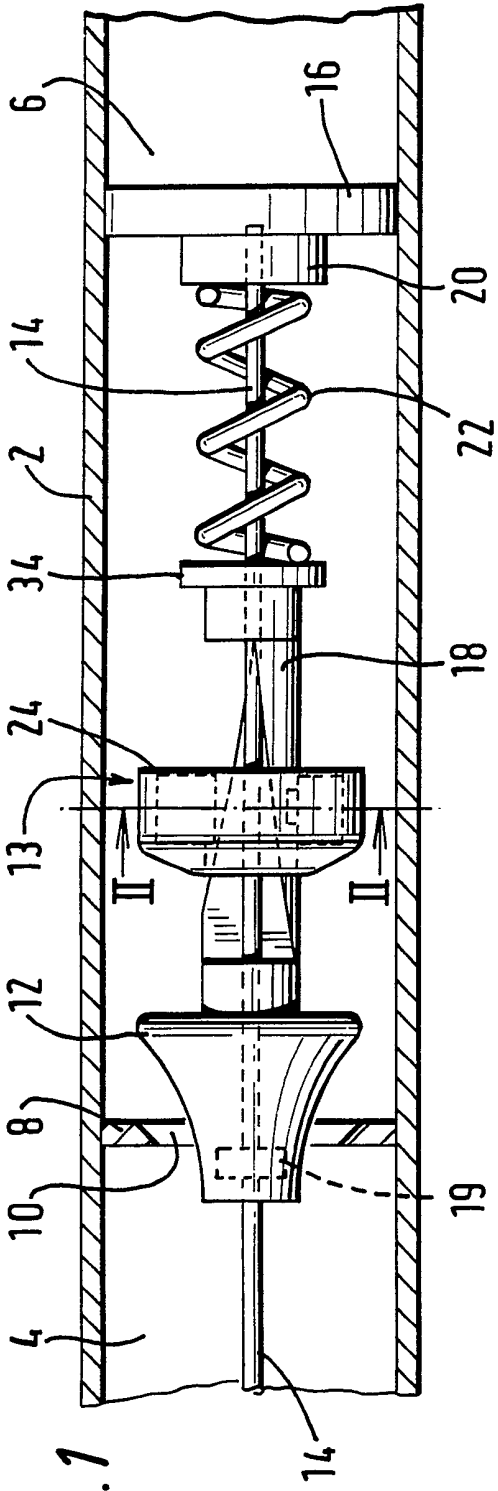

FIG. 1

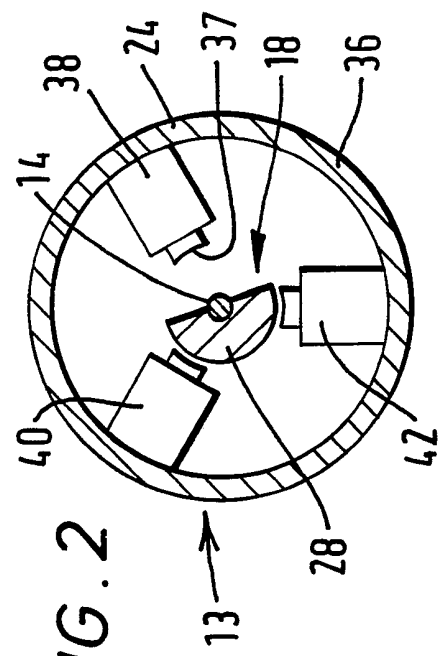

FIG. 2

FIG. 3

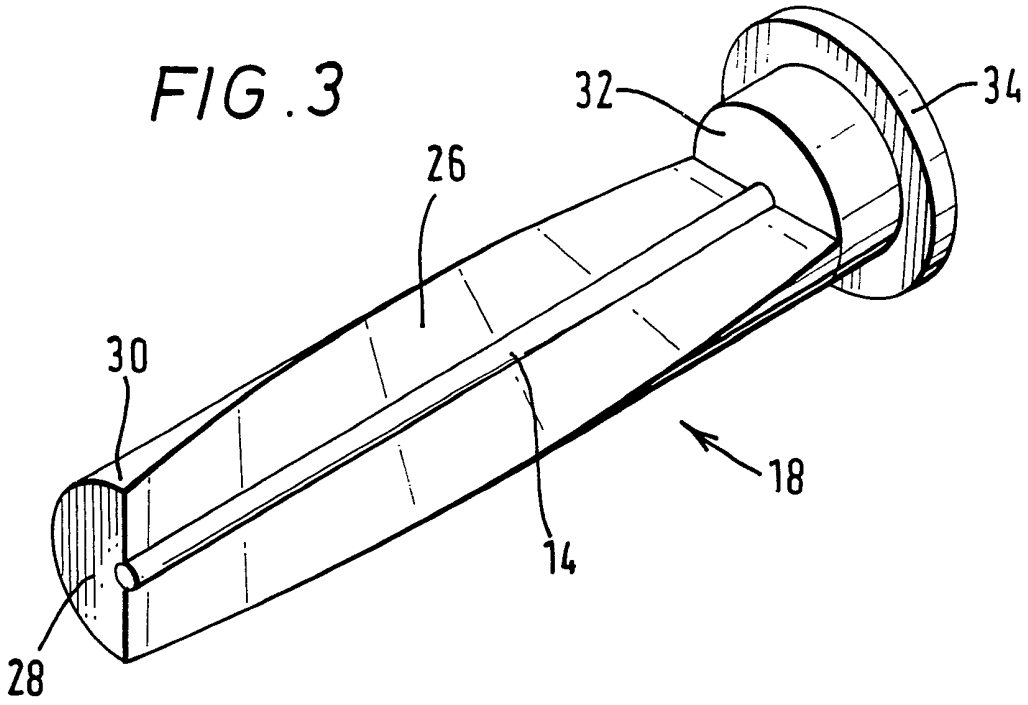

FIG. 4

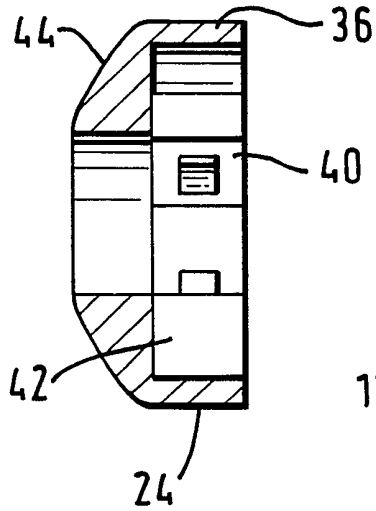
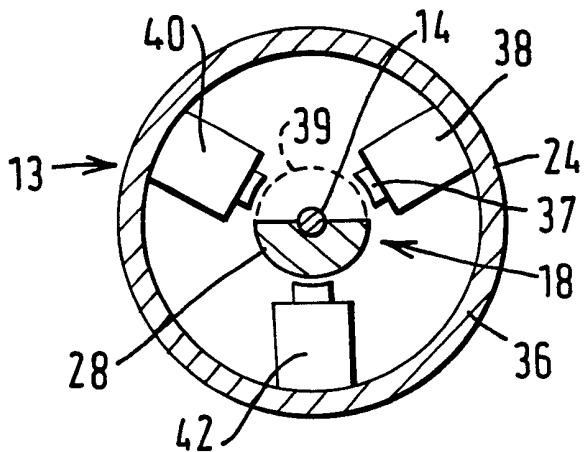

FIG. 5



FLOW METERS

This invention relates to flow meters.

GB 1566251 discloses a variable orifice flow meter. In this type of variable orifice flow meter a
5 flow body such as a contoured plug provides a variable closure to a fixed orifice. The plug is resiliently biased by a spring to close the orifice. The flow of fluid acts against the spring such that an increase in flow results in movement of the plug against the action
10 of the spring so as to cause an increase in the size of the variable orifice. As the plug movement is restrained by a spring, the differential pressure increases with flow rate. In conventional variable orifice meters of this type, the differential pressure
15 is the output signal, and consequently pressure tapplings and a pressure transducer are required.

According to the present invention there is provided a fluid flow meter comprising a flow body which is movable in a conduit for displacement by fluid
20 flowing in the conduit whereby the position of the flow body is dependent upon the fluid flow rate, a displacement transducer being provided which is responsive to displacement of the flow body and which comprises a ferromagnetic shaft and a ferromagnetic
25 sensor body which are linearly displaceable relatively to each other along an axis, the sensor body having a primary coil and a plurality of secondary coils, the coils being spaced apart from one another about the axis, the primary coil being coupled to each secondary
30 coil, through a separate magnetic path, each path including the shaft and the sensor body, the shaft being so configured that relative displacement between the shaft and the sensor body varies the magnetic coupling between the primary coil and the respective
35 secondary coils thereby to provide an output signal that is dependent upon the relative positions of the

shaft and the sensor body.

Thus the output signal of the transducer represents the position of the flow body, and consequently the flow rate through the duct.

5 Preferably, the sensor body comprises an annular member having ferromagnetic cores which project radially inwardly and about which the coils are mounted. In a preferred embodiment there is a primary coil and there are two secondary coils, the three coils
10 being equally angularly spaced from one another about the shaft.

The shaft may have a helical configuration and may have semi-circular cross-section. Thus, the cross-section of the shaft may comprise a semi-circle which
15 is disposed at varying angular positions along its length.

The flow body may comprise a cone which is disposed within an orifice.

For a better understanding of the present
20 invention and to show how it may be carried into effect reference will now be made by way of example to the accompanying drawings, in which:

Figure 1 shows a fluid flow meter;

Figure 2 is a sectional view, taken on the line
25 II-II in Figure 1, of a displacement transducer of the flow meter;

Figure 3 shows a component of the transducer;

Figure 4 shows, in longitudinal cross-section, another component of the transducer; and

30 Figure 5 corresponds to Figure 2 but shows the transducer under different flow conditions.

The flow meter shown in Figure 1 comprises a conduit 2 having an inlet 4 and an outlet 6. An orifice plate 8 is secured within the conduit 2 and has
35 an opening 10. An axially slidable cone shaped plug 12 provides a variable restriction to the sides of the

opening 10. The plug 12 is slidable along a guide 14 which is secured to the conduit 2 by supporting members 16, only one of which is shown in Figure 1. The plug 12 is connected to a displacement transducer 13. Means 5 19 is provided for preventing rotation of the plug 12 on the guide 14. This means may be an anti-rotation pin or slot. The plug 12 is biased in the upstream direction by a spring 22 which reacts against an abutment 20.

10 The transducer 13 comprises a ferromagnetic shaft 18 and a ferromagnetic sensor body 24. The shaft 18 is secured to the plug 12 and extends from it in the downstream direction. The sensor body 24 is in the form of a ring and surrounds the shaft 18. The shaft 15 18 is shown in greater detail in Figure 3. The shaft comprises an elongate body 26 having a semi-circular transverse cross-section 28. Between an upstream end 30 and a downstream end 32 of the body 26 there is a relative twisting of 90°. Thus, at each point along 20 the length of the body 26, there is a semi-circular cross-section at various angular positions. The downstream end of the shaft 18 is provided with an abutment flange 34 against which the spring 22 abuts.

The sensor body 24 is shown in transverse cross- 25 section in Figure 2. The sensor body comprises an annular outer body 36. Within the body 36, there are provided, in the embodiment shown, three electrical coils 38,40,42. Each coil has a ferromagnetic core 37 which projects radially inwardly and is sized to leave 30 a small gap between an end portion of the core 37 and the cylindrical envelope 39 of the shaft 18. Two of the coils are secondary coils 38,40 and one coil is a primary coil 42.

The sensor body 24 is shown in longitudinal cross- 35 section in Figure 4. As shown, the upstream end 44 of the sensor body 24 has a smoothly curved contour so as

to minimize turbulence. The curved end 44 also acts as a protecting barrier for the coils 38, 40, 42.

In use, fluid flows within the conduit 2 between the inlet 4 and the outlet 6. The resulting pressure difference across the orifice 10 causes the plug 12 to move along the duct against the action of the spring 22. The position of the plug 12 thus depends upon the rate of flow within the conduit 2. The shaft 18 is connected to the plug 12 and likewise its position depends upon the flow rate in the conduit 2.

A primary voltage is applied to the primary coil 42, shown in Figure 2, and the difference between the induced voltages in the secondary coils 38,40 is measured. The induced voltage in any one of the secondary coils 38,40 is a function of the effective air gap between that coil and the primary coil 42. With the shaft 18 in the position shown in Figure 5, the induced voltages in the two secondary coils 38,40 are equal and so the difference is zero. However, with the shaft 18 in a different position, the induced voltages will differ as a result of the air gaps being unequal. Thus, in Figure 2 the induced voltage in secondary coil 40 is much greater than that induced in the secondary coil 38.

The angular orientation of the semi-circular cross section of the shaft 18, in the proximity of the sensor arrangement 24, is a function of the longitudinal position of the plug 12 within the conduit 2. As the flow rate within the conduit 2 increases, the orientation of the shaft cross-section rotates clockwise from the position shown in Figure 5. The induced voltage difference between the two secondary coils 38,40 therefore gives an indication of the position of the plug 12, which itself is a function of the flow rate within the conduit 2.

By appropriate calibration, the induced voltage

difference can be employed to provide a direct read-out of the flow rate in the conduit.

Alternative means for measuring the linear displacement of the contoured plug 12 may be provided, 5 for example involving the use of one or more proximity sensors in conjunction, for example, with a tapered shaft 18 instead of that shown in Figure 3.

Furthermore, although the displacement transducer 13 has been described in the context of fluid flow 10 measurement in a conduit, it will be appreciated that the displacement transducer 13 is novel and inventive in itself and has applications in the general field of measurement of linear displacement.

CLAIMS

1. A fluid flow meter comprising a flow body which is movable in a conduit for displacement by fluid flowing in the conduit whereby the position of the flow
5 body is dependent upon the fluid flow rate, a displacement transducer being provided which is responsive to displacement of the flow body and which comprises a ferromagnetic shaft and a ferromagnetic sensor body which are linearly displaceable relatively
10 to each other along an axis, the sensor body having a primary coil and a plurality of secondary coils, the coils being spaced apart from one another about the axis, the primary coil being coupled to each secondary coil, through a separate magnetic path, each path
15 including the shaft and the sensor body, the shaft being so configured that relative displacement between the shaft and the sensor body varies the magnetic coupling between the primary coil and the respective secondary coils thereby to provide an output signal
20 that is dependent upon the relative positions of the shaft and the sensor body.

2. A fluid flow meter as claimed in claim 1, in which the sensor body comprises an annular member having ferromagnetic cores which project radially
25 inwardly and about which the coils are mounted.

3. A fluid flow meter as claimed in claim 1 or 2, in which there are two secondary coils.

4. A fluid flow meter as claimed in claim 3, in which the primary coil and the secondary coils are
30 equally angularly spaced from one another about the shaft.

5. A fluid flow meter as claimed in any preceding claim, in which the shaft has a helical configuration.

35 6. A fluid flow meter as claimed in claim 5 in which the shaft has a semi-circular cross-section.

7. A fluid flow meter as claimed in any preceding claim, in which the flow body comprises a cone shaped plug which is disposed within an orifice of an orifice plate.

5 8. A fluid flow meter substantially as described herein with reference to, and as shown, in the accompanying drawings.

9. A linear transducer substantially as described herein with reference to, and as shown in,
10 the accompanying drawings.

Patents Act 1977
Examiner's report to the Comptroller under
Section 17 (The Search Report)

- 3 -

Application number

GB 9310233.3

Relevant Technical fields

- (i) UK CI (Edition L) G1N (NACDX, NAEB)
- (ii) Int CI (Edition 5) G01D 5/22; G01F 1/24, 1/26

Search Examiner

M G CLARKE

Databases (see over)

- (i) UK Patent Office
- (ii)

Date of Search

8 JULY 1993

Documents considered relevant following a search in respect of claims 1 TO 9

Category (see over)	Identity of document and relevant passages	Relevant to claim(s)
A	GB 2068560 A (TRANSAMERICA DE LAVAL) See especially Figures 1 and 6	
A	US 4297899 (ASS TO ZEMCO INC) See especially Figure 1	
A	US 4210891 (HOMER A BOUSHEY) Whole document	



--	--	--

Categories of documents

X: Document indicating lack of novelty or of inventive step.

Y: Document indicating lack of inventive step if combined with one or more other documents of the same category.

A: Document indicating technological background and/or state of the art.

P: Document published on or after the declared priority date but before the filing date of the present application.

E: Patent document published on or after, but with priority date earlier than, the filing date of the present application.

&: Member of the same patent family, corresponding document.

Databases: The UK Patent Office database comprises classified collections of GB, EP, WO and US patent specifications as outlined periodically in the Official Journal (Patents). The on-line databases considered for search are also listed periodically in the Official Journal (Patents).