



US 20250057228A1

(19) **United States**

(12) **Patent Application Publication**  
**Schumacher et al.**

(10) **Pub. No.: US 2025/0057228 A1**

(43) **Pub. Date: Feb. 20, 2025**

(54) **HEATING APPARATUS FOR AN AEROSOL GENERATING DEVICE**

**Publication Classification**

(71) Applicant: **JT International SA**, Geneva (CH)

(51) **Int. Cl.**  
*A24F 40/46* (2006.01)  
*A24F 40/20* (2006.01)

(72) Inventors: **Kevin Schumacher**, Jona (CH);  
**Sandro Feuerstein**, Embrach (CH);  
**Eduardo Jose Garcia Garcia**,  
Grand-Saconnex (CH)

(52) **U.S. Cl.**  
CPC ..... *A24F 40/46* (2020.01); *A24F 40/20*  
(2020.01)

(73) Assignee: **JT International SA**, Geneva (CH)

(57) **ABSTRACT**

(21) Appl. No.: **18/721,006**

A heating apparatus for an aerosol generating device includes an insulator with an internal wall and an external wall that are separated from one another; a cavity in which an aerosol forming substance can be received, positioned adjacent the internal wall of the insulator; and a heater provided inside the insulator in thermal contact with the internal wall of the insulator, configured to heat an aerosol forming substance received in the cavity by thermal conduction to generate an aerosol. The internal wall includes a substantially flat section, the substantially flat section including an inner face configured to compress a consumable including the aerosol forming substance when the consumable is received in the cavity, and an outer face on which the heater is provided.

(22) PCT Filed: **Jan. 30, 2023**

(86) PCT No.: **PCT/EP2023/052194**

§ 371 (c)(1),

(2) Date: **Jun. 17, 2024**

(30) **Foreign Application Priority Data**

Jan. 31, 2022 (EP) ..... 22154352.3

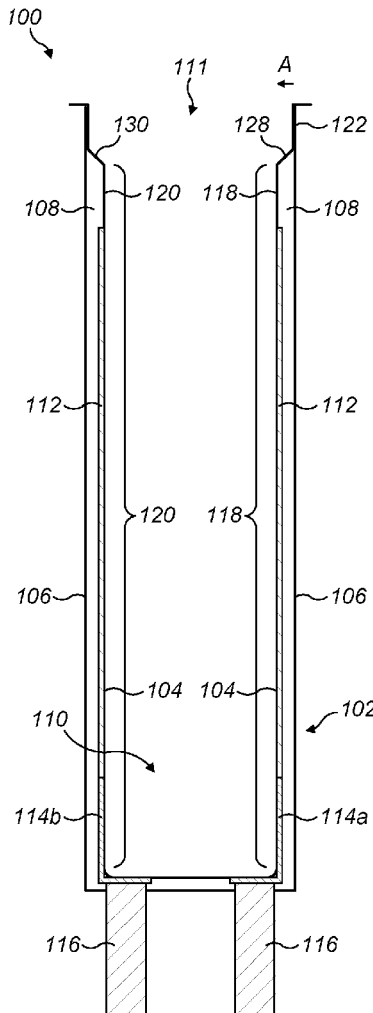

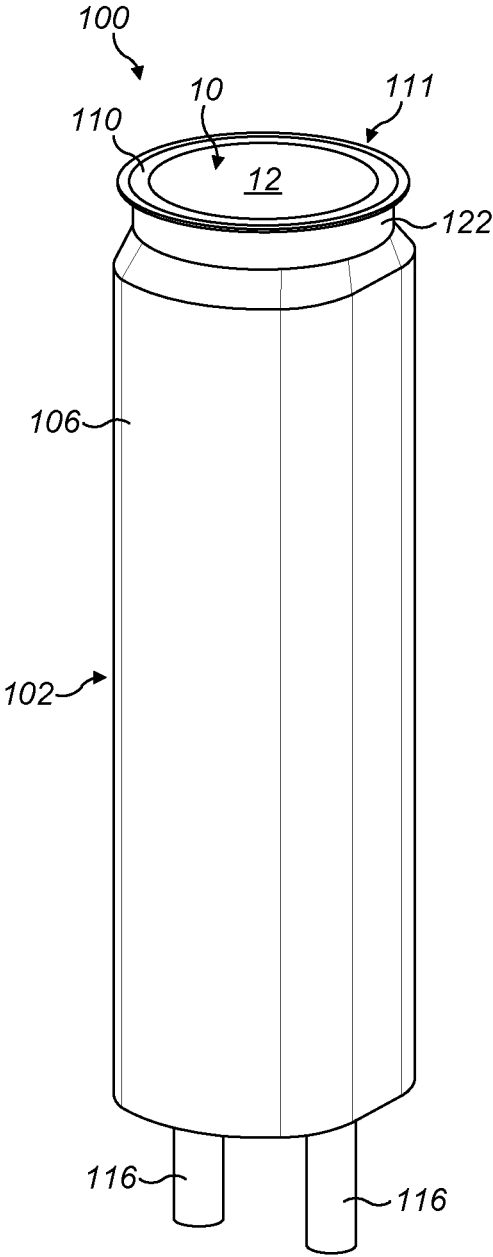

FIG. 1A

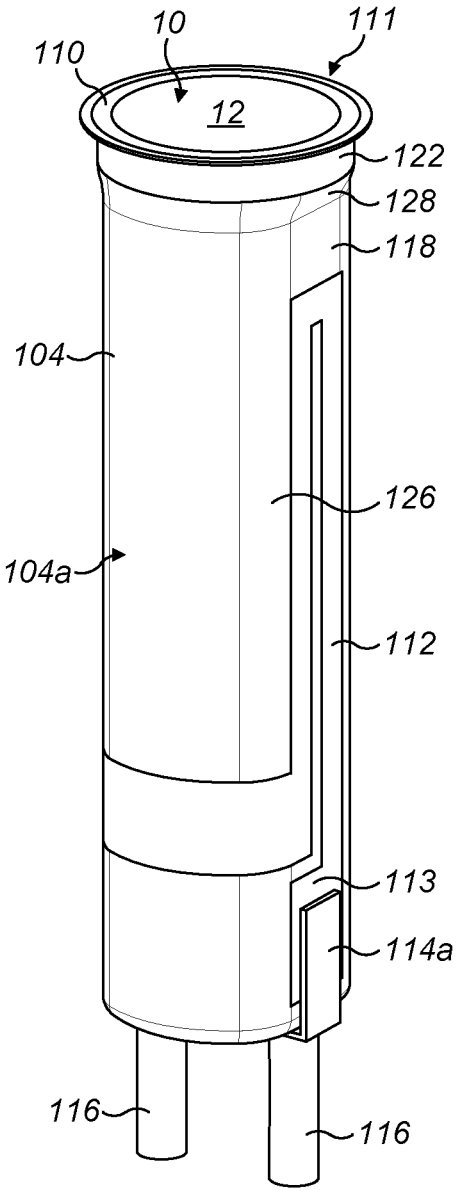

FIG. 1B

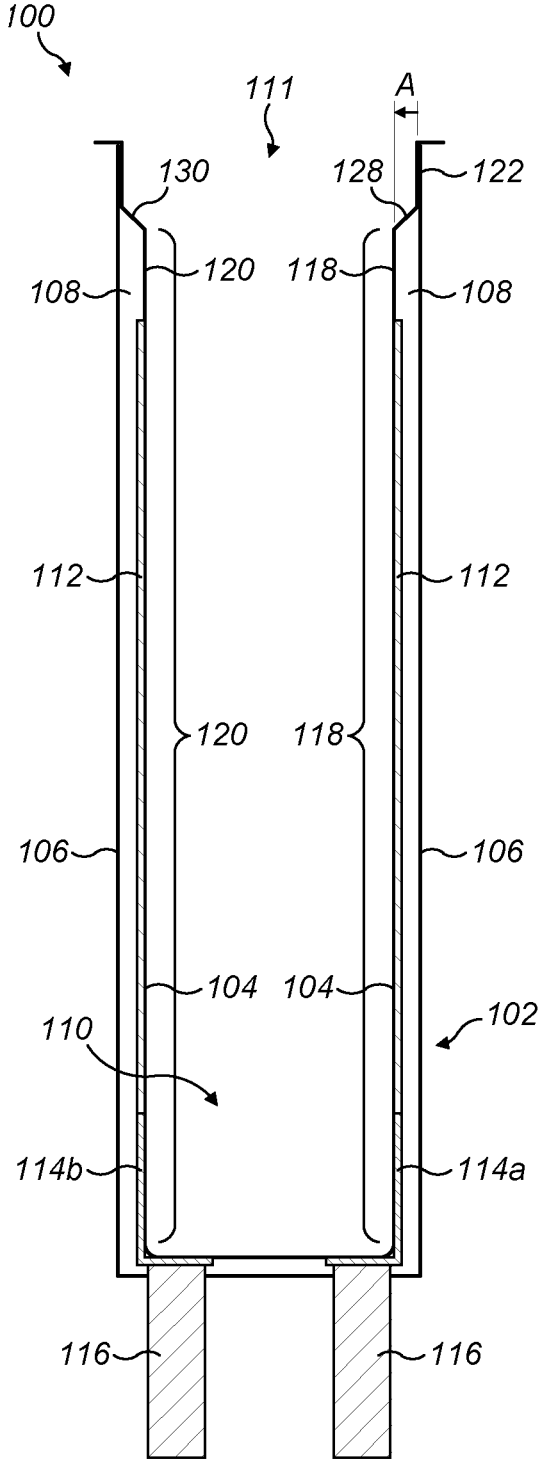

FIG. 2

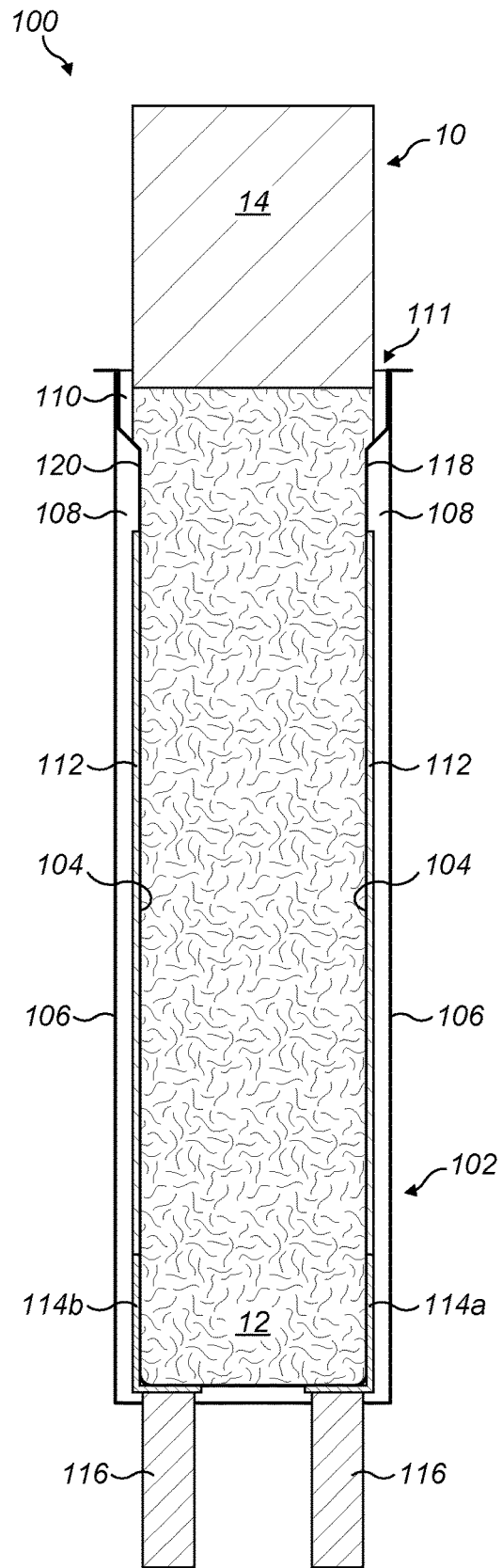

FIG. 3

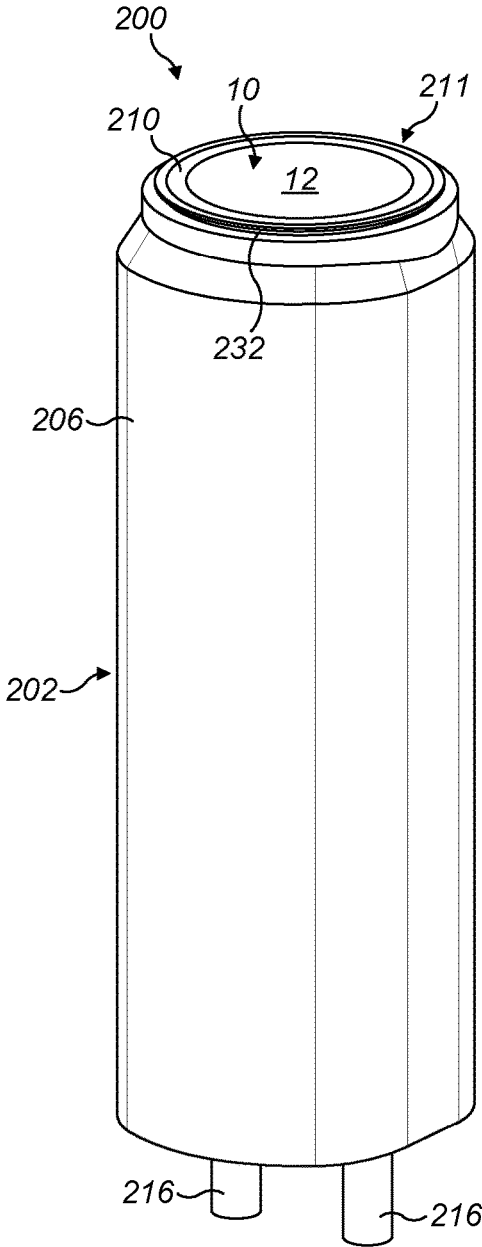

FIG. 4A

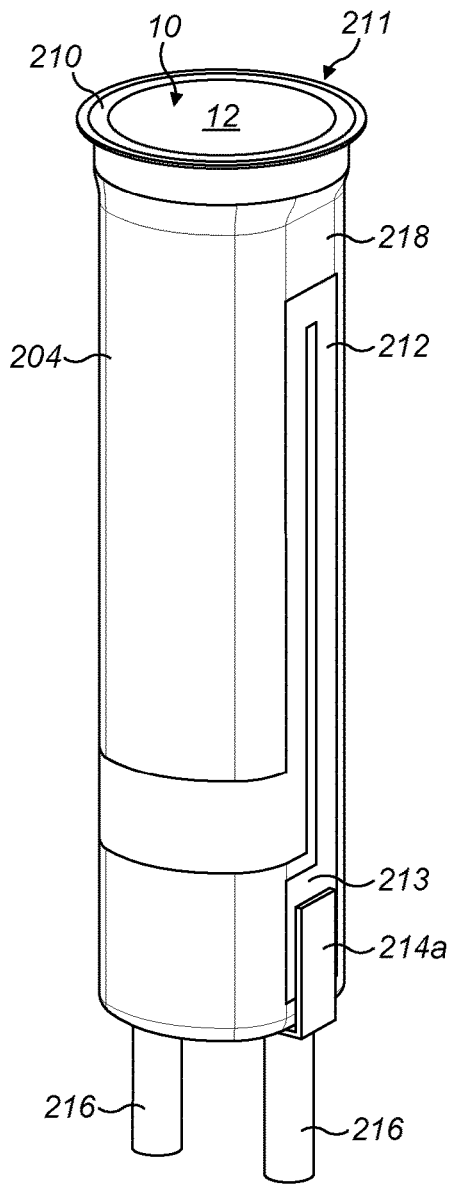

FIG. 4B

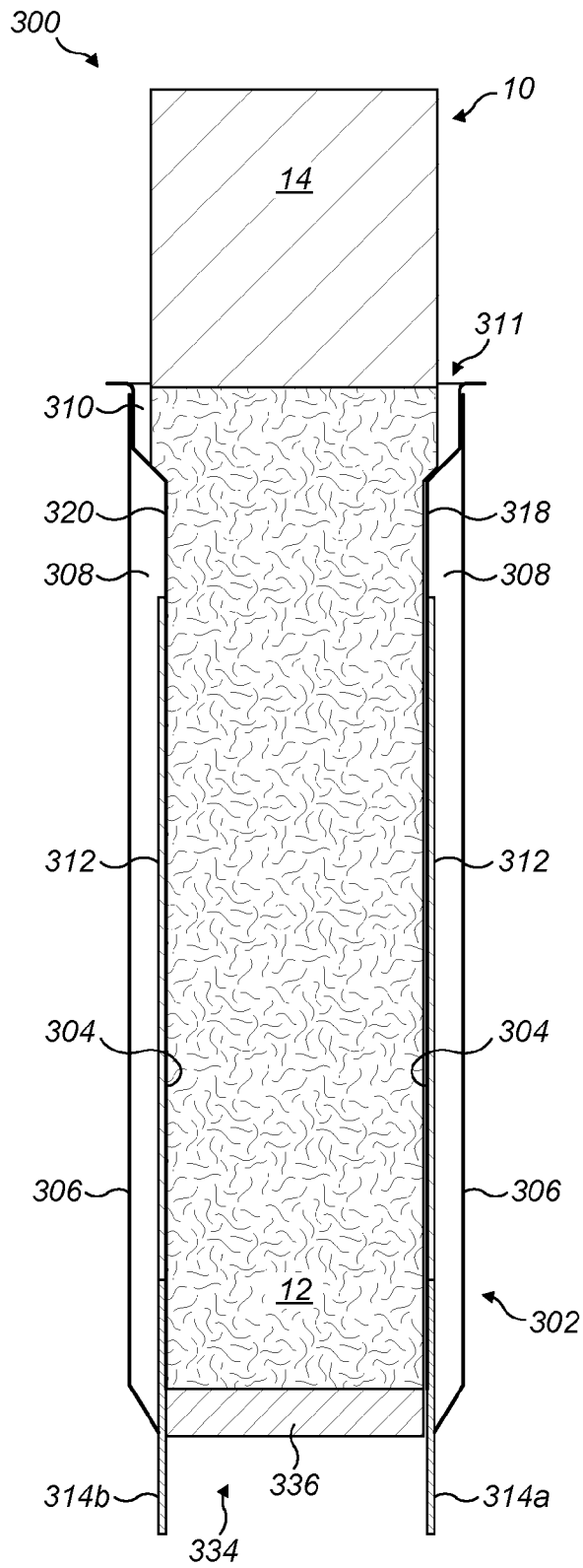

FIG. 5

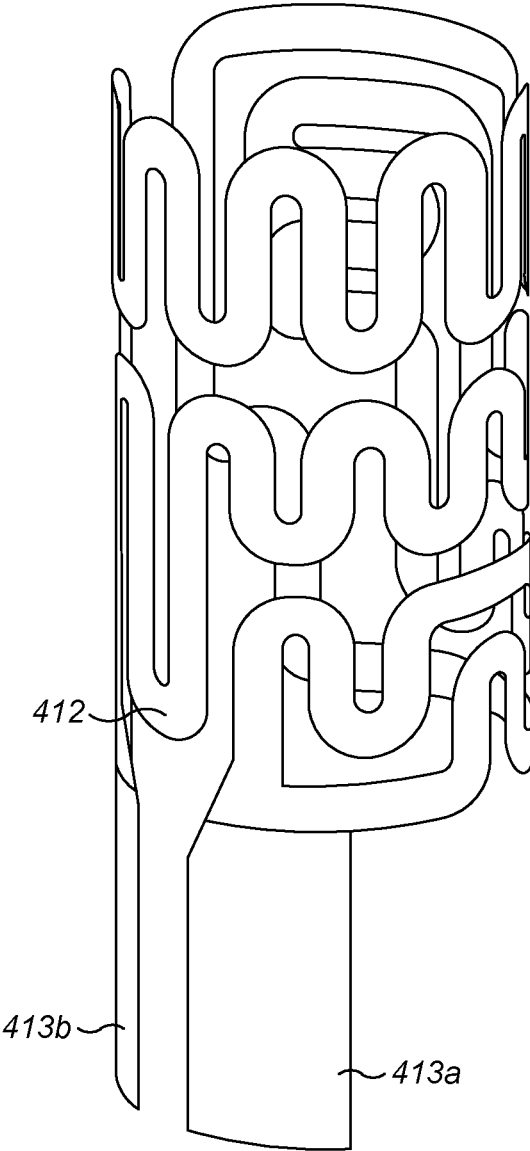

FIG. 6

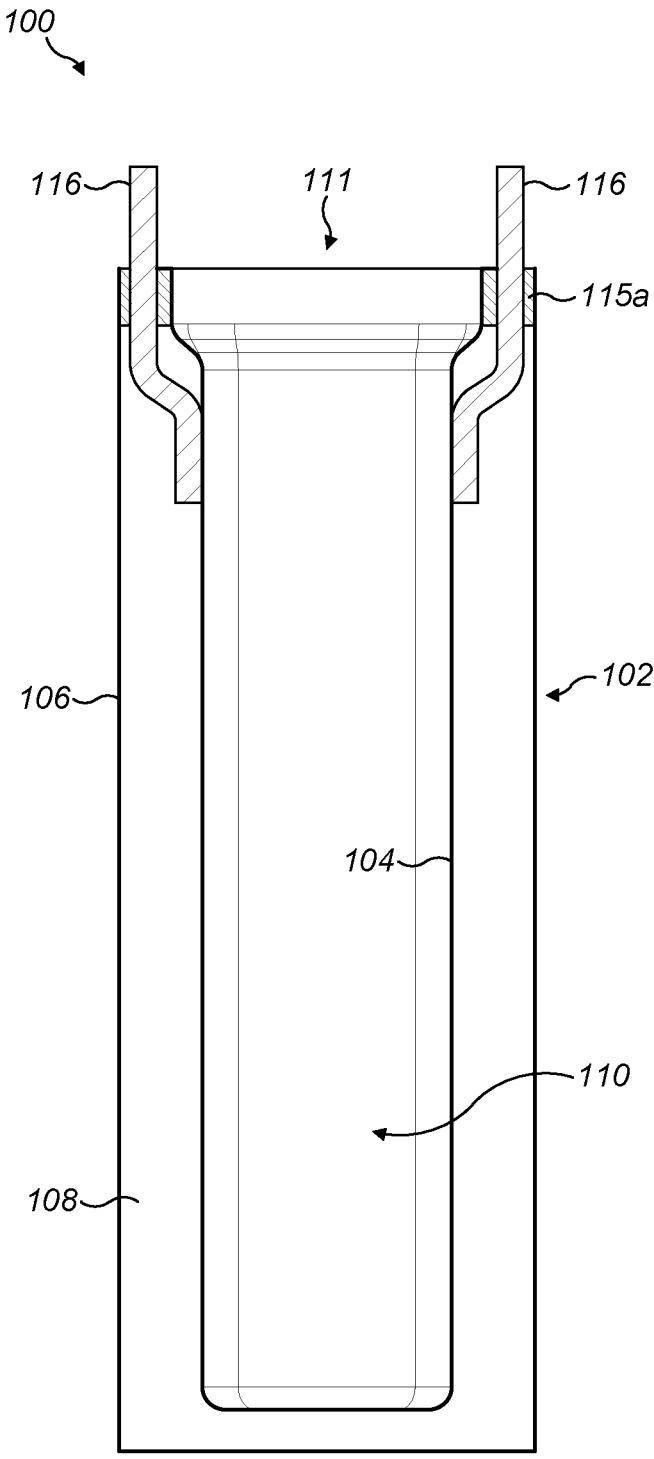

FIG. 7

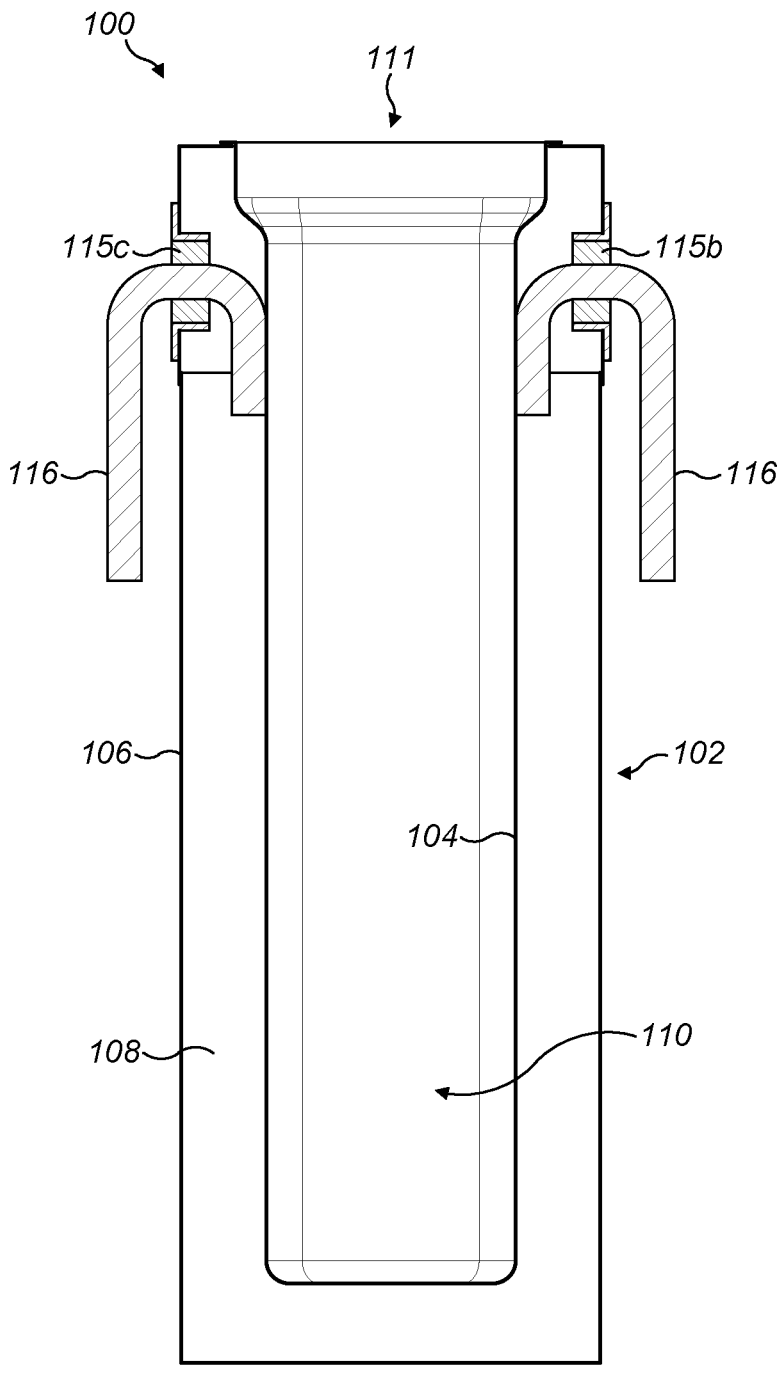

FIG. 8

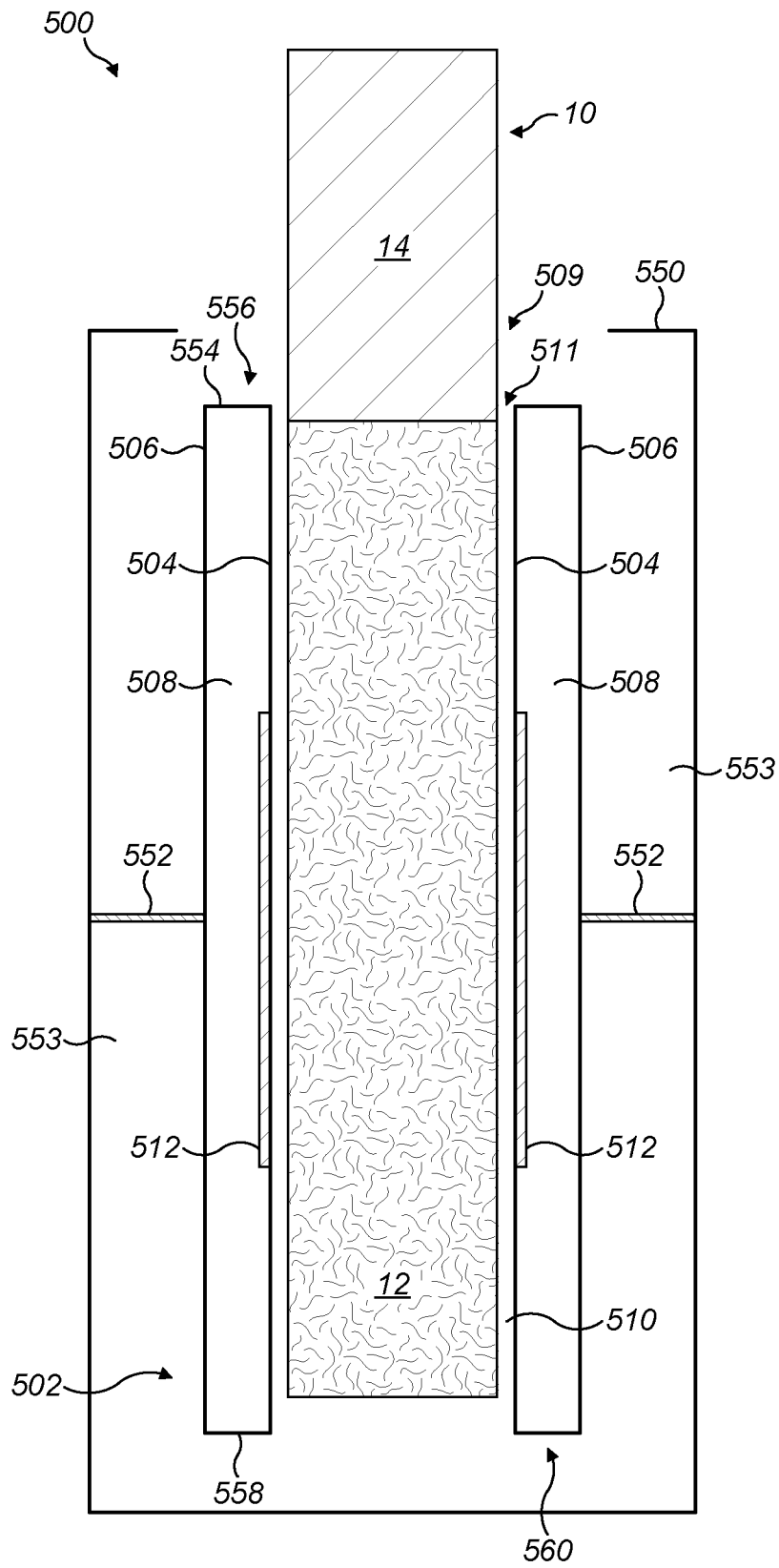

FIG. 9

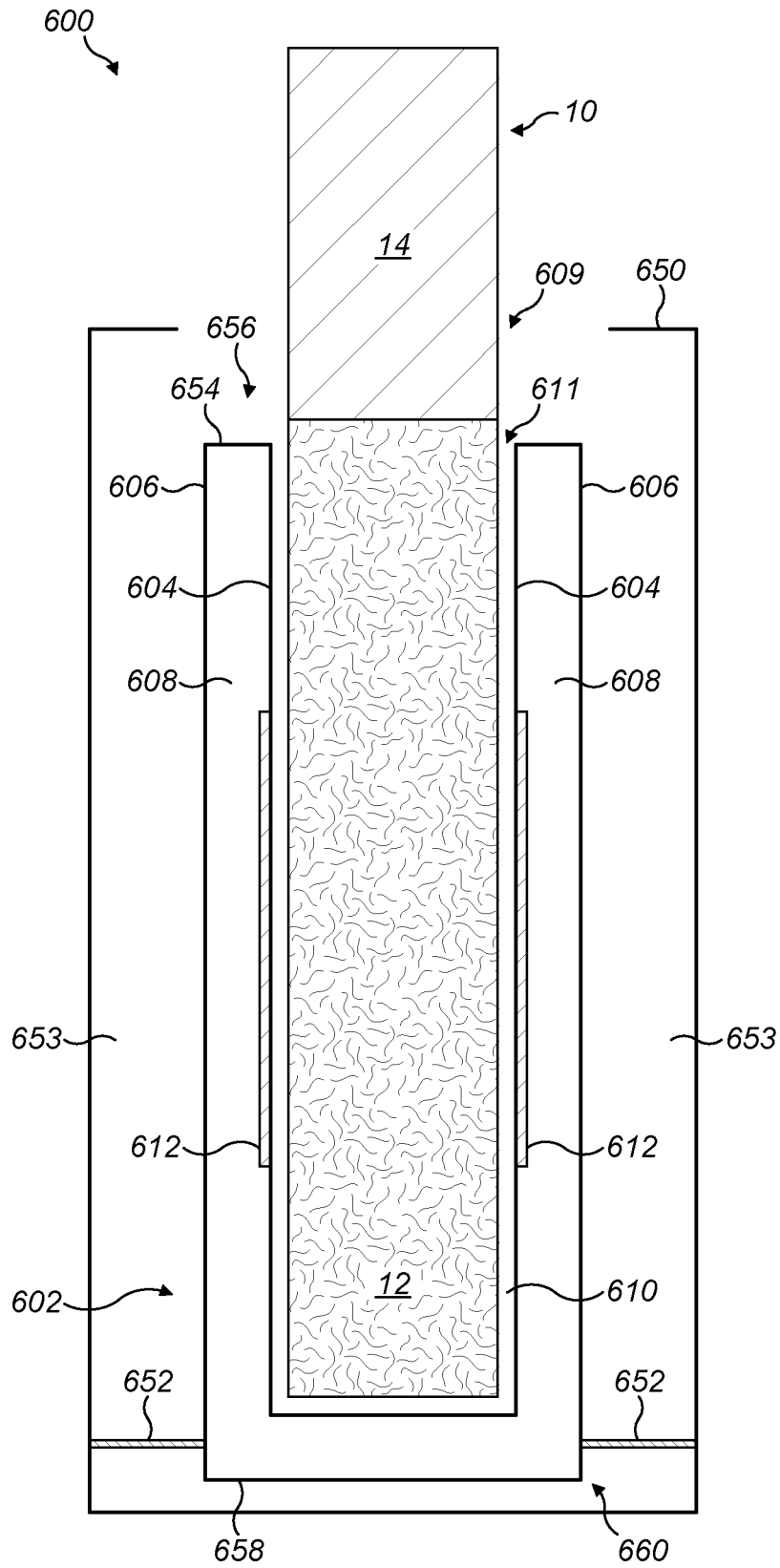

FIG. 10

## HEATING APPARATUS FOR AN AEROSOL GENERATING DEVICE

### FIELD OF INVENTION

**[0001]** The invention relates to a heating apparatus for an aerosol generating device. Specifically, the invention relates to a heating apparatus with a vacuum insulator.

### BACKGROUND TO THE INVENTION

**[0002]** Aerosol generating devices are typically carried around by a user on their person on a day-to-day basis. There is therefore a demand for lighter and more compact aerosol generating devices. Additionally, it is desirable that aerosol generating devices can be made as efficient as possible, so that the battery life can be extended and thus the convenience for the user can be increased. It is an object of the present invention to address these demands.

### SUMMARY OF INVENTION

**[0003]** According to an aspect of the invention, there is provided a heating apparatus for an aerosol generating device, comprising: an insulator, comprising an internal wall and an external wall that are separated from one another; a cavity in which an aerosol forming substance can be received, positioned adjacent the internal wall of the insulator; and a heater provided inside the insulator in thermal contact with the internal wall of the insulator, configured to heat an aerosol forming substance received in the cavity by thermal conduction to generate an aerosol; wherein the internal wall comprises a substantially flat section, the substantially flat section comprising an inner face configured to compress a consumable comprising the aerosol forming substance when the consumable is received in the cavity, and an outer face on which the heater is provided.

**[0004]** In this way, the device is made more compact because the heater is provided within the insulator rather than within the cavity. The heater is in thermal contact with the internal wall of the insulator and can heat the consumable via the internal wall. The insulator can contain a vacuum or a suitable insulating medium, such as air or any suitable powdered or fibrous insulators. The insulator drastically inhibits heat from escaping from the cavity by conduction via the external wall.

**[0005]** Preferably, the internal wall and the external wall are separated by a vacuum such that the insulator is a vacuum insulator. In this way, the internal wall and the external wall can enclose a vacuum to provide a more effective insulator for the heater. The internal wall of the vacuum insulator can thus serve a dual purpose of transferring heat to a consumable received in the adjacent cavity while also maintaining an insulating vacuum to insulate the cavity. This creates an efficient and compact heating apparatus for an aerosol generating device.

**[0006]** Advantageously, the substantially flat section enables the compression of a consumable received within the cavity. This creates a greater amount of contacting surface area between the internal wall and the consumable received in the cavity. Since conductive heat transfer between two bodies is proportional to the surface area in contact between them, the substantially flat section enables a more quick and efficient transfer of heat to the consumable. The compression of the consumable may also cause the aerosol forming substance in the centre of the consumable to

be heated more quickly than if no substantially flat section was present. Heating the aerosol forming substance more homogeneously in this way can help to avoid unwanted burning of the substance, leading to a better quality aerosol. Additionally, providing the internal wall of the insulator with a substantially flat section in this way avoids the need for a further component to compress or hold the consumable firmly in place, thereby providing a more compact heating apparatus with less component parts. Having less component parts can also be advantageous for reducing the thermal mass of the heating apparatus, which in turn reduces the amount of time needed for the cavity to reach the temperatures required for aerosol generation.

**[0007]** The heater is provided on the substantially flat section to deliver heat directly to the internal wall. This improves the efficiency of the device by ensuring that the maximum amount of heat possible is delivered to the internal wall rather than the external wall of the insulator, which could radiate or conductively transfer heat out of the insulator. Further, providing the heater directly on the internal wall avoids the need for intervening components to thermally couple the heater to the internal wall. The heater may be printed, coated or otherwise joined onto the internal wall. This may occur before or after the internal wall is bent or crimped into shape for use as part of the insulator. The substantially flat section may be completely or substantially flat. Providing the heater on the substantially flat section also enables good contact between the heater and the internal wall, thereby enabling effective heat transfer between the heater and the internal wall. Such a configuration may also be simpler to manufacture.

**[0008]** Preferably, the heater is a resistance heater. In this way, a compact, simple and easy to power form of heater is provided. Alternatively, the heater could be an induction heater powered by a coil surrounding the insulator.

**[0009]** Preferably, the substantially flat section extends along a longitudinal axis of the insulator. More preferably, the heater extends longitudinally on the outer face of the substantially flat section. In this way, the contact between the internal wall and the consumable can be increased along a full or substantially full portion of the consumable received in the cavity and the consumable can be heated efficiently along its full length.

**[0010]** Preferably, the internal wall is substantially cylindrical. Additionally, in some embodiments, the heater may be provided on the internal wall around a substantially full circumference of the internal wall in addition to being provided on the substantially flat section. A substantially cylindrical internal wall is useful as it enables the insulator to completely surround the consumable, thereby providing a more effective means of insulation. Providing the heater on the internal wall around the full circumference can enable a more homogenous heating of the aerosol forming substance, which may generate a better quality aerosol for the user to enjoy. This may also enable faster heating of the aerosol forming substance to aerosol generating temperatures.

**[0011]** Preferably, the internal wall comprises a plurality of substantially flat sections, the plurality of substantially flat sections each comprising a respective inner face configured to compress the consumable when the consumable is received in the cavity, and a respective outer face on which the heater is provided. In this way, the aerosol forming substance can be heated more homogeneously, which may generate a better quality aerosol for the user to enjoy.

Additionally, the consumable may be secured more effectively in the cavity. The heating apparatus may comprise two, three, or more than three substantially flat sections, which may be spaced evenly around the internal wall.

**[0012]** Preferably, the heater is provided on each of the plurality of substantially flat sections. In this way, the aerosol forming substance can be heated more evenly.

**[0013]** In some embodiments, the heater may be provided predominantly or only on the substantially flat sections, or on the single substantially flat section if there is only one substantially flat section. This may maximise the effectiveness of the heater relative to its size, enabling a smaller heater to be provided without comprising the ability of the heater to heat the consumable. Alternatively, if the size of the heater is not reduced, this may increase the speed or efficiency at which the heater heats the consumable. In other embodiments, separate heaters could be provided for each of the plurality of substantially flat sections.

**[0014]** Preferably, the heater comprises an exposed external surface having a material susceptible to an oxidation reaction in the presence of oxygen. Many heaters comprise materials that oxidise in the presence of oxygen, which can adversely affect the performance of the heater unless an anti-oxidation coating is provided. Allowing the heater to have an exposed external surface without an anti-oxidation coating in this way takes advantage of the heater being provided within a vacuum to make the heater less costly, have a lower mass, and/or easier to produce.

**[0015]** In some embodiments, the insulator comprises a first opening for receiving the aerosol forming substance and a second opening for enabling airflow through the cavity. In such embodiments, the insulator may be substantially tube-shaped. In other embodiments, the heater may comprise a single opening for airflow and for insertion of the consumable, in which case the insulator may be substantially cup-shaped.

**[0016]** Preferably, the external wall comprises a metal such as stainless steel and/or a plastic such as polyether ether ketone, PEEK. It has been found that the external wall may comprise PEEK while offering sufficient insulation properties. Using PEEK as part of the external wall may preferably reduce the weight of the heating apparatus. If the external wall comprises PEEK, the PEEK may be a poorly thermally conducting form of PEEK.

**[0017]** Preferably, the heating apparatus further comprises an electrical insulation layer provided between the heater and the internal wall. In this way, the safety of the device may be increased, as electrical conduction to other components of the heating apparatus or the aerosol generating device may be avoided. The electrical insulation layer could be provided as a layer of material deposited on the internal wall. Alternatively, the layer could be provided as a partial or full coating on the heater.

**[0018]** Preferably, the side of the internal wall facing the cavity is exposed to the cavity such that the consumable can be received in the cavity without the consumable coming into contact with other components. This allows the heater to heat the consumable more efficiently and provides a more compact heating apparatus.

**[0019]** In some embodiments, the insulator comprises a flared opening configured to enable the consumable to be received in the cavity. In such cases, the substantially flat section may be provided distally or longitudinally offset from the opening to the cavity. The substantially flat section

may restrict the diameter of the cavity with respect to the diameter of the opening to the cavity. In this way, the consumable can be easier to insert into the flared opening of the cavity before it is pinched by the substantially flat section.

**[0020]** The substantially flat section or sections of the internal wall may be joined to surrounding sections of the internal wall by a plurality of smooth sloped surfaces. This may reduce the chances of the consumable being torn or damaged when inserted to the cavity. This may also increase the surface area in contact between the internal wall and the consumable by reducing the amount of air trapped between the consumable and the internal wall.

**[0021]** Preferably, the internal wall has a thickness of about 0.1 mm or less. In this way, the internal wall has a thickness corresponding to a threshold of significantly improved thermal efficiency of the insulator. The entire internal wall can have a thickness of about 0.1 mm or less, or only a portion of the internal wall can have this thickness. For example, the first substantially flat section and the second substantially flat section may have a thickness of 0.1 mm, and the remaining portions may be thicker. Providing the internal wall with a substantially uniform thickness of about 0.1 mm or less may be simpler to manufacture compared to an internal wall with more than one thickness, and may also be more thermally efficient, especially when the insulator is a vacuum insulator.

**[0022]** Preferably, the heating apparatus comprises one or more wires configured to connect the heater to a power source. The one or more wires may be positioned through one or more gaps provided on a longitudinal face of the external wall. In this way, the wires can have a lower mass, which can be advantageous in terms of carrying weight for the user as well as for reducing the thermal mass of the device. Additionally, the wires can have contact mainly with the external wall, which causes the wires to carry less heat out of the insulator due to the external wall's lower operating temperature. One or more seals may be provided in the gaps to prevent air from entering the insulator and to secure the wires in place. The gaps may be provided towards either end of the insulator, or elsewhere on the external wall.

**[0023]** Alternatively, the one or more wires may be positioned through one or more gaps in the insulator provided at a longitudinal end of the insulator and adjacent to an opening to the cavity. In this way, the wires can have less contact with the insulator. This causes the wires to carry less heat out of the insulator by conducting less heat from the walls of the insulator. This configuration can also be particularly simple to manufacture, thereby potentially reducing production costs. In one example embodiment, the wires have a single point of contact with the insulator. The internal wall and the external wall may be connected by one or more seals provided around the wires and configured to prevent air from entering the insulator and to hold the wires in place. In this example, the insulator may enclose a gaseous insulating medium or a vacuum.

**[0024]** According to another aspect of the invention, there is provided an aerosol generating device configured to generate an aerosol for inhalation by a user, comprising the heating apparatus described above.

**[0025]** Preferably, the aerosol generating device further comprises a housing configured to house components of the aerosol generating device, and one or more support structures attached to the insulator to couple the insulator to the

housing; wherein the one or more support structures are positioned on the insulator to maximise the length of a conduction path from the heater to the one or more support structures. In this way, the amount of heat conducted to the housing in use can be minimised. This minimises the temperature of the housing during operation of the device and may also increase the efficiency of the aerosol generating device.

**[0026]** According to another aspect of the invention, there is provided an aerosol generating device configured to generate an aerosol for inhalation by a user, comprising: a heater configured to heat an aerosol forming substance received within the aerosol generating device; a housing configured to house components of the aerosol generating device; an insulator, configured to insulate the housing from heat produced by the heater; and one or more support structures attached to the insulator to couple the insulator to the housing; wherein the one or more support structures are positioned on the insulator to maximise the length of a conduction path from the heater to the one or more support structures.

**[0027]** It is desirable to minimise the temperature of the housing of the aerosol generating device in use for safety and efficiency. This is particularly the case for heat-not-burn aerosol generating devices, which typically utilize heating ovens operating at very high temperatures. Maximising the conduction path length in this way is advantageous because heat from the heater may, for example, have further to travel by conduction along the walls of the insulator before reaching the support structures. While the heat is travelling by conduction, some heat is continuously lost from the insulator due to convection and radiation processes. Thus, less heat from the heater reaches the support structures, which are positioned to maximise the length of a conduction path from the heater to the one or more support structures. This in turn means that less heat is conducted to the housing during use. In this way, the temperature of the housing during operation is minimised and the efficiency of the aerosol generating device is improved.

**[0028]** It is also possible to maximise the effective conduction path length by altering the heat conduction properties of the materials physically connecting the heater and the one or more support structures. For example, it may be possible to provide a thermally insulating component configured so that heat must travel through the thermally insulating component to reach the one or more support structures from the heater by conduction. The thermally insulating component could be a poorer thermal conductor compared to other materials of the vacuum insulator. Alternatively, the thermally insulating component could have geometric properties, such as a reduced thickness, that inhibits the rate of conductive heat flow through the insulating component. The position of the one or more support structures may generally correspond to the coldest region of the vacuum insulator in use. Alternatively, the one or more support structures may be positioned to maximise the conduction path length from the heater to the one or more support structures while balancing other competing demands, such as structural integrity.

**[0029]** The insulator can contain a vacuum or, alternatively, a suitable insulating medium, such as air or any suitable powdered or fibrous insulators. In the case where the insulator contains a non-gaseous insulating medium, heat may be able to travel by conduction along a direct path

through the insulator to the support structures. Therefore, maximising the conduction path from the heater to the connection structures may require a different positioning of the connection structures on the insulator. In such example, the support structures can be attached to the insulator at a point on the external surface of the insulator that is furthest from the heater. In the case where the insulator encloses a vacuum or gaseous insulating medium, the conduction path length can be maximised despite the heater being located physically close to the support structures, e.g., if the support structures are located at the closed end of a cup-shaped insulator.

**[0030]** Proportionally, a vacuum insulator may derive more thermal efficiency savings in comparison to non-vacuum insulators from this more optimal positioning of the support structures. This can be due to heat being forced to travel by conduction along the walls of the vacuum insulator, rather than through an insulating medium. For example, heat can be forced to take a more sinuous or serpentine conduction path to reach the connection structures when they are attached to a vacuum insulator. Thus, the minimum possible conduction path length can be increased to a greater extent.

**[0031]** Preferably, the insulator is coupled to the housing only by the one or more support structures. In this way, heat is prevented from reaching the housing by other intervening components.

**[0032]** Preferably, the insulator comprises an internal wall and an external wall between which a vacuum or an insulating medium is enclosed.

**[0033]** In some embodiments, the internal wall and the external wall are joined only at a first end of the insulator, and the one or more support structures are attached to the insulator at a second end of the insulator that is distal to the first end. In this way, the one or more support structures are positioned to maximise the conduction path length from the heater to the support structures. This positioning takes into account a specific geometry of the insulator in which the internal wall and the external wall are joined only at a single end. In particular the insulator may be a vacuum insulator, which may receive the greatest efficiency saving in this arrangement compared to other embodiments in which the insulator does not contain a vacuum.

**[0034]** In some embodiments, the internal wall and the external wall are joined at a first end of the insulator and a second end of the insulator distal to the first end, and the one or more support structures are attached to the insulator at a position on the external wall that is approximately equidistant from the first end and the second end. In this way, the one or more support structures are positioned to maximise the conduction path length from the heater to the support structures. This positioning takes into account a specific geometry of the insulator wherein the internal wall and the external wall are joined at two opposing ends. In particular the insulator may be a vacuum insulator, which may receive the greatest efficiency saving in this arrangement compared to other embodiments in which the insulator does not contain a vacuum.

**[0035]** Preferably, the aerosol generating device comprises a cavity in which the aerosol forming substance can be received, positioned adjacent the internal wall of the insulator.

**[0036]** Preferably, the heater is provided on the internal wall of the insulator. More preferably, the heater is provided within a vacuum enclosed by the insulator. The insulator

may comprise first and second substantially flat portions, as described above with respect to a previous aspect of the invention. In this way, the aerosol generating device can derive the benefits of the heating apparatus described above.

[0037] Preferably, the aerosol generating device comprises an air gap positioned between the insulator and the housing. In this way, conduction of heat to the housing is avoided.

[0038] Preferably, the one or more support structures comprise struts or rods. In this way, the insulator can be coupled to the housing using structures that may have a relatively small cross section, which can reduce the rate of heat transfer to the housing. In other embodiments, the one or more support structures may form an integral part of the housing. In one example, the struts or rods, or any other alternative support structures, could be provided at a plurality of spaced positions around a circumference of the external wall of the insulator.

#### BRIEF DESCRIPTION OF THE DRAWINGS

[0039] Embodiments of the invention are now described, by way of example, with reference to the drawings, in which:

[0040] FIG. 1A shows a perspective view of a heating apparatus according to an embodiment of the invention;

[0041] FIG. 1B shows a perspective view of the heating apparatus with the external wall of the vacuum insulator removed, according to an embodiment of the invention;

[0042] FIG. 2 shows a cross-sectional schematic diagram of the heating apparatus according to an embodiment of the invention;

[0043] FIG. 3 shows a cross-sectional schematic diagram of the heating apparatus according to an embodiment of the invention, with a consumable inserted into the cavity of the vacuum insulator;

[0044] FIG. 4A shows a perspective view of a heating apparatus according to an embodiment of the invention;

[0045] FIG. 4B shows a perspective view of the heating apparatus with the external wall of the vacuum insulator removed, according to an embodiment of the invention;

[0046] FIG. 5 shows a cross-sectional schematic diagram of the heating apparatus according to an embodiment of the invention, with a consumable inserted into the cavity of the vacuum insulator;

[0047] FIG. 6 shows a perspective view of a heater according to an embodiment of the invention;

[0048] FIG. 7 shows a cross-sectional schematic diagram of a heating apparatus according to an embodiment of the invention;

[0049] FIG. 8 shows a cross-sectional schematic diagram of a heating apparatus according to an embodiment of the invention;

[0050] FIG. 9 shows a cross-sectional schematic view of an aerosol generating device according to an embodiment of the invention; and

[0051] FIG. 10 shows a cross-sectional schematic view of an aerosol generating device according to an embodiment of the invention.

#### DETAILED DESCRIPTION OF THE DRAWINGS

[0052] FIGS. 1A and 1B show a perspective view of a heating apparatus for an aerosol generating device according to an embodiment of the invention. A heating apparatus 100

is provided and comprises a vacuum insulator 102 comprising an internal wall 104 and an external wall 106, spaced radially apart from one another so that a vacuum 108 is enclosed between them. FIG. 1A shows the heating apparatus 100 as it would appear during use, while FIG. 1B shows the heating apparatus 100 with the external wall 106 removed so that the interior of the vacuum insulator 102 and the internal wall 104 can be viewed.

[0053] FIG. 2 shows a cross-sectional schematic diagram of the heating apparatus 100 according to the embodiment of FIGS. 1A and 1B. The heating apparatus 100 comprises a cavity 110 that is provided adjacent the internal wall 104 and is configured to receive a consumable 10 comprising tobacco 12. FIG. 3 shows a cross-sectional schematic diagram of the heating apparatus 100 according to the embodiment of FIGS. 1A, 1B, and 2 with the consumable 10 inserted into the cavity 110.

[0054] The consumable 10 can be inserted into the cavity 110 by a user via an opening 111 to the cavity 110 to be held in place by friction with the internal wall 104. A heater 112 is provided within the vacuum 108 and on the internal wall 104. The heater 112 is configured to heat the internal wall 104 by conduction so that the internal wall 104 heats the consumable 10 and the air inside the cavity 110 by conduction and radiation. The heater 112 can be powered by a battery or any other power source provided on an aerosol generating device. The heater 112 comprises a first end 113 in electrical connection a first wire connector 114a and a second end (not shown) in electrical connection with a second wire connector 114b. Each of the first wire connector 114a and the second wire connector 114b are in electrical connection with one of two wires 116, which are configured to connect the heater 112 to a battery. The internal wall 104 further comprises a first flat section 118 and a second flat section 120, each of which extend longitudinally along a longitudinal axis of the vacuum insulator 102. The first and second flat sections 118, 120 are configured to compress the consumable 10 when it is received within the cavity 110 to improve the efficiency of heat transfer from the heater 112 to the tobacco 12. The internal wall 104 has an inner face (not shown), which faces the cavity 110 and is obscured by the tobacco 12 in FIGS. 1A and 1B, and an outer face 104a, visible in FIG. 1B. The heater 112 is provided on the outer face of the first flat section 118 and the outer face of the second flat section 120.

[0055] FIGS. 2 and 3 show the vacuum 108 that is enclosed between the internal wall 104 and the external wall 106. The consumable 10 may also comprise a filter 14, which is shown in FIG. 3 and omitted from FIGS. 1A and 1B for clarity. In use, the user can draw air from the cavity 110 through the filter 14 to carry aerosol generated in the cavity 110 to the user to enjoy.

[0056] The vacuum insulator 102 is hollow and encloses a vacuum 108 between its curved internal wall 104 and its curved external wall 106. The vacuum insulator 102 has a substantially cylindrical shape that enables the vacuum insulator 102 to fully surround the consumable 10 to maximise the effectiveness of the insulation. The vacuum insulator 102 is elongate along its longitudinal axis, which enables it to receive a consumable 10 in the form of an elongate rod comprising tobacco 12. The vacuum insulator 102 has an approximately elliptical or circular cross-section when viewed along one of its ends, parallel to its longitudinal axis; however in other embodiments the vacuum

insulator **102** may have other types of cross sectional shape, for example shapes that are approximately square or polygonal.

[0057] The vacuum insulator **102** comprises an opening **111** for receiving the consumable **10** at one longitudinal end and is closed at the opposite end. Thus, when viewed perpendicularly to its longitudinal axis as shown in FIG. 2, the vacuum insulator **102** has a cross-section that is cup-shaped. In other embodiments, the vacuum insulator **102** may be open at both longitudinal ends such that it has a tube-shaped cross-section when viewed perpendicularly to its longitudinal axis, as described further below with respect to FIG. 5.

[0058] In other embodiments, the vacuum insulator **102** may instead be a non-vacuum insulator, i.e., an insulator containing an insulating medium such as air, fibrous or powdered insulators.

[0059] The opening **111** is flared outwardly to enable a user to insert easily the consumable **10** into the cavity **110**. A top section **122** of the internal wall **104** has an increased diameter with respect to an internal region of the internal wall **104** that has a more restricted diameter in order to compress the consumable **10** when it is received in the cavity **110**. In other embodiments, the top section **122** or opening **111** may not be flared and the internal wall **104** may have a cross-section that is the same across the full longitudinal extent of the internal wall **104**.

[0060] In the embodiment of FIGS. 1 to 3, the internal wall **104** comprises stainless steel. However, in other embodiments the internal wall **104** may comprise other suitable materials that have properties suitable for transmitting heat from the heater **112** into the cavity **110**, such as other metals, metal alloys, or ceramics.

[0061] The internal wall **104** comprises a first flat section **118**, which may be substantially flat or completely flat. The first flat section **118** is positioned radially inwardly from the longitudinally adjacent top section **122** of the internal wall **104** that is positioned closer to the opening **111**, as shown by the arrow A in FIG. 2. The first flat section **118** is connected to a circumferentially adjacent section **126** as shown in FIG. 1B, which may have an elliptical or circular curvature. The first flat section **118** is also connected to the internal wall **104** by a first sloped section **128** that slopes towards the centre of the cavity **110**. The first flat section **118** extends along the internal wall **104** along a substantially full longitudinal extent of the internal wall **104**.

[0062] The second flat section **120** is provided on the internal wall **104** opposite the first flat section **118**. In other embodiments, the first and second flat sections **118**, **120** may have other relative positions on the internal wall **104**. The example embodiment of FIGS. 1 to 3 comprises two flat sections; however the internal wall **104** may comprise only a single flat section, or may comprise more than two flat sections.

[0063] The second flat section **120** is configured in the same way as first flat section **118** and is connected to the top section **122** of the internal wall **104** by a second sloped surface **130**, as shown in FIGS. 2 and 3. The first sloped surface **128** and the second sloped surface **130** are preferably smoothly sloped to guide the consumable **10** into the cavity **110** smoothly as it is inserted by a user. The use of smooth sloped surfaces rather than harder edges can reduce air

pockets in the cavity **110** and thus can increase the amount of surface area in contact between the internal wall **104** and the consumable **10**.

[0064] The external wall **106** comprises stainless steel. In other embodiments, the external wall **106** could comprise other suitable materials, as described further below. The external wall **106** comprises a single curved face that is substantially or wholly cylindrical. Other shapes of external wall **106** could be implemented in accordance with alternatively shaped vacuum insulators. The internal wall **104** and the external wall **106** are joined or sealed together in an airtight manner at both of two longitudinal ends of the vacuum insulator **102** to ensure that the vacuum **108** remains contained between the internal wall **104** and the external wall **106**. In other embodiments, the vacuum insulator **102** may comprise additional adjoining walls perpendicular to the longitudinal axis of the vacuum insulator **102** that connect the internal wall **104** and the external wall **106**.

[0065] The cavity **110** is substantially cylindrical and is positioned immediately adjacent the internal wall **104**. Preferably, the side of the internal wall **104** facing the cavity **110**, i.e., the “inner face” of the internal wall **104**, is substantially or completely free of additional components so that the consumable **10** can be in direct contact with the inner face when it is received in the cavity **110**. This can maximise the efficiency of heat transfer from the internal wall **104** to the consumable **10**. Further, the lack of additional components keeps the thermal mass of the heating apparatus low, which can improve the amount of time required to heat the tobacco **12** to aerosol generating temperatures.

[0066] In the embodiment of FIGS. 1 to 3, the heater **112** is a substantially flat resistance heater configured to generate heat when applied with an electric current. In other embodiments, the heater **112** may be an induction heater, powered by an induction coil provided around the vacuum insulator. A resistance heater may be preferable as it may provide a more compact heating solution.

[0067] The heater **112** comprises a winding resistive heating track that extends from a first end **113** of the heater **112** to a second end (not shown). The track follows a sinuous path along the length of the first flat section **118** and the second flat section **120**, as shown in FIG. 1B. The first end **113** and the second end of the heater **112** are each configured to make electric connection with the first and second wire connectors **114a**, **114b**, respectively, which in turn connect to the wires **116**. The wires **116** can be connected with a battery provided on an aerosol generating device.

[0068] The heater **112** may be printed or otherwise joined onto the outer face **104a** of the internal wall **104**. Thus, the heater **112** may provide “trace heating” to the cavity **110**. As shown in FIG. 1B, the heater **112** may have a sinuous shape on the surface of the internal wall **104** so that a substantially full portion of the first flat section **118** and/or the second flat section **120** is/are covered. As described further below with reference to FIG. 6, the heater **112** may have other shapes.

[0069] The heater **112** may comprise a material susceptible to an oxidation reaction in the presence of oxygen, and also may be provided without an anti-oxidation coating. Exposing the heater **112** to the vacuum **108** in this way takes advantage of the lack of oxygen in the vacuum insulator **102** to make the heater **112** cheaper and/or easier to manufacture.

[0070] The heater **112** is provided on the outer face **104a** of the internal wall **104** on the first and second flat sections **118**, **120**, as shown in FIG. 1B, in order to maximise the

efficiency of the heating. In some cases, this maximisation of the heating efficiency may be sufficiently high such that it is not necessary for the heater 112 to cover other sections of the internal wall 104 to achieve fast or effective heating. Thus, the heater 112 may be provided predominantly, mostly or only on the first and second flat sections 118, 120 to minimise the size of the heater 112, thereby reducing the overall weight and cost of the heating apparatus 100.

[0071] In other examples, the heater 112 may also be provided elsewhere on the internal wall 104, additionally to being provided on the first and second flat sections 118, 120. The heater 112 may substantially cover the outer face 104a of internal wall 104, and/or may be provided on the internal wall 104 around a substantially full circumference of the internal wall 104. In some examples, this may heat the consumable 10 faster or more homogeneously.

[0072] Electrical insulation may be provided between the heater 112 and the internal wall 104 to avoid unwanted electrical currents reaching other parts of the heating apparatus 100 or of an aerosol generating device comprising the heating apparatus 100. The electrical insulation may be any kind of electrical insulation suitable for enabling effective heat transfer from the heater 112 to the internal wall 104.

[0073] The wires 116 can each be connected to a terminal of the battery at one end and to one of the first and second wire connectors 114a, 114b at their respective opposite ends. The first and second wire connectors 114a, 114b may have a substantially flat shape to allow them to be provided inside the vacuum insulator 102 without touching the external wall 106. The wires 116 may be provided through one or more sealed apertures in the vacuum insulator 102 and connected to the first and second wire connectors 114a, 114b inside the vacuum insulator 102. Preferably, the wires 116 are provided through sealed apertures towards either longitudinal end of the vacuum insulator 102.

[0074] The heating apparatus 100 can be used with or provided in an aerosol generating device. The aerosol generating device would typically comprise a battery for powering the heater 112, a button or other input mechanism to enable a user to initiate the heater 112, and a controller to control the electronic components of the device, such as the heater 112. The heating apparatus 100 may be provided within a housing of the aerosol generating device, wherein the housing comprises an opening aligned with the opening 111 of the heating apparatus 100. The aerosol generating device may be configured as an electric smoking device.

[0075] The consumable 10 comprises tobacco 12 and a filter 14, which may be held together by a tipping wrapper. Preferably, the consumable 10 is a cylindrical rod; however other shapes of consumable 10 designed to be received within the cavity 110 could also be used. Other forms of aerosol forming substance may be used alternatively or addition to tobacco.

[0076] Now, an example use of the heating apparatus 100, as used within an aerosol generating device, will now be described with reference to FIGS. 1 to 3.

[0077] In use, a user can insert the consumable 10 through the opening 111 into the cavity 110. The consumable 10 may have a diameter slightly less than the opening 111 to allow the consumable 10 to be initially received in the cavity 110. The first flat section 118 and the second flat section 120 are provided at positions that are longitudinally offset from the opening 111, and restrict the diameter of the cavity 110 relative to the diameter of the opening 111 to the cavity 110.

Thus, the consumable 10 is squeezed by the first flat section 118 and the second flat section 120 as it is pushed further into the cavity 110 by the user, until it is fully received in the cavity 110 as shown in FIG. 3. This increases the amount of surface area in contact between the consumable 10 and the internal wall 104 and secures the consumable 10 securely within the cavity 110 by friction.

[0078] When the user is ready to initiate vaporisation, the user may press a button provided on the aerosol generating device, after which the controller may allow a current to flow from the battery to the heater 112. The electrical resistance of the heater 112 generates heat that is transmitted to the first and second flat sections 118, 120 of the internal wall 104 by conduction and radiation.

[0079] The first and second flat sections 118, 120 may increase the surface area of the internal wall 104, and thus may increase the amount of surface area in contact with the consumable 10. Additionally, the compression of the consumable 10 performed by the first and second flat sections 118, 120 may also, in some places, reduce or eliminate the presence of air between the surface of the consumable 10 and the first and second flat sections 118, 120. This may increase the amount of surface area in contact between these surfaces further. Since conductive heat transfer is proportional to the amount of surface area in contact between two thermally interacting bodies, this achieves an increased rate of heat flow to the consumable 10. In this way, efficient heat delivery from the heater 112 to the tobacco 12 inside the consumable 10 is ensured. Due to the compression of the consumable 10, heat may also be delivered to the centre of the consumable 10 more quickly, which may be beneficial in terms of aerosol quality. Heat is transferred from the first and second flat sections 118, 120 to the rest of the internal wall 104 by conduction, so that other sides of the consumable also receive heating. The inner face of the internal wall 104 is free of other components, thereby reducing the thermal mass of the heating apparatus and improving the speed of heating.

[0080] The heater 112 makes use of the available space inside the vacuum insulator 102 to reduce the diameter of the heating apparatus 100, and thus of an aerosol generating device incorporating the heating apparatus 100. In other known devices, a heating cup can be provided as a separate component within a central cavity of a vacuum insulator to secure a consumable in place and house a heating plate. Thus, the first and second flat sections 118, 120 of the present invention can further reduce the diameter of the heating apparatus by avoiding the need for such a heating cup.

[0081] While the heater 112 is operating, the vacuum 108 within the vacuum insulator 102 drastically inhibits the conductive escape of heat from the cavity 110. The vacuum insulator 102 also prevents heat from escaping via convection, except from via the opening 111. In this way, the cavity 110, the heater 112, and the vacuum insulator 102 form a highly efficient heating oven in which the tobacco 12 within the consumable 10 can be heated to a desired aerosol generating temperature. The controller may be configured to instruct the heater 112 to heat the tobacco to temperatures below the combustion temperature of tobacco. It may take several seconds for the cavity 110 to reach aerosol generating temperatures. As the tobacco 12 is heated, an aerosol is produced inside the cavity 110. The user can then inhale the aerosol by drawing air from the cavity 110 via the filter

14. This may draw air into the cavity 110 through a periphery of the opening 111 so that the user can continuously inhale aerosol from the cavity 110.

[0082] The internal wall 104 has a thickness of about 0.1 millimetres (mm) or less. Having a relatively low thickness reduces the thermal mass of the vacuum insulator 102, and increases the rate of heat conduction through the internal wall 104 to the cavity 110 and the consumable 10. In particular, less heat is conducted away from the cavity 110 by the outer face of the internal wall 104.

[0083] The threshold of 0.1 mm or less has been found to be significant in terms of improving the energy efficiency of the heating apparatus 100 by these mechanisms. In particular, an internal wall thickness of 0.1 mm has been found to have significantly improved thermal efficiency compared to an internal wall thickness of 0.25 mm.

[0084] In other embodiments, only the first flat section 118 and/or the second flat section 120 has a thickness of less than or equal to 0.1 mm and the remaining portions of the internal wall 104 can be thicker.

[0085] The external wall 106 has a thickness of about 0.25 mm, which may be preferable to a thickness of 0.1 mm to give the vacuum insulator 102 increased mechanical sturdiness and thermal insulation properties.

[0086] FIGS. 4A and 4B show a perspective view of a heating apparatus 200 for an aerosol generating device according to another embodiment of the invention. A heating apparatus 200 is provided and comprises a vacuum insulator 202, comprising an internal wall 204 and an external wall 206 between which a vacuum is enclosed. FIG. 4A shows the heating apparatus 200 as it would appear during use, while FIG. 4B shows the heating apparatus 200 with the external wall 206 removed so that the interior of the vacuum insulator 202 and the internal wall 204 can be viewed. Further, the heating apparatus 200 comprises a cavity 210, an opening 211, a heater 212, first and second electrical connections 214a, 214b, wires 216, a first flat section 218 and a second flat section (not shown), each of which are configured identically to the corresponding features of the heating apparatus 100.

[0087] The heating apparatus 200 differs from the heating apparatus 100 in that the external wall 206 of the vacuum insulator 202 comprises polyether ether ketone, or “PEEK”. This may be preferable in terms of device cost or weight. In some cases, using PEEK for the external wall 206 may reduce the amount of heat conducted from the internal wall 204 to the external wall 206 during operation of the heater 212. Additionally, the vacuum insulator 202 may comprise a seal 232 for joining the internal wall 204 to the external wall 206 while preventing the intrusion of air into the vacuum insulator 202. A further seal may be provided at other portions of the vacuum insulator 202 where the internal wall 204 and the external wall 206 are joined.

[0088] In other respects, the heating apparatus 100 and the heating apparatus 200 are configured in, and operate in, the same way.

[0089] FIG. 5 shows a cross-sectional schematic diagram of the heating apparatus 300 according to another embodiment of the invention. A heating apparatus 300 is provided and comprises a vacuum insulator 302, comprising an internal wall 304 and an external wall 306 between which a vacuum 308 is enclosed. The heating apparatus 300 further comprises a cavity 310, shown in FIG. 5 with the consumable 10 inserted therein, an opening 311, a heater 312, first

and second electrical connections 314a, 314b, wires (not shown), a first flat section 318, and a second flat section 320, each of which are configured identically to the corresponding features of the heating apparatus 100.

[0090] The heating apparatus 300 differs from the heating apparatus 100 in that the vacuum insulator 302 is tube-shaped rather than cup-shaped. As shown in FIG. 5, the cavity 310 comprises an additional opening 334, positioned distally to the opening 311. The opening 334 is blocked partially or fully by a plug 336 for stopping the consumable 10 from being inserted too far into the cavity 310. The plug 336 may comprise PEEK, rubber, or other suitable heat resistant materials.

[0091] The external wall 306 comprises stainless steel. In other embodiments, the external wall 306 could comprise PEEK and the vacuum insulator 302 may be provided with one or more seals, as described in relation to the vacuum insulator 202.

[0092] In other respects, the heating apparatus 100 and the heating apparatus 300 are configured in, and operate in, the same way.

[0093] The preferred thicknesses of the internal wall 104 and the external wall 106 discussed above also apply to the heating apparatus 200 and the heating apparatus 300, as well as embodiments discussed in relation to FIGS. 9 and 10.

[0094] FIG. 6 shows a perspective view of an alternative heater 412 that may be used in place of the heater 112. The heater 412 has a cylindrical shape and is configured to be provided on the outer face of the first flat section 118 and the outer face of the second flat section 118. The heater 412 is also configured to cover a substantially full circumference and longitudinal extent of the outer face 104a of the internal wall 104. This can improve the speed at which the cavity 110 reaches aerosol generating temperatures. The heater 412 comprises a winding resistive heating track that extends from a first end 413a to a second end 413b of the heater 412. The first and second ends 413a, 413b are configured to make electric connection with the first and second wire connectors 114a, 114b, which in turn connect to the wires 116.

[0095] Equally, the heater 412 may be used in place of the heater 212 or the heater 312 as part of the heating apparatus 200 or the heating apparatus 300, respectively.

[0096] FIG. 7 shows a cross-sectional schematic diagram of the heating apparatus 100 according to an alternative embodiment of the invention. FIG. 7 shows the heating apparatus 100 without the heater 112 and the wire connectors 114a, 114b for the purposes of illustration only. FIG. 7 shows an alternative positioning of the wires 116, wherein they are fed through a gap between the internal wall 104 and the external wall 106. The gap is provided adjacent to the opening 111. The opposite end of the vacuum insulator 102, through which the wires are positioned in the embodiment of FIGS. 1 to 3, is closed by the external wall 106. A seal 115a is provided within the gap to prevent air from entering the vacuum insulator 102 and to secure the wires 116 in place against the internal wall 104 and the external wall 106.

[0097] The seal 115a can comprise any suitable material, such as rubber, metal or heat resistant plastic.

[0098] The configuration of FIG. 7 can be particularly simple to manufacture. In some cases, this configuration also enables the wires 116 to have less contact with the internal wall 104 or the external wall 106. In turn, this reduces the amount of heat that escapes from the vacuum insulator 102 during use by conduction through the wires 116. The wires

**116** can have a single point of contact with the vacuum insulator **102** in this configuration.

**[0099]** The configuration of the wires **116** shown in FIG. **7** can also be implemented in the heating apparatus **200** or the heating apparatus **300**. Equally, this configuration of wires **116** could be implemented in any of the embodiments of the aerosol generating devices described further below in relation to FIGS. **9** and **10**.

**[0100]** FIG. **8** shows a cross-sectional schematic diagram of the heating apparatus **100** according to an alternative embodiment of the invention. FIG. **8** shows the heating apparatus **100** without the heater **112** and the wire connectors **114a**, **114b** for the purposes of illustration only. FIG. **8** shows an alternative positioning of the wires **116**, wherein they are fed through gaps in the curved longitudinal side of the external wall **106**. The gaps are provided towards the opening **111** to the cavity **110**. The wires **116** are sealed against the external wall **106** by seals **115b**, **115c**, which can comprise any suitable material, such as rubber, plastic or metal.

**[0101]** The configuration of FIG. **8** can be particularly compact and can enable the heating apparatus **100** to have a lower mass. This can be advantageous in terms of carrying weight for the user as well as for reducing the thermal mass of the device. Additionally, in this configuration the wires **116** have contact mainly with the external wall **106**, which generally reaches lower maximum temperatures than the internal wall **104** when the heater **112** is operating. In turn, this reduces the amount of heat that escapes from the vacuum insulator **102** during use by conduction through the wires **116**. In some implementations, having the wires **116** positioned towards the opening **111** may be advantageous in terms of arranging the heating apparatus **100** within an aerosol generating device. In other embodiments, the wires **116** and gaps could be provided at other locations on the external wall **106**.

**[0102]** The configuration of the wires **116** shown in FIG. **8** can also be implemented in the heating apparatus **200** or the heating apparatus **300**. Equally, this configuration of wires **116** could be implemented in any of the embodiments of the aerosol generating devices described further below in relation to FIGS. **9** and **10**.

**[0103]** In other embodiments, the vacuum insulator **102**, the vacuum insulator **202**, or the vacuum insulator **302** may instead be non-vacuum insulators, i.e., “insulators” containing an insulating medium such as air, fibrous or powdered insulators.

**[0104]** FIG. **9** shows a cross sectional schematic view of an aerosol generating device according to an embodiment of the invention. An aerosol generating device **500** is provided and comprises a vacuum insulator **502**, comprising an internal wall **504** and an external wall **506**, spaced radially apart from one another so that a vacuum **508** is enclosed between them. The aerosol generating device **500** comprises a cavity **510** that is provided adjacent the internal wall **504** and is configured to receive the consumable **10** comprising tobacco **12** and a filter **14**, as described previously. A housing **550** is provided and is configured to house the internal components of the aerosol generating device **500**. The vacuum insulator **502** is coupled to the housing **550** by support structures **552**. The vacuum insulator **502** is provided spaced apart from the housing **550** so that an air gap **553** is positioned between the housing **550** and the vacuum insulator **502**. Additionally, the aerosol generating device **500** comprises a button (not

shown) or other input mechanism and a controller (not shown), each of which are configured to enable the user to initiate the heater **512** in response to a press of the button.

**[0105]** The consumable **10** can be inserted into the cavity **510**, as shown in FIG. **9**, by a user via an opening **511** to the cavity **510** to be held in place by friction with the internal wall **504**. However, for clarity, the consumable **10** and the internal wall **504** are shown spaced apart in FIG. **9**. A resistive heater **512** is provided within the vacuum **508** and on the internal wall **504**. The heater **512** is configured to heat the internal wall **504** by conduction so that the internal wall **104** heats the consumable **10** and the air inside the cavity **510** by conduction and radiation. The heater **512** is powered by a battery (not shown) or any other power source provided within the aerosol generating device **500**, connected to the heater **512** by wires (not shown) and electrical connections (not shown), as described previously.

**[0106]** The internal wall **504** and the external wall **506** are joined by an annular first connecting wall **554** at a first longitudinal end **556** of the vacuum insulator **502**. The internal wall **504** and the external wall **506** are also joined by an annular second connecting wall **558** at a second longitudinal end **560** of the vacuum insulator **502**. The internal wall **504** of the vacuum insulator **502** comprises first and second flat sections (not shown) on which the heater **512** is provided, which are configured in the same manner as the first and second flat sections described previously with respect to the heating apparatus **100**.

**[0107]** The vacuum insulator **502** has a tubular shape that is open at both of the first and second longitudinal ends **556**, **560**, similarly to the heating apparatus **300**. The vacuum insulator **502** has a substantially circular or elliptical cross section when viewed parallel to its longitudinal axis. However, the vacuum insulator **502** may have other cross sections as described with respect to the vacuum insulator **102**. In the embodiment of FIG. **9**, the internal wall **504** and the external wall **506** are joined by annular first and second connecting walls **554**, **558**. However, in other embodiments, the external wall **506** could be joined directly onto the internal wall **504** or vice versa.

**[0108]** The heater **512**, the vacuum insulator **502**, and the cavity **510** are configured in, and operate in, the same manner as the heating apparatus **300**. However, the heater **512**, the vacuum insulator **502**, and the cavity **510** could also be configured in and operate in the same way as any of the alternative embodiments of the heating apparatus **100**, the heating apparatus **200** or the heating apparatus **300** described previously. In other example embodiments, the vacuum insulator **502**, the heater **512** and the cavity **510** could be configured in the same way as similar heating apparatuses already known in the art. For example, the heater **512** may be provided within the cavity **510** rather than within the vacuum **508**, or may not be provided directly on the internal wall **504**.

**[0109]** The housing **550** comprises metal, plastic, or any other suitable material for housing components of the aerosol generating device. The housing **550** also comprises and an opening **509** aligned with the opening **511** of the vacuum insulator **502** for receiving the consumable **10**.

**[0110]** The support structures **552** comprise struts or rods that are connected to the external wall **506** at one end and the housing **550** at the other end to attach the vacuum insulator **502** to the housing **550**. In other embodiments, the support structures **552** could be structures forming an integral part of

the housing **550** that are coupled to the vacuum insulator **502** by a locking or attachment mechanism.

[0111] Now, an example use of the aerosol generating device **500** will now be described with reference to FIG. **9**. A user can insert the consumable **10** into the cavity and press the button. The controller then enables power to flow from the battery to the heater **512** provided on the internal wall **504**. The heater **512** then begins to heat the internal wall **504** by conduction and radiation. This heat is transferred through the internal wall **504** to the cavity **510** and the tobacco **12** received therein. The cavity **510** is insulated by the vacuum insulator **502**, which drastically inhibits the escape of heat from the cavity **510**. The tobacco **12** is then gradually heated to aerosol generating temperatures, which may be below the combustion temperature of the tobacco **12**. This allows the aerosol generating device **500** to function as a heat-not-burn device. The user can then inhale the aerosol generated inside the cavity **510** via the filter **14**.

[0112] As the heater **512** heats the cavity **510** via the internal wall **504**, heat is also transferred, or diffuses, primarily by conduction, to other parts of the vacuum insulator **502**. For example, heat is transferred by conduction along the internal wall **504** towards the first longitudinal end **556** to the first connecting wall **554**, which transfers heat in turn to the external wall **506**. The same process occurs towards the second longitudinal end **560**, wherein heat is transferred to the external wall **506** via the second connecting wall **558**. In this way, heat emitted from the heater **512** follows a “conduction path” through physically connected components to other regions of the vacuum insulator **502** and the aerosol generating device **500**.

[0113] As heat diffuses from the internal wall **504** across the vacuum insulator **502**, heat is continually carried away from the surface of the vacuum insulator **502** by convection and radiation processes. Consequently, regions of the vacuum insulator **502** further from the heater **512**, in terms of the shortest available conduction path to that region from the heater **512**, receive progressively less heat from adjacent regions closer to the heater **512**. In other words, regions of the vacuum insulator **502** connected to the heater **512** by a longer conduction path length receive less heat from the heater **512**. It has been found that some regions of the external wall **506**, in use, reach significantly lower maximum temperatures, or equivalently receive significantly less heat, over the course of a vaping session than other regions of the external wall **506**.

[0114] The embodiment of FIG. **9** makes use of this finding by connecting the support structures **552** to the external wall **506** at a region generally corresponding to the coldest region of the vacuum insulator **502** in use. This minimises the amount of heat that is lost via conduction through the support structures **552** to the housing **550**. In turn, this minimises the temperature of the housing **550** during operation of the aerosol generating device **500**. More specifically, the support structures **552** are provided attached to the vacuum insulator **502** at a position on the vacuum insulator **502** that maximises the shortest conduction path length available from the heater **512** to the support structures **552**. This maximises the amount of heat that dissipates from the vacuum insulator **502** by radiation and convection before reaching the support structures **552**. In turn, this minimises the temperature of the housing **550** during operation of the aerosol generating device **500**.

[0115] In the embodiment of FIG. **9**, heat is conducted to the external wall **506** via the first and second connecting walls **554**, **558**. Therefore, the hottest regions of the external wall **506** in use are found towards the first and second longitudinal ends **556**, **558** of the vacuum insulator **502**. Conversely, the coldest region is found in the middle of the external wall **506**, which has a maximum conduction path length to the heater **512**. The support structures **552** are attached accordingly to the external wall **506** in a middle portion of the external wall **506** approximately half way between the first and second longitudinal ends **556**, **558**, as shown in FIG. **9**.

[0116] In other embodiments, however, the particular location of the coldest region on a vacuum insulator in use will generally depend on the particular arrangement, orientation, and geometry of the aerosol generating device **500**. In particular, the coldest region will depend on the shape, relative positions, and materials of the vacuum insulator and the heater. In other embodiments, the support structures **552** may be provided on the vacuum insulator **502** wherever the coldest region in use may be found.

[0117] In some cases, it may be impractical to attach the support structures **552** to the vacuum insulator **502** at the region of the vacuum insulator **502** that is the absolute coldest region of the vacuum insulator **502** in use. For example, it may be difficult to attach the support structures **552** in this way while ensuring a secure mechanical coupling between the vacuum insulator **502** and the housing **550**. Consequently, the conduction path length from the heater **512** to the support structures **552** may only be maximised as far as possible while meeting other competing design demands of the aerosol generating device **500**. In other words, it may not be practically possible to position the support structures **552** to maximise fully the shortest available conduction path from the heater **512** to the support structures **552**. Nevertheless, the conduction path length can be maximised as far as possible. One such embodiment is described further below with respect to FIG. **10**.

[0118] The conduction path length could be increased in various ways. For example, the conduction path length could be increased by increasing the physical distance along the surface of the vacuum insulator **502** through which the heat must travel to reach the support structures **552**, such as in the embodiment of FIG. **9**. However, in other embodiments, the conduction path length may be increased using an increased “effective length” rather than an increased physical length. For example, the first connecting wall **556** could instead comprise a different, more insulating material that is a poorer conductor of heat. This would effectively increase the conduction path length along the connecting wall **554** by a factor roughly corresponding to a ratio of the thermal conductivities of the new insulating material and the original material. If the material used for the second connecting wall **558** is not also switched to the more insulating material, then this would have the effect of shifting the region of maximum conduction path length to the heater towards the first longitudinal end **556**. In that case, the support structures **552** could be shifted accordingly towards the first longitudinal end **556**. In other examples, the conduction path length could be effectively increased by decreasing the thickness of the vacuum insulator **502** in certain places to reduce the rate of heat flow through the vacuum insulator **502** through those places.

[0119] In the embodiment of FIG. 9, the air gap 553 between the external wall 506 also helps to insulate the housing 550 from the external wall 506. The support structures 552 comprise rods or struts, which may have a lower cross sectional area than other forms of support structures. This can further reduce the rate of heat transfer to the housing 550.

[0120] FIG. 10 shows a cross sectional schematic view of an aerosol generating device according to an embodiment of the invention.

[0121] An aerosol generating device 600 is provided and comprises a vacuum insulator 602, comprising an internal wall 604 and an external wall 606, spaced radially apart from one another so that a vacuum 608 is enclosed between them. The aerosol generating device 600 differs from the aerosol generating device 500 in that the vacuum insulator 602 has a closed end. Thus, the vacuum insulator 602 has a cup-shaped cross section when viewed from the perspective of FIG. 10, similar to the heating apparatus 100. The external wall 606 and the internal wall 604 are connected only by an annularly shaped first connecting wall 654 at a first longitudinal end 656. The curved external wall 606 is closed by a substantially circular second connecting wall 658 at a second longitudinal end 660 of the vacuum insulator 602. The aerosol generating device 600 also comprises support structures 652, which differ from the support structures 552 in that they are positioned towards the second end 660 of the vacuum insulator 602.

[0122] In other respects, the aerosol generating device 600 and the aerosol generating device 500 are configured in, and operate in, the same way. That is, the aerosol generating device 600 further comprises a cavity 610 configured to receive a consumable 10 through an opening 611, a housing 650 with an opening 609, an air gap 653, a button (not shown) or other input mechanism, a controller (not shown), and a resistive heater 612. The heater 612 is powered by a battery (not shown) or any other power source provided within the aerosol generating device 600, connected to the heater 612 by wires (not shown) and electrical connections (not shown). These features of the aerosol generating device 600 are configured identically to the corresponding features of the aerosol generating device 500.

[0123] Returning to the vacuum insulator 602, the external wall 606 and the internal wall 604 are only connected by the supporting wall 654, which is provided towards the first end 656. Consequently, during use, heat transported from the heater 612 to the support structures 652 by conduction must travel up the internal wall 604 towards the first end 656 of the vacuum insulator 602. Next, the heat can conduct to the supporting wall 654 before travelling down the external wall 606 towards the second connecting wall 658. During this time, heat is continuously lost from the external wall 606 by convection and radiation. Accordingly, less heat reaches the second connecting wall 658 compared to the first connecting wall 654 and regions of the external wall 606 towards the first end 656. Thus, the coldest region of the vacuum insulator 602 in use is generally the second connecting wall 658, which has a maximum conduction path length from the heater 612.

[0124] For structural or other practical reasons, it may be less desirable to attach the vacuum insulator 602 to the housing 650 only at the connecting wall 658. For example, it may be difficult to achieve a secure attachment of the vacuum insulator 602 to the housing 650 by attaching the

support structures 652 only to the second connecting wall 658. Therefore, in this embodiment the support structures 652 are attached to the external wall 606 only towards the second end of the vacuum insulator 660, as shown in FIG. 10. This maximises the conduction path length to the support structures 652 while balancing the competing demand of producing a robust aerosol generating device.

[0125] In other embodiments, it may be possible to provide the support structures 652 on the supporting wall 658 to maximise the conduction path length more fully.

[0126] In other embodiments, the vacuum insulator 502 or the vacuum insulator 602 may instead be non-vacuum insulators, i.e., “insulators” containing an insulating medium such as air, fibrous or powdered insulators. If the insulators 502, 602 contain a non-gaseous insulating medium, heat may travel directly towards support structures 552, 652 through the non-gaseous medium. Thus, in this case the support structures 552, 652 may be positioned as distantly as possible from the heaters 512, 612 in the aerosol generating device 500 and the aerosol generating device 600. In the case where the insulating medium is a gas, the support structures 552, 652 may have a similar positioning to the above embodiments using a vacuum. Alternatively, the support structures 552, 652 may have a similar positioning to embodiments using a non-gaseous insulating medium, depending on the geometry of the insulators.

1. A heating apparatus for an aerosol generating device, comprising:

- an insulator, comprising an internal wall and an external wall that are separated from one another;
- a cavity configured to receive an aerosol forming substance, positioned adjacent the internal wall of the insulator; and
- a heater provided inside the insulator in thermal contact with the internal wall of the insulator, configured to heat an aerosol forming substance received in the cavity by thermal conduction to generate an aerosol; wherein the internal wall comprises a substantially flat section, the substantially flat section comprising an inner face configured to compress a consumable comprising the aerosol forming substance when the consumable is received in the cavity, and an outer face on which the heater is provided.

2. The heating apparatus of claim 1, wherein the internal wall and the external wall are separated by a vacuum such that the insulator is a vacuum insulator.

3. The heating apparatus of claim 1, wherein the substantially flat section extends along a longitudinal axis of the insulator.

4. The heating apparatus of claim 3, wherein the heater extends longitudinally on the outer face of the substantially flat section.

5. The heating apparatus of claim 1, wherein the internal wall is substantially cylindrical, and wherein the heater is provided on the internal wall around a substantially full circumference of the internal wall.

6. The heating apparatus of claim 1, wherein the heater is provided only or predominantly on the substantially flat section.

7. The heating apparatus of claim 1, wherein the internal wall comprises a plurality of substantially flat sections, the plurality of substantially flat sections each comprising a respective inner face configured to compress the consumable

when the consumable is received in the cavity, and a respective outer face on which the heater is provided.

**8.** The heating apparatus of claim **1**, wherein the insulator comprises a flared opening configured to enable the consumable to be received in the cavity.

**9.** The heating apparatus of claim **1**, wherein the heater comprises an exposed external surface having a material susceptible to an oxidation reaction in the presence of oxygen.

**10.** The heating apparatus of claim **1**, wherein the internal wall has a thickness of 0.1 mm or less.

**11.** The heating apparatus of claim **1**, further comprising one or more wires configured to connect the heater to a power source, wherein the one or more wires are positioned through one or more gaps provided on a longitudinal face of the external wall, or positioned through one or more gaps in the insulator provided at a longitudinal end of the insulator, adjacent an opening to the cavity.

**12.** The heating apparatus of claim **1**, further comprising an electrical insulation layer provided between the heater and the internal wall.

**13.** An aerosol generating device configured to generate an aerosol for inhalation by a user, comprising the heating apparatus of claim **1**.

**14.** The aerosol generating device of claim **13**, further comprising a housing configured to house components of the

aerosol generating device, and one or more support structures attached to the insulator to couple the insulator to the housing;

wherein the one or more support structures are positioned on the insulator to maximise a length of a conduction path from the heater to the one or more support structures.

**15.** An aerosol generating device configured to generate an aerosol for inhalation by a user, comprising:

a heater configured to heat an aerosol forming substance received within the aerosol generating device;

a housing configured to house components of the aerosol generating device;

an insulator configured to insulate the housing from heat produced by the heater; and

one or more support structures attached to the insulator to couple the insulator to the housing;

wherein the one or more support structures are positioned on the insulator to maximise a length of a conduction path from the heater to the one or more support structures; and

wherein the insulator is coupled to the housing only by the one or more support structures.

\* \* \* \* \*