

H. C. DIXON.

Improvement in Metallic-Straps for Packing-Boxes.

No. 131,605.

Patented Sep. 24, 1872.

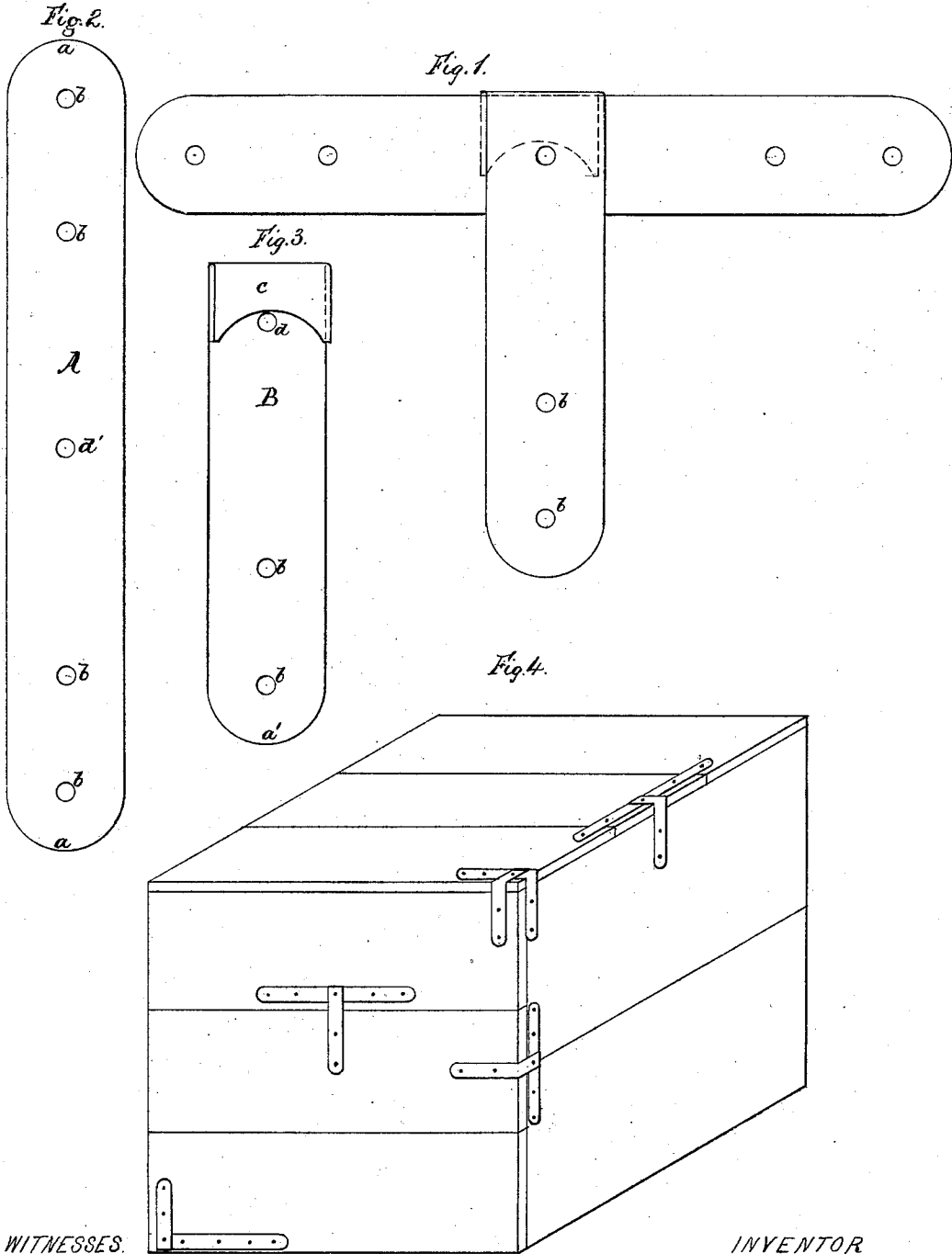

WITNESSES.

*M. M. Livingston*  
*T. J. Beecher*

INVENTOR

*H. C. Dixon*

# UNITED STATES PATENT OFFICE.

HENRY C. DIXON, OF BROOKLYN, NEW YORK.

## IMPROVEMENT IN METALLIC STRAPS FOR PACKING-BOXES.

Specification forming part of Letters Patent No. 131,605, dated September 24, 1872.

*To all whom it may concern:*

Be it known that I, HENRY C. DIXON, of Brooklyn, in the county of Kings and State of New York, have invented a new and Improved Metallic Strap for Packing Boxes or Cases; and I hereby declare that the following is a full, clear, and exact description thereof, reference being had to the accompanying drawing which forms part of this specification.

It is customary to strengthen packing boxes or cases containing goods by bending and nailing wooden or metal hoops around the boxes or cases, usually over the edges where the boards are nailed together to form the box or case. Such hoops are generally carried entirely around the box, but sometimes merely short strips of hoop-iron, crossing each other at right angles and bent down upon and nailed to the sides at the corners of the box or case, are used. These hoops, passing entirely around the box or only applied at the corners, are clumsy and laborious to apply, and present sharp corners or rough edges to injure the hands of those who handle the boxes or cases during transportation, and to tear the clothes of persons passing by them.

My present invention consists in the new article of manufacture of a metallic strap for packing boxes or cases, consisting of two parts, constructed and adapted for use as will be hereinafter fully described.

In the accompanying drawing, Figure 1 is a plan or top view of my improved metallic strap in position for being secured to a box at one corner to serve as a metallic corner piece; Figs. 2 and 3 are plan or top views of the straps disconnected from each other; and Fig. 4 illustrates several different ways of putting my invention into practical use or operation.

A designates the longer and B the shorter metallic strap. These straps are designed to be made of hoop-iron, and are preferably provided with rounded ends, as shown at *a a'*, thereby relieving the strap of the liability incident to other straps of a rectangular corner turning outward to tear the clothes or injure the hands of those handling or coming in contact with a packing-case during transportation. The straps are provided with the requisite number of properly-punched holes; and I find

in practice that two holes, *b b*, (see Figs. 2 and 3,) in the ends or legs of the straps will be sufficient; but I do not confine myself to any particular number of holes. The strap B is shown as provided with a looped or hooked end, *c*, (see Figs. 1 and 3, showing, respectively, opposite sides of said strip,) for catching under the strap A when the straps are to be put into use, and as also provided with a hole, *d*, which registers with a hole, *d'*, in the strap A when the strap B is hooked under the strap A, as shown in Fig. 1. Of course it will be understood that the several holes punched through the straps are to receive screws or nails for securing the strap to the box or packing-case. The hook *c* serves important offices. It enables the workmen strapping the packed boxes or cases to quickly cause the holes *d d'* to register with each other; and it serves, in conjunction with, say, a single nail or screw, to securely hold the straps at the starting-point, and there is little liability of either strap springing up at this point. In some cases this hook *c* may be dispensed with, and the end, which would otherwise carry it, be rounded or smoothed, so as to leave no rough edges or sharp corners to tear the clothing or injure the hands during the handling and transportation of the case or box; and in this connection I will again remark that I am aware that two strips of hoop-iron, crossing each other at the corners of a box, and the ends bent down and over on the sides of the box, have long been in use; but I am not aware that two straps with holes punched in them, and the one provided with a hook, *c*, nor that regularly-prepared straps with holes already punched in them for the nails or screws and with rounded corners, have ever been produced as a new article of manufacture ready for use.

In Fig. 4 my improved strap is shown as applied to a packing case or box in various ways for strengthening it at different parts.

My invention provides an article for strapping packing cases and boxes, which can be applied by any person quickly and easily; and by its use the laborious task of bending hoop-iron around boxes, and cutting off the iron as required, and punching the holes in the same by hand—usually at the time the nails are about to be inserted—is dispensed with, and

a convenient and much-needed article, occupying but little room and inexpensive in comparison with the cost of and time consumed in applying hoop-iron or wooden hoops, as at present practiced, is placed in the hands of merchants and others.

What I claim as my invention, and desire to secure by Letters Patent, is—

The new article of manufacture of the me-

tallic strap, consisting of the parts A B, either with or without the hook c, constructed and adapted for use substantially as and for the purposes herein specified.

HENRY C. DIXON.

Witnesses:

M. M. LIVINGSTON,

T. B. BEECHER.