



- (51) International Patent Classification:  
A46B 15/00 (2006.01) A61C 17/22 (2006.01)
- (21) International Application Number:  
PCT/IB2012/000711
- (22) International Filing Date:  
5 April 2012 (05.04.2012)
- (25) Filing Language: Italian
- (26) Publication Language: English
- (30) Priority Data:  
PN2011U000034 22 November 2011 (22.11.2011) IT
- (71) Applicant (for all designated States except US): LUX  
MIRABILIS DI FAVERO NICOLA [IT/IT]; Piazza del  
Cristo n.12, I-33170 Pordenone (IT).
- (72) Inventor; and
- (75) Inventor/Applicant (for US only): FAVERO, Nicola  
[IT/IT]; Via Rovereto n°2, I-33170 Pordenone (IT).
- (74) Agent: DALLA ROSA, Adriano; Via del Troi n.2, I-  
33170 Pordenone (IT).

(81) Designated States (unless otherwise indicated, for every kind of national protection available): AE, AG, AL, AM, AO, AT, AU, AZ, BA, BB, BG, BH, BR, BW, BY, BZ, CA, CH, CL, CN, CO, CR, CU, CZ, DE, DK, DM, DO, DZ, EC, EE, EG, ES, FI, GB, GD, GE, GH, GM, GT, HN, HR, HU, ID, IL, IN, IS, JP, KE, KG, KM, KN, KP, KR, KZ, LA, LC, LK, LR, LS, LT, LU, LY, MA, MD, ME, MG, MK, MN, MW, MX, MY, MZ, NA, NG, NI, NO, NZ, OM, PE, PG, PH, PL, PT, QA, RO, RS, RU, RW, SC, SD, SE, SG, SK, SL, SM, ST, SV, SY, TH, TJ, TM, TN, TR, TT, TZ, UA, UG, US, UZ, VC, VN, ZA, ZM, ZW.

(84) Designated States (unless otherwise indicated, for every kind of regional protection available): ARIPO (BW, GH, GM, KE, LR, LS, MW, MZ, NA, RW, SD, SL, SZ, TZ, UG, ZM, ZW), Eurasian (AM, AZ, BY, KG, KZ, MD, RU, TJ, TM), European (AL, AT, BE, BG, CH, CY, CZ, DE, DK, EE, ES, FI, FR, GB, GR, HR, HU, IE, IS, IT, LT, LU, LV, MC, MK, MT, NL, NO, PL, PT, RO, RS, SE, SI, SK, SM, TR), OAPI (BF, BJ, CF, CG, CI, CM, GA, GN, GQ, GW, ML, MR, NE, SN, TD, TG).

Published:

— with international search report (Art. 21(3))

(54) Title: ORAL CARE SYSTEM COMPRISING A TOOTHBRUSH WITH GERMICIDAL LED

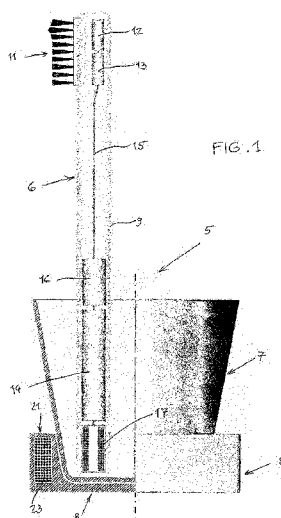

(57) Abstract: Protection for the dental hygiene and the asepsis of the oral cavity, adapted to be used by anybody and performing the function to clean the teeth, by sterilizing the same and the oral cavity. Protection comprising a tooth-brush (6), a glass or receptacle (7) for containing the tooth-brush (6) and a lower supporting base (8) to laid the glass or receptacle (7) thereon. Protection in which the tooth-brush (6) includes internally a LED (12) emitting an ultraviolet radiation for sterilizing, a LED (13) emitting a blue light in the visible spectrum, an electronic control device (16), a storage battery (14) for supplying the LED (12, 13) and the other electric components of the tooth-brush, and a re-charging circuit (17) inductively coupled to a solenoid (23) housed into the supporting base (8), for charging automatically the storage battery (14) when the tooth-brush (6) is put into the glass or receptacle (7).



## ORAL CARE SYSTEM COMPRISING A TOOTHBRUSH WITH GERMICIDAL LED

The invention relates to a protection for the dental hygiene and the asepsis of the oral cavity, which is constructed and used in a simple manner, and is adapted to be used by anybody and performs the function to clean the teeth, by sterilizing the same and the oral cavity.

It is well known that for having a correct oral hygiene and an asepsis of the oral cavity it is necessary to use the tooth-brush correctly every day with suitable toothpastes and to use proper germicidal mouthwash and also that, after each tooth-brush has been used, it is necessary to clean or sterilize every day with proper technical provisions the same tooth-brush, which condition should be kept daily for obtaining the scope as above described. However, the experience shows that often such operations aren't performed for negligence or forgetfulness, or they are performed in an inadequate way, and in such cases the lacked cleaning of the teeth may involve on the time the risk of holes or other pathologies of the same teeth and/or the gums, while the lacked or not correct performed cleaning of the tooth-brush, in which many bacteria are hidden, involves unavoidably a diffusion of the bacteria in the oral cavity when the tooth-brush is subsequently used, with consequent risk of arising of undesired pathologies in the course of time.

The object of the present invention is to eliminate the drawbacks caused by the not correct performed or the lacked dental hygiene and/or cleaning of the tooth-brush after each use thereof, by means of a protection for the dental hygiene and the asepsis of the oral cavity, which is made with the characteristics which will be described and is adapted to provide for, during each treatment of the teeth, not only the cleaning thereof but also a contemporaneous hygienic sterilization of the same teeth and the oral cavity, with consequent considerable shortening of the treatment times.

This protection for the dental hygiene and the asepsis of the oral cavity is made with the constructive characteristics which will substantially described, with particular reference to the attached claims. The present invention will be better understood by the following description, given by way of not-limiting example only and with reference to the

5 accompanying drawings, in which :

- Fig. 1 shows a front view of the protection according to the invention, comprising a tooth-brush as it will be described, which is introduced into a containing glass supported by a lower supporting base ;

10 - Fig. 2 shows a cutaway and enlarged front view of the containing glass of Fig. 1, without the tooth-brush ;

- Fig. 3 shows a schematic and cutaway side view of the tooth-brush of the protection of Fig. 1 ;

- Fig. 4 shows a schematic and cutaway front view of the tooth-brush of Fig. 3.

The above mentioned Figures represent a protection 5 according to the invention, for the dental hygiene and the asepsis of the oral cavity, which is constructed and used in a simple manner, and is adapted to be used by anybody and performs the double function of cleaning the teeth, by sterilizing the same and the oral cavity.

With reference to Fig. 1, it is noted that the protection 5 is substantially constituted by a tooth-brush 6 which is made as it will be described, by a glass or other receptacle 7 for containing the tooth-brush 6, and by a lower supporting base 8, on to which the glass or  
20 receptacle 7 is laid and put, and which includes the electric components which will be described, which are connected with an electric cable (not indicated) connectable to the electric supply line.

As particularly visible from the Figs. 3 and 4, the tooth-brush 6 of the protection 5 is  
25 composed of a classic flat lengthened body 9, made of an internally hollow plastic

material, or other suitable material, to the upper end portion 10 of which a brush 11 of traditional type for cleaning the teeth is housed with a joint, which brush is of removable type and adapted to be easily replaced if it is needed, for example in the case in which it has some signs of evident wearing and loss of the mechanical characteristics of the bristles  
5 of the same brush.

Such lengthened body 9 is provided in the interior of a first and a second illuminating electric component 12, 13, arranged closer and overlapped to each other and in correspondence of said brush 11, in a back position of the same brush, of which the first upper component 12 is formed by a LED adapted to emit an ultraviolet radiation with  
10 germicidal function, while the second lower component 13 is constituted by a further LED adapted to emit a blue light in the visible spectrum. Such components are supplied autonomously by an energy storage battery 14, also included in the interior of the body 9 of the tooth-brush 6 and connected thereto and to additional electrical components as it will be described. The LED 13 performs the following functions : when it is switched on  
15 continuously it indicates that the LED 12 of the ultraviolet radiation is switched on and therefore performs its germicidal and sterilizing function ; when it is switched on intermittently it indicates that the re-loading step of the storage battery 14 is being performed, in the manners which will be described. Such first and second electric components 12 and 13 are supplied electrically through a lead 15, inserted longitudinally in  
20 the interior of the body 9, and connected to both the components 12 and 13 and to a control device 16 in series with the energy storage battery 14 of the re-chargeable type and a re-charging circuit 17, which are inserted in succession on the opposite and lower end portion 18 of the same body. The purpose of the storage battery 14 is to provide for an autonomous low DC electric supply voltage to the control device 16 and the illuminating components  
25 12 and 13. In turn, the control device 16 is of electronic type and is provided with a

movement sensor (not shown), and serves for activating and de-activating automatically the operation of said first and second electric components 12 and 13, in the manner which will be described, respectively when the tooth-brush 6 is used or isn't used.

By referring now to the Fig. 2, in which a front cutaway view of a portion of the glass or  
5 containing receptacle 7 of the tooth-brush 6 and the lower supporting base 8 is shown, on to which base such glass or receptacle 7 is laid, it is noted that such supporting base 8 has a flat form delimiting a flat bottom 19 on to which the bottom 20 of the glass or receptacle 7 is laid, which bottom 19 is joined to a side raised edge 21, in the interior of which a solenoid 23 is inserted, which is connected through the electric cable to the electric supply  
10 voltage. The glass or receptacle 7 is made preferably of plastic or glass, and the tooth-brush 6, when isn't used in the rest step thereof, is put therein.

As visible particularly in the Fig. 1, such solenoid 23 is arranged in such a manner that to be situated in a position correspondent to and slightly spaced away from the position in which the re-charging circuit 17 is housed into the body 9 of the tooth-brush 6, and in this  
15 way the solenoid 23 is coupled inductively with the same re-charging circuit, and under this condition when such solenoid is supplied by the electric supply line through the electric cable, it is able to transmit to the re-charging circuit 17 the electric energy by means of the inductive coupling between these two component parts, so as to determine by the re-charging circuit 17 the charging of the storage battery 14 without any direct  
20 electrical/mechanical connection. Such re-charging of the storage battery 14 may therefore be effected only when the glass or receptacle 7 is introduced into the supporting base 8 and the tooth-brush 6 is introduced, before of after the use thereof, into the glass or receptacle 7, in a pre-established position in which its re-charging circuit 17 be arranged in a position correspondent to that of the solenoid 23 of the supporting base 8, in a manner that in the re-  
25 charging circuit 17 there is transferred by means of induction the electric energy from the

solenoid 23, when this latter is supplied by the electric supply line, under the condition in which the re-charging circuit 17 provided for re-charging the energy storage battery 14.

Whenever the tooth-brush 6 is drawn from the glass or receptacle 7 for being utilized, the above mentioned movement sensor (not shown) is actuated automatically into such a

5 condition that to be able to activate the control device 16, which is supplied by the storage battery 14, and such control device 16 in turn provides for switching on both the LED diodes 12 and 13, with consequent emission of the ultraviolet radiation by the first LED 12 and blue light in the visible spectrum by the second LED 13. As long as the tooth-brush 6 is used, and therefore the movement sensor detects the movement of the same tooth-brush,

10 both the LED 12 and 13 are operating and are supplied by the storage battery 14.

When the use of the tooth-brush is terminated, and as soon as it has been put in its rest position into the glass or receptacle 7, after a pre-established delay time the movement sensor detects the not-moving condition of the tooth-brush, and is actuated automatically in the de-activating condition of the control device 16, so that this latter switches off the LED

15 12 and 13, so as the first LED 12 ceases to emit the ultraviolet radiations , while the second LED 13 changes its state namely stays on intermittently, for indicating that the tooth-brush is in the rest position and the storage battery 14 is charged automatically through the solenoid 23 and the re-charging circuit 17. Thanks to the presence of the LED 12 emitting ultraviolet radiations of the present protection, it is so possible to achieve,

20 contemporaneously to the dental hygiene action, also a sterilizing and germicidal action, with consequent asepsis of the oral cavity and the tooth-brush, in a way not to be obliged to use each time some germicidal mouthwashes, to clean the tooth-brush each time its use is terminated or to sterilize the same with specific apparatuses, and with consequent drastic shortening of the times spent by the users for the oral hygiene, and increase of the

25 effectiveness of these actions without using additional products and/or apparatuses

involving also a further cost. Moreover, the glass or receptacle 7 has also the function to collect any possible water dripping which should percolate from the protection, and it can be removed and cleaned.

## CLAIMS

1. Protection for the dental hygiene and the asepsis of the oral cavity, adapted to be used by anybody and performing the function to clean the teeth, by sterilizing the same and the oral cavity, comprising a tooth-brush (6), a glass or other containing receptacle (7), and a lower supporting base (8), said tooth-brush being composed of a classic flat lengthened body (9),  
5 made of an internally hollow plastic material, or other suitable material, to the upper end portion (10) of which a brush (11) of traditional type for cleaning the teeth is housed, said tooth-brush being adapted to be introduced into said glass or receptacle (7), when it isn't used, characterized in that said lengthened body (9) is provided in the interior of a first and  
10 a second illuminating electric component (12, 13), arranged closer and overlapped to each other and in correspondence of said brush (11), in a back position of the same brush, of which the first upper component (12) is formed by a LED diode adapted to emit an ultraviolet radiation with germicidal function, while the second lower component (13) is constituted by a further LED diode adapted to emit a blue light in the visible spectrum, said  
15 first and second components (12, 13) being supplied by an electric storage battery means (14) of re-chargeable type, through electronic control means (16) provided with movement sensor means, and re-charging means (17) for said electric storage battery means (14), and characterized in that said glass or receptacle (7) is laid with its bottom (20) on to the bottom (19) of said lower supporting base (8), which bottom is joined to a side raised edge  
20 (21), in the interior of which inductive coupling means such as a solenoid (23) are inserted, which are connected through an electric cable to the electric supply voltage, said glass or receptacle (7) being made preferably of plastic or glass, and said inductive coupling means (solenoid 23) being arranged in such a manner that to be situated in a position correspondent to and slightly spaced away from the position in which said re-charging  
25 means (17) are housed into the body (9) of the tooth-brush (6), and being coupled

inductively with said re-charging means (17), under this condition when said inductive coupling means (23) are supplied by the electric supply line they are able to transmit to said re-charging means (17) the electric energy for determining by these latter the charging of said electric storage battery means (14), without any direct

5 electrical/mechanical connection, such re-charging of said electric storage battery means (14) being effected only when the glass or receptacle (7) is introduced into said supporting base (8) and the tooth-brush 6 is introduced, before of after the use thereof, into the glass or receptacle (7), in a position in which its re-charging means (17) are arranged in a position correspondent to that of said inductive coupling means (23), and characterized in

10 that whenever the tooth-brush (6) is drawn from the glass or receptacle (7) for being utilized, said movement sensor is actuated automatically into such a condition that to activate said control means (16) to switch on both said LED diodes (12, 13), with consequent emission of the ultraviolet radiation by the first LED (12) and blue light in the visible spectrum by the second LED (13), which LED (12, 13) are switched on as long as

15 the tooth-brush is used, and therefore the movement sensor detects the movement of the same tooth-brush, and are switched off by said control means (16) when the use of the tooth-brush is terminated, and as soon as it has been put in its rest position into the glass or receptacle (7), so that after a pre-established delay time said movement sensor detects the not-moving condition of the tooth-brush, and is actuated automatically in the de-activating

20 condition of said control means (16).

2. Protection according to claim 1, characterized in that when the LED diode of said second component (13) is lighted up it indicates that the LED diode of said first component (12) is switched on and therefore performs its germicidal and sterilizing function, while when it is lighted up intermittently, it indicates that said electric storage battery means (14)

are charged and the tooth-brush (6) is in the rest position, inserted into the glass or receptacle (7).

5

10

15

20

25

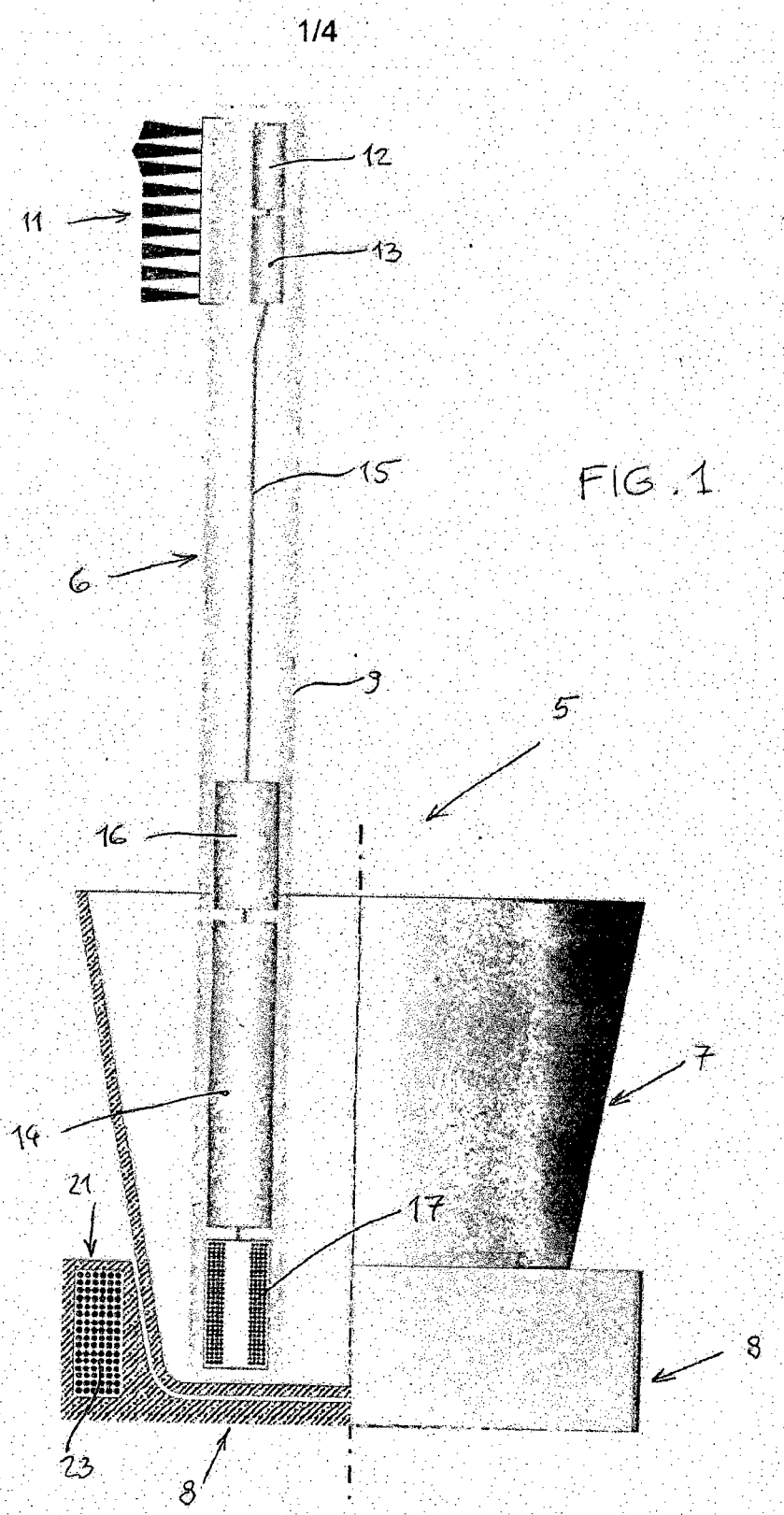

2/4

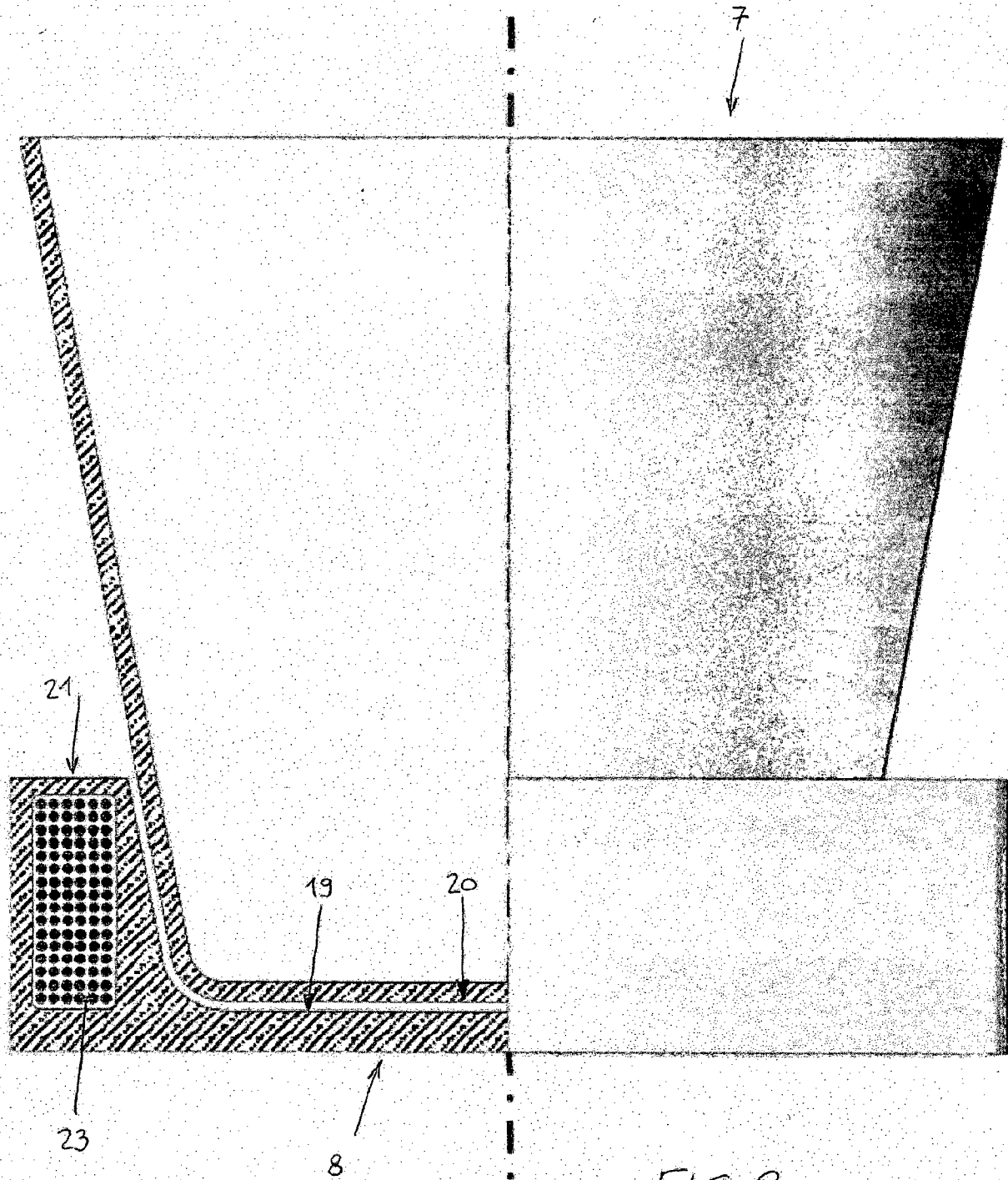
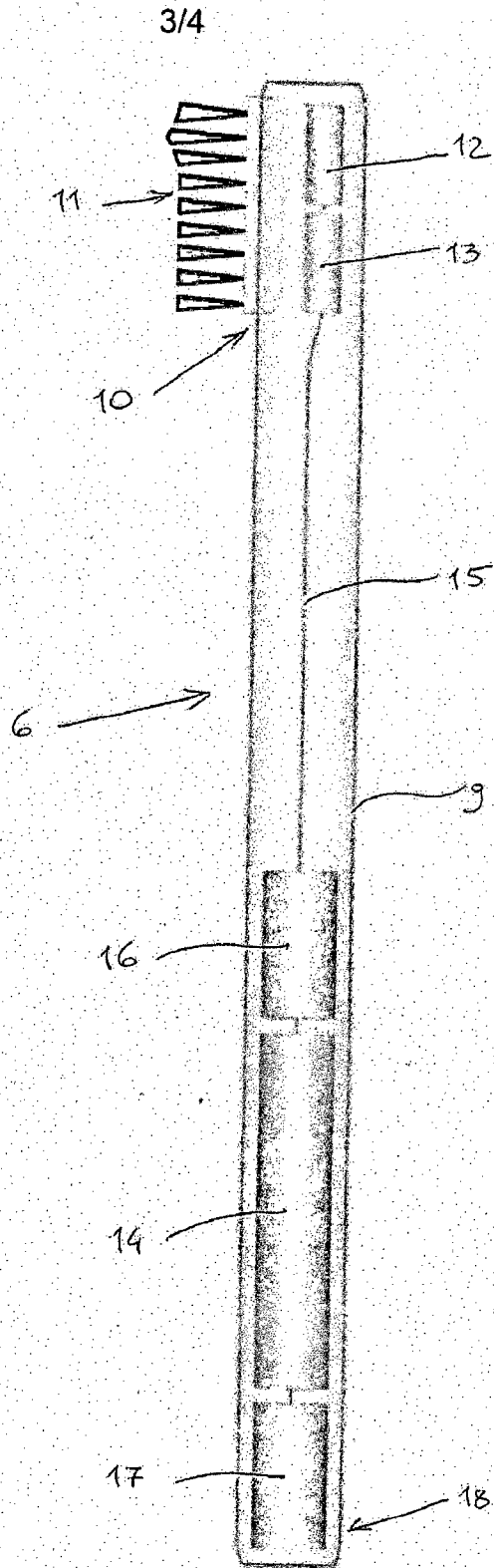

FIG. 2



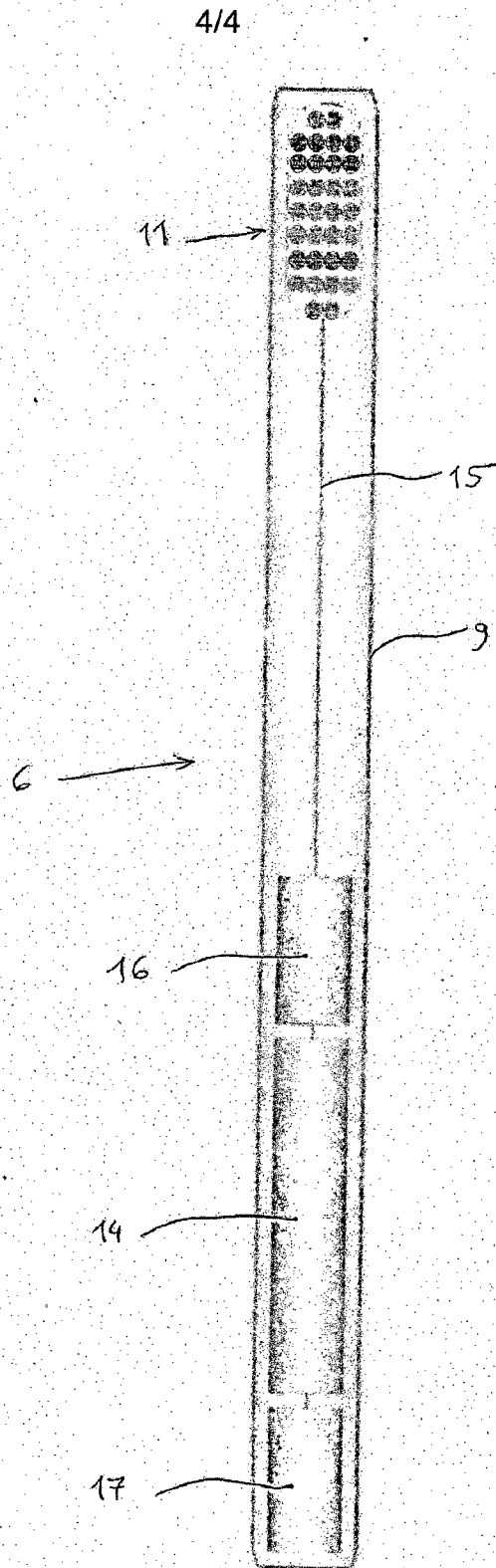

FIG. 4

## INTERNATIONAL SEARCH REPORT

International application No  
PCT/IB2012/000711

A. CLASSIFICATION OF SUBJECT MATTER INV. A46B15/00 A61C17/22 ADD.		
According to International Patent Classification (IPC) or to both national classification and IPC		
B. FIELDS SEARCHED		
Minimum documentation searched (classification system followed by classification symbols) A46B A61C		
Documentation searched other than minimum documentation to the extent that such documents are included in the fields searched		
Electronic data base consulted during the international search (name of data base and, where practicable, search terms used) EPO-Internal, WPI Data		
C. DOCUMENTS CONSIDERED TO BE RELEVANT		
Category*	Citation of document, with indication, where appropriate, of the relevant passages	Relevant to claim No.
Y	US 2011/200959 A1 (RIZOIU IOANA M [US] ET AL) 18 August 2011 (2011-08-18) paragraphs [0043], [0054] - [0056], [0064], [0068], [0069], [0075], [0078], [0080] -----	1,2
Y	DE 10 2007 053985 A1 (OLPP DIETER [DE]) 14 May 2009 (2009-05-14) paragraphs [0002] - [0015], [0027], [0028]; figures 1, 2 -----	1,2
A	DE 296 18 742 U1 (ROWENTA WERKE GMBH [DE]) 16 January 1997 (1997-01-16) the whole document -----	1,2
A	US 2008/102953 A1 (SCHULTZ CHARLES P [US]) 1 May 2008 (2008-05-01) paragraphs [0019], [0035] -----	1,2
-/--		
<input checked="" type="checkbox"/> Further documents are listed in the continuation of Box C. <input checked="" type="checkbox"/> See patent family annex.		
* Special categories of cited documents :		
"A" document defining the general state of the art which is not considered to be of particular relevance "E" earlier application or patent but published on or after the international filing date "L" document which may throw doubts on priority claim(s) or which is cited to establish the publication date of another citation or other special reason (as specified) "O" document referring to an oral disclosure, use, exhibition or other means "P" document published prior to the international filing date but later than the priority date claimed		"T" later document published after the international filing date or priority date and not in conflict with the application but cited to understand the principle or theory underlying the invention "X" document of particular relevance; the claimed invention cannot be considered novel or cannot be considered to involve an inventive step when the document is taken alone "Y" document of particular relevance; the claimed invention cannot be considered to involve an inventive step when the document is combined with one or more other such documents, such combination being obvious to a person skilled in the art "&" document member of the same patent family
Date of the actual completion of the international search	Date of mailing of the international search report	
14 September 2012	20/09/2012	
Name and mailing address of the ISA/ European Patent Office, P.B. 5818 Patentlaan 2 NL - 2280 HV Rijswijk Tel. (+31-70) 340-2040, Fax: (+31-70) 340-3016	Authorized officer  Ardhuin, H��l��ne	

## INTERNATIONAL SEARCH REPORT

International application No  
PCT/IB2012/000711

C(Continuation). DOCUMENTS CONSIDERED TO BE RELEVANT		
Category*	Citation of document, with indication, where appropriate, of the relevant passages	Relevant to claim No.
A	EP 2 218 559 A1 (TRISA HOLDING AG [CH]; EVEREADY BATTERY INC [US]) 18 August 2010 (2010-08-18) paragraphs [0108], [0071], [0072], [0084] - [0088]; claims 1, 10,11,15,16 -----	1,2
A	US 5 673 451 A (MOORE JAMES R [US] ET AL) 7 October 1997 (1997-10-07) column 2, lines 24-36; claims 9, 13, 14 -----	1,2
A	US 6 029 303 A (DEWAN RAMAN N [US]) 29 February 2000 (2000-02-29) column 3, line 56 - column 5, line 11 -----	1,2
A	US 2005/053895 A1 (PINYAYEV ALEKSEY MIKHAILOVICH [US] ET AL) 10 March 2005 (2005-03-10) paragraphs [0032], [0033], [0066], [0076], [0093] -----	1,2
A	US 2007/038272 A1 (LIU WAN-CHI [TW]) 15 February 2007 (2007-02-15) paragraphs [0014], [0018], [0019]; figures 1, 2 -----	1,2

# INTERNATIONAL SEARCH REPORT

Information on patent family members

International application No

PCT/IB2012/000711

Patent document cited in search report	Publication date	Patent family member(s)	Publication date
US 2011200959	A1	18-08-2011	
		AU 2006247036 A1	23-11-2006
		AU 2010202707 A1	15-07-2010
		BR PI0610383 A2	15-06-2010
		CA 2608753 A1	23-11-2006
		EP 1881801 A2	30-01-2008
		IL 187351 A	30-11-2011
		JP 2009506796 A	19-02-2009
		KR 20080015106 A	18-02-2008
		US 2006281042 A1	14-12-2006
		US 2009056044 A1	05-03-2009
		US 2011200959 A1	18-08-2011
		WO 2006125204 A2	23-11-2006
-----			
DE 102007053985	A1	14-05-2009	NONE
-----			
DE 29618742	U1	16-01-1997	NONE
-----			
US 2008102953	A1	01-05-2008	NONE
-----			
EP 2218559	A1	18-08-2010	
		EP 2218559 A1	18-08-2010
		EP 2396150 A1	21-12-2011
		US 2011314677 A1	29-12-2011
		WO 2010091882 A1	19-08-2010
-----			
US 5673451	A	07-10-1997	NONE
-----			
US 6029303	A	29-02-2000	NONE
-----			
US 2005053895	A1	10-03-2005	
		CN 1842303 A	04-10-2006
		CN 1842304 A	04-10-2006
		CN 1842305 A	04-10-2006
		CN 1842306 A	04-10-2006
		CN 1842307 A	04-10-2006
		US 2005050658 A1	10-03-2005
		US 2005053895 A1	10-03-2005
		US 2007298370 A1	27-12-2007
		US 2007298371 A1	27-12-2007
		US 2007298372 A1	27-12-2007
-----			
US 2007038272	A1	15-02-2007	NONE
-----			