

(19) World Intellectual Property Organization
International Bureau



(43) International Publication Date
1 September 2011 (01.09.2011)

(10) International Publication Number
WO 2011/106400 A1

(51) International Patent Classification:
A61B 17/15 (2006.01)

(21) International Application Number:
PCT/US2011/025894

(22) International Filing Date:
23 February 2011 (23.02.2011)

(25) Filing Language: English

(26) Publication Language: English

(30) Priority Data:
61/308,134 25 February 2010 (25.02.2010) US

(71) Applicant (for all designated States except US): **DEPUY PRODUCTS, INC.** [US/US]; 700 Orthopaedic Drive, Warsaw, IN 46581 (US).

(72) Inventors; and

(75) Inventors/Applicants (for US only): **ARAM, Luke, J.** [US/US]; 1311 Oriole Drive, Warsaw, IN 46580 (US). **BUGBEE, William** [US/US]; 700 Orthopaedic Drive, Warsaw, IN 46581 (US). **ENGH, Andrew** [US/US]; 700 Orthopaedic Drive, Warsaw, IN 46581 (US). **MOSKAL,**

Joseph [US/US]; 700 Orthopaedic Drive, Warsaw, IN 46581 (US). **PAGNANO, Mark** [US/US]; 700 Orthopaedic Drive, Warsaw, IN 46581 (US). **SWANK, Michael** [US/US]; 700 Orthopaedic Drive, Warsaw, IN 46581 (US).

(74) Agent: **BAUER, Shawn, D.**; Barnes & Thornburg LLP, 11 South Meridian Street, Indianapolis, IN 46204 (US).

(81) Designated States (unless otherwise indicated, for every kind of national protection available): AE, AG, AL, AM, AO, AT, AU, AZ, BA, BB, BG, BH, BR, BW, BY, BZ, CA, CH, CL, CN, CO, CR, CU, CZ, DE, DK, DM, DO, DZ, EC, EE, EG, ES, FI, GB, GD, GE, GH, GM, GT, HN, HR, HU, ID, IL, IN, IS, JP, KE, KG, KM, KN, KP, KR, KZ, LA, LC, LK, LR, LS, LT, LU, LY, MA, MD, ME, MG, MK, MN, MW, MX, MY, MZ, NA, NG, NI, NO, NZ, OM, PE, PG, PH, PL, PT, RO, RS, RU, SC, SD, SE, SG, SK, SL, SM, ST, SV, SY, TH, TJ, TM, TN, TR, TT, TZ, UA, UG, US, UZ, VC, VN, ZA, ZM, ZW.

(84) Designated States (unless otherwise indicated, for every kind of regional protection available): ARIPO (BW, GH, GM, KE, LR, LS, MW, MZ, NA, SD, SL, SZ, TZ, UG,

[Continued on next page]

(54) Title: CUSTOMIZED PATIENT-SPECIFIC TIBIAL CUTTING BLOCKS

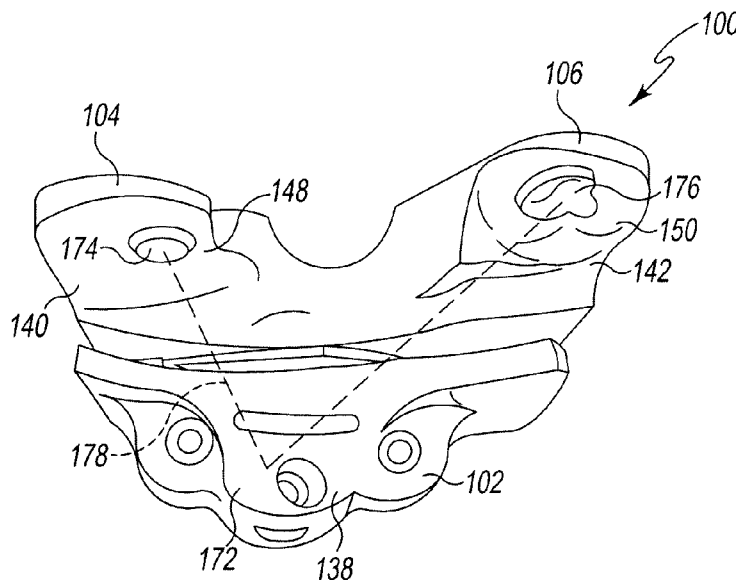

(57) Abstract: A number of orthopaedic surgical instruments are disclosed. A method, apparatus, and system for fabricating such instruments are also disclosed.

Fig. 13

WO 2011/106400 A1

ZM, ZW), Eurasian (AM, AZ, BY, KG, KZ, MD, RU, TJ, TM), European (AL, AT, BE, BG, CH, CY, CZ, DE, DK, EE, ES, FI, FR, GB, GR, HR, HU, IE, IS, IT, LT, LU, LV, MC, MK, MT, NL, NO, PL, PT, RO, RS, SE, SI, SK, SM, TR), OAPI (BF, BJ, CF, CG, CI, CM, GA, GN, GQ, GW, ML, MR, NE, SN, TD, TG).

- *as to applicant's entitlement to apply for and be granted a patent (Rule 4.17(ii))*
- *as to the applicant's entitlement to claim the priority of the earlier application (Rule 4.17(iii))*

Declarations under Rule 4.17:

Published:

- *with international search report (Art. 21(3))*

CUSTOMIZED PATIENT-SPECIFIC TIBIAL CUTTING BLOCKS

[0001] This application claims priority under 35 U.S.C. § 119(e) to U.S. Provisional Patent Application Serial No. 61/308,134, entitled “Customized Patient-Specific Tibial Cutting Blocks,” which was filed on February 25, 2010 by Luke Aram et al., and is continuation-in-part application of co-pending U.S. Utility Patent Application Serial No. 12/240,990 entitled “Customized Patient-Specific Instrumentation for Use In Orthopaedic Surgical Procedures,” which was filed by Luke Aram et al. (Attorney Docket No. 265280-207007, DEP-6047USNP) on September 29, 2008 which claims priority under 35 U.S.C. § 119(e) to U.S. Provisional Patent Application Serial No. 60/976,447 entitled “Method and Apparatus for Fabricating Customized Patient Instrumentation,” which was filed on September 30, 2007 by Dan Auger et al.; U.S. Provisional Patent Application Serial No. 60/976,448 entitled “Adjustable Customized Patient-Specific Orthopaedic Surgical Instrumentation,” which was filed on September 30, 2007 by Luke Aram et al.; U.S. Provisional Patent Application Serial No. 60/976,451 entitled “Customized Patient-Specific Instrumentation For Use In Orthopaedic Surgical Procedures,” which was filed on September 30, 2007 by Jeff Roose et al.; U.S. Provisional Patent Application Serial No. 60/976,444 entitled “Method and Apparatus for Patient-Specific Positioning of Orthopaedic Surgical Instrumentation,” which was filed on September 30, 2007 by Luke Aram et al.; and U.S. Provisional Patent Application Serial No. 60/976,446 entitled “Method and Apparatus for Aligning Customized Patient-Specific Orthopaedic Surgical Instruments,” which was filed on September 30, 2007 by Luke Aram et al., each of these applications is assigned to the same assignee as the present application, and each of which is hereby incorporated by reference.

CROSS-REFERENCE TO RELATED U.S. PATENT APPLICATIONS

[0002] Cross-reference is made to co-pending U.S. Utility Patent Application Serial Nos. 12/240,985; 12/240,990; 12/240,988; 12/240,992; 12/240,994; 12/240,996; 12/240,997; 12/240,998; 12/241,006; 12/241,002; 12/241,001; and 12/240,999. Each of these applications

-2-

was filed on September 29, 2008, and is assigned to the same assignee as the present application. Each of these applications is hereby incorporated by reference.

TECHNICAL FIELD

[0003] The present disclosure relates generally to customized patient-specific orthopaedic surgical instruments and to methods, devices, and systems for fabricating and positioning such instruments.

BACKGROUND

[0004] Joint arthroplasty is a well-known surgical procedure by which a diseased and/or damaged natural joint is replaced by a prosthetic joint. A typical knee prosthesis includes a tibial tray, a femoral component, a polymer insert or bearing positioned between the tibial tray and the femoral component, and, in some cases, a polymer patella button. To facilitate the replacement of the natural joint with the knee prosthesis, orthopaedic surgeons use a variety of orthopaedic surgical instruments such as, for example, cutting blocks, drill guides, milling guides, and other surgical instruments. Typically, the orthopaedic surgical instruments are generic with respect to the patient such that the same orthopaedic surgical instrument may be used on a number of different patients during similar orthopaedic surgical procedures.

SUMMARY

[0005] According to one aspect, a customized patient-specific tibial cutting block includes a body having a bone-facing surface that has a customized patient-specific negative contour configured to receive a portion of an anterior side of a patient's tibia that has a corresponding positive contour. The customized patient-specific negative contour of the body includes a first prominence positioned to contact the portion of the anterior side of the patient's tibia when the portion of the anterior side of the patient's tibia is received in the customized patient-specific negative contour of the body. The customized patient-specific tibial cutting block also includes a first tab extending posteriorly from the body. The first tab has a bone-

facing surface that has a customized patient-specific negative contour configured to receive a first portion of the proximal side of the patient's tibia that has a corresponding positive contour. The customized patient-specific negative contour of the first tab includes a second prominence positioned to contact the first portion of the proximal side of the patient's tibia when the first portion of the proximal side of the patient's tibia is received in the customized patient-specific negative contour of the first tab. The customized patient-specific tibial cutting block further includes a second tab extending posteriorly from the body. The second tab has a bone-facing surface that has a customized patient-specific negative contour configured to receive a second portion of the proximal side of the patient's tibia that has a corresponding positive contour. The customized patient-specific negative contour of the second tab includes a third prominence positioned to contact the second portion of the proximal side of the patient's tibia when the second portion of the proximal side of the patient's tibia is received in the customized patient-specific negative contour of the second tab. The first prominence is located anteriorly and inferiorly to both the second prominence and the third prominence.

[0006] The first tab and the second tab may define an opening therebetween.

[0007] The body of the customized patient-specific tibial cutting block may have a cutting slot defined therein to allow a surgeon to perform a proximal cut on the patient's tibia using the cutting slot.

[0008] The customized patient-specific tibial cutting block may also include a cutting guide coupled to the body. The cutting guide has a cutting slot defined therein. The cutting guide may be formed from a material different from the body and positioned to allow a surgeon to perform a proximal cut on the patient's tibia using the cutting slot.

[0009] The cutting guide may be located superiorly relative to the first prominence.

[0010] The cutting guide may be formed from a metallic material and is overmolded to the body of the customized patient-specific femoral cutting block.

[0011] When viewed from the posterior direction, a V-shaped imaginary line connects the second prominence to the first prominence and the first prominence to the third prominence.

[0012] When viewed from the superior direction, a V-shaped imaginary line connects the second prominence to the first prominence and the first prominence to the third prominence.

[0013] The second and third prominences include protrusions positioned to contact the articular surfaces of the proximal side of the patient's tibia when the proximal side of the patient's tibia is received in the respective customized patient-specific negative contours of the first and second tabs.

[0014] According to another aspect, a customized patient-specific tibial cutting block includes a body having a bone-facing surface that has a customized patient-specific negative contour configured to receive a portion of an anterior side of a patient's tibia that has a corresponding positive contour. The customized patient-specific negative contour of the body includes a first prominence positioned to contact the portion of the anterior side of the patient's tibia when the portion of the anterior side of the patient's tibia is received in the customized patient-specific negative contour of the body. The customized patient-specific tibial cutting block also includes a metallic cutting guide overmolded to the body. The cutting guide has a cutting slot defined therein. The customized patient-specific tibial cutting block also includes a first tab extending posteriorly from the body. The first tab has a bone-facing surface that has a customized patient-specific negative contour configured to receive a first portion of the proximal side of the patient's tibia that has a corresponding positive contour. The customized patient-specific negative contour of the first tab includes a second prominence positioned to contact the first portion of the proximal side of the patient's tibia when the first portion of the proximal side of the patient's tibia is received in the customized patient-specific negative contour of the first tab. The customized patient-specific tibial cutting block further includes a second tab extending posteriorly from the body. The second tab has a bone-facing surface that has a customized patient-specific negative contour configured to receive a second portion of the proximal side of the patient's tibia that has a corresponding positive contour. The customized patient-specific negative contour of the second tab includes a third prominence positioned to contact the second portion of the proximal side of the patient's tibia when the second portion of

the proximal side of the patient's tibia is received in the customized patient-specific negative contour of the second tab. The first prominence is located anteriorly and inferiorly to both the second prominence and the third prominence. The first prominence is also located inferiorly to the cutting slot of the cutting guide.

[0015] The first tab and the second tab may define an opening therebetween.

[0016] When viewed from the posterior direction, a V-shaped imaginary line connects the second prominence to the first prominence and the first prominence to the third prominence.

[0017] When viewed from the superior direction, a V-shaped imaginary line connects the second prominence to the first prominence and the first prominence to the third prominence.

[0018] The second and third prominences include protrusions positioned to contact the articular surfaces of the proximal side of the patient's tibia when the proximal side of the patient's tibia is received in the respective customized patient-specific negative contours of the first and second tabs.

[0019] According to one aspect, a customized patient-specific tibial cutting block includes a body having a bone-facing surface that has a customized patient-specific negative contour configured to receive a portion of an anterior side of a patient's tibia that has a corresponding positive contour. The customized patient-specific negative contour of the body includes a first prominence positioned to contact the portion of the anterior side of the patient's tibia when the portion of the anterior side of the patient's tibia is received in the customized patient-specific negative contour of the body. The customized patient-specific tibial cutting block also includes a first tab extending posteriorly from the body. The first tab has a bone-facing surface that has a customized patient-specific negative contour configured to receive a first portion of the proximal side of the patient's tibia that has a corresponding positive contour. The customized patient-specific negative contour of the first tab includes a second prominence positioned to contact the first portion of the proximal side of the patient's tibia when the first portion of the proximal side of the patient's tibia is received in the customized patient-specific negative contour of the first tab. The customized patient-specific tibial cutting block further

includes a second tab extending posteriorly from the body. The second tab has a bone-facing surface that has a customized patient-specific negative contour configured to receive a second portion of the proximal side of the patient's tibia that has a corresponding positive contour. The customized patient-specific negative contour of the second tab includes a third prominence positioned to contact the second portion of the proximal side of the patient's tibia when the second portion of the proximal side of the patient's tibia is received in the customized patient-specific negative contour of the second tab. When viewed from the posterior direction, a V-shaped imaginary line connects the second prominence to the first prominence and the first prominence to the third prominence. When viewed from the superior direction, a V-shaped imaginary line connects the second prominence to the first prominence and the first prominence to the third prominence.

[0020] The first tab and the second tab may define an opening therebetween.

[0021] The body of the customized patient-specific tibial cutting block may have a cutting slot defined therein to allow a surgeon to perform a proximal cut on the patient's tibia using the cutting slot.

[0022] The customized patient-specific tibial cutting block may also include a cutting guide coupled to the body. The cutting guide has a cutting slot defined therein. The cutting guide may be formed from a material different from the body and positioned to allow a surgeon to perform a proximal cut on the patient's tibia using the cutting slot.

[0023] The cutting guide may be located superiorly relative to the first prominence.

[0024] The cutting guide may be formed from a metallic material and is overmolded to the body of the customized patient-specific femoral cutting block.

[0025] The second and third prominences include protrusions positioned to contact the articular surfaces of the proximal side of the patient's tibia when the proximal side of the patient's tibia is received in the respective customized patient-specific negative contours of the first and second tabs.

BRIEF DESCRIPTION OF THE DRAWINGS

- [0026] The detailed description particularly refers to the following figures, in which:
- [0027] FIG. 1 is a simplified flow diagram of an algorithm for designing and fabricating a customized patient-specific orthopaedic surgical instrument;
- [0028] FIG. 2 is a simplified flow diagram of a method for generating a model of a patient-specific orthopaedic instrument;
- [0029] FIG. 3 is a simplified flow diagram of a method for scaling a reference contour;
- [0030] FIGS. 4-6 are three-dimensional model's of a patient's tibia;
- [0031] FIG. 7-9 are three-dimensional models of a patient's femur;
- [0032] FIG. 10 is an anterior elevation an embodiment of a customized patient-specific orthopaedic surgical instrument;
- [0033] FIG. 11 is a top plan view of the customized patient-specific orthopaedic surgical instrument of FIG. 10;
- [0034] FIG. 12 is side elevation view of the customized patient-specific orthopaedic surgical instrument of FIG. 10;
- [0035] FIG. 13 shows the customized patient-specific orthopaedic surgical instrument of FIG. 10, as viewed from the posterior direction; and
- [0036] FIG. 14 shows the customized patient-specific orthopaedic surgical instrument of FIG. 10 secured to the tibia of a patient, as viewed from the superior direction.

DETAILED DESCRIPTION OF THE DRAWINGS

[0037] While the concepts of the present disclosure are susceptible to various modifications and alternative forms, specific exemplary embodiments thereof have been shown by way of example in the drawings and will herein be described in detail. It should be understood, however, that there is no intent to limit the concepts of the present disclosure to the particular forms disclosed, but on the contrary, the intention is to cover all modifications,

equivalents, and alternatives falling within the spirit and scope of the invention as defined by the appended claims.

[0038] Terms representing anatomical references, such as anterior, posterior, medial, lateral, superior, inferior, etcetera, may be used throughout this disclosure in reference to the orthopaedic implants and instruments described herein, along with a patient's natural anatomy. Such terms have well-understood meanings in both the study of anatomy and the field of orthopaedics. Use of such anatomical reference terms in the specification and claims is intended to be consistent with their well-understood meanings unless noted otherwise.

[0039] Referring to FIG. 1, an algorithm 10 for fabricating a customized patient-specific orthopaedic surgical instrument is illustrated. What is meant herein by the term "customized patient-specific orthopaedic surgical instrument" is a surgical tool for use by a surgeon in performing an orthopaedic surgical procedure that is intended, and configured, for use on a particular patient. As such, it should be appreciated that, as used herein, the term "customized patient-specific orthopaedic surgical instrument" is distinct from standard, non-patient specific orthopaedic surgical instruments that are intended for use on a variety of different patients. Additionally, it should be appreciated that, as used herein, the term "customized patient-specific orthopaedic surgical instrument" is distinct from orthopaedic prostheses, whether patient-specific or generic, which are surgically implanted in the body of the patient. Rather, customized patient-specific orthopaedic surgical instruments are used by an orthopaedic surgeon to assist in the implantation of orthopaedic prostheses.

[0040] In some embodiments, the customized patient-specific orthopaedic surgical instrument may be customized to the particular patient based on the location at which the instrument is to be coupled to one or more bones of the patient, such as the femur and/or tibia. For example, in some embodiments, the customized patient-specific orthopaedic surgical instrument may include a bone-contacting or facing surface having a negative contour that matches or substantially matches the contour of a portion of the relevant bone of the patient. As such, the customized patient-specific orthopaedic surgical instrument is configured to be

coupled to the bone of a patient in a unique location and position with respect to the patient's bone. That is, the negative contour of the bone-contacting surface is configured to receive the matching contour surface of the portion of the patient's bone. As such, the orthopaedic surgeon's guesswork and/or intra-operative decision-making with respect to the placement of the orthopaedic surgical instrument are reduced. For example, the orthopaedic surgeon may not be required to locate landmarks of the patient's bone to facilitate the placement of the orthopaedic surgical instrument, which typically requires some amount of estimation on part of the surgeon. Rather, the orthopaedic surgeon may simply couple the customized patient-specific orthopaedic surgical instrument on the bone or bones of the patient in the unique location. When so coupled, the cutting plane, drilling holes, milling holes, and/or other guides are defined in the proper location relative to the bone and intended orthopaedic prosthesis. The customized patient-specific orthopaedic surgical instrument may be embodied as any type of orthopaedic surgical instrument such as, for example, a bone-cutting block, a drilling guide, a milling guide, or other type of orthopaedic surgical instrument configured to be coupled to a bone of a patient.

[0041] As shown in FIG. 1, the algorithm 10 includes process steps 12 and 14, in which an orthopaedic surgeon performs pre-operative planning of the orthopaedic surgical procedure to be performed on a patient. The process steps 12 and 14 may be performed in any order or contemporaneously with each other. In process step 12, a number of medical images of the relevant bony anatomy or joint of the patient are generated. To do so, the orthopaedic surgeon or other healthcare provider may operate an imaging system to generate the medical images. The medical images may be embodied as any number and type of medical images capable of being used to generate a three-dimensional rendered model of the patient's bony anatomy or relevant joint. For example, the medical images may be embodied as any number of computed tomography (CT) images, magnetic resonance imaging (MRI) images, or other three-dimensional medical images. Additionally or alternatively, as discussed in more detail below in regard to process step 18, the medical images may be embodied as a number of X-ray images or

other two-dimensional images from which a three-dimensional rendered model of the patient's relevant bony anatomy may be generated. Additionally, in some embodiments, the medical image may be enhanced with a contrast agent designed to highlight the cartilage surface of the patient's knee joint.

[0042] In process step 14, the orthopaedic surgeon may determine any additional pre-operative constraint data. The constraint data may be based on the orthopaedic surgeon's preferences, preferences of the patient, anatomical aspects of the patient, guidelines established by the healthcare facility, or the like. For example, the constraint data may include the orthopaedic surgeon's preference for a metal-on-metal interface, amount of inclination for implantation, the thickness of the bone to resect, size range of the orthopaedic implant, and/or the like. In some embodiments, the orthopaedic surgeon's preferences are saved as a surgeon's profile, which may be used as a default constraint values for further surgical plans.

[0043] In process step 16, the medical images and the constraint data, if any, are transmitted or otherwise provided to an orthopaedic surgical instrument vendor or manufacturer. The medical images and the constraint data may be transmitted to the vendor via electronic means such as a network or the like. After the vendor has received the medical images and the constraint data, the vendor processes the images in step 18. The orthopaedic surgical instrument vendor or manufacturer process the medical images to facilitate the determination of the bone cutting planes, implant sizing, and fabrication of the customized patient-specific orthopaedic surgical instrument as discussed in more detail below. For example, in process step 20 the vendor may convert or otherwise generate three-dimensional images from the medical images. For example, in embodiments wherein the medical images are embodied as a number of two-dimensional images, the vendor may use a suitable computer algorithm to generate one or more three-dimensional images from the number of two-dimensional images. Additionally, in some embodiments, the medical images may be generated based on an established standard such as the Digital Imaging and Communications in Medicine (DICOM) standard. In such embodiments, an edge-detection, thresholding,

watershead, or shape-matching algorithm may be used to convert or reconstruct images to a format acceptable in a computer aided design application or other image processing application. Further, in some embodiments, an algorithm may be used to account for tissue such as cartilage not discernable in the generated medical images. In such embodiments, any three-dimensional model of the patient-specific instrument (see, e.g., process step 26 below) may be modified according to such algorithm to increase the fit and function of the instrument.

[0044] In process step 22, the vendor may process the medical images, and/or the converted/reconstructed images from process step 20, to determine a number of aspects related to the bony anatomy of the patient such as the anatomical axis of the patient's bones, the mechanical axis of the patient's bone, other axes and various landmarks, and/or other aspects of the patient's bony anatomy. To do so, the vendor may use any suitable algorithm to process the images.

[0045] In process step 24, the cutting planes of the patient's bone are determined. The planned cutting planes are determined based on the type, size, and position of the orthopaedic prosthesis to be used during the orthopaedic surgical procedure, on the process images such as specific landmarks identified in the images, and on the constraint data supplied by the orthopaedic surgeon in process steps 14 and 16. The type and/or size of the orthopaedic prosthesis may be determined based on the patient's anatomy and the constraint data. For example, the constraint data may dictate the type, make, model, size, or other characteristic of the orthopaedic prosthesis. The selection of the orthopaedic prosthesis may also be modified based on the medical images such that an orthopaedic prosthesis that is usable with the bony anatomy of the patient and that matches the constraint data or preferences of the orthopaedic surgeon is selected.

[0046] In addition to the type and size of the orthopaedic prosthesis, the planned location and position of the orthopaedic prosthesis relative to the patient's bony anatomy is determined. To do so, a digital template of the selected orthopaedic prosthesis may be overlaid onto one or more of the processed medical images. The vendor may use any suitable algorithm

to determine a recommended location and orientation of the orthopaedic prosthesis (i.e., the digital template) with respect to the patient's bone based on the processed medical images (e.g., landmarks of the patient's bone defined in the images) and/or the constraint data. Additionally, any one or more other aspects of the patient's bony anatomy may be used to determine the proper positioning of the digital template.

[0047] In some embodiments, the digital template along with surgical alignment parameters may be presented to the orthopaedic surgeon for approval. The approval document may include the implant's rotation with respect to bony landmarks such as the femoral epicondyle, posterior condyles, sulcus groove (Whiteside's line), and the mechanical axis as defined by the hip, knee, and/or ankle centers.

[0048] The planned cutting planes for the patient's bone(s) may then be determined based on the determined size, location, and orientation of the orthopaedic prosthesis. In addition, other aspects of the patient's bony anatomy, as determined in process step 22, may be used to determine or adjust the planned cutting planes. For example, the determined mechanical axis, landmarks, and/or other determined aspects of the relevant bones of the patient may be used to determine the planned cutting planes.

[0049] In process step 26, a model of the customized patient-specific orthopaedic surgical instrument is generated. In some embodiments, the model is embodied as a three-dimensional rendering of the customized patient-specific orthopaedic surgical instrument. In other embodiments, the model may be embodied as a mock-up or fast prototype of the customized patient-specific orthopaedic surgical instrument. The particular type of orthopaedic surgical instrument to be modeled and fabricated may be determined based on the orthopaedic surgical procedure to be performed, the constraint data, and/or the type of orthopaedic prosthesis to be implanted in the patient. As such, the customized patient-specific orthopaedic surgical instrument may be embodied as any type of orthopaedic surgical instrument for use in the performance of an orthopaedic surgical procedure. For example, the orthopaedic surgical

instrument may be embodied as a bone-cutting block, a drilling guide, a milling guide, and/or any other type of orthopaedic surgical tool or instrument.

[0050] The particular shape of the customized patient-specific orthopaedic surgical instrument is determined based on the planned location of the orthopaedic surgical instrument relative to the patient's bony anatomy. The location of the customized patient-specific orthopaedic surgical instrument with respect to the patient's bony anatomy is determined based on the type and determined location of the orthopaedic prosthesis to be used during the orthopaedic surgical procedure. That is, the planned location of the customized patient-specific orthopaedic surgical instrument relative to the patient's bony anatomy may be selected based on, in part, the planned cutting planes of the patient's bone(s) as determined in step 24. For example, in embodiments wherein the customized patient-specific orthopaedic surgical instrument is embodied as a bone-cutting block, the location of the orthopaedic surgical instrument is selected such that the cutting guide of the bone-cutting block matches one or more of the planned cutting planes determined in process step 24. Additionally, the planned location of the orthopaedic surgical instrument may be based on the identified landmarks of the patient's bone identified in process step 22.

[0051] In some embodiments, the particular shape or configuration of the customized patient-specific orthopaedic surgical instrument may be determined based on the planned location of the instrument relative to the patient's bony anatomy. That is, the customized patient-specific orthopaedic surgical instrument may include a bone-contacting surface having a negative contour that matches the contour of a portion of the bony anatomy of the patient such that the orthopaedic surgical instrument may be coupled to the bony anatomy of the patient in a unique location, which corresponds to the pre-planned location for the instrument. When the orthopaedic surgical instrument is coupled to the patient's bony anatomy in the unique location, one or more guides (e.g., cutting or drilling guide) of the orthopaedic surgical instrument may be aligned to one or more of the bone cutting plane(s) as discussed above.

[0052] One illustrative embodiment of a method 40 for generating a model, such as a computer model, of a patient-specific orthopaedic instrument is illustrated in FIGS. 2 through 9. The method 40 begins with a step 42 in which a cartilage thickness value is determined. The cartilage thickness value is indicative of the average thickness of the cartilage of the patient's bone. As such, in one embodiment, the cartilage thickness value is equal to the average thickness of cartilage for an individual having similar characteristics as the patient. For example, the cartilage thickness value may be equal to the average thickness value of individuals of the same gender as the patient, the same age as the patient, having the same activity level of the patient, and/or the like. In other embodiments, the cartilage thickness value is determined based on one or more medical images of the patient's bone, such as those images transmitted in process step 16.

[0053] In step 44, a reference contour of the patient's relevant bone is determined. The reference contour is based on the surface contour of a three-dimensional model of the patient's relevant bone, such as the three-dimensional model generated in step 20. Initially the reference contour is identical to a region (i.e. the region of interest such as the distal end of the patient's femur or the proximal end of the patient's tibia) of the patient's bone. That is, in some embodiments, the reference contour is juxtaposed on the surface contour of the region of the patient's bone.

[0054] Subsequently, in step 46, the reference contour is scaled to compensate for the cartilage thickness value determined in step 42. To do so, in one embodiment, the scale of the reference contour is increased based on the cartilage thickness value. For example, the scale of the reference contour may be increased by an amount equal to or determined from the cartilage thickness value. However, in other embodiments, the reference contour may be scaled using other techniques designed to scale the reference contour to a size at which the reference contour is compensated for the thickness of the cartilage on the patient's bone.

[0055] For example, in one particular embodiment, the reference contour is scaled by increasing the distance between a fixed reference point and a point lying on, and defining in

part, the reference contour. To do so, in one embodiment, a method 60 for scaling a reference contour as illustrated in FIG. 3 may be used. The method 60 begins with step 62 in which a medial/lateral line segment is established on the three-dimensional model of the patient's relevant bone. The medial/lateral line segment is defined or otherwise selected so as to extend from a point lying on the medial surface of the patient's bone to a point lying on lateral surface of the patient's bone. The medial surface point and the lateral surface point may be selected so as to define the substantially maximum local medial/lateral width of the patient's bone in some embodiments.

[0056] In step 64, an anterior/posterior line segment is established on the three-dimensional model of the patient's relevant bone. The anterior/posterior line segment is defined or otherwise selected so as to extend from a point lying on the anterior surface of the patient's bone to a point lying on posterior surface of the patient's bone. The anterior surface point and the posterior surface point may be selected so as to define the substantially maximum local anterior/posterior width of the patient's bone in some embodiments.

[0057] The reference point from which the reference contour will be scaled is defined in step 66 as the intersection point of the medial/lateral line segment and anterior/posterior line segment. As such, it should be appreciated that the medial surface point, the lateral surface point, the anterior surface point, and the posterior surface point lie on the same plane. After the reference point is initially established in step 66, the reference point is moved or otherwise translated toward an end of the patient's bone. For example, in embodiments wherein the patient's bone is embodied as a femur, the reference point is moved inferiorly toward the distal end of the patient's femur. Conversely, in embodiments when the patient's bone is embodied as a tibia, the reference point is moved superiorly toward the proximal end of the patient's tibia. In one embodiment, the reference point is moved a distance equal to about half the length of the anterior/posterior line segment as determined in step 64. However, in other embodiments, the reference point may be moved other distances sufficient to compensate the reference contour for thickness of the cartilage present on the patient's bone.

[0058] Once the location of the reference point has been determined in step 68, the distance between the reference point and each point lying on, and defining in part, the reference contour is increased in step 70. To do so, in one particular embodiment, each point of the reference contour is moved a distance away from the reference point based on a percentage value of the original distance defined between the reference point and the particular point on the reference contour. For example, in one embodiment, each point lying on, and defining in part, the reference contour is moved away from the reference point in by a distance equal to a percentage value of the original distance between the reference point and the particular point. In one embodiment, the percentage value is in the range of about 5 percent to about thirty percent. In one particular embodiment, the percentage value is about ten percent.

[0059] Referring now to FIGS. 4-9, in another embodiment, the reference contour is scaled by manually selecting a local "high" point on the surface contour of the three-dimensional image of the patient's bone. For example, in embodiments wherein the relevant patient's bone is embodied as a tibia as illustrated in FIGS. 4-6, the reference point 90 is initially located on the tibial plateau high point of the tibial model 92. Either side of the tibial plateau may be used. Once the reference point 90 is initially established on the tibial plateau high point, the reference point 90 is translated to the approximate center of the plateau as illustrated in FIG. 5 such that the Z-axis defining the reference point is parallel to the mechanical axis of the tibial model 92. Subsequently, as illustrated in FIG. 6, the reference point is moved in the distal direction by a predetermined amount. In one particular embodiment, the reference point is moved in the distal direction by about 20 millimeters, but other distances may be used in other embodiments. For example, the distance over which the reference point is moved may be based on the cartilage thickness value in some embodiments.

[0060] Conversely, in embodiments wherein the relevant patient's bone is embodied as a femur as illustrated in FIGS. 7-9, the reference point 90 is initially located on the most distal point of the distal end of the femoral model 94. Either condyle of the femoral model 94 may be used in various embodiments. Once the reference point 90 is initially established on the most

distal point, the reference point 90 is translated to the approximate center of the distal end of the femoral model 94 as illustrated in FIG. 8 such that the Z-axis defining the reference point 90 is parallel to the mechanical axis of the femoral model 92. The anterior-posterior width 96 of the distal end of the femoral model 94 is also determined. Subsequently, as illustrated in FIG. 9, the reference point is moved or otherwise translated in the proximal or superior direction by a distance 98. In one particular embodiment, the reference point is moved in the distal or superior direction by a distance 98 equal to about half the distance 96. As such, it should be appreciated that one of a number of different techniques may be used to define the location of the reference point based on, for example, the type of bone.

[0061] Referring now back to FIG. 2, once the reference contour has been scaled in step 46, the medial/lateral sides of the reference contour are adjusted in step 48. To do so, in one embodiment, the distance between the reference point and each point lying on, and defining in part, the medial side and lateral side of the reference contour is decreased. For example, in some embodiments, the distance between the reference point and the points on the medial and lateral sides of the scaled reference contour are decreased to the original distance between such points. As such, it should be appreciated that the reference contour is offset or otherwise enlarged with respect to the anterior side of the patient's bone and substantially matches or is otherwise not scaled with respect to the medial and lateral sides of the patient's bone.

[0062] The reference contour may also be adjusted in step 48 for areas of the patient's bone having a reduced thickness of cartilage. Such areas of reduced cartilage thickness may be determined based on the existence of bone-on-bone contact as identified in a medical image, simulation, or the like. Additionally, information indicative of such areas may be provided by the orthopaedic surgeon based on his/her expertise. If one or more areas of reduced cartilage thickness are identified, the reference contour corresponding to such areas of the patient's bone is reduced (i.e., scaled back or down).

[0063] Additionally, in some embodiments, one or more osteophytes on the patient's bone may be identified; and the reference contour may be compensated for such presence of the

osteophytes. By compensating for such osteophytes, the reference contour more closely matches the surface contour of the patient's bone. Further, in some embodiments, a distal end (in embodiments wherein the patient's bone is embodied as a tibia) or a proximal end (in embodiments wherein the patient's bone is embodied as a femur) of the reference contour may be adjusted to increase the conformity of the reference contour to the surface contour of the bone. For example, in embodiments wherein the patient's bone is a femur, the superior end of the scaled reference contour may be reduced or otherwise moved closer to the surface contour of the patient's femur in the region located superiorly to a cartilage demarcation line defined on the patient's femur. Conversely, in embodiments wherein the patient's bone is embodied as a tibia, an inferior end of the scaled reference contour may be reduced or otherwise moved closer to the surface contour of the patient's tibia in the region located inferiorly to a cartilage demarcation line of the patient's tibia. As such, it should be appreciated that the scaled reference contour is initially enlarged to compensate for the thickness of the patient's cartilage on the patient's bone. Portions of the scaled reference contour are then reduced or otherwise moved back to original positions and/or toward the reference point in those areas where cartilage is lacking, reduced, or otherwise not present.

[0064] Once the reference contour has been scaled and adjusted in steps 46 and 48, the position of the cutting guide is defined in step 50. In particular, the position of the cutting guide is defined based on an angle defined between a mechanical axis of the patient's femur and a mechanical axis of the patient's tibia. The angle may be determined by establishing a line segment or ray originating from the proximal end of the patient's femur to the distal end of the patient's femur and defining a second line segment or ray extending from the patient's ankle through the proximal end of the patient's tibia. The angle defined by these two line segments/rays is equal to the angle defined between the mechanical axis of the patient's femur and tibia. The position of the bone cutting guide is then determined based on the angle between the mechanical axes of the patient's femur and tibia. It should be appreciated that the position of the cutting guide defines the position and orientation of the cutting plane of the customized

patient-specific cutting block. Subsequently, in step 52, a negative contour of the customized patient-specific cutting block is defined based on the scaled and adjusted reference contour and the angle defined between the mechanical axis of the femur and tibia.

[0065] Referring back to FIG. 1, after the model of the customized patient-specific orthopaedic surgical instrument has been generated in process step 26, the model is validated in process step 28. The model may be validated by, for example, analyzing the rendered model while coupled to the three-dimensional model of the patient's anatomy to verify the correlation of cutting guides and planes, drilling guides and planned drill points, and/or the like. Additionally, the model may be validated by transmitting or otherwise providing the model generated in step 26 to the orthopaedic surgeon for review. For example, in embodiments wherein the model is a three-dimensional rendered model, the model along with the three-dimensional images of the patient's relevant bone(s) may be transmitted to the surgeon for review. In embodiments wherein the model is a physical prototype, the model may be shipped to the orthopaedic surgeon for validation.

[0066] After the model has been validated in process step 28, the customized patient-specific orthopaedic surgical instrument is fabricated in process step 30. The customized patient-specific orthopaedic surgical instrument may be fabricated using any suitable fabrication device and method. Additionally, the customized patient-specific orthopaedic instrument may be formed from any suitable material such as a metallic material, a plastic material, or combination thereof depending on, for example, the intended use of the instrument. The fabricated customized patient-specific orthopaedic instrument is subsequently shipped or otherwise provided to the orthopaedic surgeon. The surgeon performs the orthopaedic surgical procedure in process step 32 using the customized patient-specific orthopaedic surgical instrument. As discussed above, because the orthopaedic surgeon does not need to determine the proper location of the orthopaedic surgical instrument intra-operatively, which typically requires some amount of estimation on part of the surgeon, the guesswork and/or intra-operative decision-making on part of the orthopaedic surgeon is reduced.

[0067] Referring now to FIGS. 10-12, in one embodiment, the customized patient-specific orthopaedic surgical instrument may be embodied as a tibial cutting block 100. The cutting block 100 is configured to be coupled to a tibia of a patient. The cutting block 100 includes a body 102 configured to be coupled to the anterior side of the patient's tibia and two arms or tabs 104, 106 which extend posteriorly away from the body 102. The tabs 104, 106 are configured to wrap around a proximal end of the tibia as discussed in more detail below. The cutting block 100 may be formed from any suitable material. For example, the cutting block 100 may be formed from a plastic or resin material. In one particular embodiment, the cutting block 100 is formed from Vero resin using a rapid prototype fabrication process. However, the cutting block 100 may be formed from other materials in other embodiments. For example, in another particular embodiment, the cutting block 100 is formed from a polyimide thermoplastic resin, such as a Ultem resin, which is commercially available from Saudi Basic Industries Corporation Innovative Plastics of Riyadh, Saudi Arabia.

[0068] The body 102 includes a bone-contacting or bone-facing surface 112 and an outer surface 114 opposite the bone-facing surface 112. The outer surface 114 includes a number of guide holes or passageways 116 defined therethrough. A guide pin bushing 118 is received in each guide hole 116. The guide pin bushings 118 include an internal passageway 120 sized to receive a respective guide pin to secure the block 100 to the patient's tibia. As shown in FIG. 12, the guide passageways 116 extends from the outer surface 114 to the bone-facing surface 112 and is counterbored on the bone-facing surface 112. That is, the passageway 116 has an opening 122 on the bone-facing surface 112 having a diameter greater than the diameter of an opening 124 on the outer surface 114.

[0069] The cutting guide 100 includes a cutting guide 130 secured to the body 102. In one particular embodiment, the cutting guide 130 is overmolded to the body 102. The cutting guide 130 includes a cutting guide slot 132. The cutting guide 130 may be formed from the same material as the body 102 or from a different material. In one particular embodiment, the cutting guide 130 is formed from a metallic material such as stainless steel. The body 102 also

includes a window or opening 134 to allow a surgeon to visualize the positioning of the block 100 on the patient's tibia by viewing portions of the tibia through the opening 134. In the illustrative embodiment, the window 134 is embodied as a notch 136 defined on a superior end surface 137 of the body 102 of the cutting guide 100. However, in other embodiments, the cutting block 100 may include windows or openings formed in the body 102 having other shapes and sizes.

[0070] The bone-facing surface 112 of the body 102 includes a negative contour 138 configured to receive a portion of the anterior side of the patient's tibia having a corresponding contour and a portion of the medial side of the patient's tibia. The customized patient-specific negative contour 138 of the bone-contacting surface 112 allows the positioning of the cutting block 100 on the patient's tibia in a unique pre-determined location and orientation. In the exemplary embodiment described herein, the negative contour 138 is selected such that cutting block 100 is configured to be coupled to the patient's tibia on an anterior-medial side, as opposed to solely on the anterior surface of the tibia. For example, as illustrated in FIG. 11, when the cutting block 100 is secured to a patient's tibia, an angle (α) is defined between a vertically-extending, bisecting plane 162 of the body 102 of the block 100 and a bisecting sagittal plane 164 of the patient's tibia (i.e., the A/P plane 164). The magnitude of the angle (α) may be selected based on, for example, the gender or age of the patient. In one particular embodiment, the angle (α) is in the range of about 10° to about 30°. In another particular embodiment, the angle is about 20°.

[0071] The tabs 104, 106 include a bone-contacting or bone-facing surface 140, 142, respectively, and an outer surface 144, 146, respectively, opposite the bone-facing surface 140, 142. The bone-facing surface 140 of the tab 104 includes a negative contour 148 configured to receive a portion of the proximal side of the patient's tibia having a respective corresponding contour. Similarly, the bone-facing surface 142 of the tab 106 includes a negative contour 150 configured to receive a portion of the proximal side of the patient's tibia having a respective corresponding contour.

[0072] As can be seen in FIG. 13, the negative contour 138 of the body 102 includes an anterior prominence 172. The anterior prominence 172 abuts the anterior bone surface of the proximal tibia when the tibial cutting block 100 is properly positioned on the proximal tibia. The negative contours of each of the tabs 104, 106 likewise has a prominence formed thereon. In particular, the negative contour 148 of the tab 104 has a protrusion 174 that is positioned to contact a portion of the articular surface of the proximal side of the patient's tibia when the cutting block 100 is secured thereto (see FIG. 14). Similarly, the negative contour 150 of the tab 106 has a protrusion 176 that is positioned to contact a portion of the articular surface of the proximal side of the patient's tibia when the cutting block 100 is secured thereto (see FIG. 14).

[0073] As can be seen in FIGS. 13 and 14, the anterior prominence 172 is located anteriorly and inferiorly relative to the prominences 174, 176. As such, when viewed from the posterior direction such as shown in FIG. 13, a V-shaped imaginary line 178 connects the prominence 174 of the tab 104 to the anterior prominence 172, and the anterior prominence 172 to the prominence 176 of the tab 106. Likewise, when viewed from the superior direction, a V-shaped imaginary line 180 connects the prominence 174 of the tab 104 to the anterior prominence 172, and the anterior prominence 172 to the prominence 176 of the tab 106. Such a configuration using the three prominences 172, 174, 176 enhances the stability of the cutting block 100.

[0074] It should be appreciated that the prominences 174, 176 may be designed to sit on top of the articular cartilage of the tibia. In addition, the prominences 174, 176 may be customized designed to sit within pre-operatively determined voids in the cartilage in the manner described in co-pending, commonly-owned U.S. Patent Application Serial No. XX/XXX,XXX, entitled "Customized Patient-Specific Cutting Blocks Having Locating Features and Method of Making the Same" by Bryan Rose et al., which was filed concurrently herewith and is incorporated herein by reference.

[0075] As discussed above, the arms or tabs 104, 106 extend posteriorly from the body 102 to define a U-shaped opening 105 therebetween. The tabs 104, 106 may extend from the

body 102 the same distance or a different distance. For example, as shown in FIG. 11, the tab 104 extends from the body 102 a distance 152 and the tab 106 extends from the body 102 by a distance 154, which is greater than the distance 152. Each of the tabs 104, 106 includes a respective elongated opening or window 160 defined therethrough. Similar to the window 134 described above, the windows 160 allow a surgeon to visualize the positioning of the block 100 on the patient's tibia by viewing portions of the proximal end tibia through the opening 160 134.

[0076] In some embodiments, the negative contours 138, 148, 150 of the bone-contacting surfaces 112, 140, 142 of the cutting block 1400 may or may not match the corresponding contour surface of the patient's bone. That is, as discussed above, the negative contours 138, 148, 150 may be scaled or otherwise resized (e.g., enlarged) to compensate for the patient's cartilage or lack thereof.

[0077] In use, the tibial cutting block 100 is coupled to the proximal end of the patient's tibia. Again, because the bone-contacting surfaces 112, 140, 142 of the cutting block 100 include the negative contours 138, 148, 150 the block 100 may be coupled to the patient's tibia in a pre-planned, unique position. When so coupled, the tabs 104, 106 wrap around the proximal end of the patient's tibia and the lips 108, 110 of the tabs 104, 106 wrap around the posterior side of the patient's tibia. Additionally, when the block 100 is coupled to the patient's tibia, a portion of the anterior side of the tibia is received in the negative contour 138 of the body 102 and a portion of the proximal side of the patient's tibia is received in the negative contours 148, 150 of the tabs 104, 106.

[0078] While the disclosure has been illustrated and described in detail in the drawings and foregoing description, such an illustration and description is to be considered as exemplary and not restrictive in character, it being understood that only illustrative embodiments have been shown and described and that all changes and modifications that come within the spirit of the disclosure are desired to be protected.

[0079] There are a plurality of advantages of the present disclosure arising from the various features of the apparatus, system, and method described herein. It will be noted that alternative embodiments of the apparatus, system, and method of the present disclosure may not include all of the features described yet still benefit from at least some of the advantages of such features. Those of ordinary skill in the art may readily devise their own implementations of the apparatus, system, and method that incorporate one or more of the features of the present invention and fall within the spirit and scope of the present disclosure as defined by the appended claims.

WHAT IS CLAIMED IS

1. A customized patient-specific tibial cutting block, comprising:

a body having a bone-facing surface that has a customized patient-specific negative contour configured to receive a portion of an anterior side of a patient's tibia that has a corresponding positive contour, the customized patient-specific negative contour of the body comprises a first prominence positioned to contact the portion of the anterior side of the patient's tibia when the portion of the anterior side of the patient's tibia is received in the customized patient-specific negative contour of the body,

a first tab extending posteriorly from the body, the first tab having a bone-facing surface that has a customized patient-specific negative contour configured to receive a first portion of the proximal side of the patient's tibia that has a corresponding positive contour, the customized patient-specific negative contour of the first tab comprises a second prominence positioned to contact the first portion of the proximal side of the patient's tibia when the first portion of the proximal side of the patient's tibia is received in the customized patient-specific negative contour of the first tab, and

a second tab extending posteriorly from the body, the second tab having a bone-facing surface that has a customized patient-specific negative contour configured to receive a second portion of the proximal side of the patient's tibia that has a corresponding positive contour, the customized patient-specific negative contour of the second tab comprises a third prominence positioned to contact the second portion of the proximal side of the patient's tibia when the second portion of the proximal side of the patient's tibia is received in the customized patient-specific negative contour of the second tab, wherein the first prominence is located anteriorly and inferiorly to both the second prominence and the third prominence.

2. The customized patient-specific tibial cutting block of claim 1, wherein the first tab and the second tab define an opening therebetween.

3. The customized patient-specific tibial cutting block of claim 1, wherein the body has a cutting slot defined therein, the cutting slot being positioned to allow a surgeon to perform a proximal cut on the patient's tibia using the cutting slot.

4. The customized patient-specific tibial cutting block of claim 1, further comprising a cutting guide coupled to the body, wherein:

the cutting guide has a cutting slot defined therein, and

the cutting guide is formed from a material different from the body and being positioned to allow a surgeon to perform a proximal cut on the patient's tibia using the cutting slot.

5. The customized patient-specific tibial cutting block of claim 4, wherein the cutting guide is formed from a metallic material and is overmolded to the body of the customized patient-specific femoral cutting block.

6. The customized patient-specific tibial cutting block of claim 1, wherein when viewed from the posterior direction, a V-shaped imaginary line connects the second prominence to the first prominence and the first prominence to the third prominence.

7. The customized patient-specific tibial cutting block of claim 1, wherein when viewed from the superior direction, a V-shaped imaginary line connects the second prominence to the first prominence and the first prominence to the third prominence.

8. The customized patient-specific tibial cutting block of claim 1, wherein the second and third prominences comprises protrusions positioned to contact the articular surfaces of the proximal side of the patient's tibia when the proximal side of the patient's tibia

is received in the respective customized patient-specific negative contours of the first and second tabs.

9. The customized patient-specific tibial cutting block of claim 1, further comprising a cutting guide coupled to the body, wherein:

the cutting guide has a cutting slot defined therein, and

the cutting guide is located superiorly relative to the first prominence.

10. A customized patient-specific tibial cutting block, comprising:

a body having a bone-facing surface that has a customized patient-specific negative contour configured to receive a portion of an anterior side of a patient's tibia that has a corresponding positive contour, the customized patient-specific negative contour of the body comprises a first prominence positioned to contact the portion of the anterior side of the patient's tibia when the portion of the anterior side of the patient's tibia is received in the customized patient-specific negative contour of the body,

a metallic cutting guide overmolded to the body, the cutting guide having a cutting slot defined therein,

a first tab extending posteriorly from the body, the first tab having a bone-facing surface that has a customized patient-specific negative contour configured to receive a first portion of the proximal side of the patient's tibia that has a corresponding positive contour, the customized patient-specific negative contour of the first tab comprises a second prominence positioned to contact the first portion of the proximal side of the patient's tibia when the first portion of the proximal side of the patient's tibia is received in the customized patient-specific negative contour of the first tab, and

a second tab extending posteriorly from the body, the second tab having a bone-facing surface that has a customized patient-specific negative contour configured to receive a second portion of the proximal side of the patient's tibia that has a corresponding positive

contour, the customized patient-specific negative contour of the second tab comprises a third prominence positioned to contact the second portion of the proximal side of the patient's tibia when the second portion of the proximal side of the patient's tibia is received in the customized patient-specific negative contour of the second tab, wherein the first prominence is located (i) anteriorly and inferiorly to both the second prominence and the third prominence, and (ii) inferiorly to the cutting slot of the cutting guide.

11. The customized patient-specific tibial cutting block of claim 10, wherein the first tab and the second tab define an opening therebetween.

12. The customized patient-specific tibial cutting block of claim 10, wherein when viewed from the posterior direction, a V-shaped imaginary line connects the second prominence to the first prominence and the first prominence to the third prominence.

13. The customized patient-specific tibial cutting block of claim 10, wherein when viewed from the superior direction, a V-shaped imaginary line connects the second prominence to the first prominence and the first prominence to the third prominence.

14. The customized patient-specific tibial cutting block of claim 10, wherein the second and third prominences comprises protrusions positioned to contact the articular surfaces of the proximal side of the patient's tibia when the proximal side of the patient's tibia is received in the respective customized patient-specific negative contours of the first and second tabs.

15. A customized patient-specific tibial cutting block, comprising:
a body having a bone-facing surface that has a customized patient-specific negative contour configured to receive a portion of an anterior side of a patient's tibia that has a

corresponding positive contour, the customized patient-specific negative contour of the body comprises a first prominence positioned to contact the portion of the anterior side of the patient's tibia when the portion of the anterior side of the patient's tibia is received in the customized patient-specific negative contour of the body,

a first tab extending posteriorly from the body, the first tab having a bone-facing surface that has a customized patient-specific negative contour configured to receive a first portion of the proximal side of the patient's tibia that has a corresponding positive contour, the customized patient-specific negative contour of the first tab comprises a second prominence positioned to contact the first portion of the proximal side of the patient's tibia when the first portion of the proximal side of the patient's tibia is received in the customized patient-specific negative contour of the first tab, and

a second tab extending posteriorly from the body, the second tab having a bone-facing surface that has a customized patient-specific negative contour configured to receive a second portion of the proximal side of the patient's tibia that has a corresponding positive contour, the customized patient-specific negative contour of the second tab comprises a third prominence positioned to contact the second portion of the proximal side of the patient's tibia when the second portion of the proximal side of the patient's tibia is received in the customized patient-specific negative contour of the second tab,

wherein (i) when viewed from the posterior direction, a first V-shaped imaginary line connects the second prominence to the first prominence and the first prominence to the third prominence, and (ii) when viewed from the superior direction, a V-shaped imaginary line connects the second prominence to the first prominence and the first prominence to the third prominence.

16. The customized patient-specific tibial cutting block of claim 15, wherein the first tab and the second tab define an opening therebetween.

-30-

17. The customized patient-specific tibial cutting block of claim 16, wherein the body has a cutting slot defined therein, the cutting slot being positioned to allow a surgeon to perform a proximal cut on the patient's tibia using the cutting slot.

18. The customized patient-specific tibial cutting block of claim 15, further comprising a cutting guide coupled to the body, wherein:

the cutting guide has a cutting slot defined therein, and

the cutting guide is formed from a material different from the body and being positioned to allow a surgeon to perform a proximal cut on the patient's tibia using the cutting slot.

19. The customized patient-specific tibial cutting block of claim 18, wherein the cutting guide is formed from a metallic material and is overmolded to the body of the customized patient-specific femoral cutting block.

20. The customized patient-specific tibial cutting block of claim 15, wherein the second and third prominences comprises protrusions positioned to contact the articular surfaces of the proximal side of the patient's tibia when the proximal side of the patient's tibia is received in the respective customized patient-specific negative contours of the first and second tabs.

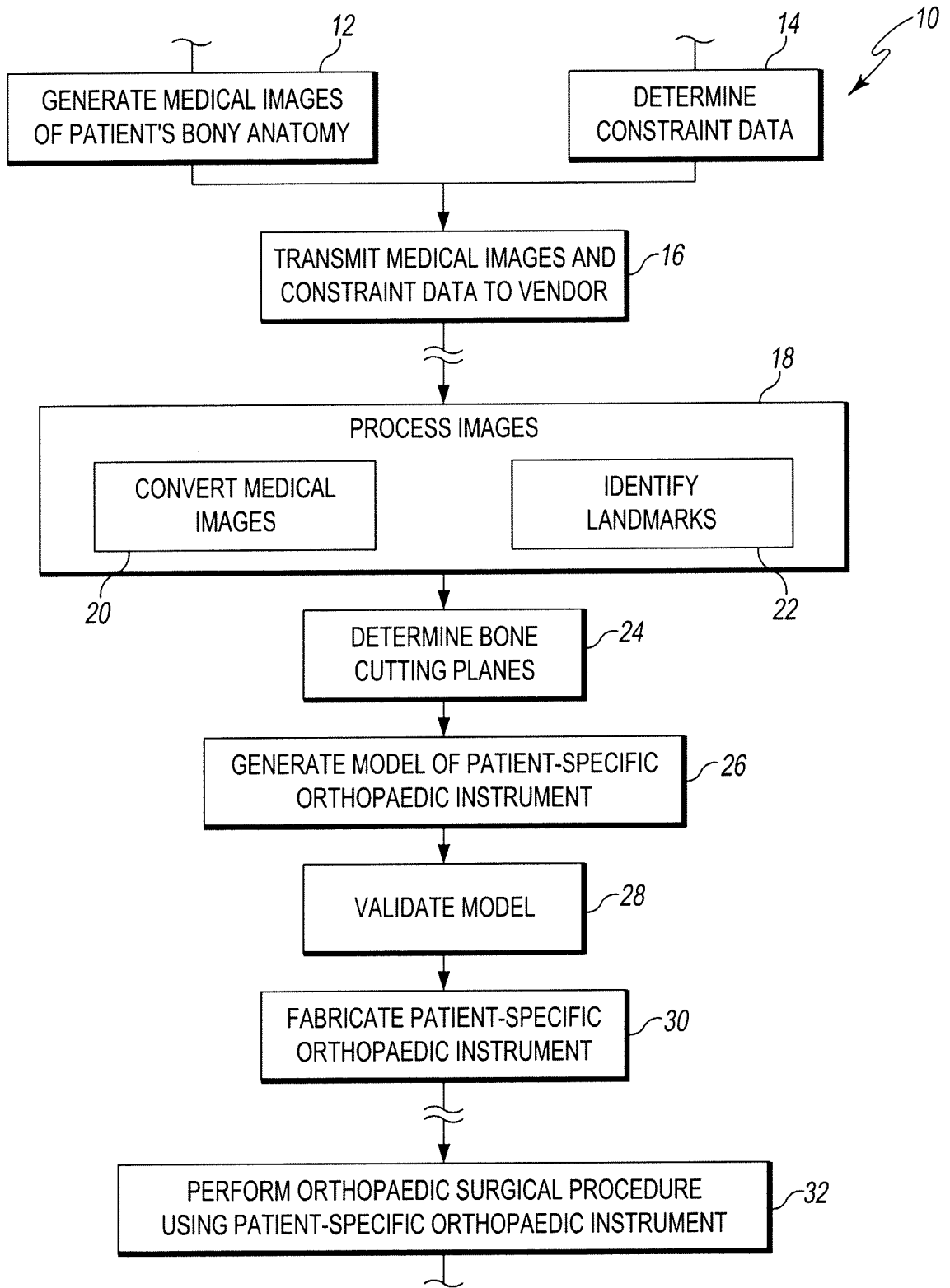

Fig. 1

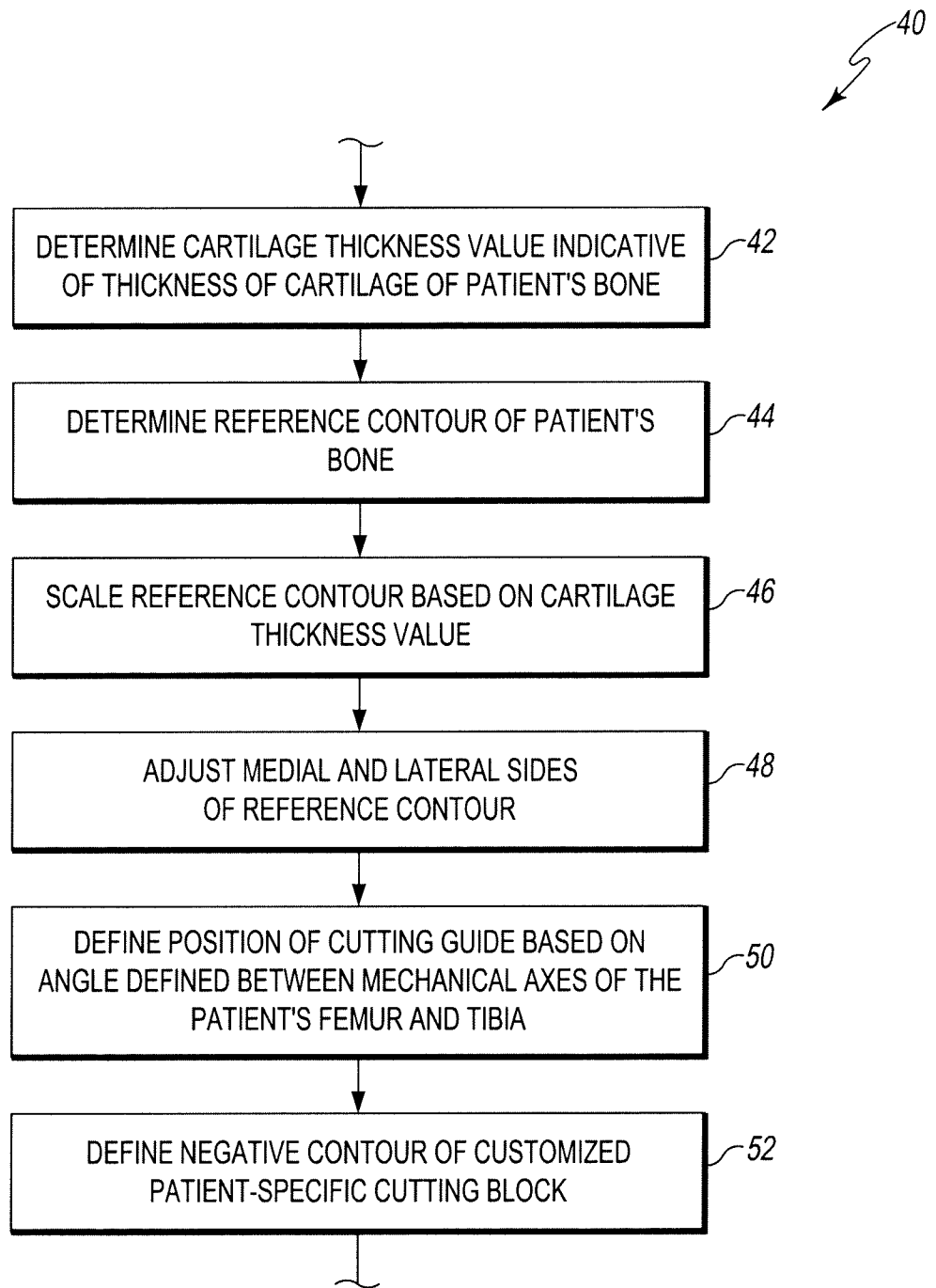

Fig. 2

60

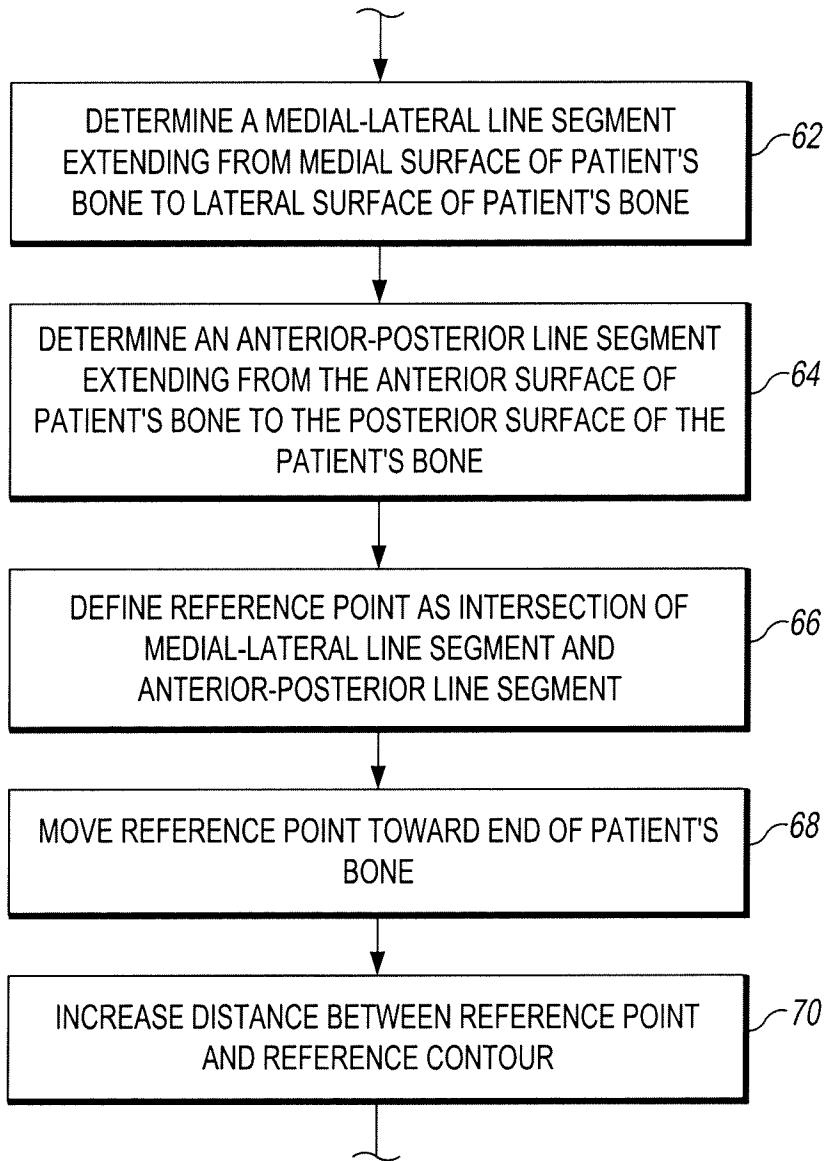

Fig. 3

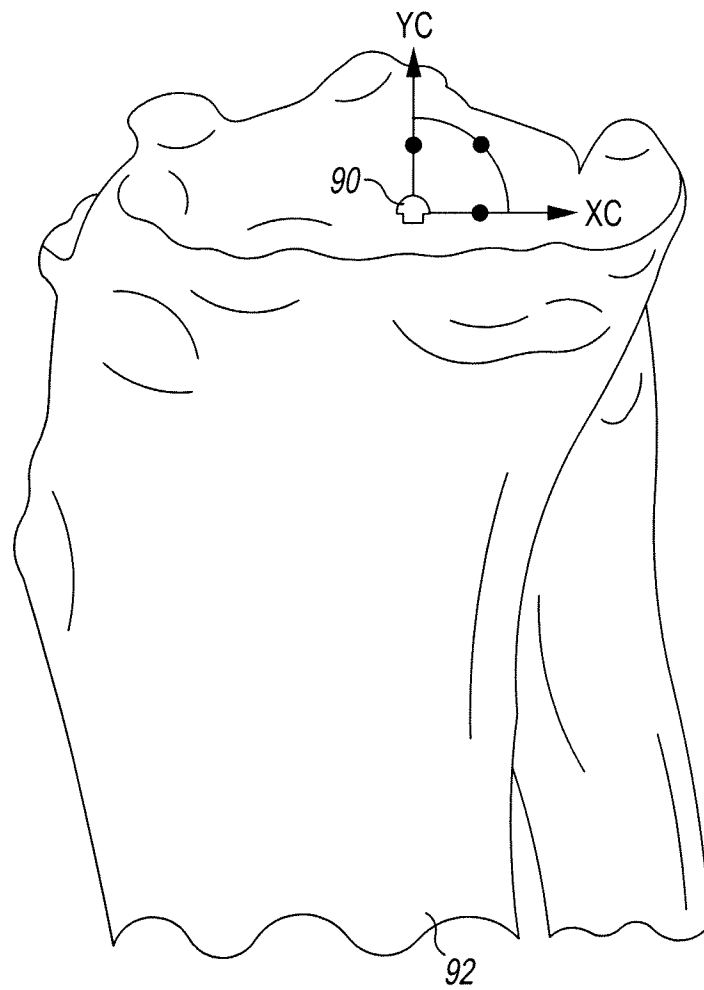

Fig. 4

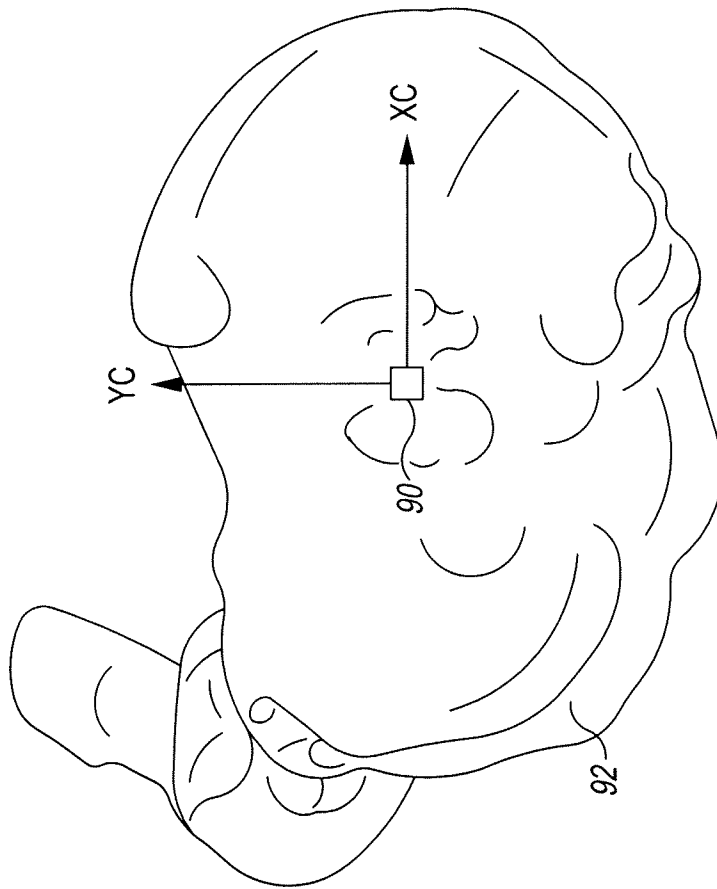

Fig. 5

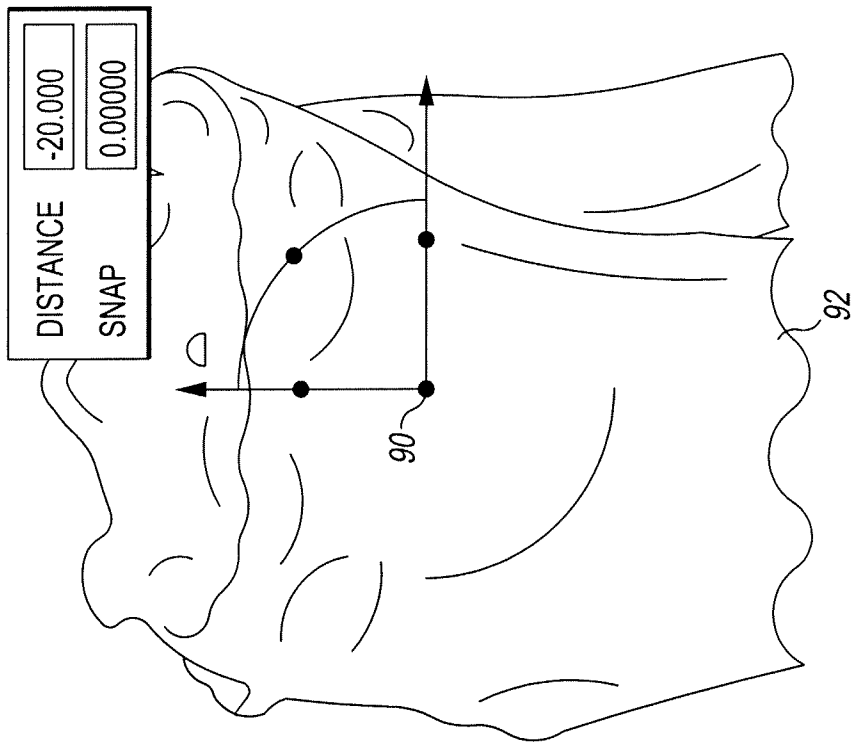

Fig. 6

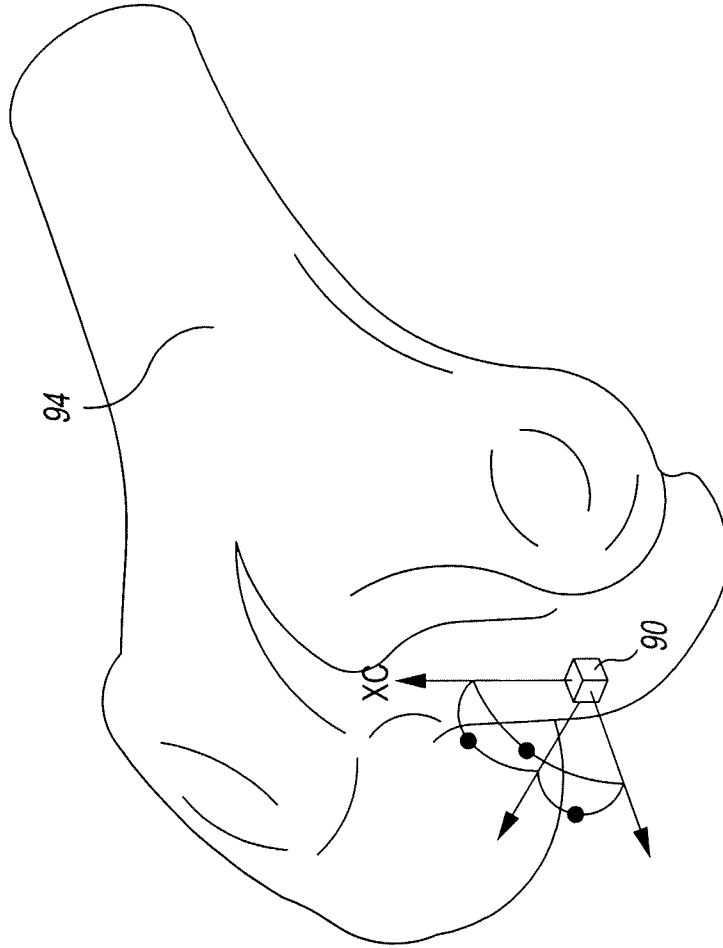

Fig. 7

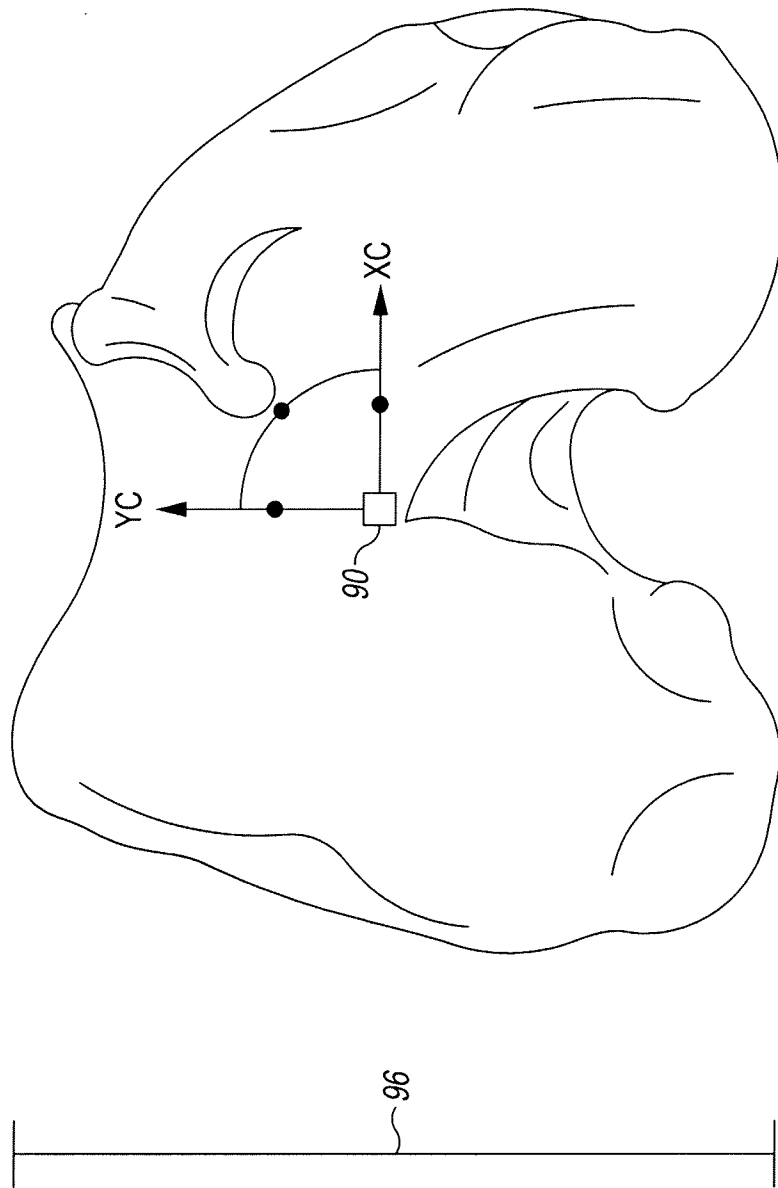

Fig. 8

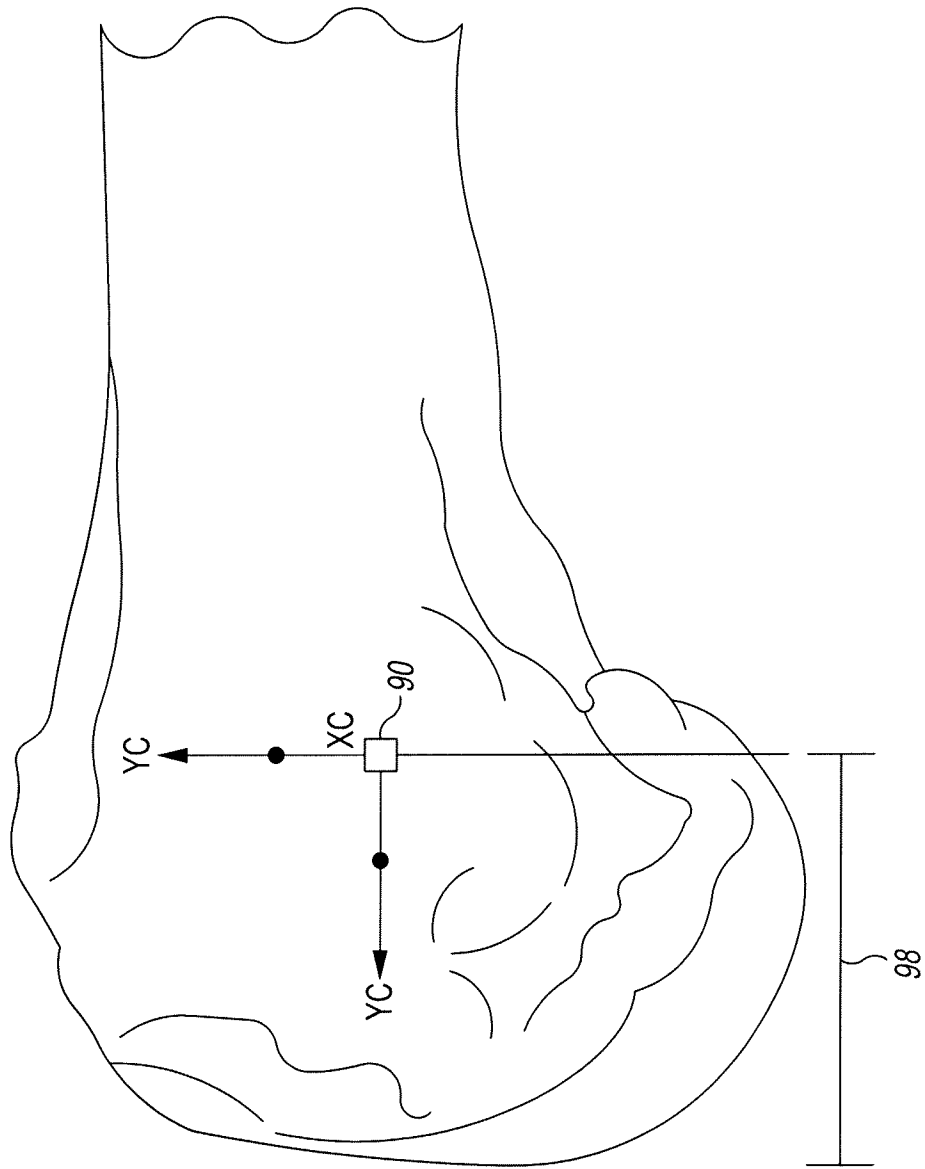

Fig. 9

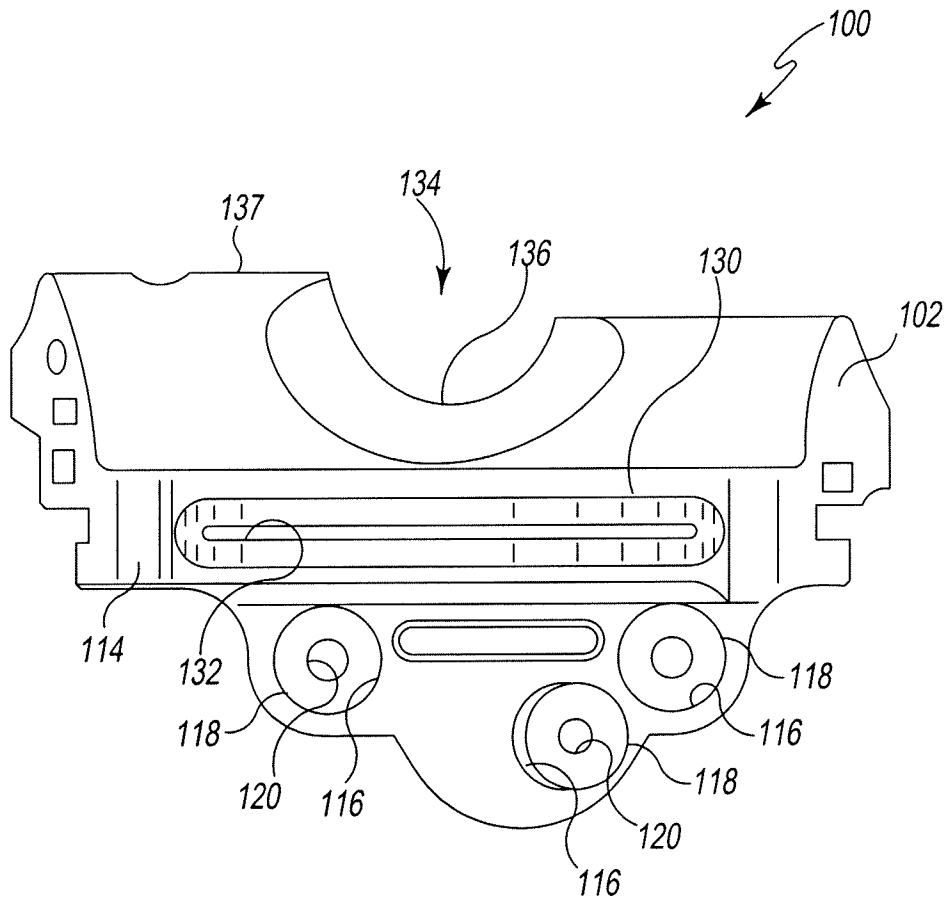

Fig. 10

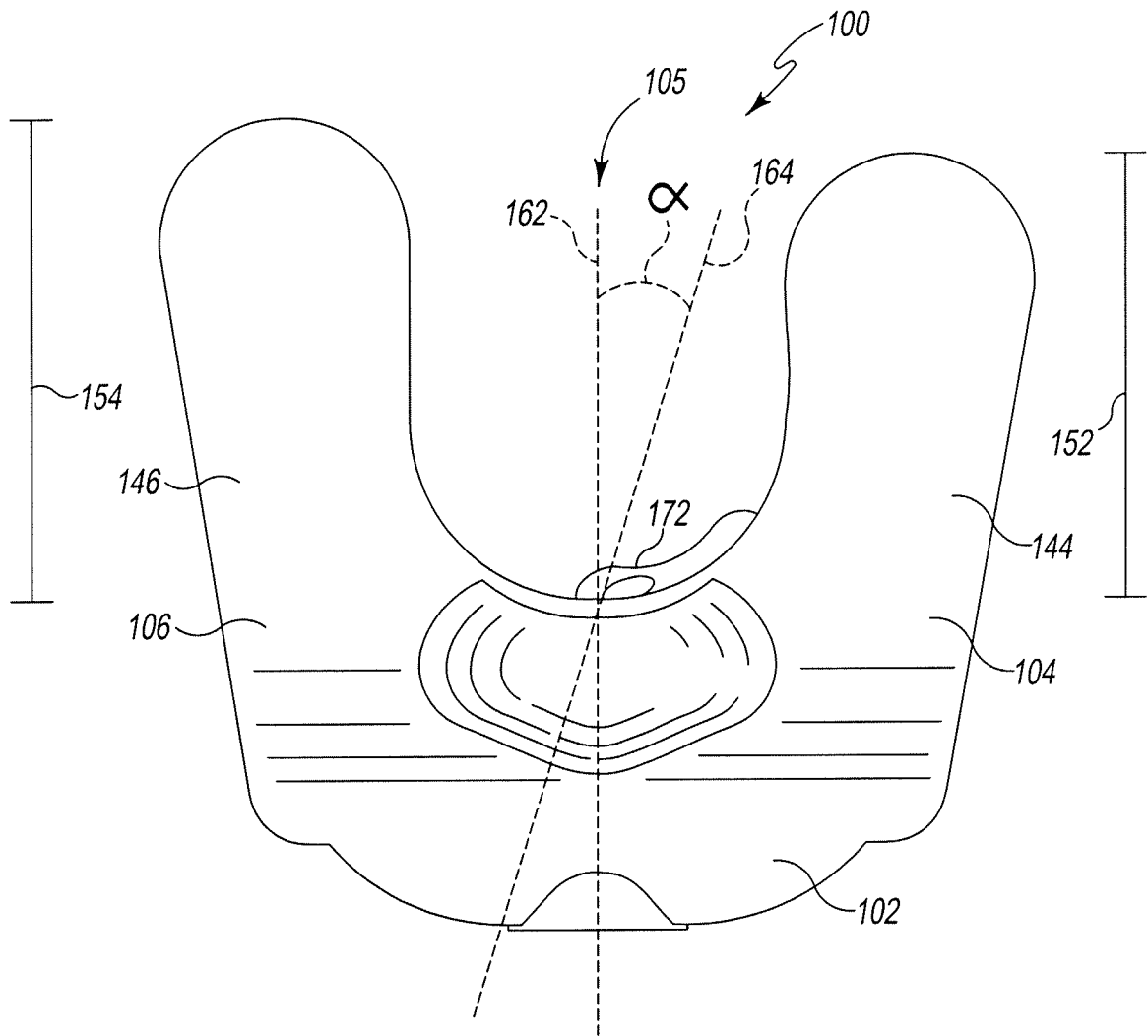

Fig. 11

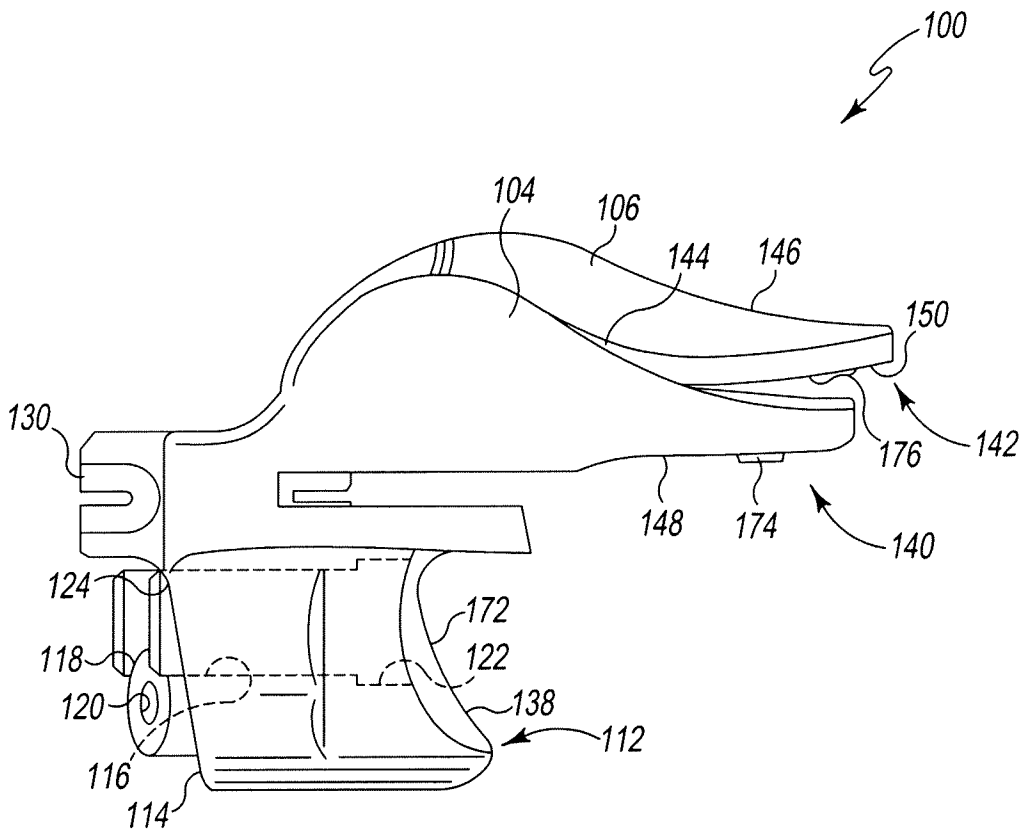

Fig. 12

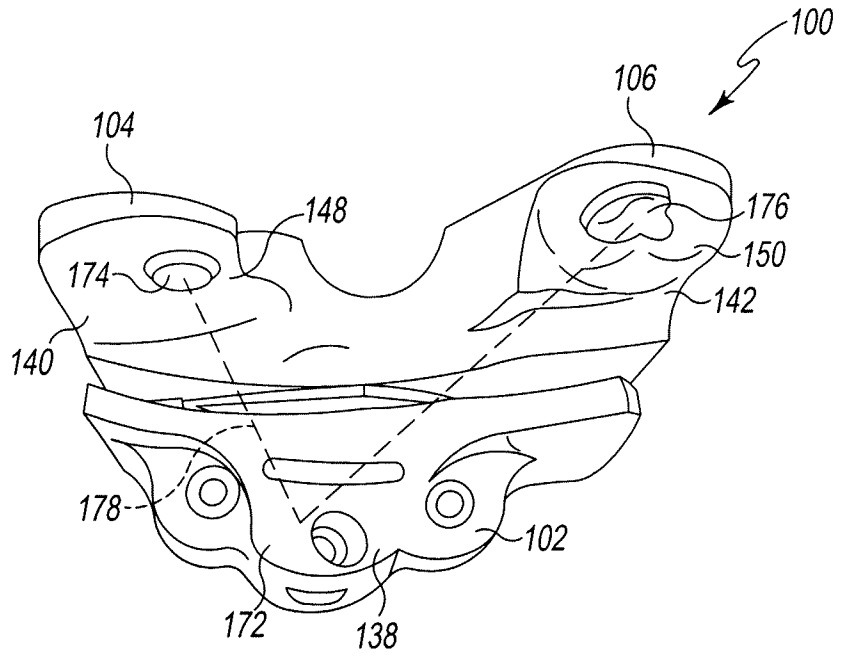

Fig. 13

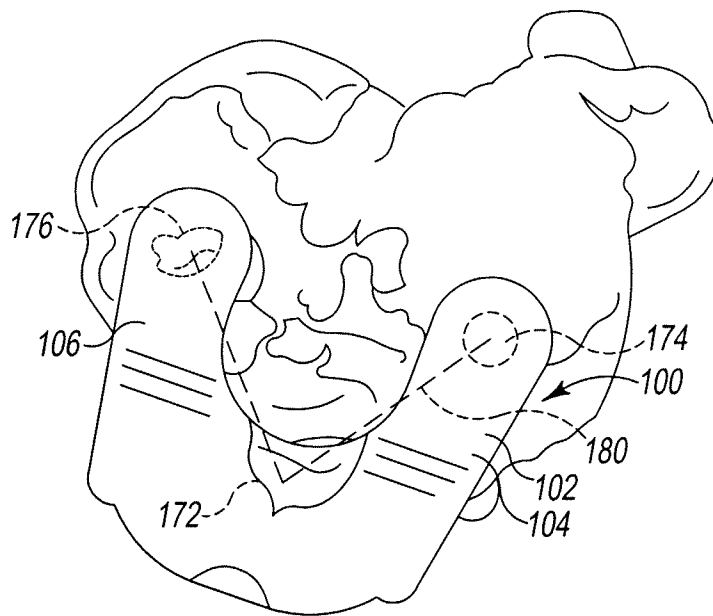

Fig. 14

INTERNATIONAL SEARCH REPORT

International application No.

PCT/US2011/025894

A. CLASSIFICATION OF SUBJECT MATTER IPC(8) - A61B 17/15 (2011.01) USPC - 606/88 According to International Patent Classification (IPC) or to both national classification and IPC												
B. FIELDS SEARCHED												
Minimum documentation searched (classification system followed by classification symbols) IPC(8) - A61B 17/00, 17/15, 17/58 (2011.01) USPC - 606/79, 87, 88, 89												
Documentation searched other than minimum documentation to the extent that such documents are included in the fields searched												
Electronic data base consulted during the international search (name of data base and, where practicable, search terms used) Orbit												
C. DOCUMENTS CONSIDERED TO BE RELEVANT												
Category*	Citation of document, with indication, where appropriate, of the relevant passages	Relevant to claim No.										
Y	US 2009/0088753 A1 (ARAM et al) 02 April 2009 (02.04.2009) entire document	1-20										
Y	WO 2009/001083 A1 (DODDS et al) 31 December 2008 (31.12.2008) entire document	1-20										
A	US 2009/0088761 A1 (ROOSE et al) 02 April 2009 (02.04.2009) entire document	1-20										
<input type="checkbox"/> Further documents are listed in the continuation of Box C. <input type="checkbox"/>												
<p>* Special categories of cited documents:</p> <table border="0"> <tr> <td>"A" document defining the general state of the art which is not considered to be of particular relevance</td> <td>"T" later document published after the international filing date or priority date and not in conflict with the application but cited to understand the principle or theory underlying the invention</td> </tr> <tr> <td>"E" earlier application or patent but published on or after the international filing date</td> <td>"X" document of particular relevance; the claimed invention cannot be considered novel or cannot be considered to involve an inventive step when the document is taken alone</td> </tr> <tr> <td>"L" document which may throw doubts on priority claim(s) or which is cited to establish the publication date of another citation or other special reason (as specified)</td> <td>"Y" document of particular relevance; the claimed invention cannot be considered to involve an inventive step when the document is combined with one or more other such documents, such combination being obvious to a person skilled in the art</td> </tr> <tr> <td>"O" document referring to an oral disclosure, use, exhibition or other means</td> <td>"&" document member of the same patent family</td> </tr> <tr> <td>"P" document published prior to the international filing date but later than the priority date claimed</td> <td></td> </tr> </table>			"A" document defining the general state of the art which is not considered to be of particular relevance	"T" later document published after the international filing date or priority date and not in conflict with the application but cited to understand the principle or theory underlying the invention	"E" earlier application or patent but published on or after the international filing date	"X" document of particular relevance; the claimed invention cannot be considered novel or cannot be considered to involve an inventive step when the document is taken alone	"L" document which may throw doubts on priority claim(s) or which is cited to establish the publication date of another citation or other special reason (as specified)	"Y" document of particular relevance; the claimed invention cannot be considered to involve an inventive step when the document is combined with one or more other such documents, such combination being obvious to a person skilled in the art	"O" document referring to an oral disclosure, use, exhibition or other means	"&" document member of the same patent family	"P" document published prior to the international filing date but later than the priority date claimed	
"A" document defining the general state of the art which is not considered to be of particular relevance	"T" later document published after the international filing date or priority date and not in conflict with the application but cited to understand the principle or theory underlying the invention											
"E" earlier application or patent but published on or after the international filing date	"X" document of particular relevance; the claimed invention cannot be considered novel or cannot be considered to involve an inventive step when the document is taken alone											
"L" document which may throw doubts on priority claim(s) or which is cited to establish the publication date of another citation or other special reason (as specified)	"Y" document of particular relevance; the claimed invention cannot be considered to involve an inventive step when the document is combined with one or more other such documents, such combination being obvious to a person skilled in the art											
"O" document referring to an oral disclosure, use, exhibition or other means	"&" document member of the same patent family											
"P" document published prior to the international filing date but later than the priority date claimed												
Date of the actual completion of the international search 05 April 2011		Date of mailing of the international search report 25 APR 2011										
Name and mailing address of the ISA/US Mail Stop PCT, Attn: ISA/US, Commissioner for Patents P.O. Box 1450, Alexandria, Virginia 22313-1450 Facsimile No. 571-273-3201		Authorized officer: Blaine R. Copenheaver PCT Helpdesk: 571-272-4300 PCT OSP: 571-272-7774										