

(No Model.)

2 Sheets—Sheet 1.

R. A. YOUNG.

SEED OR CORN PLANTER.

No. 366,752.

Patented July 19, 1887.

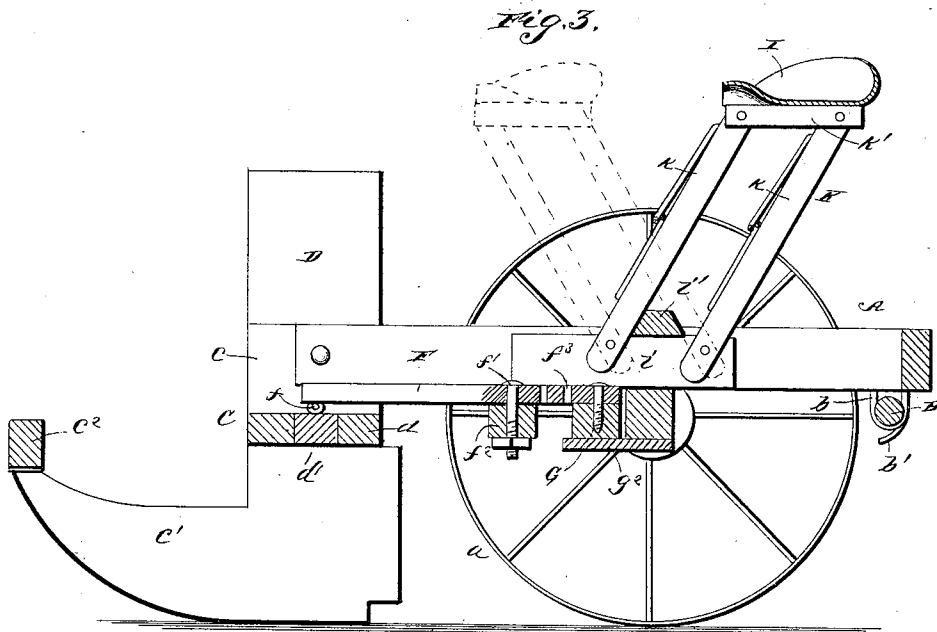
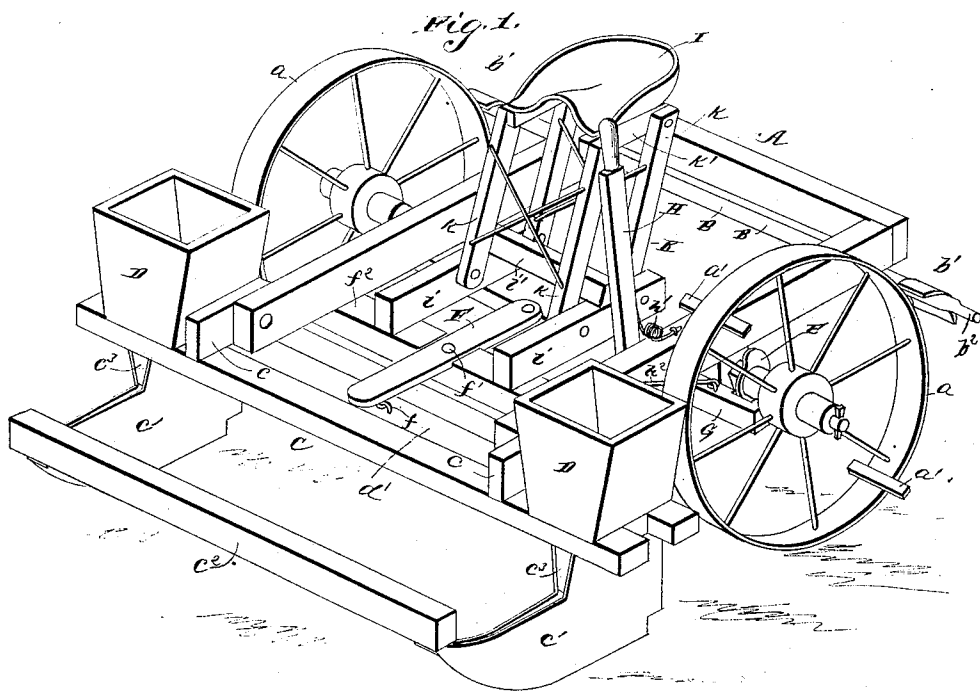

Witnesses

*C. B. Taylor*

*E. Y. Siggers*

Inventor

*Robert A. Young*

By his Attorneys,

*C. A. Howdlea*

R. A. YOUNG.  
SEED OR CORN PLANTER.

No. 366,752.

Patented July 19, 1887.

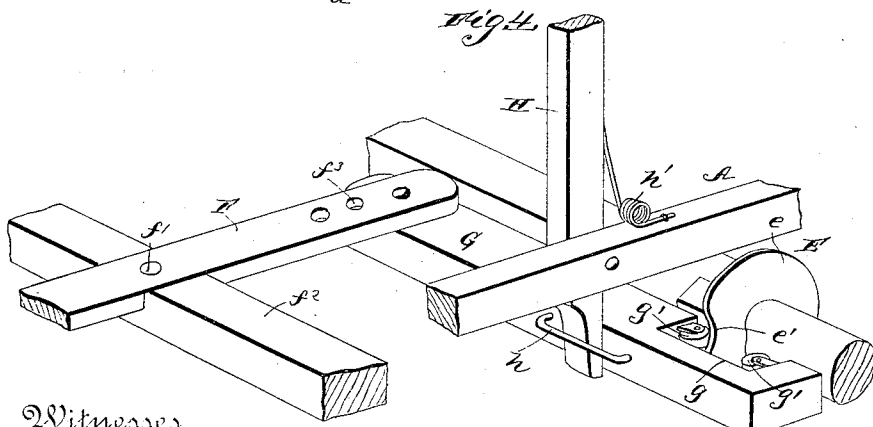
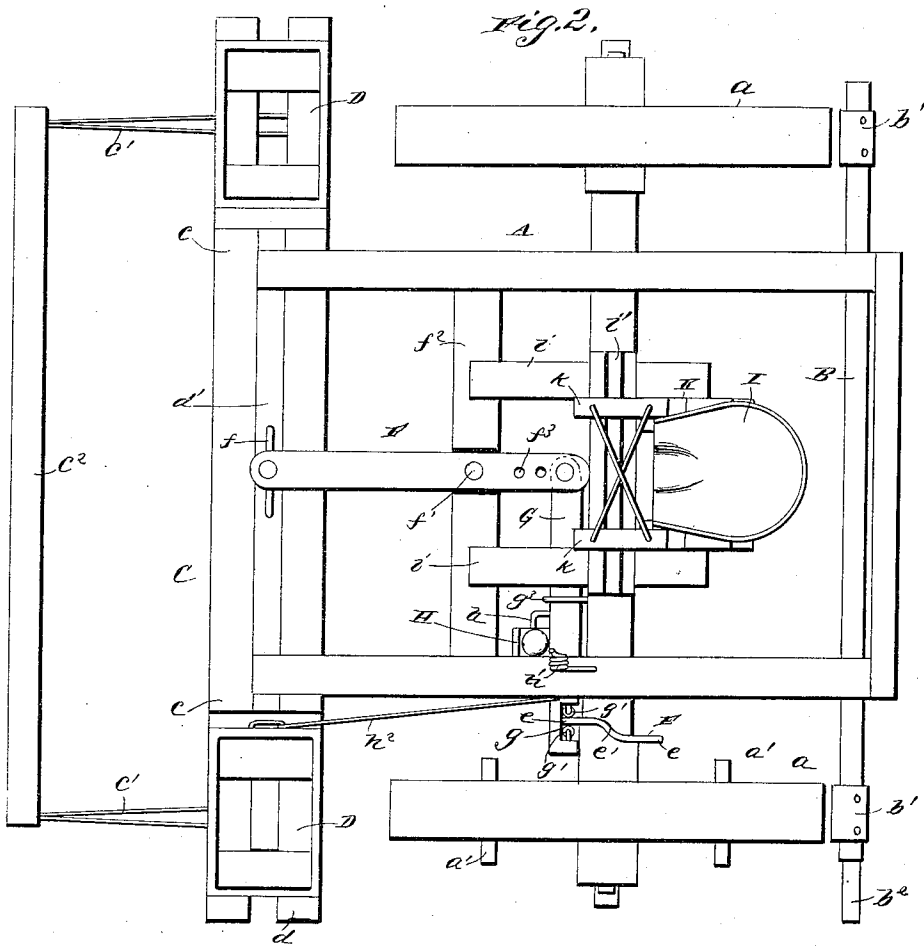

Witnesses

*B. Taylor*

*E. Y. Siggen*

Inventor

*Robert A. Young*

By his Attorneys,

*C. A. Snow & Co*

# UNITED STATES PATENT OFFICE.

ROBERT ARTHUR YOUNG, OF WAYNE, IOWA.

## SEED OR CORN PLANTER.

SPECIFICATION forming part of Letters Patent No. 366,752, dated July 19, 1887.

Application filed March 19, 1887. Serial No. 231,570. (No model.)

*To all whom it may concern:*

Be it known that I, ROBERT ARTHUR YOUNG, a citizen of the United States, residing at Wayne, in the county of Henry and State of Iowa, have invented a new and useful Improvement in Seed or Corn Planters, of which the following is a specification.

The invention relates to improvements in seed or corn planters; and its object is to provide a strong and durable machine of simple construction which will automatically mark the hills immediately after planting, in which the marker, if not scoring properly, can easily be adjusted to do so, in which the weight of the driver can be easily and quickly thrown upon the forward part of the main frame, so as to make the runners or furrow-openers enter the soil more deeply, and in which in turning the actuating-cam can be quickly and readily thrown out of gear with the lever actuating the seed-slide.

The invention consists in the construction and novel arrangement of parts, hereinafter described, illustrated in the drawings, and pointed out in the claims hereto appended.

In the accompanying drawings, Figure 1 is a perspective view of the improved planter. Fig. 2 is a plan view of the machine. Fig. 3 is a central vertical longitudinal section of the machine, showing the seat-frame in its forward position in dotted lines. Fig. 4 is a detail perspective view of the cam, the other parts actuating the seed-slide and the disengaging-lever.

Referring to the drawings by letter, A designates the main frame of the machine, having the axle secured to it, and the wheels *a a* turning loosely on the axle. The wheels have secured to their peripheries the transverse marker-bars *a' a'* diametrically opposite to each other, and so situated as to mark each hill as it is planted from the adjacent seed-box.

B is a scraper-shaft capable of being turned in journals *b b*, secured to the under surface of the rear end of the main frame, and *b' b'* are scraper-plates secured upon said shaft in such positions that by turning the shaft their edges can be brought to bear on the peripheries of the corresponding wheels, so as to scrape the same.

On the same side of the machine as the act-

uating cam-disk the scraper-shaft is extended to form the handle *b<sup>2</sup>*, by means of which the adjacent side of the machine can be lifted and the wheel turned to set the marker-bars in proper positions.

C is the runner-frame pivoted through the standards *c c* to the front ends of the longitudinal side rails of the main frame, and provided with the curved runners *c' c'*, extending from the transverse draft-bar *c<sup>2</sup>* to the lower ends of the posts *c<sup>3</sup> c<sup>3</sup>*, the two plates of the runners embracing and being secured to the sides of the posts.

D D are the seed-boxes, respectively secured to the ends of the rear rail, *d*, of the runner-frame, and *d'* is the seed-slide, moving between the two parallel strips of said rear rail, which strips are connected by the floors of the seed-boxes and by the standards *c c*. The seed-slide is of ordinary construction, and is actuated by the following mechanism:

E is a cam-disk secured upon the inner part of the hub of the marker-wheel and bent at diametrically-opposite points, so as to have equal opposite parts *e e* at right angles to the hub, but not in the same plane with each other. The said parts are connected by the similar inclined parts, *e' e'*, as shown.

F is a lever having its outer end connected by a loop on its under surface with the bail *f* on the central part of the seed-slide, so as to form a loose joint therewith, pivoted at *f'* upon a transverse rail, *f<sup>2</sup>*, of the main frame, in front of the axle, and having the end of its rear arm pivoted to the inner end of an actuating-rod, G, hereinafter more fully described.

*f<sup>3</sup> f<sup>3</sup>* are a series of adjusting-openings in the lever F, by means of which openings and the pivotal pin of the lever the throw of the seed-slide can be increased or diminished.

The outer end of the actuating-rod G is provided in its rear side with a notch, *g*, into which the edge of the cam-disk E enters, the anti-friction rollers *g' g'*, which turn on pins secured within the notch, bearing on the inner and outer faces, respectively, of the cam-disk to give ease of motion.

*g<sup>2</sup>* is a supporting bar or rail for the actuating-rod G to slide on, and *g<sup>3</sup>* is a pin secured to the front of the axle and bearing on the upper surface of the actuating-rod to keep it properly aligned.

H is a lever-arm pivoted on the side rail of the main frame within easy reach of the driver's seat, and having the end of its lower arm inserted in a loop, *h*, secured to the front side of the actuating-rod G, and *h'* is a spring secured to the main frame and bearing upon the lever in such manner as to force the actuating-rod and cam-disk into engagement. It is evident that the driver by pulling on the upper arm of said lever can disengage the actuating-rod and cam-disk when necessary.

*h<sup>2</sup>* is a rod or wire connecting a staple secured to the actuating-rod near its outer end with a staple secured to the seed-box on the same side, so that when the runner-frame is turned on the main frame in such direction as to prevent the runners from entering the soil the rod *h<sup>2</sup>* will automatically disengage the actuating-rod and cam-disk and stop the motion of the seed-slide.

I is the driver's seat, secured upon a vibratory frame, K, composed of the four similar bars, *k k*, pivoted at their lower ends to the longitudinal rails *i i* of the main frame and at their upper ends to the base of the seat, and the brace-rods *k' k'*, which truss and stay the said bars. The driver can by a suitable motion of his body throw the seat either forward or rearward until the edges of the bars *k* bring up against the rear or front edge of the transverse rail *j*, secured at its ends to the upper surface of the rails *i i*, between the front and rear pairs of bars. When the driver throws the seat, and consequently his weight, forward, it brings the latter in a position more directly above the runner-frame, and consequently drives the runners more deeply into the soil. When he throws the seat rearward, his weight causes the front part of the runner-frame to turn downward on the main frame and disengage the actuating-rod and the cam-disk, as described.

The seat will be horizontal in all positions in which the main frame is horizontal, so that it will always be comfortable and convenient for the driver. This is because the front bars and their brace-rods form a parallel-motion mechanism.

The planter constructed as herein described, while of simple construction, is strong, durable, and effective.

Having described my invention, I claim—

1. In a corn or seed planter, the combination, with the main and runner frames connected together, as described, so as to move up and down on each other at their points of connection, the cam-disk secured to the hub of one of the wheels, the driver's seat, and the parallel-motion device supporting said seat and composed, essentially, of the bars pivoted at their lower ends upon the main frame, of the seed-slide, the lever pivoted on the main frame and having its outer arm attached to said slide, the actuating-bar pivoted at its inner end to the inner arm of said lever, and provided with a notch near its outer end to engage the edge of the cam-disk, and the rod

or wire connecting staples on the actuating-rod, and the adjacent seed-box, whereby the actuating-rod is pulled out of engagement with the cam-disk when the driver throws the seat and his weight rearward, substantially as specified.

2. In a planter, the combination of the seed-slide, the lever F, connected thereto, the reciprocating rod G, connected to the lever F, the cam E, engaging the rod to reciprocate the same, the said rod being movable from the cam, the lever H, connected to the rod G, for the purpose set forth, and the spring *h'*, pressing against the lever H, and thereby causing the latter to keep the rod G normally in engagement with the cam, substantially as described.

3. In a planter, the combination, with the seed-slide, and the lever pivoted to the main frame and having its outer arm attached to said slide by a loose joint, of the cam-disk secured to the hub of the wheel, the actuating-rod provided with a notch having anti-friction rollers to engage against the surfaces of said disk on each side of its edge and pivoted at its inner end to the lever attached to the seed-slide, the supporting-rail and retaining-pin for the actuating-rod, and the spring-controlled disengaging-lever pivoted on the main frame and having the end of its lower arm engaged in a loop secured to the actuating-rod, substantially as specified.

4. The combination, in a planter, of the main frame having the axle on which it is balanced, the wheels on the said axle, and the cam attached to the hub of one of the wheels, the runner-frame hinged to the front end of main frame and having the seed-slide and the seed-hoppers, the lever F, connected to the said slide and fulcrumed to the main frame, the reciprocating rod G, connected to the lever F and having one end engaging the cam and movable thereon, the spring keeping the rod G normally engaged with the cam, and the rod *h<sup>2</sup>*, connecting the free end of rod G and one of the hoppers, for the purpose set forth, substantially as described.

5. In a planter, the combination, with the main frame, the marking-wheel turning freely on the axle, and marker-bars secured transversely to the periphery of said wheel, of the scraper-shaft turning in bearings secured to the main frame, and having the end on the same side as the marking-wheel prolonged and formed into a handle, whereby the adjoining side of the main frame can be lifted and the marking-wheel set in position for the marker-bars to score properly, substantially as specified.

In testimony that I claim the foregoing as my own I have hereto affixed my signature in presence of two witnesses.

ROBERT ARTHUR YOUNG.

Witnesses:

DAVID M. YOUNG,  
JAMES H. REED.