



(12) **EUROPEAN PATENT APPLICATION**

(88) Date of publication A3:
17.10.2001 Bulletin 2001/42

(51) Int Cl.7: **D01H 5/28**, D01H 4/48,
D01H 4/02, D01H 1/115

(43) Date of publication A2:
31.01.2001 Bulletin 2001/05

(21) Application number: **00109281.6**

(22) Date of filing: **28.04.2000**

(84) Designated Contracting States:
**AT BE CH CY DE DK ES FI FR GB GR IE IT LI LU
MC NL PT SE**
Designated Extension States:
AL LT LV MK RO SI

(71) Applicant: **Murata Kikai Kabushiki Kaisha**
Minami-ku, Kyoto-shi, Kyoto 601 (JP)

(72) Inventor: **Sawada, Harutoshi,**
c/o Murata Kikai Syataku 307gou
Kyoto-shi, Kyoto (JP)

(30) Priority: **28.07.1999 JP 21402599**
31.08.1999 JP 24608899
15.11.1999 JP 32369799

(74) Representative: **Liedl, Christine, Dipl.-Chem. et al**
Albert-Rosshaupter-Strasse 65
81369 München (DE)

(54) **Spinning device and method**

(57) The present invention provides a spinning device that can reduce errors during preparations for joining and that enables stable joining. In a true-twist spinning device S including a hollow guide shaft 15 having a spun-yarn passage 23 through which a spun yarn Y passes, and spinning nozzles 14 for generating whirling air currents near a tip of the hollow guide shaft 15, the spun-yarn passage 23 is formed to broaden toward a yarn ejection side, and yarn picking-up nozzles 29 are provided in the middle of the spun-yarn passage 23 for injecting compressed air. By injecting compressed air from the yarn picking-up nozzles 29 during joining, a suction force is generated in the spun-yarn passage 23 to allow a fiber bundle 6, which have been whirled by the spinning nozzles 14, to be introduced into the spun-yarn passage 23 for yarn picking-up spinning.

FIG. 2

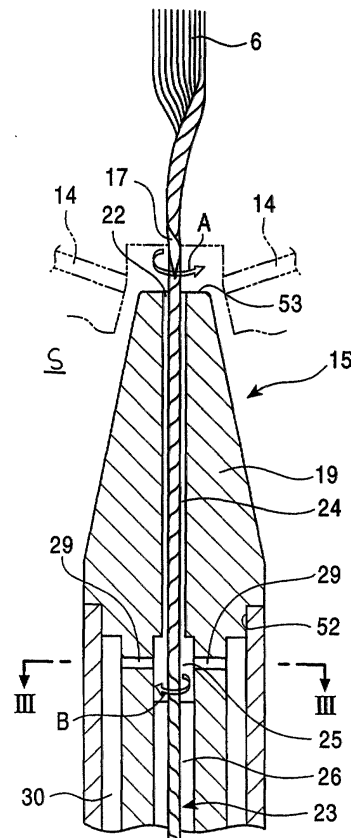



European Patent Office

EUROPEAN SEARCH REPORT

Application Number
EP 00 10 9281

DOCUMENTS CONSIDERED TO BE RELEVANT			
Category	Citation of document with indication, where appropriate, of relevant passages	Relevant to claim	CLASSIFICATION OF THE APPLICATION (Int.Cl.7)
X	US 5 088 265 A (TAKESHITA AKIHIKO ET AL) 18 February 1992 (1992-02-18)	10	D01H5/28 D01H4/48
A	* column 4, line 1 - column 5, line 2; figure 1 *	1-9, 11-14	D01H4/02 D01H1/115
A	--- PATENT ABSTRACTS OF JAPAN vol. 009, no. 283 (C-313), 9 November 1985 (1985-11-09) & JP 60 126330 A (MURATA KIKAI KK), 5 July 1985 (1985-07-05) * abstract *	10	
A	--- US 4 825 633 A (ARTZT PETER ET AL) 2 May 1989 (1989-05-02) * column 3, line 62 - column 5, line 23; figures 1-8 *	1,10	
			TECHNICAL FIELDS SEARCHED (Int.Cl.7)
			D01H
The present search report has been drawn up for all claims			
Place of search		Date of completion of the search	Examiner
THE HAGUE		3 August 2001	Henningsen, O
CATEGORY OF CITED DOCUMENTS			
X : particularly relevant if taken alone Y : particularly relevant if combined with another document of the same category A : technological background O : non-written disclosure P : intermediate document		T : theory or principle underlying the invention E : earlier patent document, but published on, or after the filing date D : document cited in the application L : document cited for other reasons ----- & : member of the same patent family, corresponding document	

EPO FORM 1503 03/82 (P04C01)

**ANNEX TO THE EUROPEAN SEARCH REPORT
ON EUROPEAN PATENT APPLICATION NO.**

EP 00 10 9281

This annex lists the patent family members relating to the patent documents cited in the above-mentioned European search report. The members are as contained in the European Patent Office EDP file on
The European Patent Office is in no way liable for these particulars which are merely given for the purpose of information.

03-08-2001

Patent document cited in search report	Publication date	Patent family member(s)	Publication date
US 5088265 A	18-02-1992	JP 1118628 A	11-05-1989
		CH 679679 A	31-03-1992
		DE 3837070 A	18-05-1989
		IT 1224290 B	04-10-1990
JP 60126330 A	05-07-1985	JP 1029893 B	14-06-1989
		JP 1545781 C	28-02-1990
US 4825633 A	02-05-1989	DE 3541219 A	27-05-1987
		BR 8606942 A	03-11-1987
		CN 86107922 A, B	10-06-1987
		CS 8608474 A	16-12-1992
		DE 3665889 D	02-11-1989
		WO 8703308 A	04-06-1987
		EP 0222981 A	27-05-1987
		IN 168020 A	19-01-1991
		JP 63503394 T	08-12-1988
		SU 1806228 A	30-03-1993