

Nov. 10, 1936.

A. TROPIANO

2,060,701

INTERLOCKING BUILDING BLOCK FACING

Filed June 4, 1934

2 Sheets-Sheet 1

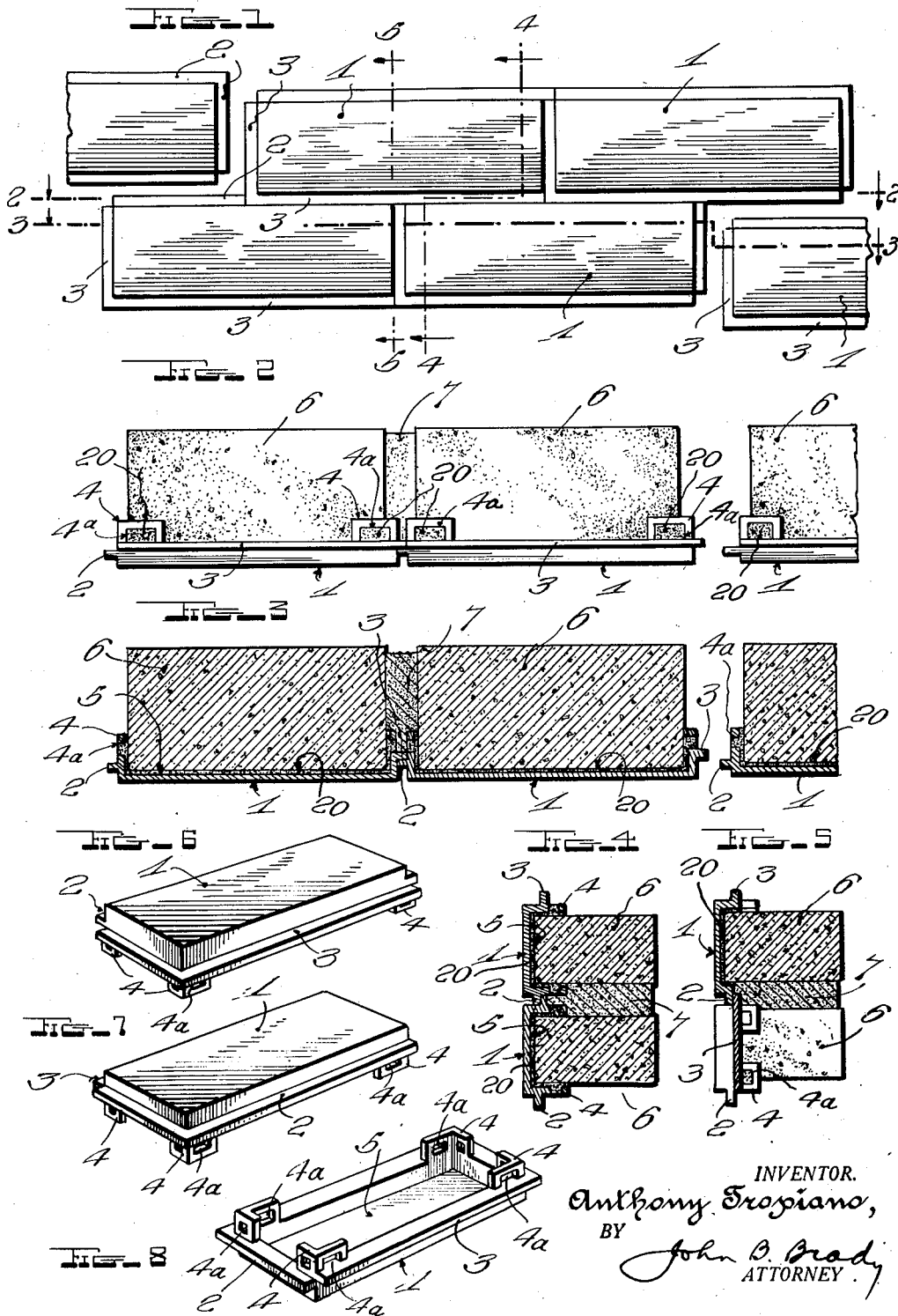

INVENTOR.
Anthony Troiano,
BY *John B. Brady*
ATTORNEY

Nov. 10, 1936.

A. TROPIANO

2,060,701

INTERLOCKING BUILDING BLOCK FACING

Filed June 4, 1934

2 Sheets-Sheet 2

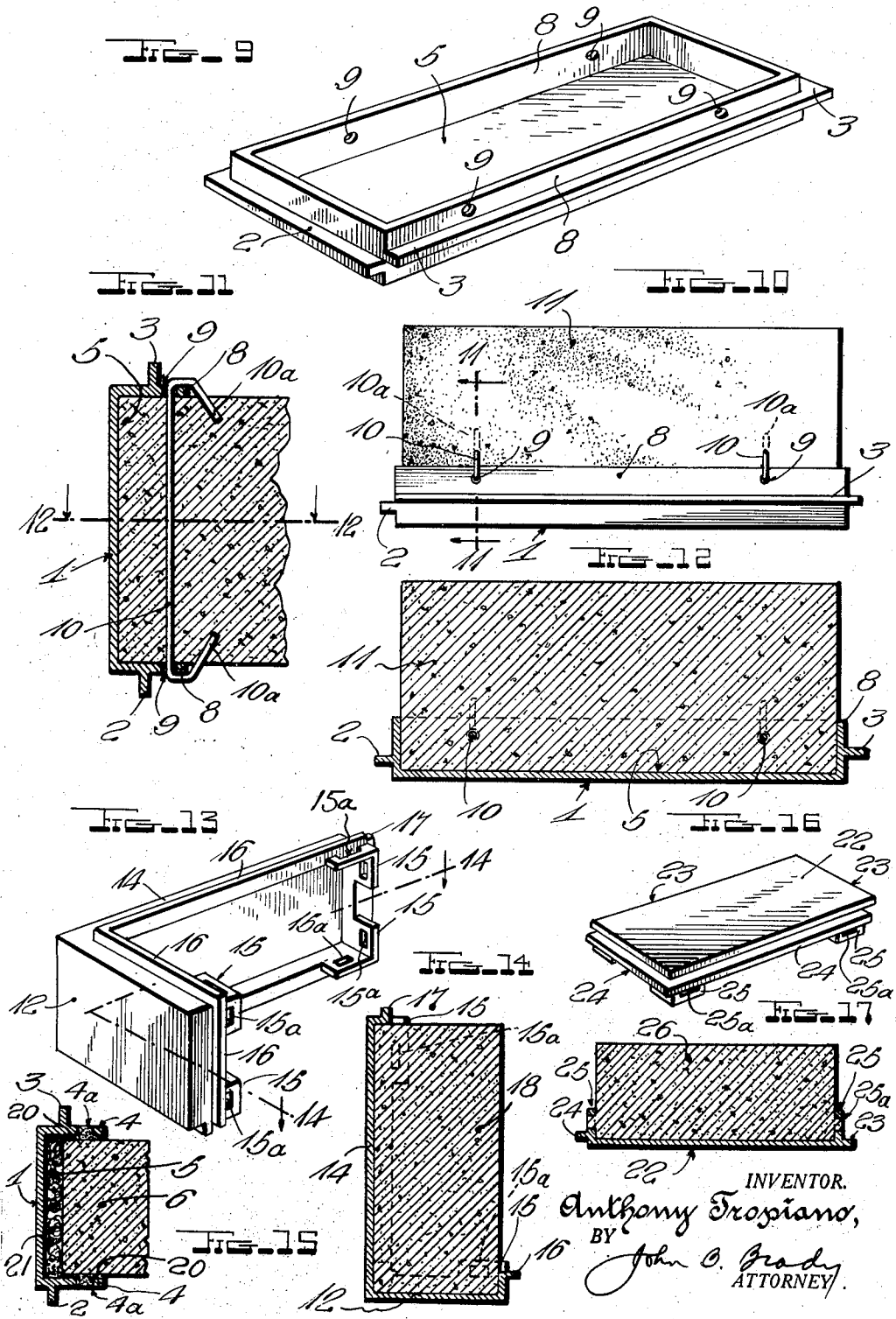

INVENTOR.
Anthony Tropiano,
BY
John O. Brady
ATTORNEY.

UNITED STATES PATENT OFFICE

2,060,701

INTERLOCKING BUILDING BLOCK FACING

Anthony Tropiano, Greenwich, Conn.

Application June 4, 1934, Serial No. 728,965

13 Claims. (Cl. 72—35)

My invention relates broadly to building construction and more particularly to a structure of overlapping facing for use on building blocks.

One of the objects of my invention is to provide a construction of overlapping facing for use on building blocks for providing a preformed surface of uniform ornamental appearance in building construction.

Another object of my invention is to provide a construction of facing for building blocks having special means for effecting an overlap between the units of a wall structure for insuring a moisture-proof and ornamental seam between the units of the wall structure at the same time providing a uniform ornamental surface for the entire wall structure.

Still another object of my invention is to provide a construction of facing for bricks, which facing may be overlapped to provide a wall structure of substantial strength and uniform ornamental appearance while allowing bricks of relatively low cost to be employed in building construction.

A further object of my invention is to provide a construction of facing for building bricks wherein the facing may be secured over one face of the brick, said facing having means projecting from the sides thereof for providing an overlap with similar means on coacting facings carried by adjacent bricks to provide a moisture-proof tightly-seamed wall structure.

A still further object of my invention is to provide a construction of facing member applicable to bricks for permitting such bricks to be rapidly laid for quickly producing a wall structure of substantial strength and uniformity and relatively ornamental appearance without the necessity of seaming the external crevices between adjacent bricks with cement.

Another object of my invention is to provide a construction of facing for building bricks including means for reducing heat conduction through the building bricks by interposing heat insulation material between the brick and the inner surface of the facing to provide a completely fire-proof heat-insulating wall particularly adapted for ovens, chimneys, and fireplaces.

Still another object of my invention is to provide a construction of attachable facing for inexpensive poured-cement blocks wherein the facing may be secured in position over selected surfaces of said cement blocks, said facing being provided with peripheral flanges operative to coact with similar flanges on adjacent building blocks

for insuring a moisture-tight seal between the building blocks.

A further object of my invention is to provide a particular arrangement of overlapping peripheral flanges on an attachable building block facing in which the flange around one peripheral portion of the metallic facing is in one plane and the flange around the opposite peripheral portion is in another plane offset from the aforesaid plane by a specified distance for coaction with similarly arranged flanges on adjacent building blocks thereby automatically securing the proper horizontal and vertical alignment of the building blocks in a water-proof wall structure.

A still further object of my invention is to provide a construction of facing for building blocks in which each facing is formed with peripheral coacting flanges for overlapping adjacent facings in the same plane with a relatively narrow water-proof seam therebetween.

Other and further objects of my invention reside in the structure of facing employed for building blocks in accordance with my invention, as set forth more fully in the specification hereinafter following by reference to the accompanying drawings, in which:

Figure 1 illustrates the building construction of my invention and the manner in which the structural units of my invention are overlapped, forming a wall; Fig. 2 is a top plan view showing a wall structure formed by overlapped building units with one building unit about to be placed in position taken on line 2—2 of Fig. 1; Fig. 3 is a horizontal sectional view taken on line 3—3 of Fig. 1; Fig. 4 is a vertical sectional view through the building construction illustrated in Fig. 1 on line 4—4 of Fig. 1; Fig. 5 is a vertical sectional view through the building construction of my invention taken on line 5—5 of Fig. 1; Fig. 6 is a perspective view of one form of the facing constructed in accordance with my invention; Fig. 7 is a perspective view of the facing looking in the opposite direction from that in which Fig. 6 is viewed; Fig. 8 is a perspective view of the reverse side of the facing; Fig. 9 is a perspective view of the reverse side of a facing of a modified form of construction employed in my invention; Fig. 10 shows the application of the facing of my invention to a cement block; Fig. 11 is a fragmentary sectional view taken through a cement block showing the application of the facing of my invention thereto; Fig. 12 is a horizontal sectional view taken on line 12—12 of Fig. 11; Fig. 13 shows the facing of my inven-

tion applied to a corner building block for use in a wall structure; Fig. 14 is a horizontal sectional view through a building block equipped with a corner facing in accordance with my invention for installation in the corner of a wall construction, said view being taken on line 14—14 of Fig. 13; Fig. 15 is a fragmentary cross-sectional view showing my invention applied to a building unit in which special provision is made for the inclusion of heat insulation material interposed between the building block and the facing; Fig. 16 is a perspective view of a further modified form of facing embodying my invention; and Fig. 17 is a lateral cross-sectional view through a structural unit equipped with the facing illustrated in Fig. 16.

My invention is directed to a construction of attachable facing for building blocks. I provide a construction, preferably fabricated as a metallic casting, which is shaped to form a facing for a building block. The facing is provided with peripheral flanges projecting in two predetermined planes normal to the sides of the building block and parallel to the plane of the face of the building block. The flange around one peripheral portion of the facing is disposed in one plane while the diametrically opposite peripheral portion of the facing is provided with a flange disposed in a plane offset from the plane of the aforesaid flange by an amount equivalent to the thickness of the coating flange of the facing on an adjacent building block. An offset arrangement of the peripheral flanges on the castings constituting the facings for the building blocks allow the building blocks to be automatically aligned in proper horizontal and vertical directions as they are laid in position with layers of mortar between the building blocks. The peripheral flanges projecting from the facings contact to provide a tight weatherproof overlap which covers and protects the cement joints between the building blocks from the outside elements such as rain, wind, dampness and frost, thereby prolonging the structural life of a wall which is erected by use of blocks equipped with the facings of my invention. The facings enable relatively inexpensive building blocks, poured-cement blocks, or unfinished bricks to be used for exterior and interior construction such as walls for swimming pools; water-proof foundations; fireplaces; bathrooms; kitchens; subterranean walls; and other building structures. The facings are so disposed with overlapping flanges that water and dampness will not penetrate the wall. The wall will not disclose any visible cracks under conditions of the usual wall settlement so that the expense of striking-up joints is eliminated. The facings of the units constituting the wall structure may be fabricated from weatherproof metallic alloys or ceramics permitting the application of any desired finish or polish which adds considerably to the novelty and advantages of my invention. The outer surface of the facings may have a polish of high luster imparted thereto which will be substantially permanent in its characteristic thereby providing a permanently crack-free sanitary wall, the surface of which may be readily washed and cleaned, thereby particularly adapting it for use in hospitals and kitchens.

By reason of the fact that a brick wall, constructed in accordance with my invention, has the exterior surface thereof protected by overlapping weatherproof facings, radical changes in building construction are brought about by the

use of my invention. Such a brick wall, constructed with the facings on the exterior faces of the bricks, according to my invention, is substantially moisture-proof. Accordingly, on the interior of the brick wall, furring or lathing need not be provided as plaster can be applied directly to the interior of the brick wall without the interposition of furring, lathing or a dead air space as heretofore required. The elimination of the furring or lathing operation reduces both the material cost and the cost of building erection, at the same time reducing the fire-damage potentialities of the interior construction.

Where the building block construction of my invention is employed in furnace walls and other walls subject to relatively intense heat or cold, I provide a lining of rock wool or other heat insulation interposed between the inner surface of the facing and the face of the building block. Thus, a high thermal resistance is built up through the wall structure which includes both the material constituting the facing and the heat insulation lining between the inner surface of the facing and the face of the building block.

The use of the facings of my invention enables unfinished bricks of relatively low cost to be employed in building structures which have an ultimate appearance and durability equal and, in fact, better than building structures employing finished bricks of relatively high cost. The facings may be used with cement blocks which are formed on the building site at considerably less cost than is required when finished building bricks are used, since the comparatively high transportation expenses of bricks are eliminated. Cement blocks poured to a desired size and shape on the building site are allowed to set to a degree sufficient to insure the maintenance of form of the cement block, at which time, the facing of my invention is applied thereto and secured in position thereon. Thereafter, the block is allowed to set and form a substantial union with the facing. The facing once united with the cement block provides a durable self-aligning building unit which may be quickly overlapped with others of similar type, thus expediting the erection of a wall by eliminating the necessity of repeating the usual leveling and aligning processes. This results in a substantial reduction in labor costs by shortening the erection time required and yet makes possible a more attractive wall surface than has heretofore been obtained in building construction.

Referring to the drawings in detail, reference character 1 designates the form constituting the facing, the several facings for adjacent bricks being illustrated in cooperative overlapping relation in the positions which the bricks assume in the erection of a wall structure. I have illustrated in Fig. 1, the manner in which the peripheral flanges on the castings forming the facings for the bricks extend around the entire periphery of the facing in such manner that the upper and right hand peripheral flanges of each facing are overlapped by the lower and left hand flanges of adjacent facings. The offset relation of the peripheral flanges permitting this form of overlapping arrangement is shown more clearly in the perspective view of the facing illustrated in Fig. 9. One peripheral flange which projects from one end and one side of the facing is indicated by reference character 2. The opposite peripheral flange which projects from the opposite end and the opposite side of the facing is indicated by reference character 3. The offset

relationship of the peripheral flanges 2 and 3 enables the bricks or blocks to which the facings are applied to be evenly laid in level courses and the courses automatically maintained true with all joints even. The coating flanges on adjacent facings overlap by the thickness of the flanges forming a moisture-tight joint. In the forms of my invention, illustrated in Figs. 1-15 the flanges are offset in a plane removed from the plane of the facing 1. In a modified form of my invention, however, I project a portion of the peripheral flanges in a plane coincident with the plane of the facing, as set forth more fully in Figs. 16 and 17 and which will be described hereinafter in more detail.

The facing is provided with a set of rearwardly projecting angle members, preferably formed integral with the facing 1 and designated at 4. The angle members 4 are disposed in diagonally opposite corners of the inner surface of the facing 1. The angle members 4 form continuations of the pocket or recess 5 formed by the inner surface of the facing 1. The depth of the recess 5 is determined by the thickness of the facing 1 and the distance of its forward projection from the flanges.

Each of the angle members 4 is apertured at 4a to provide means for readily securing the facing to the building block or brick by the application of mortar or cement around the building block or brick designated at 6 and through the apertures 4a. The apertures 4a are of sufficient size to allow enough mortar or cement to pass therethrough as will provide a firm seal between the facing and the brick or building block. The projections of the angles are such that the brick or building block may be readily fitted into the recess 5 and the diagonally opposite corners of the angles 4.

The facings are first applied to the brick or building block indicated at 6 and firmly secured thereon by the bond obtained by means of the mortar filling the apertures 4a and by the aid of a thin layer of mortar spread between the face of the brick and the recess 5 in the metallic facing, indicated at 20. The reason for the offset arrangement of the opposite peripheral flanges will be clearer from a consideration of Figs. 4 and 5. After the first course of bricks is laid with the facings in overlapped position with respect to horizontally adjacent bricks, a layer of mortar 7 is spread over the bricks and the next succeeding course of bricks is laid in position thereover with the peripheral flange 2 of the facings on the brick in the upper layer exteriorly overlapping the peripheral flange 3 of the facings on the brick in the lower layer. The peripheral flange 3 on the facings of the layer of brick just described extend upwardly to form an abutment for the flange projections 2 on the facings of the next succeeding layer of brick.

Similarly, the end to end abutment of the facings is formed by end-flange 2 overlapping end-flange 3 providing a weatherproof seal between the bricks 6 and preventing the entrance of moisture to the layer of mortar between the bricks at 7. In some instances, the angle members 4 at the corners of the bricks are not formed, as shown, with apertures 4a, but in lieu thereof, a rearwardly projecting flange indicated at 8 in Fig. 9 is extended wholly around the rear of the facing. This form is used particularly in instances where cement building blocks are employed and where the facing bearing sealing cement on its inner surface is forced over the selected surface of

the building block while it is still in a somewhat plastic state. The rearwardly projecting flange 8 is apertured at 9 in similarly aligned positions to enable a securing wire member 10, Figs. 10 and 11, which may be inserted into the mass of the cement block 11 while it is plastic, to have the ends thereof pass through the apertures 9 and bent over to positions 10a for securing the facing rigidly in position over the face of the cement block 11. As the sealing cement and the block harden, the cement adheres to the inner surface of the recessed portion 5 of the facing, which is rough, and to the interior of the rearwardly projecting flange 8. The wire member 10 becomes firmly anchored in the aggregate of the block 11. The offset peripheral flanges 2 and 3 project in offset planes as heretofore described and provide moisture-tight overlapping seams.

Where the facing of my invention is used on the corners of walls, the facings are formed, as shown in Fig. 13, wherein one outer surface of the facing, 12, extends normal to the remainder of the surface of the facing, 14. A rearwardly projecting angle member 15 extends normal to each surface 12 and 14 of the facing in the positions shown. The peripheral flange 16 projects from the end of the facing which terminates in surface 12 and from the upper edge of facing 12 and from the upper edge of surface 14 of the facing. The peripheral flange 17 which is offset in another plane toward outer surfaces 12 and 14 extends from the end of the facing which terminates in surface 14 and from the lower edges of surfaces 14 and 12 of the facing. The corner block 18, Fig. 14, has the facing surfaces 12 and 14 secured thereto by cement or mortar which is forced through apertures 15a in the rearwardly projecting angle members 15 and spread over a portion of the block.

There are a number of instances in which heat insulation is a vital consideration in the erection of a brick wall. Such conditions are encountered in brick walls used for ovens, furnaces, refrigerators, and other heat-insulated structures. In such instances, I prefer to employ the arrangement illustrated in Fig. 15 in which a layer of rock wool or other heat insulation material represented at 21 is spread on the rear surface of the facing, shown at the recess 5 and forms a heat-insulating layer between the face of the brick 6 and the rear surface of facing 1. The facing is secured to the brick 6 in a manner similar to that described heretofore such as by means of the bond produced by the cement or mortar interlock through apertures 4a in angles 4. The peripheral flanges 2 and 3 are provided as heretofore explained for insuring a flame or moisture-proof overlapping seam between adjacent bricks.

There are numerous instances in which it is desirable to have the facings extend in a substantially continuous plane without appreciable gaps or crevices therebetween. Constructions of this nature are especially desirable in wall surfaces for bathrooms, kitchens, hospitals, and other places where a high degree of sanitation is essential. For such instances, I provide a special structure of facing, as illustrated in Figs. 16 and 17 wherein the outer surface of facing 22 is in the same plane with the peripheral extension on one end and side of the facing, as shown at 23. A peripheral flange is formed integral with facing 22 but offset rearwardly therefrom in a plane for a distance equal to the thickness of the peripheral flange 23, projecting from the opposite end and opposite side of the facing, as represented at 24.

Rearwardly projecting angle members 25 are provided on the facing with bonding apertures 25a therein for allowing the facing 22 to be secured over the bricks or blocks 26. The bricks or blocks 26, Fig. 17, are laid in such manner that the facings 22 have their lower and left-hand peripheral portions 23 overlapping the upper and right-hand peripheral portions 24 of adjacent facings. This arrangement insures a continuous flat surface in which the facings are all in one plane with the degree of overlap of the peripheral portions such that only an extremely narrow seam remains between the adjacent facings.

I have found the building construction of my invention highly practical. A wall constructed with brick equipped with metal facings formed in accordance with my invention provides an extremely rigid structure which is substantially permanent. A wall equipped with the metal facings of my invention may even be subjected to reasonable displacement, such as encountered in earthquake zones without substantial injury to the wall structure due to the tendency of the metal overlapping peripheral flanges to hold all the bricks in a wall in the same plane and to prevent the opening of cracks between bricks even though the structure is subjected to considerable shock or other dangerous pressure.

The fact that the facings of my invention may be cast, molded, or fabricated from stampings, reduces the cost thereof. Various ornamental finishes may be applied to the exposed surface of the cast facing. The outer surface of the facing may be finely finished and polished to impart a permanent luster to the facing or the surface may be sand-blasted to give a mat effect, such surfaces producing a highly ornamental appearance to a finished wall structure. It will be readily appreciated that brick of lower cost may be used in the erection of walls when equipped with the facings of my invention, that more rapid structure of the walls is made possible, and that furring and lathing may be eliminated, thereby bringing about a condition where the total material costs are not greatly increased, if at all, while labor costs are actually reduced and the speed of erection of buildings increased.

While I have described my invention in certain preferred embodiments, I desire that it be understood that modifications may be made and that no limitations upon my invention are intended other than are imposed by the scope of the appended claims.

What I claim as new and desire to secure by Letters Patent of the United States is as follows:

1. A facing for building blocks comprising a member formed to engage the face of a building block, oppositely and outwardly extending semi-peripheral flanges formed on said member, the plane of one of said semi-peripheral flanges being offset from the plane of the opposite semi-peripheral flange for a distance equal to the thickness of the first mentioned semi-peripheral flange.

2. A facing for building blocks comprising a member having a recess in one side thereof for receiving a building block and a plane surface on the opposite side thereof, and longitudinally extending flanges on opposite peripheral portions of said member, the flanges opposite each other being offset in different planes.

3. A facing for building blocks comprising a member having a recess in one side thereof for receiving a building block and a plane surface on the opposite side thereof, and longitudinally extending flanges on opposite peripheral portions of

said member, the flanges opposite each other being offset from each other in planes spaced apart for a distance equal to the thickness of said flanges.

4. A facing for building blocks comprising a member having a recess in one side thereof for receiving a building block and a plane surface on the opposite side thereof, and longitudinally extending flanges on opposite peripheral portions of said member, the flanges opposite each other being offset from each other in planes spaced from each other for a distance equal to the thickness of the flanges and means integral with said member for establishing an interlocking connection with the building block.

5. A facing for building blocks comprising a member shaped to engage the face of a building block, oppositely and outwardly extending semi-peripheral flanges formed on said member, the plane of one of said semi-peripheral flanges being offset from the plane of the opposite semi-peripheral flange for a distance equal to the thickness of the first mentioned flange, and means for establishing an interlocking connection of said member with adjacent corners of the building block.

6. A facing for building blocks comprising a member shaped to engage the face of a building block, oppositely and outwardly extending semi-peripheral flanges formed on said member, the plane of one of said semi-peripheral flanges being offset from the plane of the opposite semi-peripheral flange for a distance equal to the thickness of the first mentioned flange, and means integral with said member for establishing an interlocking connection thereof with adjacent corners of the building block.

7. In a wall structure comprising a multiplicity of layers of superimposed blocks, facing members for each of said blocks having longitudinally extending semi-peripheral flanges integral with each of said facing members, a portion of the semi-peripheral flange on one of said facing members extending in overlapping relation with a portion of the semi-peripheral flange on adjacent facing members.

8. In a wall structure comprising a multiplicity of layers of superimposed blocks, facing members for each of said blocks, each of said facing members having a pair of oppositely and outwardly projecting flanges, each flange being a normal projection extending in a common plane from one end and a side wall of said facing member, the plane of one of said flanges being offset from the plane of the opposite flange by an amount substantially equal to the thickness of the aforementioned flange whereby the flanges of one facing member overlap with the flanges of adjacent facing members for establishing a weather-tight connection between said facing members.

9. A facing member for a building block comprising a pair of flat integrally related plate-like sections, the side and end portion of one of said plate-like sections extending beyond the corresponding side and end portion of the adjacent plate-like section, and means for establishing a connection between the rear of said facing member and a building block.

10. A facing member for a building block comprising a pair of flat integrally related plate-like sections, the side and end portion of one of said plate-like sections extending beyond the corresponding side and end portion of the adjacent plate-like section, and the opposite side and end portion of said last mentioned plate-like section extending beyond the corresponding side and end

portion of said first mentioned plate-like section, and means for establishing a connection between the rear of said facing member and a building block.

5 11. A structural unit comprising a molded building block, wire members extending through said molded building block, a facing member having a recess in its rear surface for receiving one face of said molded building block, and means projecting from the rear of said facing member and engaging said wire members for maintaining said facing member in position with respect to said building block.

10 12. A structural unit comprising a building block, a facing member for said building block, said facing member having a flat surface on one side thereof and a recess opposite said flat sur-

face, and means projecting from the rear of said facing member for centering said building block in the recess in the rear of said facing member, said last mentioned means being apertured for the passage of bonding material therethrough 5 for insuring a firm connection between said building block and said facing member.

13. A facing member for a building block comprising a body structure having a flat outer surface disposed in one plane, a semi-peripheral 10 flange disposed in a plane parallel to said outer surface, and a complementary flange disposed in a plane parallel to but offset from the plane of the aforesaid flange, and means for establishing a connection between the rear of said facing 15 member and a building block.

ANTHONY TROPIANO.