

A. M. BURNHAM,
WASHING MACHINE.

APPLICATION FILED JULY 23, 1910.

Patented May 9, 1911.

2 SHEETS—SHEET 1.

991,946.

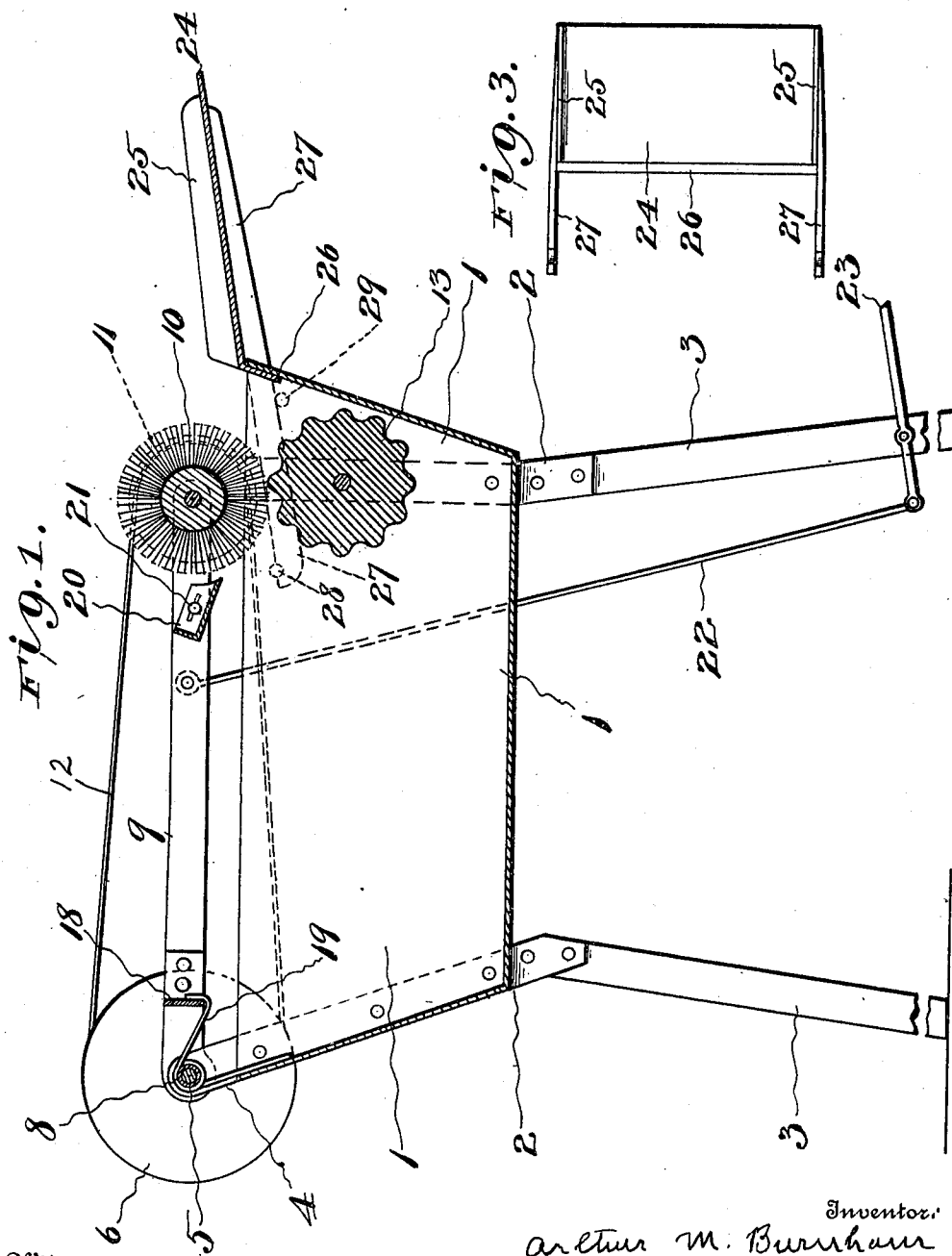

Witnesses

John H. Blackwood
W. C. Blackwood

Inventor:
Arthur M. Burnham

By *James K. Peck*

Attorney

UNITED STATES PATENT OFFICE.

ARTHUR M. BURNHAM, OF GARDINER, MAINE, ASSIGNOR TO NATIONAL SPECIALTY COMPANY, OF WASHINGTON, DISTRICT OF COLUMBIA, A CORPORATION OF NEW JERSEY.

WASHING-MACHINE.

991,946.

Specification of Letters Patent.

Patented May 9, 1911.

Application filed July 23, 1910. Serial No. 573,530.

To all whom it may concern:

Be it known that I, ARTHUR M. BURNHAM, a citizen of the United States, and a resident of Gardiner, in the county of Kennebec and State of Maine, have invented certain new and useful Improvements in Washing-Machines, of which the following is a specification.

My invention relates to machines for washing fabrics and has for its object the provision of a machine that very closely imitates the rubbing administered by hand on the familiar wash-board, and consists in the provision of a corrugated roller that is mounted to rotate in a suitably constructed receptacle, and a rotary brush journaled in the free end of a pivoted frame and connected to a foot-piece to hold the brush in the desired position relative to the roller in order to wash the clothes.

My invention will be described in detail hereinafter, and illustrated in the accompanying drawings, in which—

Figure 1 is a longitudinal sectional view of my improved washing machine; Fig. 2, a top plan view; and Fig. 3, a view on a reduced scale of the hand-board removed.

In the drawings similar reference characters will indicate corresponding parts throughout all of the views.

The receptacle 1 of my improved device is made preferably of sheet-metal and has its sides vertical, while the ends are inclined. The corners of the receptacle are reinforced by angle-pieces 2 that are extended below the bottom of the receptacle and have legs 3 secured thereto. At one end of the receptacle the corner-pieces 2 are extended above the top thereof, as shown at 4, and a shaft 5 is journaled therein, having belt-pulleys 6 and 7 secured thereto.

8 indicates a tubular shaft loosely mounted on shaft 5, and 9 arms secured to the shaft 8 and having a cylindrical brush 10 journaled therein with a pulley 11 secured thereto to one of its trunnions and geared to pulley 6 by means of belt 12.

13 indicates a corrugated scrubbing-roller journaled on the sides of the receptacle 1 adjacent to the end farthest removed from the end on which shaft 5 is journaled, said roller having a pulley 14 secured to one of its trunnions that is geared to pulley 7 by means of crossed belt 15, so that when in operation the roller and brush will pull the

clothes into the receptacle. Shaft 5 may be rotated by a crank-handle 16.

18 indicates a cross-bar connecting arms 9 and 19 a coil-spring mounted on shaft 8, and having one end engaging cross-bar 18 and the other end the end of receptacle 1. Said spring normally lifts the brush from engagement with the roller 13.

20 indicates a shelf mounted by means of bolts 21 on arms 9, on which cakes of soap may be placed, said shelf being adapted to be adjusted by means of the bolts to cause the soap to bear heavily or lightly on the brush, as desired, for the most efficient operation of the machine.

22 indicates a rod secured to each arm 9, and 23 a foot-bar secured to said rods, said bar being conveniently placed for operation by the operator of the machine to regulate the pressure of the brush on the fabric being treated.

24 indicates a hand-board having its side edges provided with flanges 25, and a flange 26 that engages the inner side of the end of the receptacle 1 adjacent to roller 13.

27 indicates arms secured to the side flanges 25 and engaging pins 28 and 29 on the sides of the receptacle to hold the board in place.

In operation the fabric to be treated is placed on board 24 and roller 13 and the arms 9 swung downwardly by depressing foot-bar 23, so that the brush 10 engages the top of the fabric. Then by resisting the tendency of the brush and roller to pull the clothes into the receptacle the fabric is effectually scrubbed, being allowed to be gradually pulled into the receptacle as the cleansing progresses.

Having thus described my invention, what I claim is—

1. In a washing-machine, a receptacle, a scrubbing-roller journaled in said receptacle, a shaft journaled in the receptacle, arms pivotally mounted on said shaft, a brush journaled in said arms, gearing connecting the shaft aforesaid and the roller and brush, and means to move the brush toward and from the roller, substantially as shown and described.

2. In a washing-machine, a receptacle, a scrubbing-roller journaled in said receptacle, a shaft journaled in the receptacle, arms pivotally mounted on said shaft, a brush journaled in said arms, gearing connecting

the shaft aforesaid and the roller and brush, a soap-shelf adjustably secured to said arms adjacent to said brush, and means to move the brush toward and from the roller, substantially as shown and described.

3. In a washing-machine, a receptacle, a scrubbing-roller journaled in said receptacle, a shaft journaled in the receptacle, arms pivotally mounted on said shaft, a brush journaled in said arms, gearing connecting the shaft aforesaid and the roller and brush, a spring to normally hold the arms in a raised position, and a foot-bar to depress the roller against the resistance of the spring, substantially as shown and described.

4. A washing-machine comprising a receptacle, a corrugated roller journaled in said receptacle, a drive-shaft journaled in

the receptacle and having pulleys secured thereto, a tubular shaft loosely mounted on said drive-shaft, arms secured to said tubular shaft, a brush journaled in said arms, a soap-shelf adjustably mounted on said arms, a spring engaging said arms and normally tending to raise them, gearing connecting the pulleys on the drive-shaft and the roller and brush, and a hand-board removably secured to the receptacle, substantially as shown and described.

In witness whereof, I have hereunto set my hand in presence of two subscribing witnesses.

ARTHUR M. BURNHAM.

Witnesses:

O. B. CLASON,
H. MABEL COBB.

Copies of this patent may be obtained for five cents each, by addressing the "Commissioner of Patents, Washington, D. C."
