

M. Rapp,

Water Wheel.

No. 104,199,

Patented June 14, 1870.

Fig. 1.

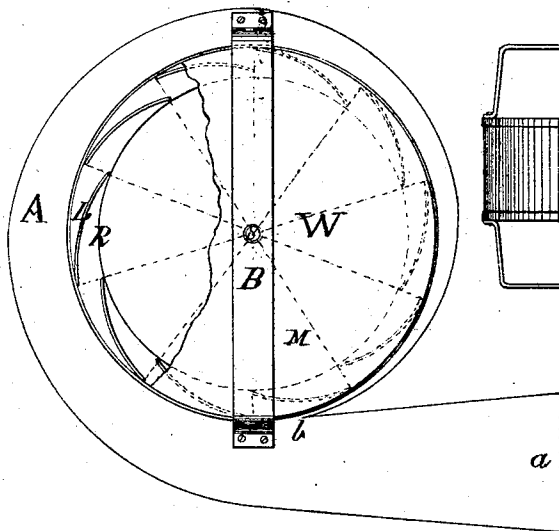

Fig. 2.

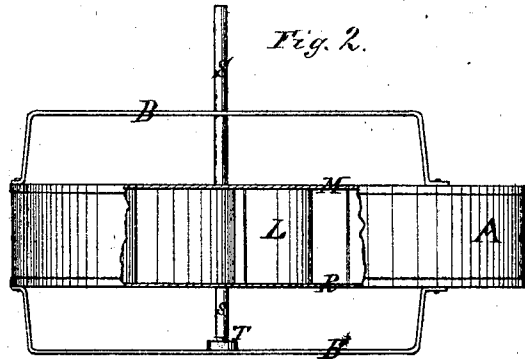

Fig. 3.

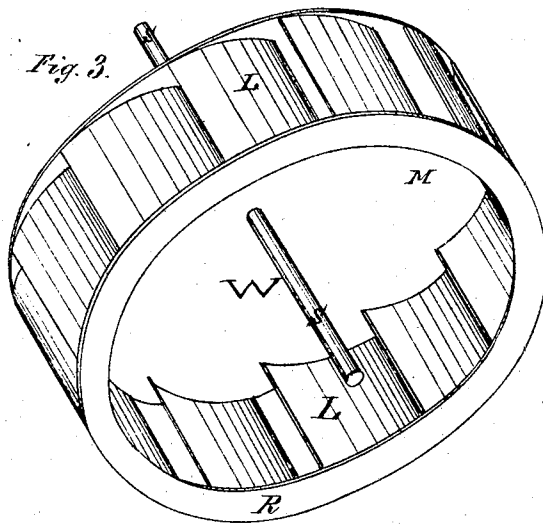
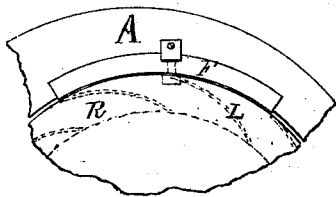

Fig. 4.



Witnesses.
R. W. Walker.
J. H. McKee

Matthias Rapp, Inventor
by Cox & Cox
his Attorneys.

United States Patent Office.

MATTHIAS RAPP, OF RAPP'S MILL, VIRGINIA.

Letters Patent No. 104,199, dated June 14, 1870.

IMPROVEMENT IN TURBINE WHEELS.

The Schedule referred to in these Letters Patent and making part of the same

To all whom it may concern:

Be it known that I, MATTHIAS RAPP, of Rapp's Mills, Rockbridge county, State of Virginia, have invented a new and improved "Water-Wheel;" and I do hereby declare the following to be an exact description thereof, reference being had to the accompanying drawings and to the letters of reference marked thereon making a part of this specification.

Nature and Object of the Invention.

The invention pertains to that class of water-wheels known as "turbine," and relates to providing the interior hollow space in the center of a scroll with a wheel of proper dimensions, which is closed on top, open on the lower side, and provided with concavo-convex buckets, the curves of which correspond to the curves of the wheel, which operates a vertical shaft rigidly secured to the vertical center of the wheel, the shaft resting upon a foot-block or journal below and properly secured above the wheel.

The object of the invention is to confine the water in the scroll casing, so that it acts upon all of the buckets simultaneously.

Description of the Accompanying Drawings.

Figure 1 is plan view of the invention, with a portion of the top of the wheel W broken out.

Figure 2 is a side elevation of the invention, with a portion of the vertical sides of the scroll broken out, showing the braces B and the shaft S.

Figure 3 is a perspective view of the buckets L and wheel W.

Figure 4 is a plan view of the block F, showing the manner of its attachment to the rim R.

General Description.

A, in the annexed drawings, is the scroll, which receives the water at its mouth, *a*, and thence gradually decreases in size by the converging of its vertical sides to a point directly opposite that at which the exterior vertical side comes in contact with the end of the opposite side of the mouth of the scroll at the point *b*.

The horizontal sides of the scroll have circular openings directly opposite each other, of sufficient diameter, and at such distance apart, as to allow the wheel W to revolve in the space between them, on all sides of which opening is the scroll-casing, open on the side adjacent to the wheel, but closed on the other sides.

This casing, beginning at the point *b*, gradually approaches the vertical surface of the sweep of the wheel W, until it meets the interior vertical side of the mouth of the scroll, at which point it is separated from the exterior face of the buckets L only a sufficient distance to allow the followers to pass freely.

The scroll is provided on its horizontal sides with raised or arched braces, B, sufficiently above and below the scroll to allow the wheel W free motion, the lower brace being provided with a foot-block, T, to support the shaft, the upper brace with a journal in which the shaft turns, both operating to preserve the shaft in a vertical position.

The wheel W nearly corresponds in diameter to the circular aperture in the upper and lower sides of the scroll, its thickness or height corresponding exactly with that of the circular parts of the scroll.

The top M of the wheel W is a circular disk, to the center of which the shaft S is firmly secured in a vertical position.

At a proper distance below the disk is placed a rim, R, of requisite width, and in exterior circumference corresponding to the disk M, between which and the rim R are placed the buckets L, their upper and lower edges being secured respectively to the disk M and rim R.

These buckets are concavo-convex in shape, their radii being equal to the radii of the disk, and are so placed as to fill the space between the disk and rim, the interior vertical edge of one of the buckets L being in the same vertical plane as the exterior vertical edge of the one immediately in front of it, the former edge being flush with the interior periphery of the rim R, the latter edge being flush with the circumference of the disk M and the exterior periphery of the rim R.

The disk M is in the same plane as the upper horizontal surface of the adjacent parts of the scroll.

The rim R is similarly located in relation to the lower horizontal surface of the adjacent parts of the scroll.

The wheel is provided at its exterior circumference with a sufficient number of blocks, F, to inclose it, which blocks are of a concavo-convex shape, the concavity conforming to the convexity of the wheel to the rim of which they are secured, in such manner as to revolve therewith, and to be screwed up to the wheel as it wears, their office being to prevent the escape of water through the space between the exterior circumference of the rim and the adjacent parts of the scroll.

Operation of the Invention.

Water being admitted at the mouth *a* of the scroll or volute A, it immediately impinges upon the convex faces of the buckets L, over which it flows, the waste water escaping through the openings between the concave and convex faces of the buckets, and thence through the opening in the rim in a reverse direction to the motion of the wheel; motion is thus obtained.

As the water follows the scroll-casing, it necessarily

is diminished in volume by the waste; but, as the motion of the wheel W carries it forward, as the buckets L completely fill the space between the disk M and rim R, as the distance between the exterior surfaces of the buckets L and the scroll A is gradually diminished, and as the escape of water through the space between the rim R and scroll A is in a great measure prevented, the scroll is almost immediately filled, and the water presses upon all of the buckets at once, thus causing the wheel to revolve, and with it the shaft S, to which attachments may be made for the purpose of applying the power.

The scroll may be cast in one piece of iron; the

disk M and rim R may be similarly made; the buckets should be formed of wrought or rolled metal.

Claims.

What I claim as my invention, and desire to secure by Letters Patent, is—

The water-wheel W, having the concavo-convex buckets L, and provided upon its periphery with the blocks F, in combination with the casing A, substantially as and for the uses and purposes described and shown.

Witnesses: MATTHIAS RAPP.

J. FRANKLIN REIGART,

EDM. F. BROWN.