

T. LIEB.

HYDRAULIC AIR PUMP.

No. 447,961.

Patented Mar. 10, 1891.

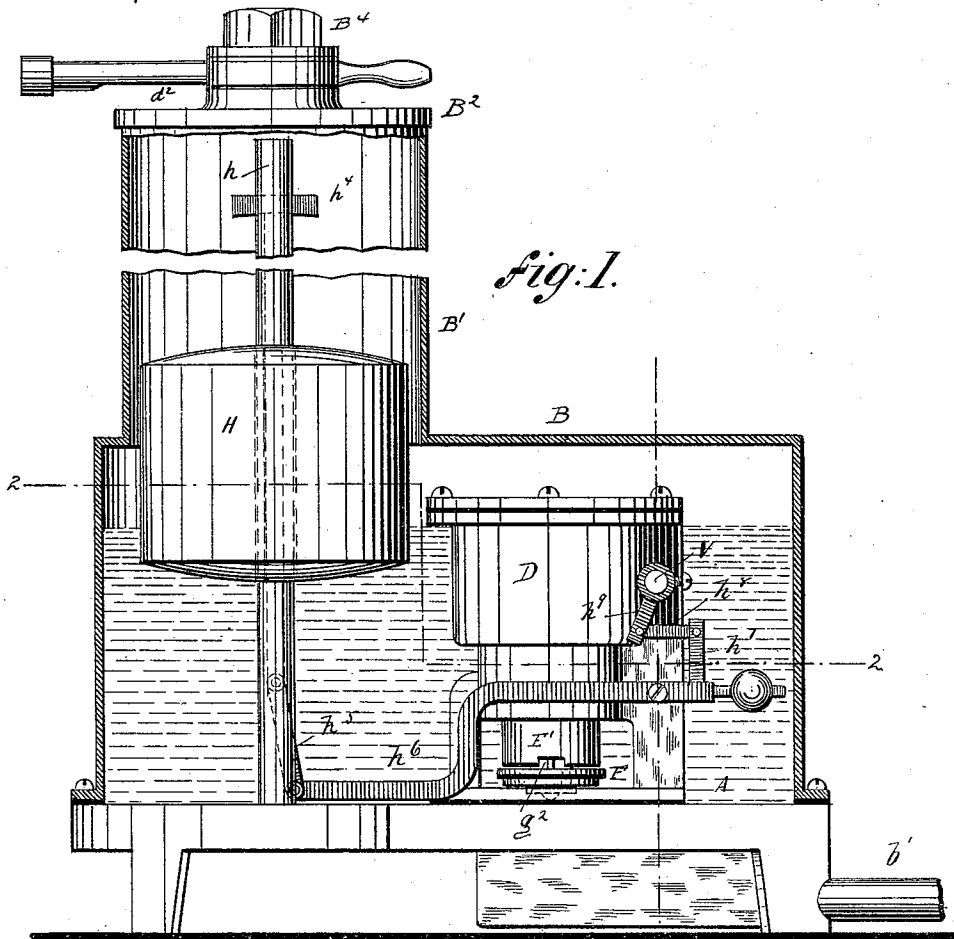

Fig. 1.

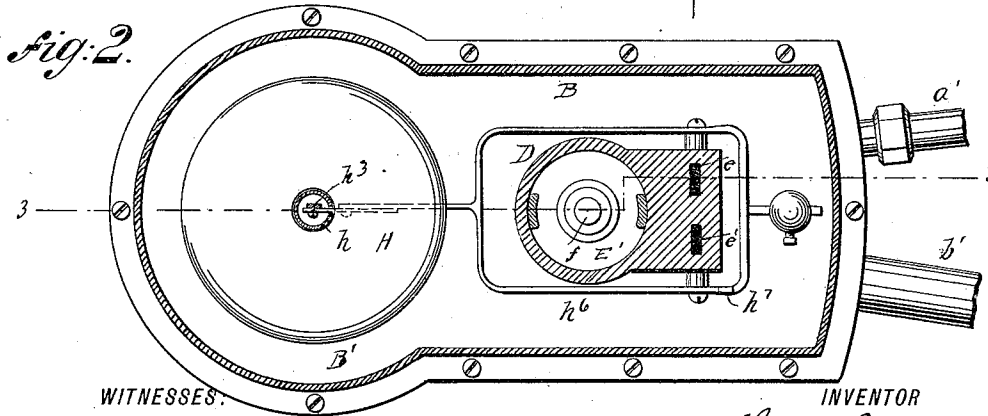

Fig. 2.

WITNESSES.

*A. Schehl.*  
*W. Kimball*

INVENTOR

*Thomas Lieb*  
 BY *Loyd & Raper*  
 HIS ATTORNEYS

T. LIEB.  
HYDRAULIC AIR PUMP.

No. 447,961.

Patented Mar. 10, 1891.

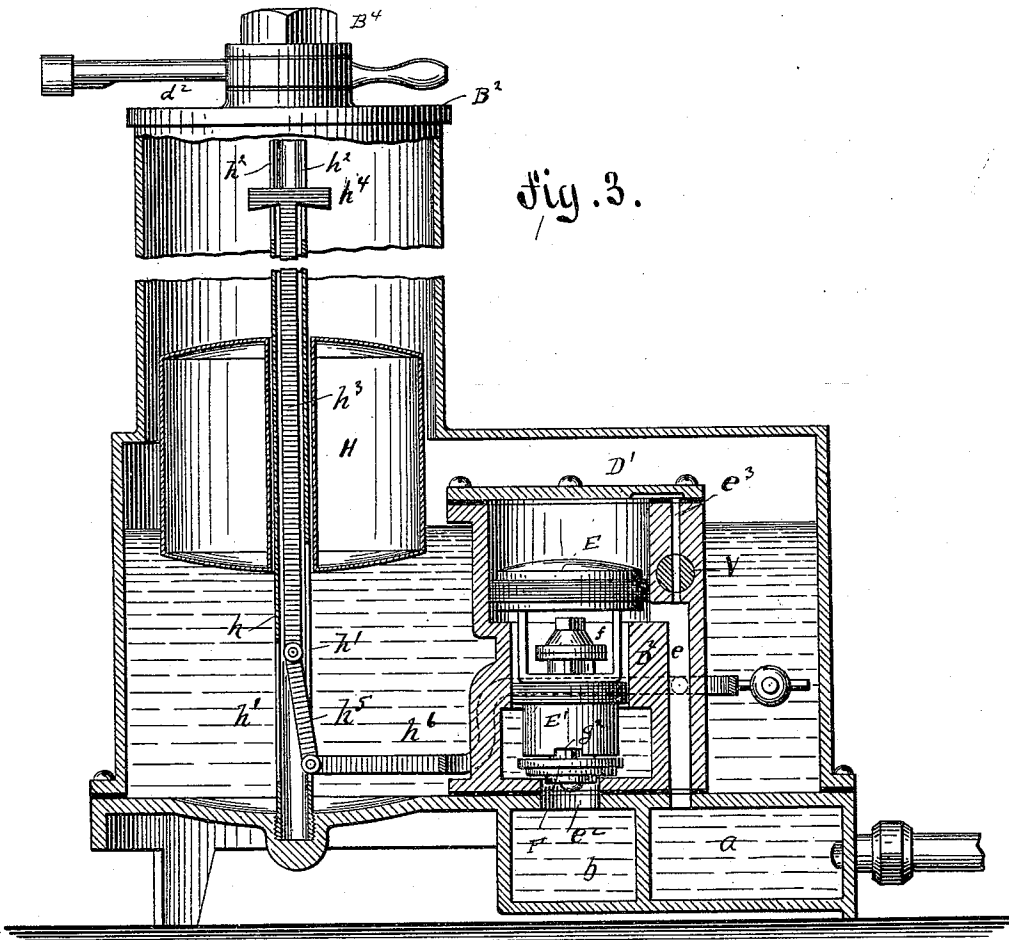

Fig. 3.

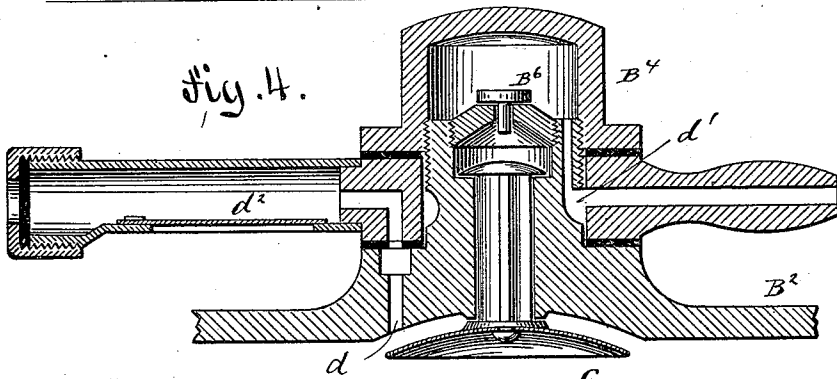
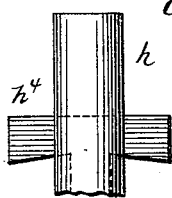

Fig. 4.

WITNESSES:

*J. N. Rosenbaum*  
*Witness*



INVENTOR

*Thomas Lieb*  
BY *Luppel & Paegauer*  
ATTORNEYS

T. LIEB.  
HYDRAULIC AIR PUMP.

No. 447,961.

Patented Mar. 10, 1891.

*Fig. 5.*

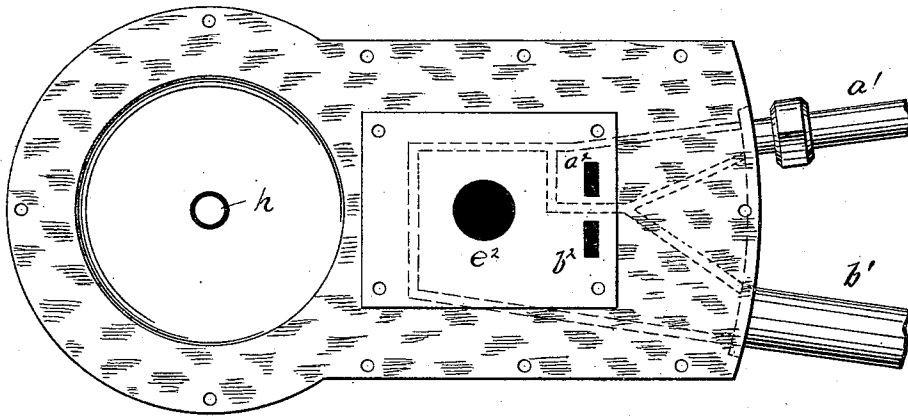

*Fig. 6.*

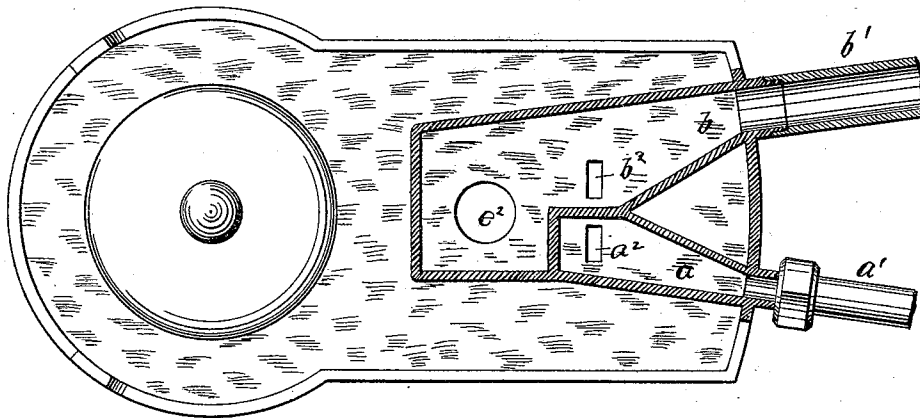

WITNESSES:

*A. Schuhl.*  
*Meinher*

INVENTOR

*Thomas Lieb*  
BY *Luyck & Paegauer*  
ATTORNEYS

T. LIEB.  
HYDRAULIC AIR PUMP.

No. 447,961.

Patented Mar. 10, 1891.

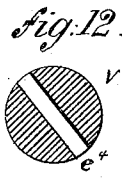
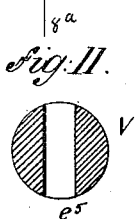
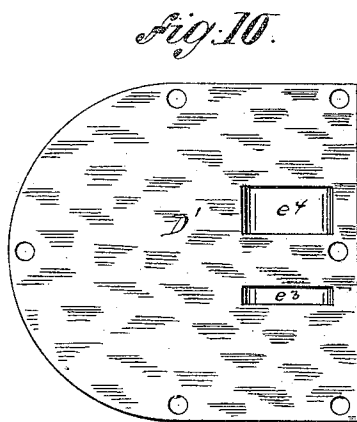
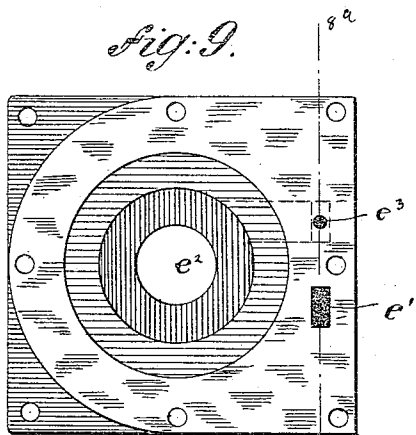
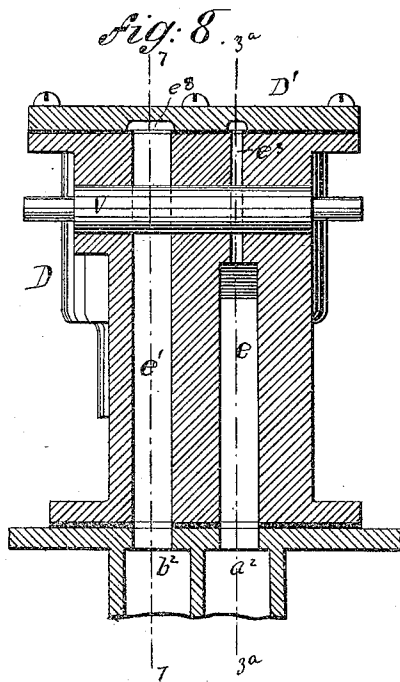
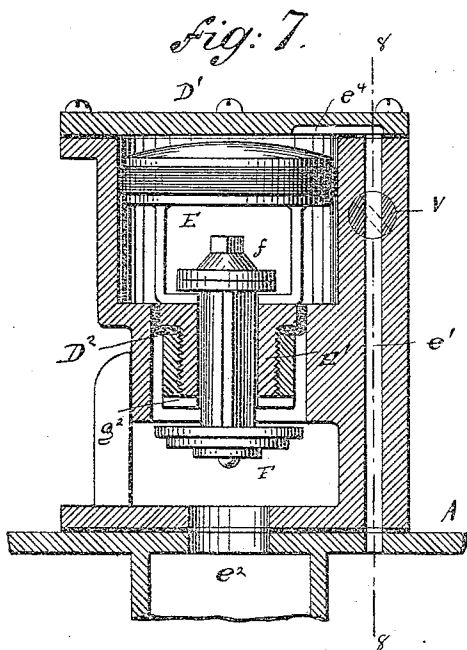

WITNESSES:  
A. Schehl.  
Meimken

INVENTOR  
Thomas Lieb  
BY  
Loupel, Buequier  
ATTORNEYS

# UNITED STATES PATENT OFFICE.

THOMAS LIEB, OF NEW YORK, N. Y.

## HYDRAULIC AIR-PUMP.

SPECIFICATION forming part of Letters Patent No. 447,961, dated March 10, 1891.

Application filed August 25, 1890. Serial No. 363,065. (No model.)

*To all whom it may concern:*

Be it known that I, THOMAS LIEB, of the city, county, and State of New York, a citizen of the United States, have invented certain new and useful Improvements in Hydraulic Air-Pumps, of which the following is a specification.

This invention has reference to an improved hydraulic air-pump of that class which is used for supplying a uniform pressure of air to a keg containing a liquid for the purpose of lifting the liquid to the place where the same is drawn off for sale; and the invention consists of a hydraulic air-pump in which the air is automatically compressed, the water being supplied through an induction-port to a piston at the interior of the casing, so that said piston raises the valve that closes the main outlet, so as to permit the outflow of the water from the casing. When the water is drawn off, the valve closes the main outlet, but keeps open the supply-openings, so as to refill the casing and operate thereby a float that is guided in a compression-cylinder extending from the top of the casing. The float on rising engages a shifting-lever mechanism that operates an oscillating valve that opens or closes the supply-channels of the cylinder, so as to shift said valve and produce the opening of the main outlet and the outflow of the water in the pump-casing. The air that is compressed in the compression-cylinder is drawn in through an inlet-valve at the upper part of the same during the downward motion of the float and forced through a connecting-tube to the place of use during the rising motion of the float. A cup-shaped protector is arranged in the top part of the compression-cylinder and serves to close the compressed-air-outlet openings in case the actuating mechanism of the pump should get out of order, so as to prevent the flow of water into the compressed-air-outlet pipe.

The invention consists, further, of certain details of construction and combination of parts, as will be fully described hereinafter, and finally be pointed out in the claims.

In the accompanying drawings, Figure 1 represents a side elevation of my improved hydraulic air-pump, showing a portion of the pump broken off so as to show the interior

construction of the pump. Fig. 2 is a horizontal section on the line 2 2, Fig. 1. Fig. 3 is a vertical longitudinal section on the line 3 3, Fig. 2, and 3<sup>a</sup> 3<sup>a</sup>, Fig. 8, parts being broken out. Fig. 4 is a detail vertical section through the air inlet and outlet tubes at the top part of the compression-chamber, said figure being drawn on a larger scale. Fig. 5 is a top view of the bottom plate of the casing with the induction and eduction ports. Fig. 6 is a bottom view of said bottom plate showing the water supply and discharge channels in horizontal section. Figs. 7 and 8 are detail vertical sections, respectively, on lines 7 7, Fig. 8, and 8 8, Fig. 7, and 8<sup>a</sup> 8<sup>a</sup>, Fig. 9, of the valve-piston and the cylinder. Fig. 9 is a top view of the valve-cylinder with the top plate removed. Fig. 10 is a bottom view of the top plate of said cylinder, and Figs. 11 and 12 are vertical transverse sections through the oscillating valve by which water is admitted from the main to the top of the cylinder and released from the top of the cylinder to the exhaust.

Similar letters of reference indicate corresponding parts.

Referring to the drawings, A represents the bottom plate of my improved hydraulic air-pump and B the casing of the same, which is tightly secured to the bottom plate by the intermediate packing and fastening screws. The bottom plate is cast integral with the induction and eduction channels *a* and *b*, said channels communicating, respectively, with the water supply and discharge pipe *a'* *b'*. From the upper part of the casing extends a compression-cylinder *B'*, which is closed by a top *B<sup>2</sup>* that is provided with air inlet and outlet channels *d d'*. The air-channel *d* communicates by an inwardly-opening valve *d<sup>2</sup>* with the atmosphere, while the outlet-channel *d'* communicates by a tube with the vessel to which the compressed air is to be conducted.

From the top part *B<sup>2</sup>* is guided the spindle of a cup-shaped protector *C*, which forms a safety device for preventing the water from passing to the compressed-air-outlet channel, in case the air-pump for some reason or other does not perform its regular function. In this case the water rising in the compression-cylinder lifts the protector which closes

thereby the compressed-air-outlet openings, so as to prevent the water from passing into or through said compressed-air-outlet channel. A tightly-applied screw-cap  $B^4$  is screwed to the central portion of the top part  $B^2$ .

The water induction and eduction channels communicate with the interior of the pump-casing by ports  $a^2$  and  $b^2$  in the bottom plate A, as shown clearly in Fig. 6. Above said ports is arranged the cylinder D, which is screwed securely to the bottom plate A. The cylinder is closed at the top by a top plate  $D'$ , which is screwed to the top part of the cylinder D. In the cylinder is guided a piston  $E E'$ , which is formed of a larger piston E, which is guided in the larger upper portion of the cylinder D and of a smaller piston  $E'$ , which is guided in the smaller lower portion  $D^2$  of the cylinder D, as shown in Fig. 3. Both pistons are provided with packing-rings, so as to fit in their respective parts of the cylinders in which they are moved up and down. In the lower piston  $E'$  is guided a stem of the valve F, which serves to close the main outlet  $e^2$  when the pistons  $E E'$  are in their lowermost positions in the cylinder D. When the pistons  $E E'$  are in their uppermost positions, the lower cylinder E engages the enlarged head  $f$  of the stem of the valve F and lifts the same, so as to open the main outlet  $e^2$  and permit the water in the pump-chamber to pass through the eduction-channel  $b$  and discharge-pipe  $b'$  to the outside. The cylinder D is provided in its wall with two vertical channels  $e e'$ , which communicate, respectively, with the induction and eduction ports  $a^2 b^2$ , as shown clearly in Figs. 3, 7, and 8. The channel  $e$  terminates at the interior of the upper part of the cylinder D below the piston E, and has an extension-channel  $e^3$  of smaller size, which communicates with recesses in the top  $D'$  and with that part of the cylinder above the piston E. The second channel  $e'$  extends throughout the whole length of the wall of the cylinder D, and communicates by a recess  $e^8$ , Fig. 7, in the under side of the top  $D'$  with the upper portion of the cylinder D so as to permit the water to escape from the space above the piston E when said piston is forced upward by water under pressure acting from below. The cylindrical valve V, which is preferably made of hard rubber or other suitable material, extends transversely through the supply-channel  $e$  and the exhaust-channel  $e^3$  in the cylinder D, and is provided with openings  $e^4$  and  $e^5$ , which are arranged at an angle to each other, as shown clearly in Figs. 11 and 12, and which correspond, respectively, with channels  $e$  and  $e^3$ , according to the position of the axially-turning valve D.

The bottom part of the lower piston  $E'$  is provided with recesses that form openings which communicate with openings  $g^2$  around the stem of the valve F, so that when the latter is in its lowermost position, so as to close the main outlet  $e^2$ , the water can pass from

the induction-channel  $e$  into the upper part of the cylinder D, and from the same along the stem of the valve F, and through the openings  $g^2$ , at the lower part of the piston  $E'$ , to the interior of the casing B. In the lowermost position of the piston-valve F the valve-casing B is thereby gradually filled with water supplied from the water-supply pipe  $a'$ . By the rising of the water in the casing B a float H, which is guided on a tubular spindle  $h$ , is lifted. The tube  $h$  is firmly attached to the bottom plate A and extended in upward direction centrally to the compression-chamber  $B'$ , as shown in Figs. 1 and 3. The tube is provided with longitudinal slots  $h'$  at its lower part and with slots  $h^2$  at its upper end. A slide-rod  $h^3$  is guided in the interior of the tube  $h$ , said guide-rod being provided with a T-shaped head  $h^4$ , that slides in the slots  $h^2$  at the upper end of the tube  $h$ . The lower end of the slide-rod  $h^3$  is connected by a pivot-link  $h^5$ , which extends through the longitudinal slots  $h'$  of the tube  $h$ , with a forked and weighted lever  $h^6$ , that is fulcrumed at diametrically-opposite points of the cylinder D, and connected by an arm  $h^7$  and a pivot-link  $h^8$  with a fixed arm  $h^9$ , that is clamped to the outer end of the oscillating-valve V, as shown clearly in Fig. 1.

As the water gradually rises in the casing B the float H is lifted so as to move along the tube  $h$  in the air-compression chamber  $B'$  and compresses the air therein and forces it through the grooves in the stem of the protector C, the cap  $B^4$ , the outlet-channel  $d'$ , and the connecting-tube to the place where it is to be used. The compressed air raises the valve  $p^6$  in passing out in the manner described. When the float H arrived at its uppermost position in the compression-chamber  $B'$ , it abuts against the T-shaped head  $h^4$  of the slide-rod  $h^3$  and lifts the same, thereby causing the lifting of the fulcrumed lever  $h^6$  and the shifting or oscillating of the valve V on its axis, so that the opening  $e^5$  in the same is moved in line with the outlet-channel  $e'$ , communicating with the top of the cylinder D, while the opening  $e^4$  of said valve is moved out of line with the upper part  $e^3$  of the supply-channel  $e$ . The water now enters the cylinder D below the piston E and forces the same upward, thereby raising the valve F, whereby the main outlet  $e^2$  is opened, thus permitting the entire body of water in the casing B to pass out through the main outlet  $e^2$  and the discharge-tube  $b$ . The pistons  $E E'$  and valve F are held in this raised position until all the water has passed out of the casing B. During the upward motion of the pistons  $E E'$  the head  $f$  of the valve F closes the central opening of the piston  $E'$ , and thereby prevents the water from passing along the stem of the same to the interior of the chamber B. As the level of the water gradually lowers in the pump-casing the float H moves in downward direction on the tube  $h$  until it strikes against the lever  $h^6$  and pro-

duces the lowering of the same, whereby the valve V is shifted, and thereby the opening  $e^4$  of the same brought in line with the supply-channel  $e$ , so that the water can pass through the channel  $e$   $e^3$  into the upper part of the cylinder D above the piston E and move the same in downward direction against the pressure of the water in the space below the same, which can be accomplished because the pressure of the water is greater on the larger piston E than on the smaller piston E'. By the downward motion of the pistons E and E' the valve F is tightly pressed on the main outlet  $b^2$  and the communication between the interior of the cylinder D below the piston E' along the stem of the valve F to the interior of the casing B re-established, so that the latter is filled again with water. This produces the raising of the float and the compression of the air in the compression-chamber until the float strikes against the T-shaped head of the shifting-rod and produces the shifting of the valve V and the opening of the main outlet  $e^2$ , and so on alternately, as the play of the pistons and valves are automatically kept up by the pressure of the water and the action of a float on the shifting mechanism. The float produces by the rise or fall of the water the shifting of the oscillating valve V, and thereby the upward or downward motion of the pistons EE', and the opening or closing of the main outlet. Whenever a sufficient body of air under pressure is supplied, so as to be counterbalanced, the operation of the pump is temporarily interrupted. As soon as the pressure of the air in the receptacle is diminished the air-pump begins its operation, so as to supply compressed air until equilibrium is established between the pressure in the receptacle and the pressure in the casing B. In this manner an effective and reliably-working hydraulic air-pump is supplied by which the water-pressure in the supply-main is utilized for compressing air.

Having thus described my invention, I claim as new and desire to secure by Letters Patent—

1. The combination, with a casing having

a compression-chamber and a water induction and eduction channel, of a cylinder in said casing, pistons of different areas guided in said cylinder, a discharge-valve guided in the lower piston, a supply-channel extending from the induction-channel above and below the upper piston, an outlet-channel extending from the main eduction-channel to the box of the cylinder, a float in the compression-chamber, a shifting mechanism operated by said float and connected with the oscillating valve, so as to produce the raising or lowering of the pistons and the opening or closing of the eduction-port by the discharge-valve, substantially as set forth.

2. In a hydraulic pump, the combination, with a cylinder, of two united pistons, a sliding valve in the lower piston, an inlet-channel and an outlet-channel for conducting water into and out of the cylinder, respectively, and a single oscillating valve controlling both inlet and outlet channels, and means for automatically shifting this oscillating valve, substantially as set forth.

3. In a hydraulic pump, the combination of a cylinder having a bottom outlet, two connected pack-pistons in said cylinder, a sliding valve-stem in the lower piston, a valve on the lower end of said stem for closing the bottom outlet, a valve-head on the upper end of the stem, and means for automatically reversing the movement of the united pistons, substantially as set forth.

4. In a hydraulic pump, the combination of a cylinder D, having the bottom outlet  $e^2$ , the inlet-channels  $e$   $e^3$ , the outlet-channel  $e'$ , the oscillating valve B, having the openings  $e^4$  and  $e^5$ , means for automatically shifting said valve, the united pistons E E' in the cylinder D, the valve F in the piston E', and the valve-head  $f'$  on the upper end of the stem of said valve F, substantially as set forth.

In testimony that I claim the foregoing as my invention I have signed my name in presence of two subscribing witnesses.

THOMAS LIEB.

Witnesses:

OSCAR F. GUNZ,

W. REIMHERR.