

## (12) 按照专利合作条约所公布的国际申请

(19) 世界知识产权组织  
国际局

(43) 国际公布日  
2019年6月20日 (20.06.2019)



(10) 国际公布号  
**WO 2019/114625 A1**

- (51) 国际专利分类号:  
*F04B 39/00* (2006.01) *F24F 13/24* (2006.01)
- (21) 国际申请号: PCT/CN2018/119773
- (22) 国际申请日: 2018年12月7日 (07.12.2018)
- (25) 申请语言: 中文
- (26) 公布语言: 中文
- (30) 优先权:  
201711311262.X 2017年12月11日 (11.12.2017) CN
- (71) 申请人: 青岛海尔股份有限公司(QINGDAO HAIER CO., LTD.) [CN/CN]; 中国山东省青岛市崂山区海尔路1号海尔工业园, Shandong 266101 (CN)。
- (72) 发明人: 杨春(YANG, Chun); 中国山东省青岛市崂山区海尔路1号海尔工业园, Shandong 266101 (CN)。 陈建全(CHEN, Jianquan); 中国山东省青岛市崂山区海尔路1号海尔工业园, Shandong 266101 (CN)。 张浩(ZHANG, Hao); 中国山东省青岛市崂山区海尔路1号海尔工业园, Shandong 266101 (CN)。 夏恩品(XIA, Enpin); 中国山东省青岛市崂山区海尔路1号海尔工业园, Shandong 266101 (CN)。
- (74) 代理人: 苏州威世朋知识产权代理事务所(普通合伙)(SUZHOU WISPRO INTELLECTUAL PROPERTY AGENCY); 中国江苏省苏州市工业园区星湖街999号99幢506室谢丽君, Jiangsu 215028 (CN)。
- (81) 指定国(除另有指明, 要求每一种可提供的国家保护): AE, AG, AL, AM, AO, AT, AU, AZ, BA, BB, BG, BH, BN, BR, BW, BY, BZ, CA, CH, CL, CN, CO, CR, CU, CZ, DE, DJ, DK, DM, DO, DZ, EC, EE, EG, ES, FI, GB, GD, GE, GH, GM, GT, HN, HR, HU, ID, IL, IN, IR, IS, JO, JP, KE, KG, KH, KN, KP, KR, KW, KZ, LA, LC, LK, LR, LS, LU, LY, MA, MD, ME, MG, MK, MN, MW, MX, MY, MZ, NA, NG, NI, NO, NZ, OM, PA, PE, PG, PH, PL, PT, QA, RO, RS, RU, RW, SA, SC, SD, SE, SG, SK, SL, SM, ST, SV, SY, TH, TJ, TM, TN, TR, TT, TZ, UA, UG, US, UZ, VC, VN, ZA, ZM, ZW。

(54) Title: VACUUM PUMP VENT PIPE SILENCER AND REFRIGERATOR HAVING SAME

(54) 发明名称: 真空泵排气管消音器及冰箱



图 12

(57) Abstract: Provided is a silencer (300), comprising a hollow cavity jointly enclosed by a first bottom face (310), a second bottom face (320) and a side wall (330), wherein the side wall (330) is connected to the first bottom face (310) and the second bottom face (320); one end of the silencer (300) is provided with an air inlet (340), and the other opposite end is provided with an air outlet (350); the cavity is divided into a plurality of chambers in an axial direction, the chambers comprising a first chamber (361) adjacent to the first bottom face (310), a second chamber (363) adjacent to the second bottom face (320), and a middle chamber (362) located between the first chamber (361) and the second chamber (363); the air inlet (340) is in air communication with the middle chamber (362); the middle chamber (362) is in air communication with the second chamber (363); the first chamber (361) is in air communication with the second chamber (363); and the air outlet (350) is in air communication with the first chamber (361). The silencer (300) further comprises a first guide pipe (371), a second guide pipe (372), a third guide pipe (373) and a fourth guide pipe (374), wherein the air inlet (340) is in communication with the middle chamber (362) via the first guide pipe (371), the middle chamber (362) is in communication with the second chamber (363) via the second guide pipe (372), the first chamber (361) is in communication with the second chamber (363) via the third guide pipe (373), and the first chamber (361) is in communication with the air outlet (350) via the fourth guide pipe (374); and the first guide pipe (371), the second guide pipe (372), the third guide pipe (373) and the fourth guide pipe (374) are configured to be successively arranged in the direction of an air path.

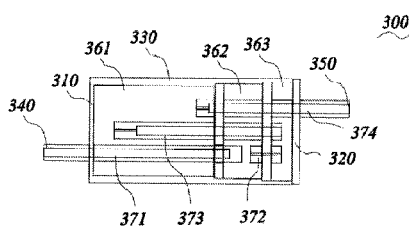

(84) 指定国(除另有指明, 要求每一种可提供的地区保护): ARIPO (BW, GH, GM, KE, LR, LS, MW, MZ, NA, RW, SD, SL, ST, SZ, TZ, UG, ZM, ZW), 欧亚 (AM, AZ, BY, KG, KZ, RU, TJ, TM), 欧洲 (AL, AT, BE, BG, CH, CY, CZ, DE, DK, EE, ES, FI, FR, GB, GR, HR, HU, IE, IS, IT, LT, LU, LV, MC, MK, MT, NL, NO, PL, PT, RO, RS, SE, SI, SK, SM, TR), OAPI (BF, BJ, CF, CG, CI, CM, GA, GN, GQ, GW, KM, ML, MR, NE, SN, TD, TG)。

本国际公布:

— 包括国际检索报告(条约第21条(3))。

(57) 摘要: 一种消音器(300), 包括由第一底面(310)、第二底面(320)及侧壁(330)共同围合形成的中空腔体, 侧壁(330)连接第一底面(310)及第二底面(320), 消音器(300)一端配置进气口(340), 相对另一端配置出气口(350), 腔体沿轴向被分隔为若干腔室, 腔室包括与第一底面(310)相邻的第一腔室(361)、与第二底面(320)相邻的第二腔室(363)及位于第一腔室(361)与第二腔室(363)之间的中间腔室(362), 进气口(340)与中间腔室(362)气体导通, 中间腔室(362)与第二腔室(363)气体导通, 第一腔室(361)与第二腔室(363)气体导通, 出气口(350)与第一腔室(361)气体导通。消音器(300)还包括第一导管(371)、第二导管(372)、第三导管(373)及第四导管(374), 第一导管(371)导通进气口(340)与中间腔室(362), 第二导管(372)导通中间腔室(362)与第二腔室(363), 第三导管(373)导通第一腔室(361)与第二腔室(363), 第四导管(374)导通第一腔室(361)与出气口(350)。第一导管(371)、第二导管(372)、第三导管(373)和第四导管(374)被配置为沿气路方向依次排布。

# **VACUUM PUMP EXHAUST PIPE MUFFLER AND REFRIGERATOR HAVING SAME**

[0001] This application claims the priority of Chinese patent application,  
5 the filing date of which is December 11, 2017, the application number is  
201711311262.X, and the title of invention is "vacuum pump exhaust pipe  
muffler and refrigerator having same", the entire contents of which are  
incorporated herein by reference in its entirety.

## **TECHNICAL FIELD**

10 [0002] The present invention relates to the technical field of noise  
reduction of refrigeration apparatus, and specifically to a muffler for reducing  
noise of a vacuum pump.

## **BACKGROUND**

[0003] Freshness of food in a refrigerator is closely related to temperature,  
15 humidity and gas environment, wherein oxygen is an important factor causing  
spoilage, deterioration and bacteria multiplication of the food. A preservation  
period of the food may be significantly prolonged by pumping oxygen in the  
compartment to control a nitrogen-to-oxygen ratio of the refrigerator.

[0004] Oxygen may be pumped out from a specific space via a vacuum  
20 pump, and discharged outside the refrigerator. However, when gas, as a medium  
for conducting a sound, conducts noise in the refrigerator to an external space of  
the refrigerator during the discharge, thereby causing noise interference.

## **SUMMARY**

25 [0005] An object of the present invention is to provide a muffler to solve  
the problem of noise output of a vacuum pump.

[0006] To achieve the object, the present invention provides a muffler  
including a hollow cavity enclosed by a first bottom surface, a second bottom  
surface and a side wall, the side wall connects the first bottom surface with the  
30 second bottom surface; an air inlet at one end of the muffler and an air outlet at  
the other end of the muffler; the cavity is divided into a plurality of chambers in  
an axial direction, the chambers include a first chamber adjacent to the first

bottom surface, a second chamber adjacent to the second bottom surface and an intermediate chamber located between the first chamber and the second chamber, the air inlet is in gas communication with the intermediate chamber, the intermediate chamber is in gas communication with the second chamber, the first chamber is in gas communication with the second chamber, and the air outlet is in gas communication with the first chamber.

**[0007]** A further improvement as an embodiment of the present invention, at least part of the chambers have different volumes.

**[0008]** A further improvement as an embodiment of the present invention, the muffler further includes a first duct, a second duct, a third duct and a fourth duct, the first duct is communicated with the air inlet and the intermediate chamber, the second duct is communicated with the intermediate chamber and the second cavity, the third duct is communicated with the first chamber and the second chamber, and the fourth duct is communicated with the first chamber and the air outlet.

**[0009]** A further improvement as an embodiment of the present invention, the first duct, the second duct, the third duct and the fourth duct are configured to be arranged in turn in an air path direction.

**[0010]** A further improvement as an embodiment of the present invention, there is at least one the intermediate chamber.

**[0011]** To achieve the object, the present invention provides a muffler including a housing, wherein the housing is enclosed to form a hollow cavity, an air inlet is arranged at a proximal end of the housing, an air outlet is arranged at a distal end of the housing, the cavity is divided into a plurality of chambers from the proximal end to the distal end, the chambers include a first chamber positioned relatively adjacent to the proximal end, a second chamber positioned relatively adjacent to the distal end and an intermediate chamber located between the first chamber and the second chamber, the air inlet is in gas communication with the intermediate chamber, the intermediate chamber is in gas communication with the second chamber, the first chamber is in gas communication with the second chamber, and the air outlet is in gas communication with the first chamber.

**[0012]** A further improvement as an embodiment of the present invention, at least part of the chamber have different volumes.

[0013] A further improvement as an embodiment of the present invention, the muffler further includes a first duct, a second duct, a third duct and a fourth duct, the first duct is communicated with the air inlet and the intermediate chamber, the second duct is communicated with the intermediate chamber and the second cavity, the third duct is communicated with the first chamber and the second chamber, and the fourth duct is communicated with the first chamber and the air outlet.

[0014] A further improvement as an embodiment of the present invention, the first duct, the second duct, the third duct and the fourth duct are configured to be arranged in turn in an air path direction.

[0015] To achieve the project, the present invention provides a refrigerator including a sealed box receiving a vacuum pump, wherein the refrigerator further includes the muffler as above, and the vacuum pump is connected with the muffler.

[0016] As compared with the prior art, a refrigerator vacuum pump muffler provided by the present invention realizes the attenuation of sound waves by the design with multiple cavities and cyclically-arranged ducts, reduces the sound energy, and prevents the noise of the vacuum pump and a box from being conducted outside the box.

20

**BRIEF DESCRIPTION OF THE DRAWINGS**

[0001] FIG. 1 is a schematic structural diagram of a sealed box according to an embodiment of the present invention;

[0002] FIG. 2 is a schematic diagram of components inside and outside a sealed box according to an embodiment of the present invention;

[0003] FIG. 3 is a top view of a sealed box according to an embodiment of the present invention;

[0004] FIG. 4 is an exploded schematic view of a sealed box according to an embodiment of the present invention;

[0005] FIG. 5 is a front view of a sealed box according to an embodiment of the present invention;

[0006] FIG. 6 is a top view of a seal in an embodiment of the present invention;

30

- [0007] FIG. 7 is a schematic structural diagram of a seal in an embodiment of the present invention;
- [0008] FIG. 8 is a top view of a lower sealing body in an embodiment of the present invention;
- 5 [0009] FIG. 9 is a schematic diagram of mounting an upper sealing body and a metal plate in an embodiment of the present invention;
- [0010] FIG. 10 is a schematic structural diagram of a lower sealing body in an embodiment of the present invention;
- [0011] FIG. 11 is an exploded view of FIG. 10;
- 10 [0012] FIG. 12 is a perspective view of a muffler in an embodiment of the present invention;
- [0013] FIG. 13 is a perspective view of a muffler in another embodiment of the present invention;
- [0014] FIG. 14 is a schematic structural diagram of a vacuum pump and a muffler in a further embodiment of the present invention;
- 15 [0015] FIG. 15 is a schematic structural diagram of a muffler in a further embodiment of the present invention;
- [0016] FIG. 16 is a perspective view of a muffler in a further embodiment of the present invention;
- 20 [0017] FIG. 17 is a schematic longitudinal sectional view of a muffler in a further embodiment of the present invention.

**DETAILED DESCRIPTION**

[0018] The present invention will be described in detail in conjunction with specific embodiments shown in the figures. However, these embodiments are not limited to the present invention. Variations in terms of structure, method or function made by those having ordinary skill in the art according to these embodiments are all included in the scope of the present invention.

[0019] Terms indicating positions and directions described in the present invention all take a vacuum pump as a reference. An end close to the vacuum pump is a proximal end, and an end away from the vacuum pump is a distal end.

[0020] Referring to FIG. 1 through FIG. 3, in an embodiment of the present invention, a vacuum pump 100 is received in a sealed box 200, and

communicated with ambient air through an air inlet pipe 210 and an air outlet pipe 220. A proximal end of the air inlet pipe 210 is communicated with an air intake line of the vacuum pump 100, and a distal end is communicated with a fresh-keeping space in the refrigerator compartment (not shown); a proximal end of the air outlet pipe 220 is communicated with an air exhaust line of the vacuum pump 100, and a distal end extends towards outside the sealed box 200. The sealed box 200 blocks air communication between the vacuum pump 100 and an installation environment, and achieves an effect of sound insulation. The fresh-keeping space may be either an independent compartment or a closed or semi-closed space located in a portion of the refrigerator compartment.

**[0021]** The sealed box 200 includes an upper sealing body 230 and a lower sealing body 240. The upper sealing body 230 includes a top wall and side walls which are integrally formed and jointly define a receiving cavity with a lower end opening. The lower sealing body 240 includes a bottom wall and side walls which are integrally formed and jointly define a receiving cavity with an upper end opening. The opening of the upper sealing body 230 and the opening of the lower sealing body 240 match each other, and snap fit each other to form a receiving space of the vacuum pump 100.

**[0022]** Preferably, the upper sealing body 230 and the lower sealing body 240 are made of plastic.

**[0023]** Referring to FIG. 4, a seal is provided between the upper sealing body 230 and the lower sealing body 240. A first groove is formed at a lower edge of the side walls of the upper sealing body 230, a second groove is formed at an upper edge of the side walls of the lower sealing body 240, and the first groove matches with the second groove to form a mounting groove for a gasket ring 250. In this way, the airtightness can be ensured after the upper sealing body 230 and the lower sealing body 240 are snap fitted, and sound can be prevented from being transmitted outside through a splicing gap of the sealed box 200. The gasket ring 250 is ring-shaped and has a circular cross-section. The gasket ring 250 is made of an elastic material, and has a mounting tension amount 2-5% when embedded in the mounting groove. When the upper sealing body 230 and the lower sealing body 240 are snap-fitted, a pressure is applied to the gasket ring 250 to form a 20-30% compression amount, thereby ensuring the sealing effect.

**[0024]** FIG. 4 and FIG. 5 show that a notch portion 251 is provided at

where the upper sealing body 230 and the lower sealing body 240 are engaged, and allows a wire connected to the vacuum pump 100 to pass through. In order to ensure the sealing performance of the sealed box 200, a snap-fittable sealing ring 253 is provided at the notch portion 251. The sealing ring 253 is made of an elastic material and integrally formed with the gasket ring 250.

5 [0025] Referring to FIG. 6 and FIG. 7, the sealing ring 253 is composed of two H-shaped members that are flexibly connected, and the H-shaped members can be snap-fitted to each other to form a mounted state that cooperates with the notch portion 251. The H-shaped member has a first arm 2531 and a second arm 10 2532 parallel to each other, and a connecting portion 2533 connecting the first arm 2531 with the second arm 2532. The first arm 2531 and the second arm 2532 can cooperate to clamp the side wall of the box body at the edge of the notch portion 251 therebetween to prevent the sealing ring 253 from falling off from the notch portion 251. The connecting portion 2533 passes through the notch 15 portion and connects the first arm 2531 with the second arm 2532. The connecting portion 2533 has a recessed arc-shaped surface. When the H-shaped members are snap-fitted to each other, their arc-shaped surfaces together enclose to form a hollow cavity to allow the wire to pass therethrough.

[0026] In a case where a plurality of wires passes through the notch 20 portion 251, if the wires as a whole pass through the notch portion 251, since the cross section of the wires is circular, a gap formed between the wires will reduce the sealing performance. In this case, the arc-shaped surface of the connecting portion 2533 may be wavy (not shown) to form a plurality of independent hollow cavities in the mounted state to better seal the wires with a circular cross-section.

25 [0027] Referring to FIG. 8, a plurality of metal plates 260 are disposed in the sealed box 200, and the metal plates 260 are disposed between the vacuum pump 100 and the side walls of the sealed box 200. Since the metal plates 260 have a high density, they can block transmission of sound therethrough and achieve an effect of sound insulation and noise reduction.

30 [0028] Preferably, the metal plate 260 is an aluminum plate, a steel plate, or a galvanized plate.

[0029] Referring to FIG. 8 and FIG. 9, in an embodiment of the present invention, there are two metal plates 260 which are respectively attached to two opposite walls of the sealed box 200. The lower sealing body 240 and the upper

sealing body 230 are respectively provided with a limiting structure to secure the metal plates 260a and 260b.

**[0030]** FIG. 8 shows that the bottom wall of the lower sealing body 240 is provided with a first rib 242 being parallel to a side wall 241 and spaced apart a distance  $d$ , and a second rib 244 being parallel to a side wall 243 and spaced apart a distance  $D$ , wherein the side wall 241 and the side wall 243 are opposed,  $d$  is the thickness of the metal plate 260a, and  $D$  is the thickness of the metal plate 260b. The spacing between the first rib 242 and the side wall 241 forms a limiting groove that limits the horizontal displacement of the metal plate 260a, and the spacing between the second rib 244 and the side wall 243 forms a limiting groove that limits the horizontal displacement of the metal plate 260b.

**[0031]** Referring to FIG. 8 and FIG. 10, the lower sealing body 240 is further provided with a plurality of guide grooves 245. The guide grooves 245 extend in a vertical direction and the extension direction is consistent with the insertion direction installing the metal plates 260. The guide grooves 245 guide the metal plates 260 to be mounted to preset positions.

**[0032]** FIG. 9 shows that the upper sealing body 230 is provided with a plurality of resisting members 231. When the upper sealing body 230 and the lower sealing body 240 are snap-fitted, the resisting member 231 againsts the top of the metal plate 260. A stepped portion 2311 is provided at an end of the resisting member 231 which is in contact with the metal plate 260. The stepped portion 2311 cooperates with the side walls of the upper sealing body 230 to form an inverted U-shaped space to accommodate the top of the metal plate 260. The top surface of the stepped portion 2311 againsts the top surface of the metal plate 260 and limits the displacement of the metal plate 260 in the vertical direction. The sides of the stepped portion abut against the sides of the metal plate 260 and limit the displacement of the metal plate 260 in the horizontal direction.

**[0033]** The metal plate 260 is disposed close to the side wall of the sealed box 200. The vibration of the vacuum pump 100 might cause resonance of the metal plate 260 to form new noise which is conducted externally through the walls of the sealed box 200. The above limiting structures strictly limit the position of the metal plates 260 to avoid resonating and generating noise.

**[0034]** In an embodiment of the present invention, a notch portion 246 is

disposed on one of the upper sealing body 230 and lower sealing body 240, or on an engagement portion of the upper sealing body 230 and lower sealing body 240, to allow an air pipe assembly to pass therethrough.

5 [0035] FIG. 10 and FIG. 11 exemplarily show a case where the notch portion 246 is provided on the lower sealing body 240. The notch portion 246 is provided on a side wall of the lower sealing body 240 close to the upper edge, and a groove is provided at peripheral edge of the notch portion 246 to receive a sealing unit 270 to ensure the airtightness of the sealed box 200. The sealing unit 270 has an annular structure made of an elastic material.

10 [0036] The air pipe assembly includes an air inlet pipe 210, an air outlet pipe 220 and a base plate that are integrally formed. The air inlet pipe 210 and the air outlet pipe 220 are disposed through the base plate, and an outer edge of the base plate matches the shape of the notch portion 246. A groove is provided on the outer edge of the base plate to mate with a flange on the periphery of the notch portion 246, the mating of the groove and the flange can clamp and secure the base plate to the notch portion, and the sealing unit 270 is embedded at a gap between the groove and the flange.

[0037] The space of the cavity for receiving the vacuum pump 100 is compact and does not facilitate the operation of connecting and passing the air pipe line. It is possible to, by setting the air pipe assembly as an embedded mounting structure, conveniently embed and secure the air pipe assembly in the notch portion 246 after the air pipe assembly is connected with the vacuum pump 100, and then snap-fit the upper sealing body 230 and the lower sealing body 240 to complete the assembling.

25 [0038] The gas from the air outlet pipe 220 is exhausted to the outside of the refrigerator after being silenced. Referring to FIG. 1 and FIG. 12, in an embodiment of the present invention, the vacuum pump 100 is connected to the muffler 300 through the air outlet pipe 220. The muffler 300 includes a housing. The housing is enclosed jointly by a first bottom surface 310 at a proximal end, a second bottom surface 320 at a distal end and a side wall 330 connecting the first bottom surface 310 with the second bottom surface 320 to form a cylindrical hollow cavity. The muffler 300 is provided at the proximal end with an air inlet 340 connected to the air outlet pipe 220, and provided with an air outlet 350 at the distal end. The interior of the cavity is divided into several chambers in an

axial direction, the axial direction is the direction from the air inlet 340 to the air outlet 350, and at least part of the chambers have different volumes to correspondingly remove sounds at different frequency bands. Exemplarily, the volumes of respective chambers gradually decrease in the axial direction.

5 **[0039]** Preferably, there are three chambers, which are a first chamber 361, an intermediate chamber 362 and a second chamber 363 in turn from the proximal end to the distal end. The first chamber 361 is adjacent to the first bottom surface 310, the second chamber 363 is adjacent to the second bottom surface 320, and the intermediate cavity 362 is located between the first chamber  
10 361 and the second chamber 363. A first duct 371 is communicated with the air inlet 340 and the intermediate chamber 362, a second duct 372 is communicated with the intermediate chamber 362 and the second chamber 363, a third duct 373 is communicated with the first chamber 361 and the second chamber 363, and a fourth duct 374 is communicated with the first chamber 361 and the air outlet  
15 350.

**[0040]** There may be a plurality of intermediate chambers 362.

**[0041]** The shape of the housing of the muffler is not limited to a cylindrical shape, and may be set to a rectangular parallelepiped shape or an irregular shape.

20 **[0042]** Sound waves from the vacuum pump 100 pass through the first duct 371, the second duct 372, the third duct 373 and the fourth duct 374 in turn along with the airflow, and are reflected and refracted in turn in the intermediate chamber 362, the second chamber 363 and the first chamber 361 which have different volumes, and their energy is gradually dissipated. The muffling  
25 frequencies corresponding to the first chamber 361, the intermediate chamber 362 and the second chamber 363 are a low frequency, a medium frequency and a high frequency. In addition, the first duct 371, the second duct 372, the third duct 373 and the fourth duct 374 are provided with narrow inner diameters, so that partial energy of the sound waves is converted into thermal energy and dissipated  
30 when the sound waves pass through the ducts.

**[0043]** The muffler is arranged in a way that the sound waves travel in a path as long as possible in the muffler to reduce the energy and are reflected and refracted in different chambers, and a better muffling effect is achieved with a smaller muffler axial distance.

**[0044]** Referring to FIG. 13, in a further embodiment of the present invention, the muffler 400 includes a housing. The housing is enclosed jointly by a first bottom surface 410 at a proximal end, a second bottom surface 420 at a distal end, and a side wall 430 connecting the first bottom surface 410 with the second bottom surface 420 to form a cylindrical hollow cavity. A single chamber is formed in the cavity. The muffler 400 is provided with an air inlet 440 connected to the air outlet pipe 220 at the proximal end, and an air outlet 450 provided at the distal end. A first duct 471 is communicated with the air inlet 440 and the chamber, and a distal end of the first duct 471 is adjacent to the second bottom surface 420. A second duct 472 is communicated with the chamber and the air outlet 450, and a proximal end of the second duct 472 is adjacent to the first bottom surface 420.

**[0045]** The sound waves are reflected and refracted in the chamber, and the energy is gradually dissipated. The length of the first duct 471 and the second duct 472 is a quarter of a wavelength of a target audio to specifically eliminate the sound of the target audio. Preferably, a frequency of the target audio is 1000Hz.

**[0046]** The first duct 471 and the second duct 472 are provided with narrow inner diameters, so that partial energy of the sound waves is converted into thermal energy and dissipated when the sound waves pass through the ducts.

**[0047]** In the noise generated by the vacuum pump 100 and conducted via gas, the high-frequency noise cannot be heard by human ears, and the noise causing interference to the user is mainly low-frequency noise. The present embodiment may purposefully eliminate low-frequency noise and make the structure of the muffler simpler.

**[0048]** Referring to FIG. 14 and FIG. 15, in a further embodiment of the present invention, the muffler 500 is disposed inside the sealed box 200, and connects the exhaust line of the vacuum pump 100 and the air outlet pipe 220. The muffler 500 includes a housing, and the housing is enclosed to form a hollow cavity for refraction and reflection of sound waves. The hollow cavity includes a cylindrical chamber 510 and a rectangular parallelepiped chamber 520. One of bottom surfaces of the cylindrical chamber 510 is connected to one surface 521 of the rectangular parallelepiped chamber 520. The cylindrical chamber 510 is communicated with the interior of the rectangular parallelepiped chamber 520.

**[0049]** The diameter of the bottom surface of the cylindrical chamber 510 is less than or equal to a length of a side of a connecting surface 521 of the rectangular parallelepiped chamber 520.

5 **[0050]** The cylinder chamber 510 of the muffler 500 is provided with an air inlet 540 and an air outlet 550, and the air inlet 540 and the air outlet 550 are arranged at an angle so that the gas entering the hollow cavity reaches the outlet through reflected and refracted. During the process, the energy loses to achieve the muffling purpose.

10 **[0051]** Preferably, the air inlet 540 is disposed on the bottom surface 511 of the cylindrical chamber 510, and the air outlet 550 is disposed on a side of the cylindrical chamber 510.

**[0052]** The inner diameters of the air inlet 540 and the air outlet 550 are the same, so that the pressures at the two ports are balanced.

15 **[0053]** In the present embodiment, through the change of the shape of the hollow cavity, the sound waves are enabled to be reflected and refracted irregularly, and the energy is dissipated.

**[0054]** Referring to FIG. 16 and FIG. 17, in a further embodiment of the present invention, a muffler 600 includes a housing, and the housing is enclosed to form a hollow cavity. The muffler 600 is provided with an air inlet 640 at a proximal end and an air outlet 650 at a distal end. The air inlet 640 and the air outlet 650 are communicated by a duct 670 provided in the housing. The duct 670 and the housing form a sleeve structure. The duct 670 is filled with a medium to absorb the vibrational energy of the sound waves and weaken the sound intensity. Furthermore, the medium is silencer cotton.

25 **[0055]** A plurality of through holes 680 are defined on the side wall of the duct 670, so that the duct 670 can implement communication with the cavity. The through holes 680 are distributed spaced apart in a circumferential direction of the sidewall of the duct 670, that is, the duct 670 defines through holes in a plurality of directions.

30 **[0056]** Preferably, the housing is enclosed jointly by a first bottom surface 610 at a proximal end, a second bottom surface 620 at a distal end, and a side wall 630 connecting the first bottom surface 610 with the second bottom surface 620 to form a cylindrical hollow cavity. The first bottom surface 610 is provided with an air inlet 640, and the second bottom surface 620 is provided with an air

outlet 640.

**[0057]** Preferably, a diameter of the through holes is less than 1 mm.

**[0058]** Preferably, the cavity enclosed by the housing is divided into several chambers arranged from the proximal end to the distal end.

5 **[0059]** The sound waves from the vacuum pump 100 enter the duct 670 from the air inlet 640, and reach the air outlet 650 after being silenced by the medium. The sound waves at a specific frequency are attenuated and the sound intensity is weakened. During this process, partial sound waves, being diffracted by the through holes 680, enter the cavity, and are further attenuated after being  
10 refracted and reflected in the cavity.

**[0060]** The muffler is arranged in a way that the sound intensity is reduced through multiple channels by combining medium sound reduction with cavity sound reduction and be employing small holes to implement sound wave diffraction.

15 **[0061]** It should be understood that although the description is described according to the embodiments, not every embodiment only includes one independent technical solution, that such a description manner is only for the sake of clarity, that those skilled in the art should take the description as an integral part, and that the technical solutions in the embodiments may be suitably  
20 combined to form other embodiments understandable by those skilled in the art.

**[0062]** The detailed descriptions set forth above are merely specific illustrations of feasible embodiments of the present invention, and are not intended to limit the scope of protection of the present invention. All equivalent embodiments or modifications that do not depart from the art spirit of the present  
25 invention should fall within the scope of protection of the present invention.

## CLAIMS

1. A muffler including:

a hollow cavity enclosed by a first bottom surface, a second bottom surface and a side wall, the side wall connects the first bottom surface with the second  
5 bottom surface;

an air inlet at one end of the muffler and an air outlet at the other end of the muffler;

the cavity is divided into a plurality of chambers in an axial direction, the chambers include a first chamber adjacent to the first bottom surface, a second  
10 chamber adjacent to the second bottom surface and an intermediate chamber located between the first chamber and the second chamber, the air inlet is in gas communication with the intermediate chamber, the intermediate chamber is in gas communication with the second chamber, the first chamber is in gas communication with the second chamber, and the air outlet is in gas  
15 communication with the first chamber.

2. The muffler according to claim 1, wherein at least part of the chambers have different volumes.

3. The muffler according to claim 1, wherein further including a first duct, a  
20 second duct, a third duct and a fourth duct, the first duct is communicated with the air inlet and the intermediate chamber, the second duct is communicated with the intermediate chamber and the second cavity, the third duct is communicated with the first chamber and the second chamber, and the fourth duct is  
25 communicated with the first chamber and the air outlet.

4. The muffler according to claim 3, wherein the first duct, the second duct, the third duct and the fourth duct are arranged in turn in an air path direction.

5. The muffler according to claim 1, wherein there is at least one the  
30 intermediate chamber.

6. A muffler including a housing, wherein the housing is enclosed to form a hollow cavity, an air inlet is arranged at a proximal end of the housing, an air

outlet is arranged at a distal end of the housing, the cavity is divided into a plurality of chambers from the proximal end to the distal end, the chambers include a first chamber positioned relatively adjacent to the proximal end, a second chamber positioned relatively adjacent to the distal end and an intermediate chamber located between the first chamber and the second chamber, the air inlet is in gas communication with the intermediate chamber, the intermediate chamber is in gas communication with the second chamber, the first chamber is in gas communication with the second chamber, and the air outlet is in gas communication with the first chamber.

10

7. The muffler according to claim 6, wherein at least part of the chambers have different volumes.

8. The muffler according to claim 6, wherein further including a first duct, a second duct, a third duct and a fourth duct, the first duct is communicated with the air inlet and the intermediate chamber, the second duct is communicated with the intermediate chamber and the second cavity, the third duct is communicated with the first chamber and the second chamber, and the fourth duct is communicated with the first chamber and the air outlet.

20

9. The muffler according to claim 3, wherein the first duct, the second duct, the third duct and the fourth duct are arranged in turn in an air path direction.

10. A refrigerator including a sealed box receiving a vacuum pump, wherein the refrigerator further including the muffler according to claim 1, and the vacuum pump is connected with the muffler.

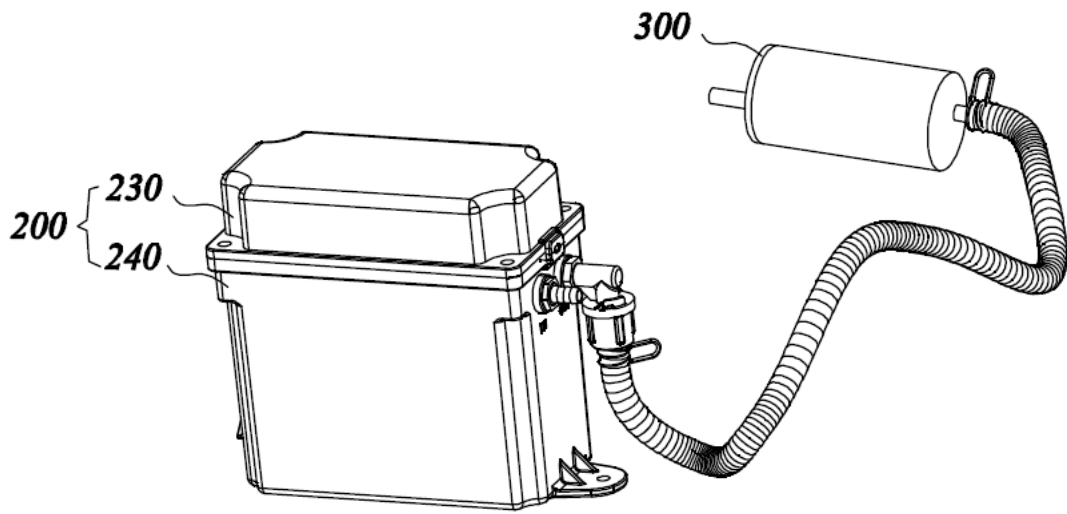

FIG. 1

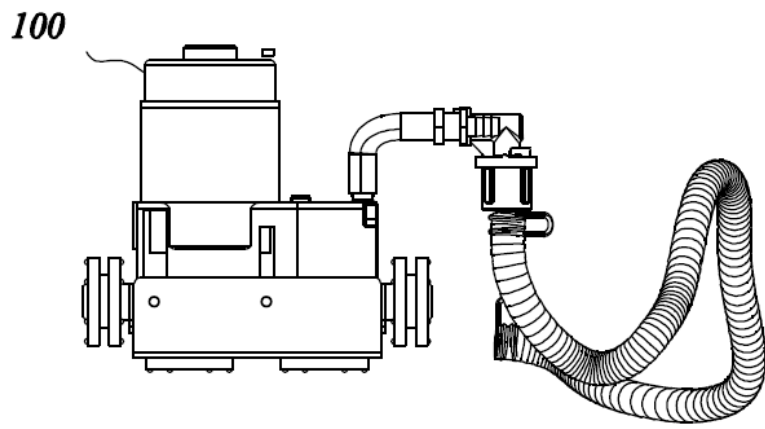

FIG. 2

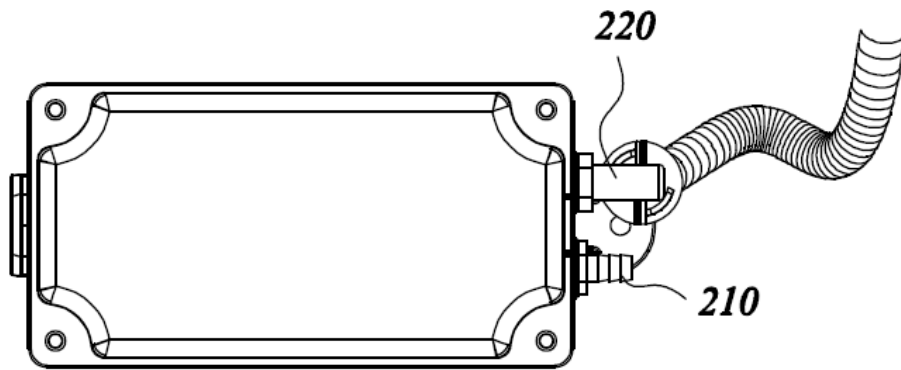

FIG. 3

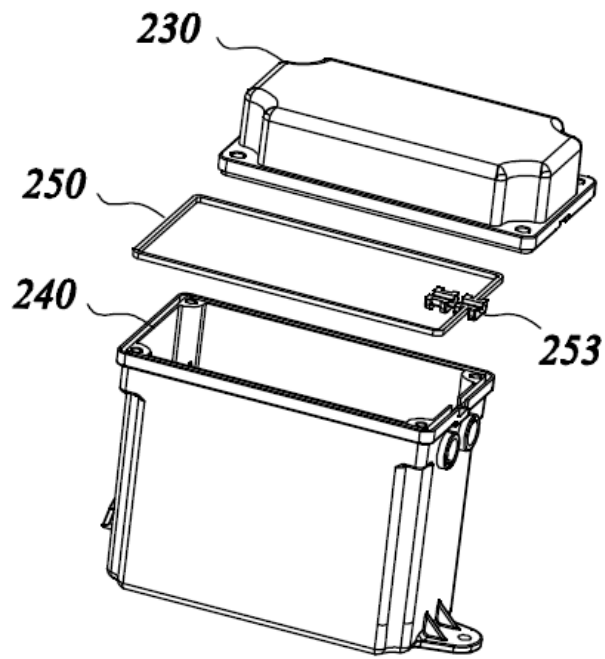

FIG. 4

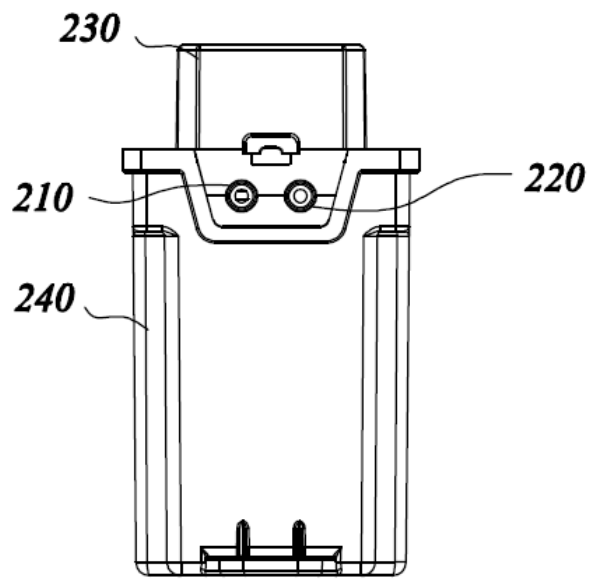

FIG. 5

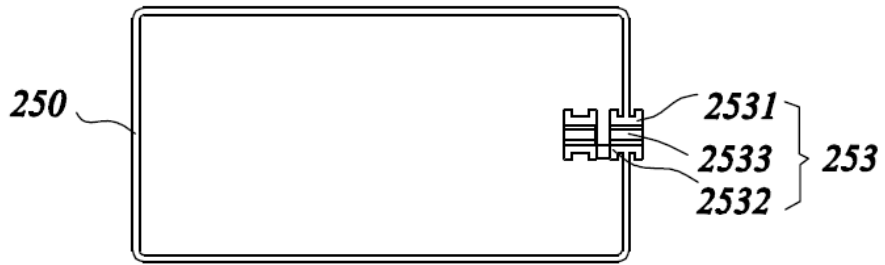

FIG. 6

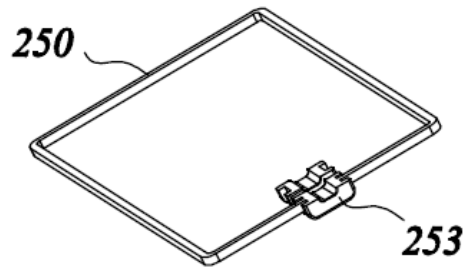

FIG. 7

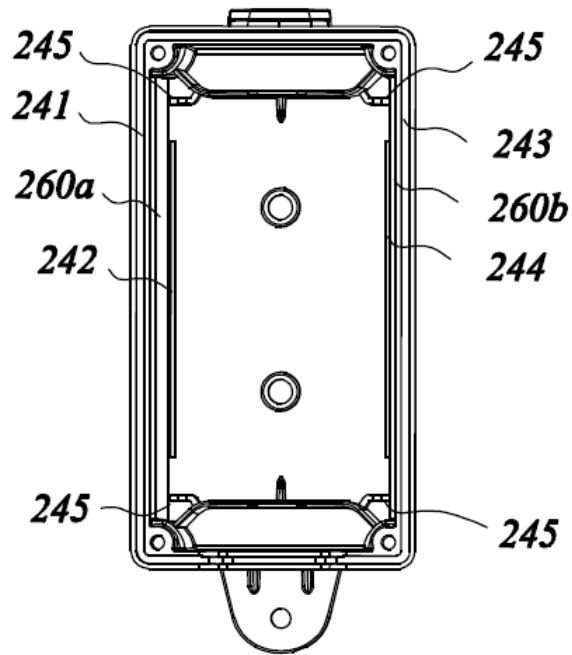

FIG. 8

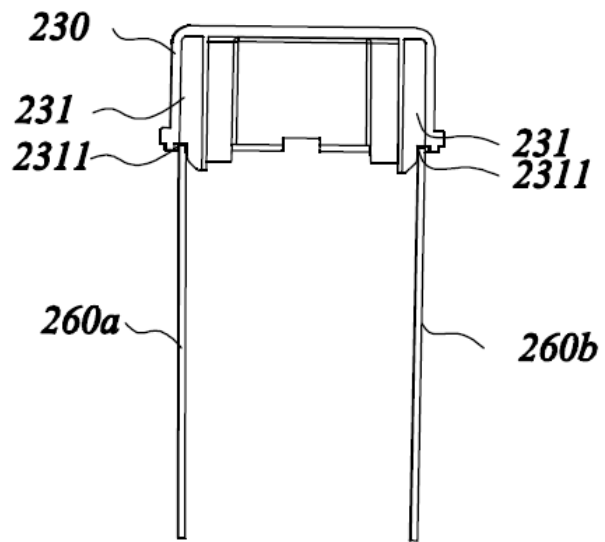

FIG. 9

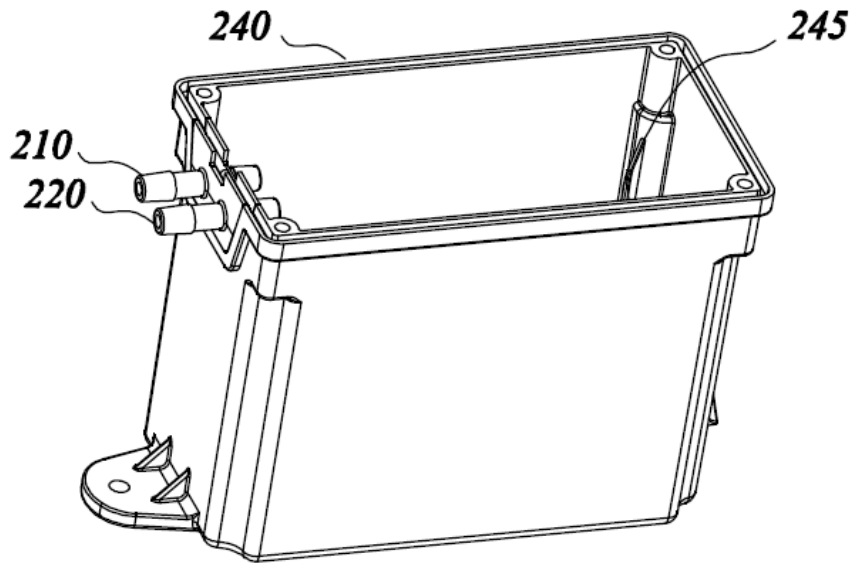

FIG.10

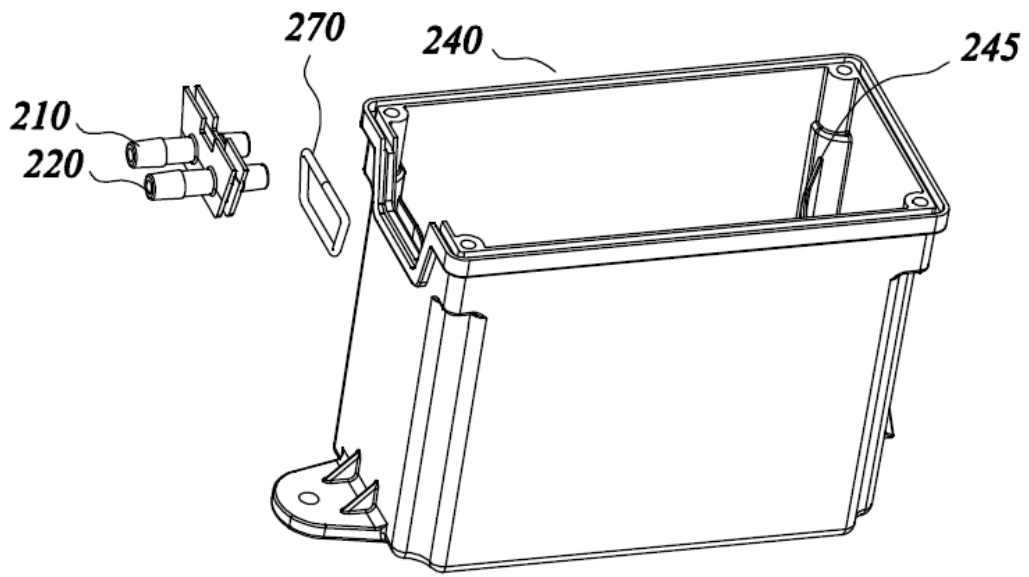

FIG.11

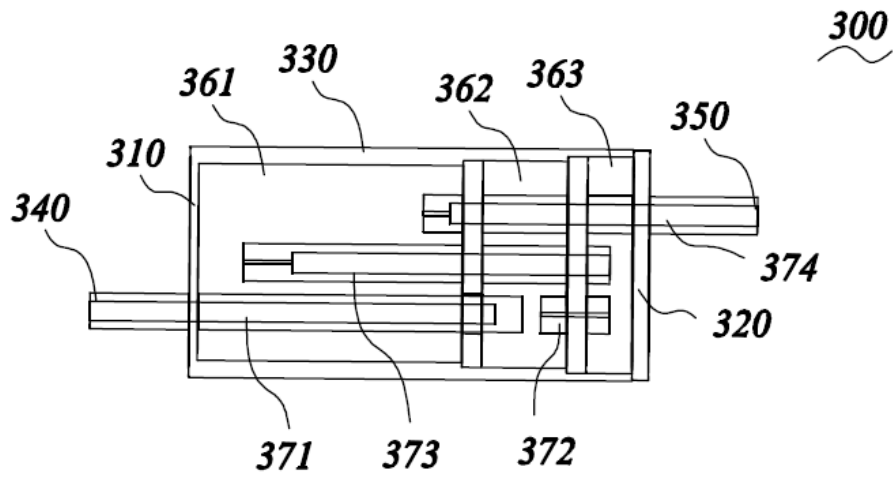

FIG.12

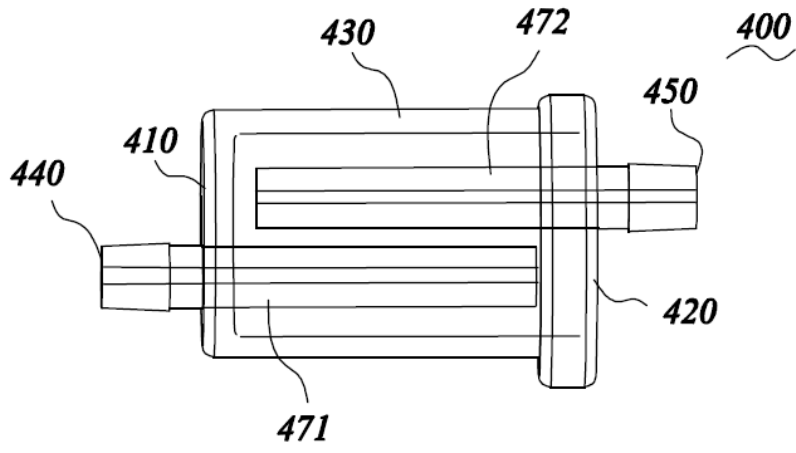

FIG.13

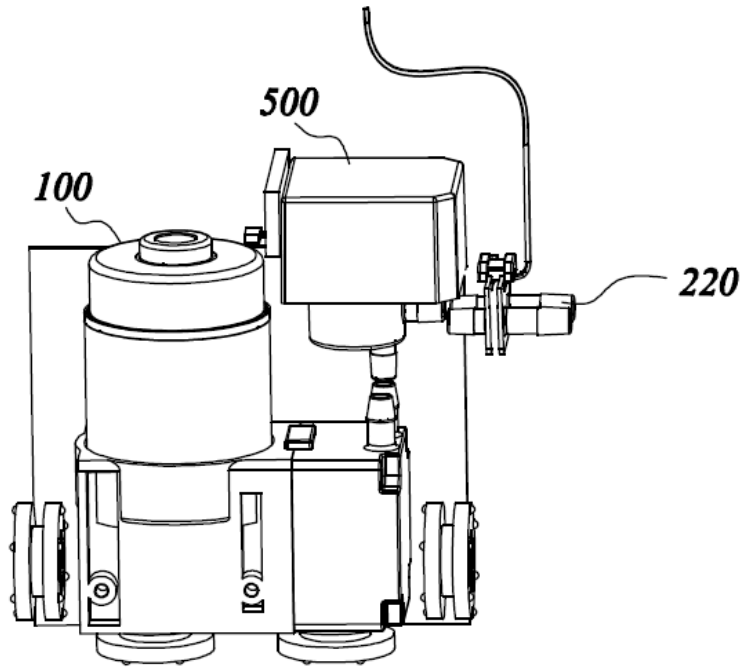

FIG.14

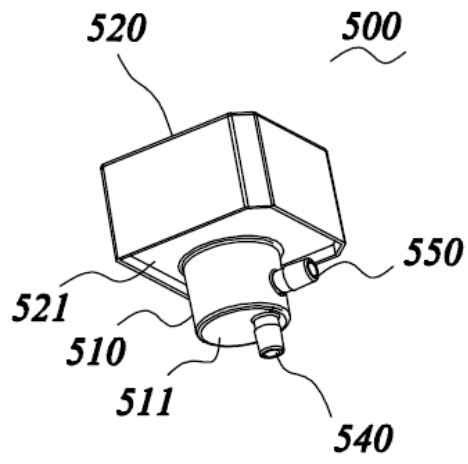

FIG.15

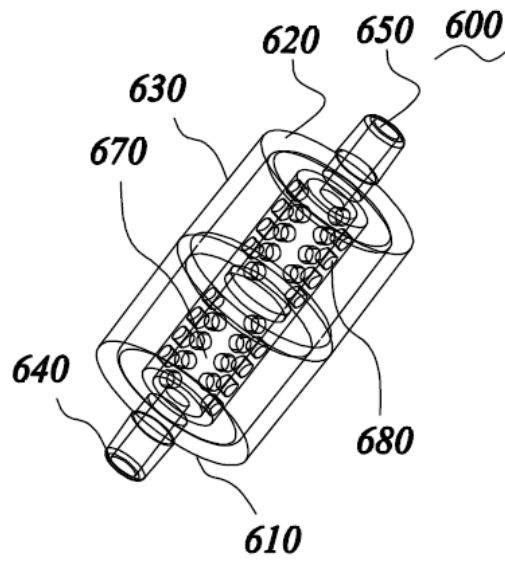

FIG.16

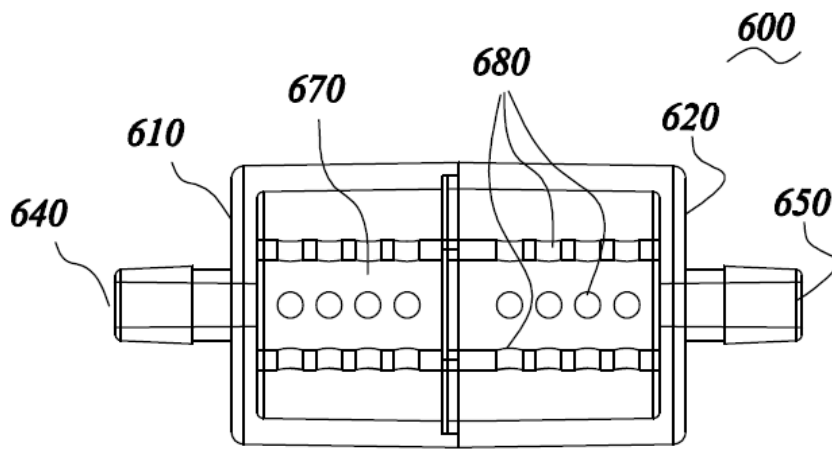

FIG.17