

Dec. 19 1922.

1,439,367

E. L. KRAG.  
BINDER.  
FILED AUG. 20, 1920.

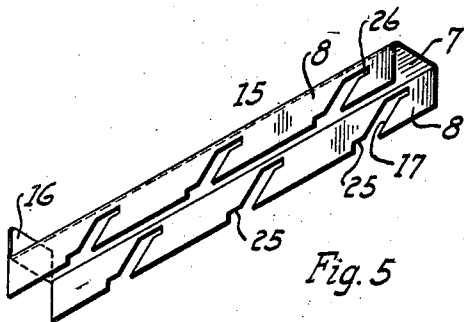
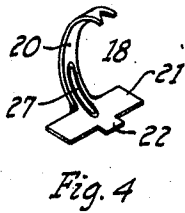
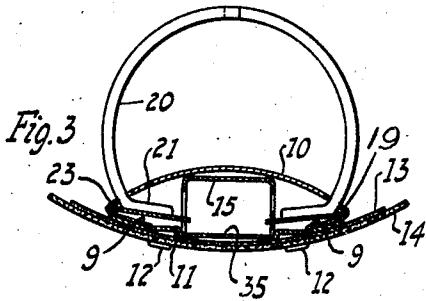
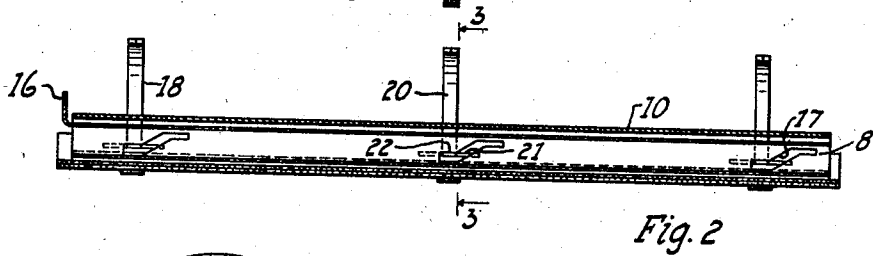
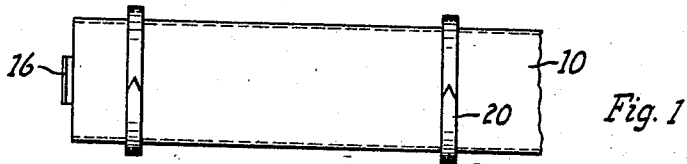

INVENTOR:

Erik L. Krag

By *E. J. Andrews*

Att'y.

## UNITED STATES PATENT OFFICE.

ERIK L. KRAG, OF CHICAGO, ILLINOIS, ASSIGNOR OF ONE-HALF TO FRANZ K. KRAG, OF CHICAGO, ILLINOIS.

## BINDER.

Application filed August 20, 1920. Serial No. 404,810.

*To all whom it may concern:*

Be it known that I, ERIK L. KRAG, a citizen of the United States, residing at Chicago, in the county of Cook and State of Illinois, have invented certain new and useful Improvements in Binders, of which the following is a specification.

This invention relates to binders for binding sheets in books or otherwise, so that the sheets when opened will lie flat and so that they can be readily removed from the binder if desired. One object of the invention is to provide a simple, inexpensive and effective binder for the purpose, which has no springs and which is so arranged as to be easily operated, and also which is dependable and durable. Another object is to provide suitable means for locking the binding elements in their closed or open positions. Other objects of the invention will be apparent from a consideration of the accompanying drawings and the description thereof.

Of the drawings Fig. 1 is a plan view of a binder, with a portion broken away, which embodies the features of my invention; Fig. 2 is a vertical, longitudinal, sectional view of the same; Fig. 3 is an enlarged transverse section along the line 3—3 of Fig. 2; Fig. 4 is a perspective view of one of the ring elements of the binder; and Fig. 5 is an under perspective view of the operating member of the binder.

The binder comprises an enclosing casing consisting of two elongated walls 10 and 11. The wall 10 has flanges 9 and lugs 12 adapted to pass through openings in the wall 11 and also through the sheet of cloth 13 and a sheet of binding board 14, or other suitable materials, the lugs being clinched on the lower side as indicated, or fastened in any other suitable manner. Within the casing is slidably mounted the operating member 15. This member may be of any suitable shape; in this instance it is a rectangular casing with a top 7 and sides 8, but with an open bottom, and having a lug 16 projecting upwardly from one end of the top by means of which it may be slid in the casing. In the sides 8 of the member 15 are inclined slots 17 which are adapted to operate the ring members 18.

The ring members are composed in general of two elements, the ring segment or prong 20 and the guide member 21. The

ring segments may be of any suitable shape, and are formed so as to coact with each other when closed in an ordinary manner. The guide members 21 consist of an elongated plate having a lug 22. The ring members are mounted in the casing with the ring portions passing through the openings 19 in the wall 10, and with the rear portions of the guide members 21 fitting snugly in the corners 23 of the casing, and with each of the lugs 22 projecting into one of the slots 17 of the operating member 15.

With the ring members thus assembled in the casing, when the operating member 15 is forced towards the right, the lugs 22 will be forced downwardly in the slots 17, and the outer ends of the ring members will come together, and will be closed when the lugs reach the lower portions of the inclined slot. A horizontal recess 25 is formed in the member 15 at the lower end of each slot 17, and by forcing the member 15 still further to the right the lugs 22 will pass into the recesses 25 and the ring members will be locked in their closed positions. On the other hand, pulling the member 15 to the left will force the lugs out of the recesses into the inclined slots and upwardly, thus opening the rings; and, finally, by pulling the member 15 outwardly to the left sufficiently the lugs 22 will pass into the horizontal recesses 26 at the upper end of the inclined slots, and the rings will be locked in their open positions. The construction and arrangement is such that when the rings are in the locked positions, either closed or open, the member 15 will be snugly held in place and sufficient force will be required to move it one way or the other, as the case may be, to insure the maintenance of the locked condition during any reasonable handling of the binder.

The ring members may be formed in any suitable way and may be independent of each other as indicated in Figs. 2 and 4. I prefer the independent finger elements, with the ring portion integral with the guide portion, the entire element being punched out of sheet metal and properly formed, and a corrugation 27 being formed in the portion thereof which bears the greatest strain.

A groove 35 is formed in the bottom of the member 11 in which the lower edges of the

operating member 15 are positioned, so as to prevent any lateral displacement of the operating member.

I claim as my invention:

- 5 1. In a binder an elongated casing having one side bowed outwardly parallel and similar flanges extending inwardly from each of the edges of said side, and forming acute angles with said side, said side having oppositely placed openings adjacent the respective edges, an operating member comprising two spaced side members longitudinally and slidably mounted in said casing between said flanges, a prong holding member having parallel elongated edges mounted in said casing with one edge in one of said angles and the other edge abutting against said operating member, a prong fixed to said prong holding member and projecting through the adjacent opening, the adjacent vertical side of said operating member having an inclined slot, and a lug extending from the adjacent edge of said prong holding member into said slot.
- 25 2. A book binder comprising an elongated casing with one side convex outwardly and having parallel edges, a flange projecting inwardly at an acute angle with said side from each of said edges, means for fastening each of said flanges to the back of a book, a rectangular casing comprising two spaced side members mounted in said first casing mentioned for longitudinal movement, each of said side members having inclined slots therein, an elongated strip mounted between each of said side members and the adjacent angle with one edge of said strip projecting into said angle and the other edge abutting against one of said side members, a lug extending from each of said strips into the adjacent inclined slot, said convex side having openings therethrough adjacent each of said angles, and a prong fixed to each of said strips and projecting through the adjacent opening.
- 45 3. A binder comprising an elongated casing, one side of said casing being convex with its long edges parallel, flanges extending at acute angles inwardly from each of said edges, the side of said casing opposite the said convex side having its respective edges fixed to said flanges and having upwardly projecting longitudinal and parallel

shoulders spaced a material distance apart and forming a groove, an operating member comprising two spaced members rigidly connected and slidably positioned in said groove with the respective members against said shoulders, prong members having elongated parallel edges mounted in said casing with one edge in said angle and the other edge abutting against the adjacent member, said members having inclined slots therein, lugs projecting from the adjacent edges of said prong members into said slots, said convex side having openings therein adjacent said angles, and prongs fixed to each of said prong members and projecting outwardly through the adjacent openings.

4. A ring binder comprising a casing, a pair of prong holders mounted for rotational movement in said casing, an operating member comprising two spaced side members slidably mounted in said casing between said prong holders and having parallel sides positioned a material distance apart, means operatively connecting each of said holders with the adjacent parallel side of said operating member and arranged to rotate said holder a limited amount when said operating member is slid in said casing.

5. In a binder an elongated casing and a binding means mounted in said casing, said casing comprising a first member and a second member, the first member having longitudinal flanges extending inwardly from its outer edges, the second member fitting against said flanges and said second member having openings therethrough, and lugs projecting from the flanges of said first member and through said openings, the ends of said lugs being clinched.

6. In a book binder an elongated casing, and leaf binding means mounted in said casing, said casing comprising a first and a second elongated strip with their edges contiguous, a sheet of book binding material fitting snugly against said second strip, and lugs passing downwardly from the first strip through said second strip and through said binding material, the ends of said lugs being clinched against said material.

In testimony whereof, I hereunto set my hand.

ERIK L. KRAG.