

J. A. THOMAS.
CONVEYER AND MIXER.
APPLICATION FILED JAN. 4, 1911.

998,048.

Patented July 18, 1911.

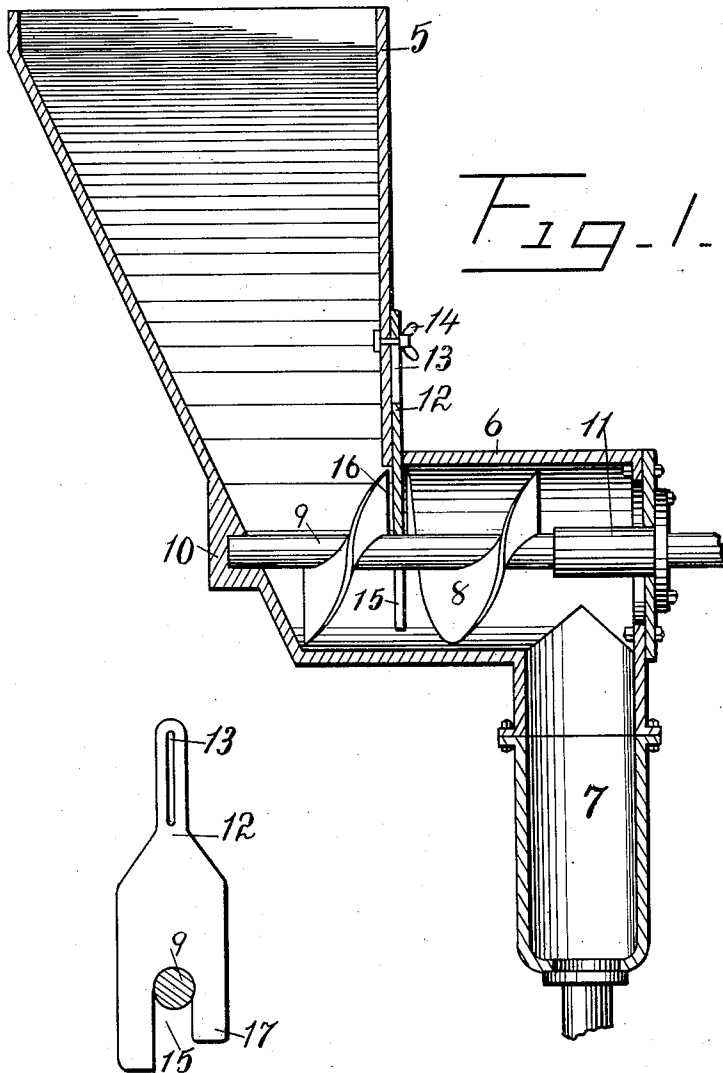

Fig. 1.

Fig. 2.

Inventor

John A. Thomas,

Witnesses
Clayton S. Dew.
A. Murray.

By *Shepherd Campbell*
Attorney

UNITED STATES PATENT OFFICE.

JOHN A. THOMAS, OF ZANESVILLE, OHIO, ASSIGNOR OF ONE-HALF TO SAMUEL A. WELLER, OF ZANESVILLE, OHIO.

CONVEYER AND MIXER.

998,048.

Specification of Letters Patent. Patented July 18, 1911.

Original application filed July 13, 1910, Serial No. 571,812. Divided and this application filed January 4, 1911. Serial No. 600,829.

To all whom it may concern:

Be it known that I, JOHN A. THOMAS, a citizen of the United States of America, residing at Zanesville, in the county of Muskingum and State of Ohio, have invented certain new and useful Improvements in Conveyers and Mixers, of which the following is a specification.

This invention relates to conveyers and mixers, and has for its object the provision of an improved structure for conducting material from a hopper to a mixing chamber, together with means for varying and controlling the amount of such material delivered.

Further objects and advantages of the invention will be set forth in the detailed description which now follows.

In the accompanying drawing, Figure 1 is a vertical section of a hopper, conveyer and mixing chamber, constructed and arranged in accordance with the invention, and, Fig. 2 is a face view of a slide employed in conjunction therewith.

Like numerals designate corresponding parts in both of the figures of the drawing.

Referring to the drawing, the numeral 5 designates a hopper which communicates at its lower end with a horizontally arranged cylinder 6. This cylinder in turn is in communication at the end farthest from the hopper, with a mixing chamber 7.

The conveyer herein shown and described is like that shown in my copending application, Ser. No. 571,812, filed July 13, 1910. Disposed within the horizontal casing 6 is a spiral conveyer 8 that is carried by a shaft 9, said shaft being journaled in bearings 10 and 11. A slide 12 has a slotted extension 13 through which a set screw 14 passes, this screw serving to bind the slide at any adjusted height. The lower portion of the slide is slotted at 15 to adapt it to straddle the shaft 9 and the spiral conveyer 8 is cut out as at 16 to clear the slide.

I am aware of the fact that it has been proposed to use slides for adjusting the flow of material to a spiral conveyer, but I am not aware that any structure has ever been employed wherein the spiral of the conveyer is cut out for the reception of the slide so that part of the conveyer lies upon each side of the slide.

Where the conveyer lies entirely outside

of the slide it is difficult to cause the material to engage with the conveyer. In the present structure, enough of the conveyer lies inside of the slide to start the material from the bottom of the hopper.

As is clearly illustrated in Fig. 2, one side of the slide is cut away at the bottom at 17 so that even when the slide is in its lowermost position, enough of an opening is left to accommodate the amount of material that will be forced therethrough by the action of the comparatively short spiral that lies to the left of said slide.

From the foregoing description, it will be seen that simple and efficient means are herein provided for accomplishing the objects of the invention, but while the elements shown and described, are well adapted to serve the purposes for which they are intended, it is to be understood that the invention is not limited to the precise construction set forth, but includes within its purview such changes as may be made within the scope of the appended claims.

Having described my invention, what I claim is:

1. In a device of the character described, the combination with a hopper, of a horizontally arranged casing at the bottom thereof, a spiral conveyer lying partly in said chamber and partly in the hopper, and a vertically adjustable slide, said spiral being cut away for the accommodation of said slide.

2. In a device of the character described, the combination with a hopper, of a horizontally arranged casing, at the bottom thereof, a spiral conveyer lying partly in said chamber and partly in the hopper, and a vertically adjustable slide, said spiral being cut away for the accommodation of said slide, and said slide being cut away to straddle the shaft of the spiral conveyer.

3. In a device of the character described, the combination with a hopper, of a horizontally arranged casing at the bottom thereof, a spiral conveyer lying partly in said chamber and partly in the hopper, and a vertically adjustable slide, said spiral being cut away for the accommodation of said slide, and said slide being cut away to straddle the shaft of the spiral conveyer, one side of the lower end of said slide being shorter than the other.

4. In a device of the character described, the combination with a hopper, of a horizontal cylindrical chamber communicating with the bottom of said hopper, a spiral conveyer lying partly in said hopper and partly in said chamber and comprising a shaft, a slide having a slotted extension which lies upon the exterior of the hopper, and a set screw for binding said slide in various positions, said slide straddling the shaft of the spiral conveyer and said spiral conveyer being cut away for the reception of said slide.

In testimony whereof I affix my signature in presence of two witnesses.

JOHN A. THOMAS.

Witnesses:

MAY RARICK,
E. F. O'NEAL.