

(No Model.)

5 Sheets—Sheet 1.

E. CHAQUETTE. DREDGING APPARATUS.

No. 523,960.

Patented July 31, 1894.

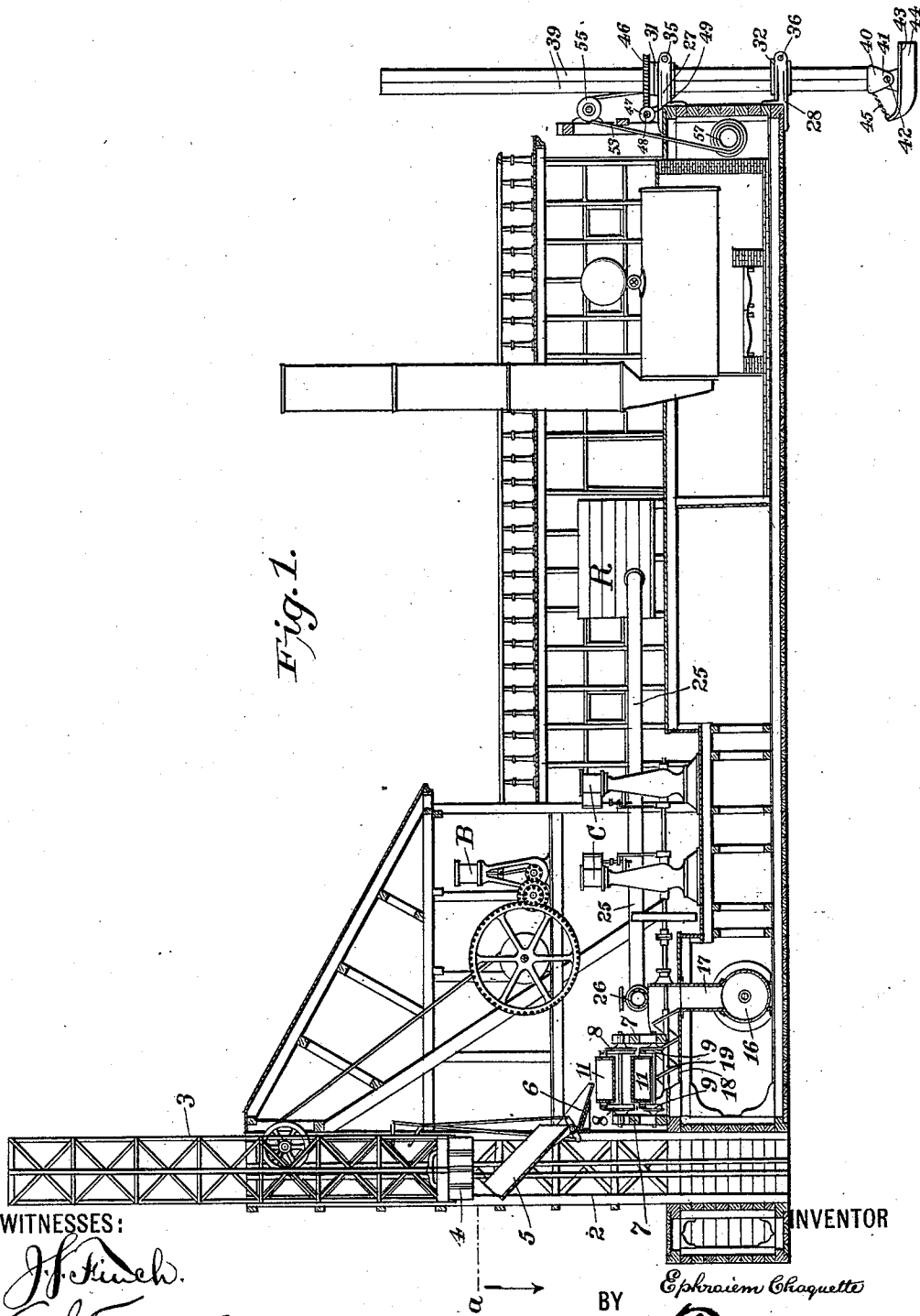

Fig. 1.

WITNESSES:

J. F. Kuech.
A. J. Tanner.

INVENTOR

Ephraim Chaquette

BY

M. Smith
ATTORNEY

(No Model.)

5 Sheets—Sheet 2.

E. CHAQUETTE. DREDGING APPARATUS.

No. 523,960.

Patented July 31, 1894.

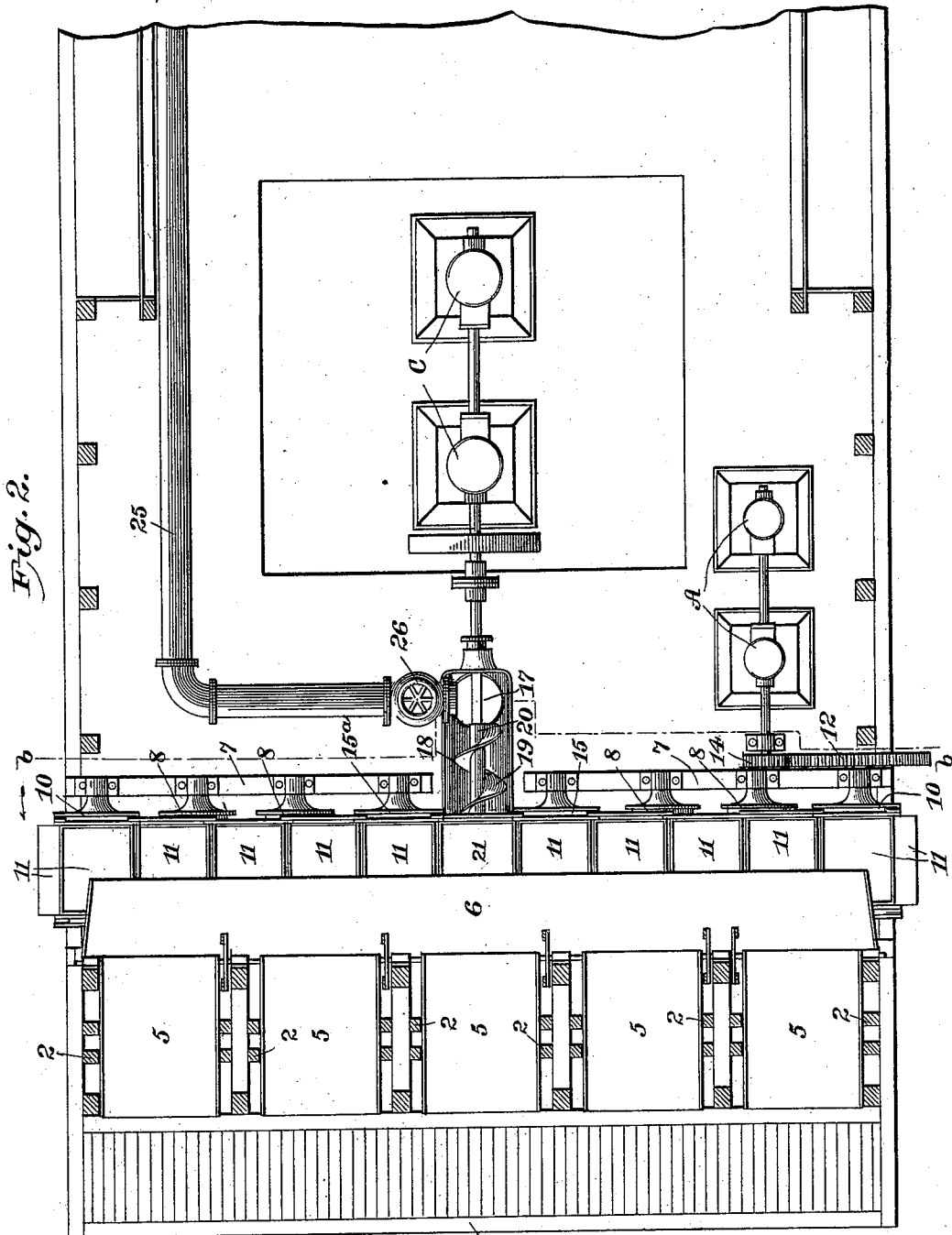

WITNESSES:

J. F. Kinch.
C. J. Tanner

INVENTOR

Ephraim Chaquette

BY

D. Smith

ATTORNEY

(No Model.)

5 Sheets—Sheet 3.

E. CHAQUETTE.
DREDGING APPARATUS.

No. 523,960.

Patented July 31, 1894.

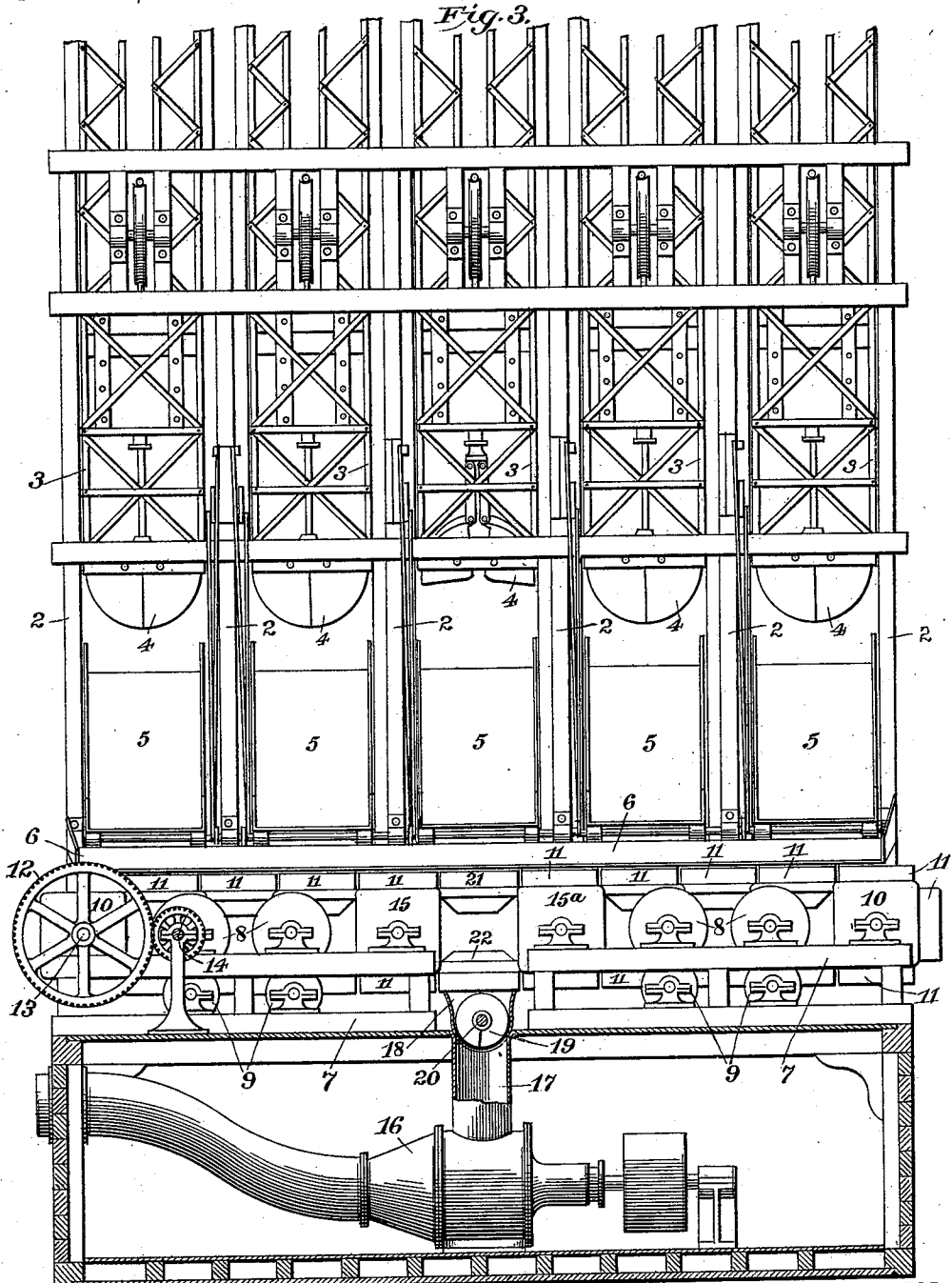

WITNESSES:

J. F. Finch.
C. J. Tamm.

INVENTOR

Ephraim Chaquette

BY

M. Smith

ATTORNEY

E. CHAQUETTE.
DREDGING APPARATUS.

No. 523,960.

Patented July 31, 1894.

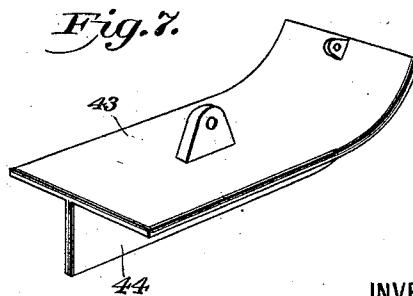
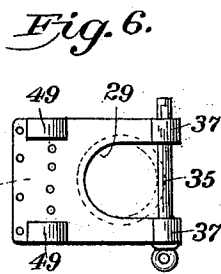
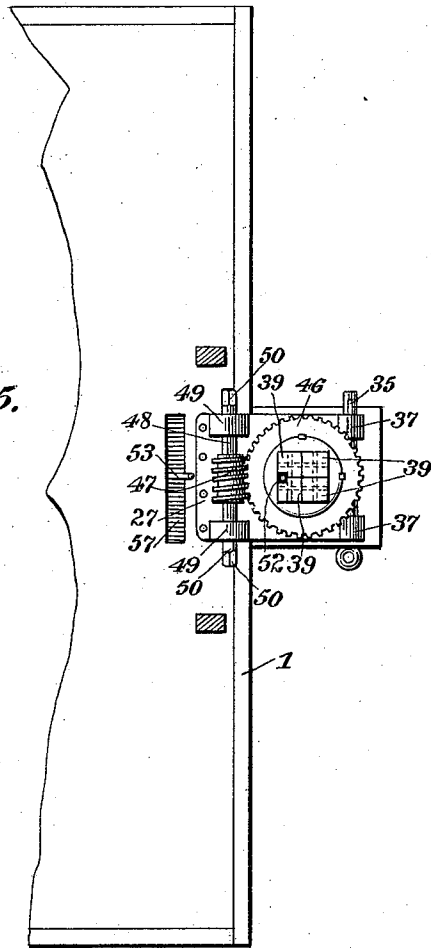
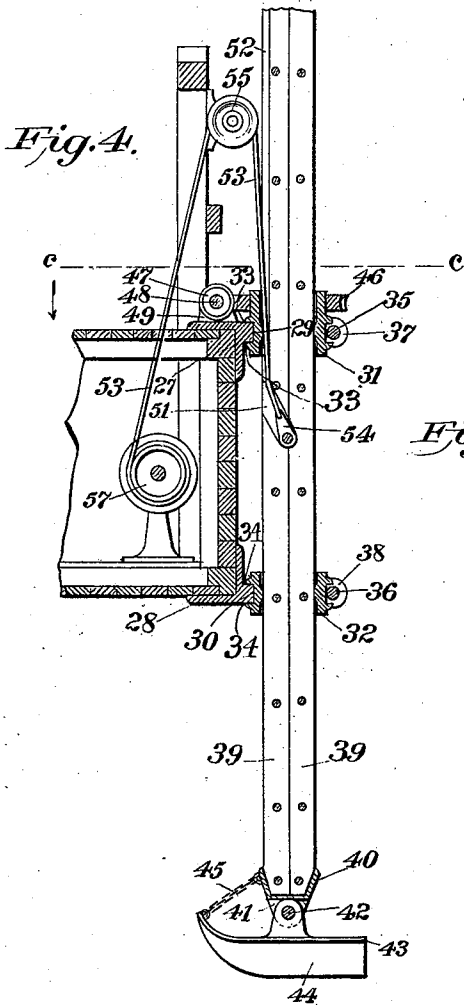

WITNESSES:

J. Kirch.
E. J. Tamm.

INVENTOR

Ephraim Chaquette

BY

P. M. Smith Jr.

ATTORNEY

(No Model.)

5 Sheets—Sheet 5.

E. CHAQUETTE.
DREDGING APPARATUS.

No. 523,960.

Patented July 31, 1894.

Fig. 8.

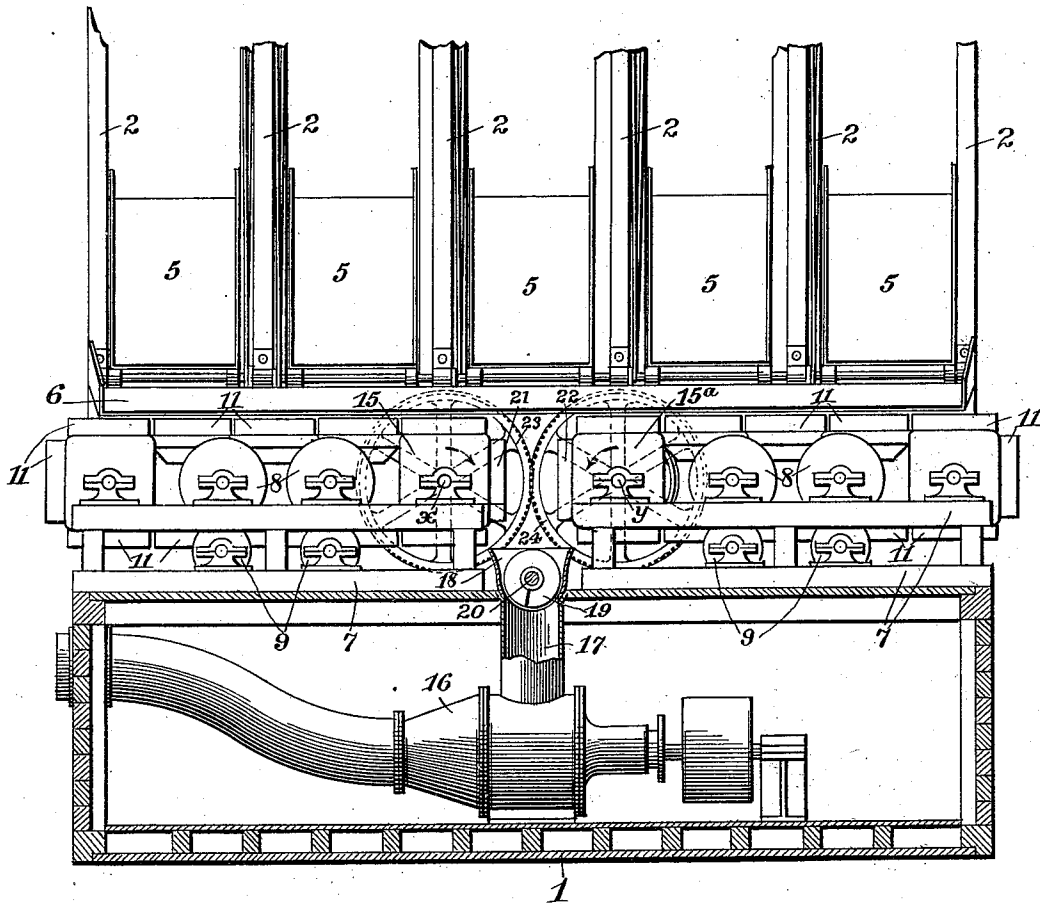

WITNESSES:

J. F. Kitch.
A. J. Tanner.

INVENTOR

Ephraim Chaquette

BY

D. Smith Jr.

ATTORNEY

UNITED STATES PATENT OFFICE.

EPHRAIEM CHAQUETTE, OF BRIDGEPORT, CONNECTICUT, ASSIGNOR TO THE CHAQUETTE CANAL AND HARBOR DREDGING COMPANY, OF SAME PLACE.

DREDGING APPARATUS.

SPECIFICATION forming part of Letters Patent No. 523,960, dated July 31, 1894.

Application filed October 27, 1893. Serial No. 489,324. (No model.)

To all whom it may concern:

Be it known that I, EPHRAIEM CHAQUETTE, a citizen of the United States, residing at Bridgeport, in the county of Fairfield and State of Connecticut, have invented certain new and useful Improvements in Dredging Apparatus; and I do hereby declare the following to be a full, clear, and exact description of the invention, such as will enable others skilled in the art to which it appertains to make and use the same.

My invention relates to dredging apparatus, and has in view the following objects:— first, to do away with the necessity of any swinging element independent of the boat, thereby enabling me to use a series of independently operated digging devices with great facility, and giving a capacity for work heretofore not obtained by any dredging apparatus; second, to insure the guiding and operation of the digging devices within a part having no movement independent of the boat; third, to facilitate the delivery of the dumpings to any suitable pump whereby they may be deposited at a remote point; fourth, to provide means whereby the boat may be swung in the arc of a circle without substantially advancing or backing the boat, whereby the area to be dredged may be operated upon with accuracy and dispatch.

In the accompanying drawings which form a part of this application—Figure 1 is a sectional elevation of my improvement; Fig. 2 a section at the line *a* of Fig. 1; Fig. 3 a section at the line *b—b* of Fig. 2; Fig. 4 a detail sectional elevation of what I will hereinafter term the “spud” and the mechanism for operating the same; Fig. 5 a section at the line *c—c* of Fig. 4; Fig. 6 a detail plan of one of the keepers for the spud; Fig. 7 a detail perspective of the spud proper, and Fig. 8 a view similar to Fig. 3, but showing particularly the arrangement of the mud bucket when the dumpings are to be delivered to any suitable pump.

Similar numbers and letters of reference denote like parts in the several figures of the drawings.

I have shown in the drawings a complete dredging apparatus, but my present invention has nothing to do with the vertical guiding of the digging elements or their construction or manner of operation, or the construction and

operation of the chutes for receiving the dumpings from the digging elements, since all these parts are constructed and operated in precisely the same manner as that shown and described in a certain other application for Letters Patent of the United States of even date herewith. I will therefore not enter into a description of these parts, it being necessary, for the purposes of this invention, to simply state that the digging devices are guided within vertical cages, and that the chutes are automatically operated by the digging devices themselves so as to always be in position to receive the dumpings.

In the apparatus shown and described in my aforesaid pending application, the vertical guides for the digging devices are rigid with a table which is capable of a swinging movement in order to carry the digging devices to different digging points. While this last named construction gives the best of satisfaction and insures a capacity more than double that of any dredging apparatus heretofore known, it is impracticable to increase the number of digging elements, since too great a weight would thereby be imposed upon the swinging element and the power to operate the latter would have to be very great. By doing away with the swinging element I thereby eliminate a great deal of power and provide an apparatus with a very great digging capacity.

1 is the boat within one end whereof is secured a series of vertical cages 2 within which latter are the frames 3 which carry the digging clams 4, the construction and operation of said frames and clams being the same as in my aforesaid pending application. These cages are all rigid together and with the boat, being in effect a part of the boat.

5 are the automatically operated chutes, one to each digging device.

6 is a shed secured in any suitable manner so as to be fixed and extending immediately beneath the chutes 5, on which shed the dumpings are received from the chutes to be delivered to the conveying devices which I will describe.

Journalled within frames 7 bolted or otherwise secured to the deck of the boat is series of rollers 8, 9, one set above the other, and at the outer ends of these frames are journalled square pulleys 10. 11 are mud buckets, which

are pivotally connected together to form a chain, and are carried, after the manner of an endless belt, by the square pulleys at the outer ends of these frames. 12 is a spur wheel secured on the shaft 13 of one of these pulleys, and 14 is a pinion suitably journaled and meshing with said spur, the shaft of which pinion is operatively connected in any suitable and ordinary manner with an engine A. Motion is therefore imparted to the chain of buckets by revolving the shaft 13 through the medium of the spur 12 and pinion 14.

15, 15^a are inner pulleys which have no function, except as hereinafter set forth and are simply idle when the buckets are connected up in one continuous series such as is necessary for the purpose of conveying the dumpings to any suitable scow at the side of the dredging boat. This series of buckets extends from one side of the boat to the other for the obvious purpose of delivering the dumpings into scows at either side of the boat. This is a feature of considerable advantage in that there need be no delay caused by the removal of a full scow and the substitution of an empty one, since when one scow is full at one side of the boat, the engine A is simply reversed thereby carrying the buckets in the opposite direction to deliver the dumpings into another scow on the opposite side of the boat.

The under set of rollers 9 support the buckets when they are carried in inverted position, while the upper set of rollers 8 support said buckets when they are full. The dumpings slide down the shed 6 into the buckets which latter are moving continuously, so that there is an uninterrupted delivery of said dumpings into the depository.

The various digging devices may be operated in pairs or singly, as may be desired, but, since they are all operated independently of each other from a single engine B, it is immaterial as to whether the digging devices perform their function in sets or in sequence. In either event there is in practice very little difference in the actual amount of dumpings delivered.

In some instances it is not found necessary to use all of the digging devices, and some of the latter may therefore remain idle, but the provision of so many of such devices is of great importance and advantage, because, if one or even two of said devices should break down or for any reason become inoperative, the capacity of the apparatus will not thereby become seriously impaired, for even then it would be greater than the capacity of any apparatus heretofore known.

I will now describe the manner in which I convey the dumpings to any suitable pump, whereby they may be deposited at a remote point.

16 is any ordinary pump such as is usually employed for forcing mud through a pipe line, and 17 is a funnel leading upwardly therefrom. 18 is a trough which extends be-

neath the series of buckets, at or about the middle part thereof, and leads directly into said funnel. 19 is a screw which extends lengthwise within said trough and whose shank 20 is operatively connected with any suitable engine C so as to be capable of revolution.

In utilizing a pump, it becomes necessary to make certain changes in the arrangement and operation of the buckets 11, and these changes I will now describe.

Referring to Figs. 3 and 8, and particularly to the latter, the upper and lower buckets 21, 22 in the chain of buckets at the middle part thereof are simply disconnected from the endless series at diagonally opposite points, and said buckets are lapped around the inner pulleys 15, 15^a and connected to opposite buckets, thus affording two separate chains of buckets the inner terminals of which chains are directly over the trough 18. In this construction it becomes necessary that the upper buckets of each series shall travel inwardly so as to deposit their contents within the trough, and this may be effected in several simple and ordinary ways, as for instance by means of two intermeshing spur wheels 23, 24, secured respectively on the shafts *x*, *y*, of the pulleys 15, 15^a, one of these shafts being suitably connected by ordinary gearing (not shown) with the engine A. As the screw revolves it will continuously draw the dumpings rearward through the trough and deposit them within the funnel 17, which latter is the direct means for supplying the pump.

25 is a pipe which leads from a reservoir R to a point directly over the funnel 17, by means of which pipe water may be delivered within the funnel so as to thin out the dumpings and make them of the consistency proper for the advantageous working of the pump. 26 is a valve in said pipe whereby the supply water may be regulated or stopped altogether if not required.

In the operation of a dredging apparatus wherein ordinary digging clams are used it becomes necessary from time to time to change the field of operation of the digging devices, and this has heretofore been done by swinging such devices bodily and independent of the boat, but in my present improvement this is effected by the swinging of the boat itself, but this would be quite a difficult and tedious matter unless the boat were equipped with some means for preventing any advancing and backing which would invariably prevent the location of the digging with any degree of accuracy.

I have provided means whereby the boat may be caused to swing in the arc of a circle without any substantial lengthwise displacement, and I will now describe the same.

Secured to the boat are keepers 27, 28, one above the other which are formed with open gates 29, 30, at their rear ends. 31, 32, are bushings within said gates and provided with annular recesses 33, 34, within which said

keepers fit so as to prevent vertical displacement of said bushings and allow them to revolve freely, and 35, 36, are pins passed through eyes 37, 38, at the rear ends of the keepers, whereby the bushings are retained in position.

The spud stem is composed of four bars 39 rectangular in cross section and bolted together, which stem extends vertically through the bushings 31, 32, the latter embracing the stem so that there can be no side play of the latter but at the same time allowing it to have a free vertical movement.

40 is a ferrule secured to the bottom of the stem and having ears 41 (only one being shown) between which is pivoted at 42 the spud 43. This spud has a flat body curved upward at the front part and has depending from its under side a center fin 44. 45 is a chain connecting the nose of this spud with the ferrule in order to prevent the displacement of the spud during operation.

Around the bushing 31 is rigidly secured a spur wheel 46 which meshes with a worm 47 on a shaft 48, which latter is journaled within ears 49 rising from the keeper 27. The outer ends of this shaft 48 are provided with wrench holds 50 whereby the worm may be revolved by means of any suitable ratchet wrench, in order to turn around the stem and the spud attached thereto.

One or more of the bars 39 has a recess 51 therein, and a groove 52 leading into said recess, whereby a cable 53 secured to any suitable tug 54 fixed in said recess may lead upward over a pulley 55 mounted on an upright 56 rising from the deck. This cable is secured to any suitable winding drum 57 which latter is operated from an ordinary hoisting engine (not shown).

When the digging devices are to be operated in a straight line, as along the edge of a channel or any other defined limit, the spud, which is located at the rear of the boat, is allowed to remain embedded in the mud and pointing in the direction of the length of the boat, so that when the boat is driven forward to bring the digging devices into a new field of operation, there can be no sidewise displacement of the boat since the spud will act as a guide to the same after the manner of a rudder but with a more positive effect.

Whenever it is desired to bring the digging devices into a certain position by swinging the boat, the stem of the spud is turned around slowly, as hereinbefore set forth, thereby causing the boat to swing in a true arc from a pivotal point. When the service of the spud is not required, it may be readily hoisted out of the mud by means of the cable 53.

The spud stem is made from stout timber, and is formed in sections, owing to the difficulty and expense of procuring a single piece of the required dimensions, and for the further reason that the sectional stem is far stronger than a solid stem.

I do not wish to be limited to the specific

construction and arrangement of the mud buckets as herein shown and described, since these may be varied without departing from the spirit of my invention, the gist of which in this respect rests in the broad idea of providing a means for receiving the mud from the shed 6 and continuously and automatically conveying the same to any suitable receptacle.

I claim—

1. In a dredging apparatus, the combination of a series of vertically disposed guide cages secured in alignment rigid with the end of the dredging boat, a series of frames within such cages and capable of being independently elevated and lowered, digging clams pivoted at the lower extremities of said frames, instrumentalities for conveying the dumpings to any suitable depository, means for receiving the dumping from the digging clams and for leading them to said instrumentalities, substantially as set forth.

2. In a dredging apparatus the combination of a series of frames carrying pivoted digging clams and guided and operated within fixed and stationary cages, the shed fixed in position, the independently operating chutes whereby the dumpings are received from the digging devices and deposited on said shed, and the endless series of buckets which receive the dumpings from the shed and carry them to any suitable receptacle, substantially as set forth.

3. In a dredging apparatus the combination of the endless series of buckets which receive the dumpings from the digging devices, the pump having the funnel extending upward therefrom, the trough below said buckets and leading into said funnel, and the screw capable of revolving within said trough and beneath the bucket, substantially as shown and described.

4. In a dredging apparatus, the vertical stationary cages secured to the end of the boat, and the frames capable of being elevated and lowered within said cages, each frame carrying a pair of pivoted digging clams, substantially as set forth.

5. In a dredging apparatus, the spud pivoted to the lower end of a rotary and vertically movable stem secured in position at the rear of the dredging boat, substantially as set forth.

6. In a dredging apparatus, the combination of suitable keepers secured to the rear of the dredging boat, bushings within these keepers, the stem within said bushings and capable of a vertical movement therein, the spud pivoted to the lower end of said stem, and means for turning said stem axially, substantially as set forth.

In testimony whereof I affix my signature in presence of two witnesses.

EPHRAIEM CHAQUETTE.

Witnesses:

F. W. SMITH, Jr.,

A. J. TANNER.