

(12) STANDARD PATENT
(19) AUSTRALIAN PATENT OFFICE

(11) Application No. **AU 2019282135 B2**

(54) Title
Cable with a fabric sleeve and its method of manufacture

(51) International Patent Classification(s)
H02G 1/08 (2006.01) **H02G 3/04** (2006.01)
H01B 7/18 (2006.01) **H02G 9/06** (2006.01)

(21) Application No: **2019282135** (22) Date of Filing: **2019.06.04**

(87) WIPO No: **WO19/236531**

(30) Priority Data

(31) Number	(32) Date	(33) Country
62/681,744	2018.06.07	US
16/429,229	2019.06.03	US

(43) Publication Date: **2019.12.12**

(44) Accepted Journal Date: **2023.08.03**

(71) Applicant(s)
Wesco Equity Corporation

(72) Inventor(s)
ALLEN, Jerry L.

(74) Agent / Attorney
Davies Collison Cave Pty Ltd, Level 15 1 Nicholson Street, MELBOURNE, VIC, 3000, AU

(56) Related Art
US 5278356 A
US 2009/0314517 A1

(12) INTERNATIONAL APPLICATION PUBLISHED UNDER THE PATENT COOPERATION TREATY (PCT)

(19) World Intellectual Property

Organization

International Bureau

(43) International Publication Date

12 December 2019 (12.12.2019)



(10) International Publication Number

WO 2019/236531 A1

(51) International Patent Classification:

H02G 1/08 (2006.01) H02G 3/04 (2006.01)

H01B 7/18 (2006.01) H02G 9/06 (2006.01)

EE, ES, FI, FR, GB, GR, HR, HU, IE, IS, IT, LT, LU, LV, MC, MK, MT, NL, NO, PL, PT, RO, RS, SE, SI, SK, SM, TR), OAPI (BF, BJ, CF, CG, CI, CM, GA, GN, GQ, GW, KM, ML, MR, NE, SN, TD, TG).

(21) International Application Number:

PCT/US2019/035315

(22) International Filing Date:

04 June 2019 (04.06.2019)

(25) Filing Language:

English

(26) Publication Language:

English

(30) Priority Data:

62/681,744 07 June 2018 (07.06.2018) US

16/429,229 03 June 2019 (03.06.2019) US

(71) Applicant: WESCO DISTRIBUTION, INC. [US/US];

225 West Station Square Drive, Suite 700, Pittsburgh, Pennsylvania 15219-1122 (US).

(72) Inventor: ALLEN, Jerry L.; 340 Morningside Drive,

Sarasota, Florida 34236 (US).

(74) Agent: GREIVE, Edward G. et al.; Huntington Tower,

Suite 400, 106 South Main Street, Akron, Ohio 44308 (US).

(81) Designated States (unless otherwise indicated, for every

kind of national protection available): AE, AG, AL, AM, AO, AT, AU, AZ, BA, BB, BG, BH, BN, BR, BW, BY, BZ, CA, CH, CL, CN, CO, CR, CU, CZ, DE, DJ, DK, DM, DO, DZ, EC, EE, EG, ES, FI, GB, GD, GE, GH, GM, GT, HN, HR, HU, ID, IL, IN, IR, IS, JO, JP, KE, KG, KH, KN, KP, KR, KW, KZ, LA, LC, LK, LR, LS, LU, LY, MA, MD, ME, MG, MK, MN, MW, MX, MY, MZ, NA, NG, NI, NO, NZ, OM, PA, PE, PG, PH, PL, PT, QA, RO, RS, RU, RW, SA, SC, SD, SE, SG, SK, SL, SM, ST, SV, SY, TH, TJ, TM, TN, TR, TT, TZ, UA, UG, US, UZ, VC, VN, ZA, ZM, ZW.

(84) Designated States (unless otherwise indicated, for every

kind of regional protection available): ARIPO (BW, GH, GM, KE, LR, LS, MW, MZ, NA, RW, SD, SL, ST, SZ, TZ, UG, ZM, ZW), Eurasian (AM, AZ, BY, KG, KZ, RU, TJ, TM), European (AL, AT, BE, BG, CH, CY, CZ, DE, DK,

Published:

— with international search report (Art. 21(3))

(54) Title: CABLE WITH A FABRIC SLEEVE AND ITS METHOD OF MANUFACTURE

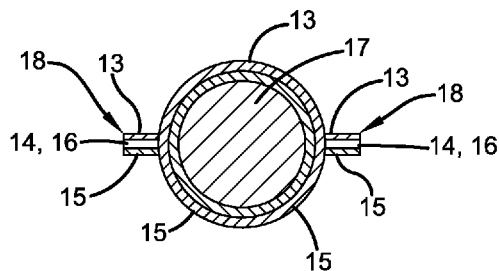

FIG. 2

(57) Abstract: A fabric wrapped cable is formed by positioning adhesive on opposed layers of fabric. A cable is positioned between those layers and the layers are attached by attaching the adhesive of one layer to the adhesive of the other layer. In forming the wrapped cable in such a manner, the cable is provided with at least one wing.



WO 2019/236531 A1

2019282135 29 Jun 2023

CROSS-REFERENCE TO RELATED APPLICATION

This application claims priority from U.S. Provisional Patent Application Serial No. 62/681,744 filed on June 7, 2018, which is incorporated herein by reference in its entirety.

5

TECHNICAL FIELD

This invention relates to a fabric enclosed cable and the method of assembling a cable with a fabric sleeve so that the cable may be easily inserted into a communications conduit.

10

BACKGROUND

Positioning cables in underground communication conduits which extend for several thousand feet has long been a problem. Such is particularly true when it is desired to position an additional cable or cables into a conduit that already has a cable in it. That cable, particularly because of its plastic jacket, provides a great deal of friction to the new cable as it is being inserted into the conduit. As a result, the new or the existing cable may be damaged due to that friction. Such is particularly true when the cable in the conduit is unguilating which causes the cable being introduced to take a sinuous, friction-laden path.

15

20

An extremely successful solution to this problem is a fabric innerduct sold under the trademark MAXCELL® by TVC Communications, LLC and shown in U.S. Patent No. 6,262,371 which is incorporated herein by reference for whatever details may be necessary to understand the present invention. This innerduct is first positioned in a conduit and divides the conduit into longitudinally extending compartments. A cable can be positioned in one of the compartments, and a pull tape or rope can be positioned in another compartment which can later be utilized to pull a second cable into that compartment. Because there is fabric between the cables, the friction is not on the cable jacket but on the fabric which makes installation easier.

25

30

However, a problem can exist when using these innerducts in small diameter conduits which extend long distances. In these small conduits, the fabric

innerduct takes up much of the space in the conduit and the tape or rope may tend in lock up in the innerduct thereby impeding the ability to pull in a cable.

As a result, a fabric encased cable was designed as shown in U.S. Patent No. 9,054,507 which is incorporated herein by reference for whatever details may be necessary to understand the present invention. While such represents a vast improvement in the art, an improved cable and a simple manner in which to attach the fabric to the cable has not yet been developed.

It is desired to address or ameliorate one or more drawbacks or disadvantages of the prior art, or at least provide a useful alternative.

SUMMARY

In at least one embodiment, the present invention provides a method of confining a cable having a length in a single sheet of fabric material and inserting the confined cable into a conduit comprising the steps of positioning an adhesive only on the lateral edges of said fabric, folding the sheet of fabric to form opposed layers of fabric, then positioning a cable along the length of said fabric between the layers, attaching the adhesive of one lateral edge of the sheet to the adhesive of the other lateral edge of the sheet to confine the cable between the layers without permitting the adhesive to contact the cable thereby not adhesively bonding the cable directly to the layers, and thereafter inserting the confined cable into the conduit.

In at least another embodiment, the present invention provides a method of confining a cable in a single sheet of fabric material comprising the steps of positioning an adhesive only on the lateral edges of a single sheet of fabric material, positioning a release strip on the adhesive at each lateral edge, folding the single sheet of material to form opposed layers of material with the lateral edges of the material adjacent to each other, then positioning the cable between the layers of material by passing the cable between the lateral edges of the material, removing the release strips after the cable has been positioned between the lateral edges of the sheet layers, and thereafter attaching the adhesive of one layer to the adhesive

of the other layer to confine the cable between the layers without adhering the fabric material directly to the cable with the adhesive.

In at least a further embodiment, the present invention provides an apparatus to be inserted into a longitudinally extending conduit comprising a cable, having a length and a coefficient of friction, a single sheet of fabric having a coefficient of friction less than that of the cable and having an adhesive only at its lateral edges, said sheet of material being attached at its lateral edges to encase said cable along its length without adhesively bonding said cable directly to said sheet, and at least one wing formed when the edges of the fabric are connected and extending outwardly from said cable along the length of said cable, said fabric not adhesively bonded directly to said cable, and said cable encased within said sheet being more easily inserted into the conduit.

BRIEF DESCRIPTION OF THE DRAWINGS

One or more embodiments of the present invention are hereinafter described, by way of example only, with reference to the accompanying drawings, in which:

Fig. 1 is a sectional view of a cable positioned between two layers of fabric material.

Fig. 2 is a sectional view like Fig. 1 but showing the layers wrapped around the cable.

Fig. 3 is a fragmented top plan view of that which is depicted in Fig. 2.

Fig. 4 is a sectional view of an alternative embodiment to that shown in Fig. 1, and showing a cable positioned between two layers of fabric material.

Fig. 5 is a sectional view like Fig. 4 but showing the layers wrapped around the cable.

Fig. 6 is a sectional view of yet another embodiment depicting two opposed layers of material.

Fig. 7 is a sectional view showing that which is shown in Fig. 6 wrapped around a cable.

Fig. 8 is a fragmented top plan view of that which is depicted in Fig. 7.

DETAILED DESCRIPTION

5 In general, a method of attaching a fabric material to a cable includes the steps of positioning an adhesive on opposed layers of fabric, positioning a cable between the layers, and attaching the adhesive of one layer to the adhesive of the other layer to confine the cable between the layers.

The wrapped cable formed by this method includes a fabric encased cable having at least one wing extending outwardly from the cable.

10 Methods to make a fabric encased cable with wings are depicted in the accompanying drawings without attempting to show all the various forms and modifications in which the invention might be embodied, the invention being measured by the appended claims and not by the details of the specification.

15 A conventional communications cable is indicated by the numeral 10 in the drawings. Cable 10 traditionally includes core of wires covered by a plastic sheath. Such cables are usually stored on a roll, which may carry 2500 feet or more of cable.

20 As shown in Fig. 1, in order to wrap a cable 10 with a pliant material, such as a fabric with a lower coefficient of friction than the sheath of the cable, a first sheet assembly, generally indicated by the numeral 11, and a second sheet assembly, generally indicated by the numeral 12, are provided. Sheet assembly 11 extends longitudinally along the length of cable 10 and includes a fabric layer 13 having an adhesive layer 14 attached thereto. Similarly, sheet assembly 12 extends longitudinally along the length of cable 10 and includes a fabric layer 15 having an adhesive layer 16 attached thereto.

25 In order to create the fabric wrapped cable 17 shown in Fig. 2, assemblies 11 and 12 are positioned as shown in Fig. 1 such that adhesive layers 14 and 16 are opposed to each other with the conventional cable 10 being positioned between layers 14 and 16. Then assemblies 11 and 12 are wrapped around cable 10 with adhesive layers 14 and 16 engaging cable 10 to form wrapped cable 17. The lateral edges of assemblies 11 and 12 form wings 18 when the lateral edges of adhesive layers 14 and 16 engage each other. The wings 18 extend radially outwardly from generally diametrically opposed sides of cable 17.

Such wings 18 tend to add strength to the cable 17, and they can be utilized to pull the cable into a conduit. That is, a pulling device can be attached to, or otherwise grasp, the wings of a cable to insert it into a conduit.

5 The wrapped cable 17 can be created by longitudinally moving cable 10 together with sheet assemblies 11 and 12 and providing a folding station. When the cable 10 and assemblies 11 and 12 pass through that station, assemblies 11 and 12 are wrapped around cable 10 as previously described. Such can be accomplished at the manufacturing site of the cable, or such can be provided at the site where the wrapped cable 17 is to be installed in a conduit. In that instance, a
10 roll of cable 10 and rolls of sheet assemblies 11 and 12 can be provided and fed through a device which will wrap cable 10 as the resultant cable 17 is being installed in a conduit.

An alternative manner in which to wrap a cable 10 is shown in Figs. 4 and 5. There, a first sheet assembly 21 and a second sheet assembly 22 are
15 provided. Sheet assembly 11 includes a fabric layer 23, which can be identical to fabric layer 13. Sheet assembly 23 also includes an adhesive layer which is formed of two small layers 24 located at the lateral peripheries of fabric layer 23. Similarly, sheet assembly 22 includes a fabric layer 25 which can be identical to fabric layer
20 15. Sheet assembly 22 also includes an adhesive layer which is formed of two small layers 26 located at the lateral periphery of fabric layer 25.

In order to create the fabric wrapped cable 17 shown in Fig. 5, assemblies 21 and 22 are positioned as shown in Fig. 4, the adhesive layers 24 and 26 being opposed to each other with cable 10 being positioned between sheet assemblies 21 and 22. Then assemblies 21 and 22 are wrapped tightly around
25 cable 10 and adhesive layers portions 24 engage adhesive layer portions 26, as shown in Fig. 5 to form wings 28. It is also contemplated that the embodiment of Fig. 5 will satisfactorily create a cable 17 if only one of the sheet assemblies 23, 25 is provided with an adhesive portion 24 or 26. Thus, the remaining adhesive portion would be attached directly to the opposed sheet assembly. In either event, the
30 resulting plan view of Fig. 5 is identical to Fig. 3. The resulting fabric wrapped cable 17 can be manufactured in the same manner as described with respect to the embodiment of Figs. 1-3.

5

10

Another cable wrapping version is shown in Figs. 6-8. There, one continuous sheet of fabric material, generally indicated by the numeral 30, is folded to form a first fabric layer 33 having a small adhesive layer 34 at the end thereof, and forms a second fabric layer 35 having a small adhesive layer 36 at the end thereof. When material 30 is manufactured, a release sheet 37 is positioned on each adhesive layer 34, 36. When it is desired to create the fabric wrapped cable 17 shown in Fig. 7, a cable 10 is positioned between layers 33 and 35 by extending it through the opening between adhesive layers 34 and 36. Then the release sheets 37 are removed from adhesive layers 34, 36, and layers 33 and 35 are tightened around cable 10 to form a wrapped cable 17 with the adhesive layers 34, 36 being attached to each other to form a wing 38.

15

In view of the foregoing, it should thus be evident that any of the disclosed options for creating a wrapped cable will substantially improve the art. Throughout this specification and the claims which follow, unless the context requires otherwise, the word "comprise", and variations such as "comprises" and "comprising", will be understood to imply the inclusion of a stated integer or step or group of integers or steps but not the exclusion of any other integer or step or group of integers or steps.

20

The reference in this specification to any prior publication (or information derived from it), or to any matter which is known, is not, and should not be taken as an acknowledgment or admission or any form of suggestion that that prior publication (or information derived from it) or known matter forms part of the common general knowledge in the field of endeavour to which this specification relates.

25

THE CLAIMS DEFINING THE INVENTION ARE AS FOLLOWS:

1. A method of confining a cable having a length in a single sheet of fabric material and inserting the confined cable into a conduit comprising the steps of positioning an adhesive only on the lateral edges of said fabric, folding the sheet of fabric to form opposed layers of fabric, then positioning a cable along the length of said fabric between the layers, attaching the adhesive of one lateral edge of the sheet to the adhesive of the other lateral edge of the sheet to confine the cable between the layers without permitting the adhesive to contact the cable thereby not adhesively bonding the cable directly to the layers, and thereafter inserting the confined cable into the conduit.

2. A method of confining a cable in a single sheet of fabric material comprising the steps of positioning an adhesive only on the lateral edges of a single sheet of fabric material, positioning a release strip on the adhesive at each lateral edge, folding the single sheet of material to form opposed layers of material with the lateral edges of the material adjacent to each other, then positioning the cable between the layers of material by passing the cable between the lateral edges of the material, removing the release strips after the cable has been positioned between the lateral edges of the sheet layers, and thereafter attaching the adhesive of one layer to the adhesive of the other layer to confine the cable between the layers without adhering the fabric material directly to the cable with the adhesive.

3. An apparatus to be inserted into a longitudinally extending conduit comprising a cable, having a length and a coefficient of friction, a single sheet of fabric having a coefficient of friction less than that of the cable and having an adhesive only at its lateral edges, said sheet of material being attached at its lateral edges to encase said cable along its length without adhesively bonding said cable directly to said sheet, and at least one wing formed when the edges of the fabric are connected and extending outwardly from said cable along the length of said cable, said fabric not adhesively

bonded directly to said cable, and said cable encased within said sheet being more easily inserted into the conduit.

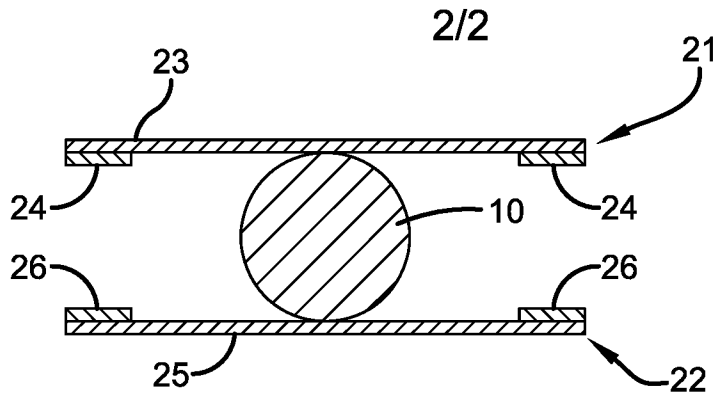

FIG. 4

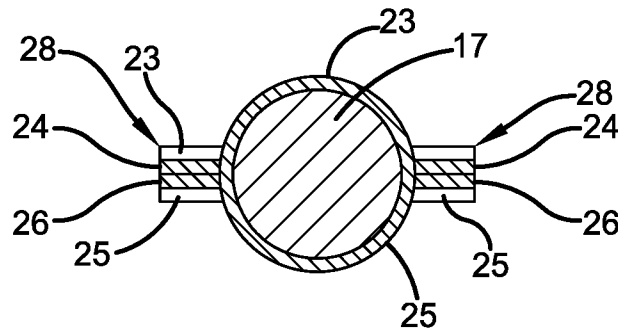

FIG. 5

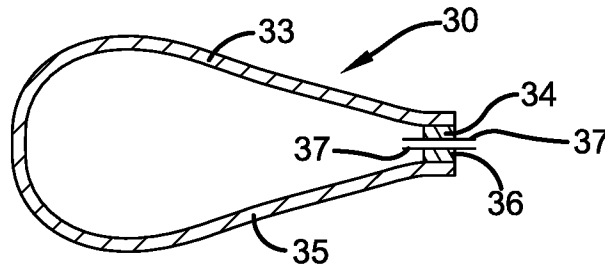

FIG. 6

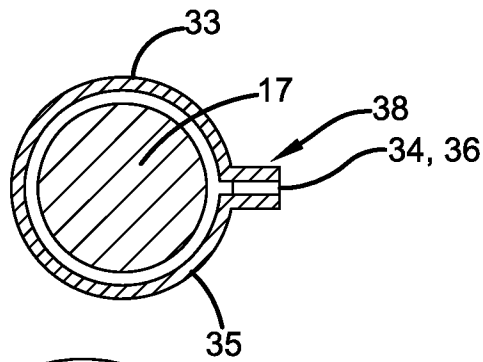

FIG. 7

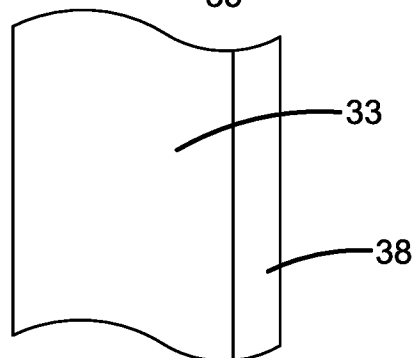

FIG. 8