



INTERNATIONAL APPLICATION PUBLISHED UNDER THE PATENT COOPERATION TREATY (PCT)

<p>(51) International Patent Classification ⁶ : G01N 1/14</p>	<p>A1</p>	<p>(11) International Publication Number: WO 98/10265</p> <p>(43) International Publication Date: 12 March 1998 (12.03.98)</p>												
<p>(21) International Application Number: PCT/US97/15866</p> <p>(22) International Filing Date: 9 September 1997 (09.09.97)</p> <p>(30) Priority Data:</p> <table border="0"> <tr> <td>60/025,694</td> <td>9 September 1996 (09.09.96)</td> <td>US</td> </tr> <tr> <td>60/024,724</td> <td>9 September 1996 (09.09.96)</td> <td>US</td> </tr> <tr> <td>60/026,853</td> <td>10 September 1996 (10.09.96)</td> <td>US</td> </tr> <tr> <td>60/025,871</td> <td>9 October 1996 (09.10.96)</td> <td>US</td> </tr> </table> <p>(71) Applicant: SHERWOOD MEDICAL COMPANY [US/US]; 1915 Olive Street, St. Louis, MO 63103 (US).</p> <p>(72) Inventors: CONLEY, Paul, G.; 3059 St. Daphne, St. Charles, MO 63301 (US). APPAL, Eugene, R.; 2040 Valencia, Florissant, MO 63303 (US). MERWIN, Jeff; 2712 Sunny Meadows, St. Charles, MO 63303 (US).</p> <p>(74) Agents: SMITH, Montgomery, W.; American Home Products Corporation, One Campus Drive, Parsippany, NJ 07054 (US) et al.</p>		60/025,694	9 September 1996 (09.09.96)	US	60/024,724	9 September 1996 (09.09.96)	US	60/026,853	10 September 1996 (10.09.96)	US	60/025,871	9 October 1996 (09.10.96)	US	<p>(81) Designated States: AL, AM, AT, AU, AZ, BA, BB, BG, BR, BY, CA, CH, CN, CU, CZ, DE, DK, EE, ES, FI, GB, GE, HU, IL, IS, JP, KE, KG, KP, KR, KZ, LC, LK, LR, LS, LT, LU, LV, MD, MG, MK, MN, MW, MX, NO, NZ, PL, PT, RO, RU, SD, SE, SG, SI, SK, TJ, TM, TR, TT, UA, UG, UZ, VN, ARIPO patent (GH, KE, LS, MW, SD, SZ, UG, ZW), Eurasian patent (AM, AZ, BY, KG, KZ, MD, RU, TJ, TM), European patent (AT, BE, CH, DE, DK, ES, FI, FR, GB, GR, IE, IT, LU, MC, NL, PT, SE), OAPI patent (BF, BJ, CF, CG, CI, CM, GA, GN, ML, MR, NE, SN, TD, TG).</p> <p>Published <i>With international search report.</i></p>
60/025,694	9 September 1996 (09.09.96)	US												
60/024,724	9 September 1996 (09.09.96)	US												
60/026,853	10 September 1996 (10.09.96)	US												
60/025,871	9 October 1996 (09.10.96)	US												

(54) Title: ELECTRONICALLY MONITORED MECHANICAL PIPETTE

(57) Abstract

The pipette (10) of the present invention includes a housing (12) having a first generally cylindrical bore (14) passing longitudinally therethrough which contains a transducer assembly (20) centrally located therein, a microswitch assembly (50) positioned at the proximal end thereof and a barrel assembly (30) attached to the distal end thereof to extend outwardly in the distal longitudinal direction. The housing (12) also includes a smaller longitudinal bore (16) containing an ejector rod (18), held in its proximal most position by ejector spring (22) and prevented from escaping the smaller bore (16) by O-ring (24). An electronic assembly (40) is attached to the proximal end of the housing (12) and extends away from the housing (12) in a generally perpendicular direction.

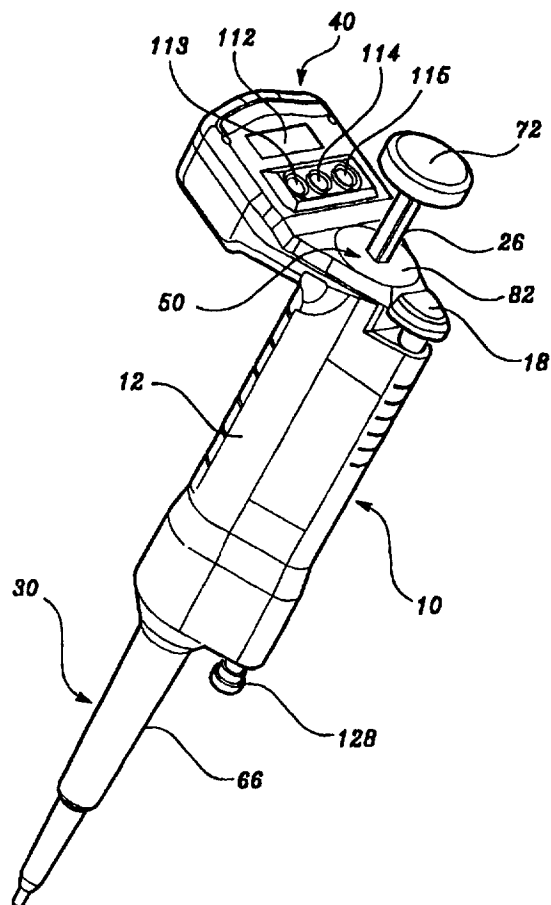

FOR THE PURPOSES OF INFORMATION ONLY

Codes used to identify States party to the PCT on the front pages of pamphlets publishing international applications under the PCT.

AL	Albania	ES	Spain	LS	Lesotho	SI	Slovenia
AM	Armenia	FI	Finland	LT	Lithuania	SK	Slovakia
AT	Austria	FR	France	LU	Luxembourg	SN	Senegal
AU	Australia	GA	Gabon	LV	Latvia	SZ	Swaziland
AZ	Azerbaijan	GB	United Kingdom	MC	Monaco	TD	Chad
BA	Bosnia and Herzegovina	GE	Georgia	MD	Republic of Moldova	TG	Togo
BB	Barbados	GH	Ghana	MG	Madagascar	TJ	Tajikistan
BE	Belgium	GN	Guinea	MK	The former Yugoslav Republic of Macedonia	TM	Turkmenistan
BF	Burkina Faso	GR	Greece	ML	Mali	TR	Turkey
BG	Bulgaria	HU	Hungary	MN	Mongolia	TT	Trinidad and Tobago
BJ	Benin	IE	Ireland	MR	Mauritania	UA	Ukraine
BR	Brazil	IL	Israel	MW	Malawi	UG	Uganda
BY	Belarus	IS	Iceland	MX	Mexico	US	United States of America
CA	Canada	IT	Italy	NE	Niger	UZ	Uzbekistan
CF	Central African Republic	JP	Japan	NL	Netherlands	VN	Viet Nam
CG	Congo	KE	Kenya	NO	Norway	YU	Yugoslavia
CH	Switzerland	KG	Kyrgyzstan	NZ	New Zealand	ZW	Zimbabwe
CI	Côte d'Ivoire	KP	Democratic People's Republic of Korea	PL	Poland		
CM	Cameroon	KR	Republic of Korea	PT	Portugal		
CN	China	KZ	Kazakistan	RO	Romania		
CU	Cuba	LC	Saint Lucia	RU	Russian Federation		
CZ	Czech Republic	LI	Liechtenstein	SD	Sudan		
DE	Germany	LK	Sri Lanka	SE	Sweden		
DK	Denmark	LR	Liberia	SG	Singapore		
EE	Estonia						

ELECTRONICALLY MONITORED MECHANICAL PIPETTE**Technical Field**

The invention relates generally to an electronically monitored mechanical pipette. More specifically, the invention relates to an electronically monitored volume delivery adjustment mechanism for a pipette and a detachable barrel therefore.

Background Art

Mechanically operated micropipettes are well known in the art as exemplified by U.S. Patent No. 4,909,991 to Oshikubo. In such prior art devices, the volume of liquid to be dispensed by the pipette is generally indicated to the operator by means of a mechanical display. The display commonly consists of a set of rotary drums driven by a gear mechanism attached to the actuating shaft of the pipette, such that rotation of the actuating shaft causes the drums to rotate to display a new setting. However, due to unavoidable mechanical wear and tear on pipettes, the amount of fluid actually being delivered by a pipette may not actually correspond to the volume being indicated by the mechanical displayed. Further, accuracy may degrade over time as the actuating elements, such as the shaft, gears, and rotary drum, wear out.

Electrically driven pipettes are also well known in the art as exemplified by U.S. Patent No. 4,905,526 to Magnussen, Jr. et al. This type of instrument commonly includes an electronic display for displaying the volume of fluid to be dispensed by the pipette, and an actuator generally comprised of an electric drive mechanism, such as a stepper motor. The stepper motor generally drives a rotor, which is attached by a threaded screw to an actuator shaft, the threaded screw changes the

rotational motion of the motor into linear motion of the actuator shaft. The shaft thereafter drives a piston to displace fluid for pipetting. Although electrically operated pipettes have some advantages over mechanically operated pipettes, they nevertheless suffer from several drawbacks. First, the enlarged size of an electrically operated pipette, due to the need to accommodate the electric driving mechanism, and the added electronic hardware, make the device very difficult to handle for the operator. Further, the electronic motor can be very power demanding and thus necessitate connection of the pipette to a power source, or the use of large batteries which can be rapidly drained of power.

Electrically monitored mechanical pipettes are also known in the art as exemplified by U.S. Patent No. 4,567,780 to Oppenlander, et al. This type of instrument generally includes a plunger having an adjustable stroke length which is generally adjusted by rotating the plunger itself. The electrical monitoring system monitors plunger rotation and electronically displays the volume delivery setting corresponding to the plunger position. The device continuously monitors the plunger position and volume delivery setting of the pipette by means of a potentiometer. Although this vice overcomes several of the disadvantages of mechanical and electrical pipettes, it nevertheless fails to completely resolve the problem of high power demands during operation. Further, the use of a potentiometer to monitor the position of the plunger is sometimes not desirable.

Electrically driven pipettes which include a transducer assembly are also well known in the art as exemplified by U.S. Patent No. 4,821,586 to Scordato et al. This instrument uses a Hall-effect transducer to indicate when the volume delivery adjustment mechanism

to be set to a desired volume delivery setting. However, the volume delivery setting is calculated based on the number of pulses applied to the windings of an actuation motor, when in turn determines the number of steps a threaded element rotates through a known pitch threads. This indicates the distance the plunger moves longitudinally from the "home" position, thus determining the stroke of the piston and the volume of fluid which will be aspirated into the tip of the pipette. Although the electrically driven pipette uses a Hall-effect switch to assist in positioning the volume delivery adjustment mechanism, it nevertheless suffers from several drawbacks. First, the Hall-effect transducer is used only as a switch to indicate a "home" position from which a volume delivery setting can be made, instead directly monitoring the entire range of movement of the volume delivery adjustment mechanism and thereby directly indicating all positions of the mechanism to the electronic assembly of the unit. Therefore, fluid delivery setting cannot be determined directly from the output of the Hall-effect transducer.

Disclosure of Invention

The principal object of the present invention is to provide an electrically monitored mechanical pipette with a continuous volume delivery setting display and low power consumption.

Another object of the present invention is to provide an electrically monitored mechanical pipette which activates the electrical volume monitoring system thereof only when the volume delivery setting is being changed.

Another object of the present invention is to provide an electrically monitored mechanical pipette which includes a microswitch as a part of the volume

consumption of the pipette by providing a signal to power up the electrical volume monitoring system only when the volume delivery setting is being changed.

Another object of the present invention is to
5 provide an electronically monitored mechanical pipette which includes a calibration system which requires no mechanical adjustment of the pipette for recalibration.

A further object of the present invention is to
10 provide an electronically monitored mechanical pipette with a calibration system which allows for calibration of the pipette at any desired fluid delivery setting, so that the pipette is calibrated specifically to maximize accuracy at the fluid delivery setting desired.

A further object of the present invention is to
15 provide an electronically monitored mechanical pipette which includes a calibration system which does not lose accuracy due to normal wear and tear of the internal mechanical mechanism of the pipette.

Another object of the present invention is to
20 provide an electronically monitored mechanical pipette having an electronic volume monitoring system which utilizes a monitoring assembly and an electronics assembly to monitor the position of a volume delivery adjustment mechanism and to compute and display fluid
25 volume delivery settings.

Another object of the present invention is to
provide an electronically monitored mechanical pipette which includes a transducer assembly as part of an
30 electronic volume monitoring system for monitoring the position of volume delivery adjustment mechanism of the pipette.

Another principal object of the present invention
is to provide an electronically monitored mechanical
35 pipette as described above in which the transducer assembly tracks the movement of the volume delivery

system can recompute a new fluid volume delivery setting based directly on the output signals of the transducer assembly.

A further object of the present invention is to
5 provide an electronically monitored mechanical pipette as described above in which the transducer assembly uses an annular shaped bar magnet which rotates adjacent to a plurality of magnetic field sensors to generate the signals which are sent to the electrical assembly of the
10 electrical volume monitoring system for its use in computing the fluid volume delivery setting of the pipette.

A further object of the present invention is to provide an electronically monitored mechanical pipette
15 as described above in which the transducer assembly of the electrical volume monitoring system is capable of recognizing the direction of movement of the fluid delivery setting mechanism of the pipette and the electrical assembly of the electrical volume monitoring
20 system can precisely calculate the fluid volume delivery setting to be delivered by the pipette at any time.

Another object of the present invention is to provide an electronically monitored mechanical pipette which includes a detachable barrel which can be cleaned
25 such as by autoclaving, and replaced on the pipette.

Another object of the present invention is to provide an electronically monitored mechanical pipette with a removable barrel which is completely self-contained such that removing the barrel from the pipette
30 maintains all internal barrel and pipette components in place.

A further object of the present invention is to provide an electronically monitored mechanical pipette which includes a removable barrel system which allows
35 both single and multiple channel barrels to be removably

Briefly, and in general terms, the present invention provides for electronically monitoring a mechanical pipette which enables low power operation of the electronics thereof during use of the device to pipette fluid, and engages high powered electronics only when necessary to provide monitoring of the pipette while the operator is resetting the desired fluid volume delivery setting and for recomputation of the new setting. The present invention also includes a removable barrel which is completely self-contained such that removing the barrel from the pipette maintains all internal barrel and pipette components in place. Further, the invention includes a transducer assembly and an electronics assembly which allow monitoring and positioning indication of the volume and delivery adjustment mechanism of the pipette. Finally, the invention includes an electronic volume monitoring system which allows general calibration of the pipette with the added ability of specific calibration of the pipette at a desired fluid volume delivery setting.

In the presently preferred embodiment, shown by way of example and not necessarily by way of limitation, an electrically monitored mechanical pipette made in accordance with the principals of the present invention includes a volume delivery adjustment mechanism which includes a plunger, an advancer, a driver, and a threaded bushing. The volume delivery adjusted mechanism is monitored by an electrical volume monitoring system which preferably includes a transducer assembly having two Hall-effect sensors, and an electronics assembly which includes a microprocessor and a display. During volume delivery adjustment, the sensors send a set of transducer signals to the electronics assembly computes and displays the new fluid volume delivery setting.

A microswitch assembly is provided for detecting relative rotational motion between the volume delivery adjustment mechanism and the pipette and to signal the electronics assembly that the fluid volume delivery setting is being changed. Upon receipt of a signal, in the form of an interrupt signal, from the microswitch, the electronics assembly powers up the transducer assembly which then tracks the motion of the volume delivery adjustment mechanism. The transducer sensor signals are received by the electronics assembly which computes and displays the new fluid volume delivery setting. Once the volume delivery adjustment mechanism is no longer being rotated, the electronics assembly shuts down the power to the transducer assembly to minimize power use of the pipette.

In one preferred embodiment of the microswitch assembly, a bobber mechanism is positioned such that the volume delivery adjustment mechanism causes a switch, such as a metal contact pad, in the mechanism to move up and down as the volume delivery adjustment mechanism rotates. This up and down motion of the switch causes it to intermittently contact and release a stationary switch pad mounted on the electronics assembly. In this manner, a signal such as an interrupt signal is sent by the bobber mechanism to the electronics assembly each time the bobber switch pad contacts the stationary electronics switch pad. The interrupt signal causes the electronics assembly to power up the transducer assembly for monitoring the motion of the volume delivery adjustment mechanism.

Another preferred embodiment of the microswitch assembly includes a bobber which is in physical contact with a spring loaded switch which is activated each time the bobber moves up and down.

In one preferred embodiment of the detachable

which the piston adaptor thereof passes through an enclosed housing area to attach to a single piston which draws fluid through a single fluid channel.

In another preferred embodiment of the barrel assembly, the piston adaptor thereof passes through the enclosed barrel housing and attaches to a piston bar, which in turn drives several pistons through several individual fluid channels for receiving and delivering multiple channels simultaneously. The barrel housing of each of the single and multiple channel barrel assemblies are totally self-contained such that removal of the barrel assembly from the pipette does not result in the loss or displacement of any elements of either the pipette or the barrel assembly.

Each barrel assembly of the present invention is capable of being cleaned such as by autoclaving while separated from the pipette and can thereafter be easily reattached to the pipette for further use.

The transducer assembly is preferably a Hall-effect transducer which detects the magnitude of a magnetic field. In the preferred embodiment of the Hall-effect transducer, an annular magnet is positioned about a magnet bearing which will rotate with the rotating elements of the volume delivery adjustment mechanism, while the remainder of the transducer assembly remains stationary with respect to the pipette. As the annular magnet rotates, its magnetic field relative to any fixed point, varies sinusoidally. The transducer assembly preferably includes more than one sensor, each spaced 90° apart from each other within the rotating magnetic field. When two sensors are used, the output of the first sensor is 90° out of phase with the output of the second sensor. When the magnet rotates within the transducer assembly, the resulting sensor output is two sinusoidal signals, one signal being 90° out of phase

The sine-cosine combination of output signals from the two sensors allows the electronics assembly of the pipette to pin point the precise rotational position of the volume delivery adjustment mechanism and also the direction in which the volume delivery adjustment mechanism is being adjusted.

The annular magnet used in the transducer assembly of the present invention is manufactured to cause its north and south pole to be located at points on the circumference of the annular magnet, 180 apart from each other (diametrically), instead of being positioned on the top and bottom of the annular magnet. In this manner, rotation of the annular shaped magnet about its central axis causes the north and south poles thereof to alternatively move past the sensors as the volume delivery adjustment mechanism is rotated.

The electronics assembly of the pipette condition and process the signals received from the transducer assembly. Each transducer signal is fed into a microprocessor of the electronics assembly and the voltage thereof is measured. This input is used by the microprocessor as input data to an algorithmic computation of the present fluid volume delivery setting which is then displayed.

The electronics assembly preferably computes the new fluid volume delivery setting based on comparison of the transducer sensors signals with a calibration map which had been previously generated and loaded into the microprocessor thereof by rotating the volume delivery adjustment mechanism through one full revolution and recording the transducer sensor signals at predetermined rotational intervals. The transducer sensor signals received by the microprocessor thereafter are compared to the calibration map and the predetermined fluid volume delivery setting associated with the transducer

The fluid volume delivery setting associated with any particular set of values in the calibration map can be reset at any time by the operator. Due to this ability, the operator can check the actual fluid volume being delivered by the pipette at any displayed setting, and adjusts the display setting to the actual volume being delivered. In this manner, the pipette is calibrated for delivery of exact fluid volume at the desired fluid volume delivery setting.

In an alternative embodiment, the microprocessor of the electronics assembly can be preprogrammed with an algorithm which computes the fluid volume delivery setting based on the transducer sensor signals being received.

The transducer assembly is preferably a Hall-effect transducer which detects the magnitude of a magnetic field. In the preferred embodiment of the Hall-effect transducer, an annular magnet is positioned about a magnet bearing which will rotate with the rotating elements of the volume delivery adjustment mechanism while the remainder of the transducer assembly remains stationary with respect to the pipette. As the annular magnet rotates, its magnetic field relative to any fixed point, varies sinusoidally. The transducer assembly preferably includes more than one sensor, each spaced 90° apart from each other. When two sensors are used, the output of the sensor is 90° out of phase with the other sensor. When the magnet rotates within the transducer assembly, the resulting output is two sinusoidal signals, one signal being 90° out of phase from the other.

The sine-cosine combination of output signals from the two sensors allows the electronic assembly of the pipette to pin point the precise rotational position of the volume delivery adjustment mechanism and also the

direction in which the volume delivery adjustment mechanism is being adjusted.

The annular magnet used in the transducer assembly of the present invention is manufactured to cause its north and south pole to be located at points on the circumference of the annular magnet, 180 apart from each other, instead of being positioned from the top and bottom of the annular magnet. In this manner, rotation of the annular shaped magnet causes the north and south poles thereof to alternatively rotate past the sensors as the volume delivery adjustment mechanism is rotated.

The electronics assembly of the pipette condition and process these signals received from the transducer assembly. Each transducer signal is fed into a microprocessor of the electronics assembly and the voltage thereof is measured. This input is used by the microprocessor as input data to an algorithmic computation of the present fluid volume delivery setting which is then displayed. Alternatively, the microprocessor may be preprogrammed with a map of transducer output values which the microprocessor can match to the signals being received. Each set of values in the map corresponds to a particular fluid volume delivery setting which the microprocessor causes to be displayed.

These and other objects and advantages of the present invention will become apparent from the following more detailed description, when taken in conjunction with the accompanying drawings in which like elements are identified with like numerals throughout.

Brief Description of Drawings

Figure 1 is a perspective view of a pipette made in accordance with the principals of the present invention;

Figure 2 is a front view of the pipette of Figure

Figure 3 is a cross-sectional view taken along line III-III of Figure 2;

Figure 4 is a perspective view of a preferred embodiment of an electronics assembly and a transducer assembly made in accordance with the principals of the present invention;

Figure 5 is a cross-sectional view of a transducer assembly made in accordance with the principals of the present invention; Figure 6 is a cross-sectional view taken along line VI-VI of Figure 5;

Figure 7 is an exploded view of a preferred embodiment of a microswitch assembly made in accordance with the principals of the present invention;

Figure 8 is a perspective view of a preferred embodiment of a microswitch assembly and an electronics assembly made in accordance with the principals of the present invention with the housing of the electronics assembly removed;

Figure 9 is a side view of the microswitch assembly and electronics assembly of Figure 8;

Figure 10 is a perspective view of a detachable barrel assembly made in accordance with the principals of the present invention;

Figure 11 is a front view of the detachable barrel assembly of Figure 10;

Figure 12 is a cross-sectional view taken along line XII-XII of Figure 11;

Figure 13 is a perspective view of a second preferred embodiment of a pipette made in accordance with the principals of the present invention which includes a second preferred embodiment of a detachable barrel assembly;

Figure 14 is a front view of the second embodiment of a pipette of Figure 13;

Figure 15 is a cross-sectional view of the second embodiment of a pipette taken along line XV-XV of Figure 14;

5 Figure 16 is an expanded view of the multi channel detachable barrel assembly made in accordance with the principals of the present invention;

Figure 17 is a front view of the preferred embodiment of the multi channel barrel assembly with the front cover thereof removed;

10 Figure 18 is a cross-sectional view taken along line XVIII-XVIII of Figure 17;

Figure 19 is a graph of outputs of two Hall-effect sensors of a transducer assembly made in accordance with the principals of the present invention;

15 Figure 20 is a flow chart of the preferred embodiment of the method for generating a calibration map according to the principals of the present invention; and

20 Figure 21 is a perspective view of a second preferred embodiment of a microswitch assembly made in accordance with the principals of the present invention.

Mode(s) for Carrying Out the Invention

25 As shown in the exemplary drawings for the purposes of illustration, an embodiment of an electronically monitored mechanical pipette made in accordance with the principals of the present invention, referred to generally by the reference numeral 10, is provided for continuous low power display of the fluid volume delivery setting of the pipette, and for temporary high
30 power activation of the electrical volume monitoring system whenever the volume delivery setting is being changed by an operator.

More specifically, as shown in Figures 1-3, the pipette 10 of the present invention includes a housing

longitudinally therethrough which contains a transducer assembly 20 centrally located therein, a microswitch assembly 50 positioned at the proximal end thereof and a barrel assembly 30 attached to the distal end thereof to extend outwardly in the distal longitudinal direction. The housing 12 also includes a smaller longitudinal bore 16 containing an ejector rod 18, held in its proximal most position by ejector spring 22 and prevented from escaping the smaller bore 16 by O-ring 24. An electronic assembly 40 is attached to the proximal end of the housing 12 and extends away from the housing 12 in a generally perpendicular direction. The housing 12 is designed to be easily gripped in a single hand of an operator such that the electronic assembly 40 remains above the operator's hand for easy viewing by the operator, and the barrel assembly 30 extends below the operator's hand for easy positioning thereof. The pipettor 10 can be operated by manipulation of the ejector rod 18 and the square plunger 26 by the user's thumb as will be explained in more detail below.

ASSEMBLY

Referring again to Figures 1-3, assembly of the pipettor 10 of the present invention is preferably initiated with the barrel assembly 30. First, the piston 28 is inserted into the primary spring 32. The proximal end of the piston 28 is then affixed to the piston adaptor 34 and the distal end of piston 28 is inserted into the fluid channel 36 of the barrel housing 42. The fluid channel 36 is sealed against leakage therepast by means of a plug 38, preferably made of Teflon, through which the piston 28 passes and which seats itself in the distal portion of the barrel housing 42 just above the fluid channel 36. The plug 38 is secured for a fluid tight fit against the piston 28 by

distal portion of the barrel housing 42 by washer 46 which is biased downward by the primary spring 32. The force of the washer 46 against the seal 44 assists the seal 44 in squeezing the plug 38 against the piston 28 and also assists in forcing the plug 38 downward against the proximal end of the fluid channel 36. This assists in preventing fluid leakage out of the fluid channel 36. Finally the annular disk 48 is inserted over the piston adaptor 34 and snap-fit into the distal opening of the barrel housing 42. The enlarged end 52 of the piston adaptor 34 is larger in diameter than the annular disk opening 54 and allows the piston adaptor 34 to move longitudinally relative to the barrel housing 42 yet does not allow it to be completely removed therefrom. This completes barrel assembly 30.

Turning now to the housing 12, the primary washer 56 is inserted into the distal end of the housing 12 until it abuts with the shoulder 62 thereof. The secondary spring 60 is then inserted into the distal end of the housing 12 until it abuts primary washer 56. The secondary washer 61 is then placed against the secondary spring 60 to abut with shoulder 58 of the housing 12. The primary washer 56, secondary spring 60 and secondary washer 61 are then permanently held in place within the housing 12 by press fitting the bushing barrel 64 into the distal end of the housing 12. The bushing barrel 64 is threaded on its interior surface and the proximal end of the barrel housing 42 of the barrel assembly 30 is threaded on its exterior surface. In this manner, the entire barrel assembly 30 can be removably attached to the housing 12 by threading the barrel housing 42 into the bushing barrel 64.

Figures 10-12 show the entire barrel assembly 30 when removed from the remainder of the pipette 10. As can be seen the piston adaptor 34 is held within the

in the annular disk opening 54. The primary spring 32 holds the piston adaptor 34 in its fully extended position. While detached from the pipette 10, the barrel assembly 30 can be cleaned such as by autoclaving
5 without causing any damage to any elements thereof. When it is desired to reattach barrel assembly 30 to the pipette 10, the piston adaptor 34 is passed into the housing 12 and through the primary washer 56 and secondary washer 61, and the barrel housing 42 is
10 rotated to engage the threads of the bushing barrel 64. The barrel housing 42 is rotated until the threads are completely threaded, and the end of the piston adaptor 34 abuts the small bushing 78. The ejector barrel 66 is then slid over the barrel housing 42 and nut 128 is
15 screwed on to the bottom end of ejector rod 18. Thereafter, the pipette 10 is again ready to receive a disposable tip (not shown) for use.

Figures 13-15 show a second preferred embodiment of the barrel assembly of the present invention attached to
20 the pipette 10 for use. The second embodiment of the detachable barrel assembly is referred to generally by the numeral 158. The multi channel barrel assembly 158 operates in a nearly identical manner as the single channel barrel assembly 30 described above, except in
25 that a plurality of doses are delivered.

Specifically, as can best be seen in Figures 16-18, the multi channel barrel assembly 158 is removable from the remainder of the pipette 10 by unscrewing it from the pipettor housing 12. When detached, multi channel
30 barrel assembly 158 remains in tact without any elements therein becoming separated or misplaced. The piston adaptor 34 is held in its fully extended position by one or more primary springs 32, and a plurality of pistons 28 are positioned in a plurality of channels 36. The
35 only substantial operational difference between the

barrel assembly 130 of the present invention is the inclusion in multi channel barrel assembly 158 of a piston bar 156 which is attached directly to the piston adaptor 34 and which in turn has the pistons 28 attached directly thereto. In this manner, movement of the single piston adaptor 34 simultaneously operates all of the pistons 28 for simultaneously drying and dispensing fluid from the plurality of channels 36.

The multi channel barrel assembly 158 does not employ the ejector rod 18 for ejecting pipette tips (not shown) from the bottom of the barrel housing 42. Instead, an ejector assembly 160 is activated to remove the pipette tips. The user merely presses downwardly on thumb pad 162 which causes the ejector bar 164 to move downwardly against the springs 168 and thus push the pipette tip from the end of the fluid channels 36. When the thumb pad 162 is released, the springs 168 return the ejector bar 164 to its original position, and the barrel assembly 158 is ready to receive a new set of pipette tips.

Referring now to Figures 3-5, the transducer assembly 20 includes an annular magnet 116 encased in the transducer housing 118 and held in position on the transducer bearing 130 by abutment against shoulder 120. Sensors 122 and 124 are positioned within the transducer housing 118 at positions 90° apart from each other. The sensors 122 and 124 operate to track the rotation of the annular magnet 116. Leads 134 and 136 extend from the sensors 122 and 124 up to the electronics assembly 40 to allow the sensor signals to pass to the electronics assembly 40.

As best seen in Fig. 3, the square plunger 26 is next inserted through the advancer 74. The transducer driver 76 is then inserted over the distal end of the plunger 26 and attached to the distal end of the

end of the transducer driver 76 forms a reduced diameter threaded extension to which a small bushing 78 is threadedly attached. The small bushing 78 is of a larger diameter than the plunger 26 and thus interferes with the distal end of the transducer driver 76 to preventing the plunger 26 from being withdrawn therefrom.

Referring now to Figures 3 and 7, the microswitch assembly 50 is assembled by first sliding the square opening of the bobber guide 82 over the proximal end of the square plunger 26, and attaching the button 72 to the proximal end of the plunger 26. Next, the bobber 80 is inserted over the bobber guide 82 and the bobber switch 84 is inserted over the bobber 80 and held in place by the retaining ring 86. The bobber spring 88 is then inserted over the bobber guide 82 until it abuts against the retaining ring 86 and the retainer 90 is attached to the distal end of the bobber guide 82. Threads 138 of the advancer 74 are then advanced into the threads 140 of bushing 70. The bobber guide 82 is then inserted into the bushing 70 until the retainer 90 snap fits into a retainer slot 92 in the interior annular surface of the bushing 70 just above threads 140. This action causes the bobber spring 88 to be biased between the retaining ring 86 and shoulder 94 in the proximal end of the bushing 70. In this manner, the bobber 80 is always biased upward against the enlarged flange portion 96 of the bobber guide 82. When completely assembled, the bobber 80 is prevented from rotating by the keys 142 thereon which match keyways (not shown) in bore 16. Similarly, pin 144 prevents the advancer 74 from rotating above the threaded portion of the bushing 70, and a key and keyway (not shown) are used to prevent rotation of the transducer housing 118. Thus, rotation of button 72 by the operator causes the

rotate and translate in the upward or downward direction. Translational (longitudinal) distance is controlled by the pitch of threads 138 and 140, and the number of rotations of the button 72.

5 Likewise, rotation of button 72 causes rotation (but not translation) of bobber guide 82, transducer bearing 130 and annular magnet 116.

 The rotational motion of the bobber guide 82 causes the bobber 80 to move downwardly. Since the bobber 80
10 is held against rotation by the keys 142 positioned in keyways (not shown) in the bore 16, the bobber 80 must move downwardly to unmesh bobber teeth 146 from bobber guide teeth 148. This downward motion causes the bobber switch 84 to contact the stationary switch pad 98, and
15 continues until the bobber teeth 146 slip past the bobber guide teeth 148. This downward movement distance in the preferred embodiment is approximately .030 inches. The bobber 80 is then biased upwardly again by bobber spring 88. This continues as further rotation
20 occurs, and results in a "bobbing" motion of bobber 80 until rotation of the button 72 is stopped.

 Once the transducer assembly 20 and microswitch assembly 50 are completed, the transducer assembly 20 is inserted into the housing 12 through the proximal
25 opening of bore 14 and held in position against shoulder 68 by bushing 70. The bushing 70 includes flattened surfaces (not shown) which form small longitudinal channels (not shown) in conjunction with the bore 14, through which the leads 134 and 136 pass from the
30 transducer assembly 20 to the electronics assembly 40.

 The stationary switch pad 98 is held in position at the top of the housing 12 by screws or the like, and a portion thereof extends into the bore 14 to contact and assist in retaining the bushing 70 in its proper
35 position within the bore 14. The bobber switch 84

is held in a spaced apart position therefrom by the bobber spring 88.

As shown in Figures 8 and 9, the stationary switch pad 98 is in electrical contact with the electronic assembly 40 and likewise forms part of the electrical volume monitoring system by being attached to the negative side of the batteries 100 through lead 102 and to the positive side of the circuit board 104 by lead 106. The circuit board itself is connected to the positive side of the batteries 100 by lead 108. The circuit board 104 has attached thereto the microprocessor 110, the LCD display 112, the calibration buttons 113, 114, 115 and the leads 134 and 136 from the transducer assembly 20.

Finally, referring now to Figure 3, the ejector spring 22 is inserted over the ejector rod 18 and the ejector rod 18 is subsequently inserted through the small bore 16 of the housing 12. The O-ring 24 is attached to a distal portion of the rod 18 to retain it within the small bore 16. The distal end of ejector rod 18 is threaded and sized to receive the ejector barrel 66 which is held in place by nut 128.

In use, a disposable pipette tip (not shown) is attached to the distal end of the barrel housing 42 to be in fluid flow communication with the fluid channel 36 and to abut the distal end of the ejector barrel 126. When it is desired to dispose of the pipette tip, the operator presses down on the ejector rod 18 with the thumb of the hand holding the pipette 10. This causes the ejector rod 18 and the ejector barrel 66 to move distally and push the pipette tip off of the distal end of the barrel housing 42.

Referring to Figures 3 and 5, the transducer assembly 20 allows the electronics assembly 40 to determine the angular position of the volume delivery

setting of the pipette 10. The transducer assembly generates signals from preferably two Hall-effect sensors 122 and 124 which are oriented 90° from each other. These sensors 122 and 124 are positioned
5 equidistant from the perimeter of annular magnet 116. As the annular magnet 116 rotates, its magnetic field also rotates. This results in the two sensors 122 and 124 generating nearly sinusoidal outputs that differ in phase by 90°. This phase difference allows the
10 electronics assembly 40 to determine the position of the volume delivery adjustment mechanism and thus the fluid volume delivery setting of the pipette.

The preferred Hall-effect sensors 122 and 124 are relatively high impedance surface mount, linear,
15 sensors. A sensor of this type which is preferable for use with the present invention is manufactured by Toshiba as THS129. Each sensor 122 and 124 are surface mounted on a board 170 and 172 respectively, and each includes an amplifier such as is common in the art. An
20 amplifier suitable for use with the present invention is manufactured by Analog Devices as AD626. These amplifiers are a single supply, low voltage, and low power amplifiers.

The output of the transducer assembly 20 is
25 directly proportional to the magnetic field that is applied to the Hall-effect sensors 122 and 124. The sensitivity of the Hall-effect sensors 122 and 124 is controlled by fixed resistors (not shown) which is common in the art. The single fixed control resistor
30 for each of the sensors 122 and 124 were selected based on the physical dimensions of the transducer assembly 20 and the distance between the annular magnet 116 and the sensors 122 and 124 after assembled in the pipette 10. The value of the resistors was influenced by the
35 sensitivity thereof to the applied magnetic field, the

the required dynamic range for the output signals from the sensors 122 and 124 as is understood in the art. Further, the resistors were optimized according to the desired amount of overlap between the signals from the sensors 122 and 124. In order to minimize signal errors, a dynamic range is maximized within the limits of the desired signal overlap.

The annular magnet 116 is formed of an injection molded plastic body having magnetic media suspended within the plastic. During manufacture of the annular magnet 116, while the plastic thereof is in a molten state, the magnetic media is oriented diametrically across the diameter thereof and is magnetized preferably to approximately 400 Gauss. By orienting and magnetizing the annular magnet 116 across its diameter, the annular magnetic 116 generates a field similar to a bar magnet.

When the annular magnet 116 is rotated, the sensors 122 and 124 of the transducer assembly sense the changes in the magnetic field, and their outputs change proportionally with the magnetic field. As the south pole of the annular magnet 116 approaches the sensors 122 and 124, the output thereof grows in a positive direction. As the north pole of the annular magnet 116 approaches the sensors 122 and 124, the output grows in a negative direction. This increase and decrease in output yields a nearly sinusoidal output signal from each of the sensors 122 and 124.

The phase relationship of the sinusoidal signals from the sensors 122 and 124 make it possible to determine the exact rotational position of the volume delivery adjustment mechanism. The position is determined by the electronics assembly 40 based on the current signal levels it is receiving from each sensor 122 and 124.

Referring to Figure 19, the transducer signals 174 and 176 from sensors 122 and 124 respectively are shown for one complete rotation of the volume delivery adjustment mechanism of the pipette 10. The graph is marked in increments of 90° rotation to form four 90° quadrants. Each 90° quadrant marking is placed such that one of the signals 174 or 176 is changing from positive to negative and the other signal 174 or 176 is remaining either in its positive or negative state as it passes the quadrant line.

The sine-cosine combination of signals 174 and 176 provides several important advantages in monitoring the position of the volume delivery adjustment mechanism. First, the resolution of each signal 174 and 176 vary significantly relative to the phase of the sinusoidal wave form. For example, the angular resolution of signal 174 is very good at or near the 0° and 180° positions where the signal 174 varies quickly with small changes in rotational position of the volume delivery adjustment mechanism. However, at the 90° and 270° positions, signal 174 no longer changes significantly with the angular rotation of the volume delivery adjustment mechanism. Fortunately, since the signal 176 is 90° out of phase from signal 174, its optimum resolution for detecting rotation of the volume delivery adjustment mechanism occurs at the precise positions where the signal 174 resolution is poor.

Another advantage of the sine-cosine combination of signals 174 and 176 is the ability to determine direction of rotation of the volume delivery adjustment mechanism based on the relative change of signal values from signals 174 and 176. This features also makes it very simple for the electronics assembly 40 to identify and tally all rotations of the volume delivery adjustment mechanism.

An added, and possibly most important advantage of the sine-cosine combination is the ability to discern the difference between a volume delivery adjustment mechanism position in the first 180° of rotation, and the second 180° of rotation. With only a single sinusoidal signal, the repeating waveform would be indistinguishable between a first half and a second half of a full rotation of the volume delivery adjustment mechanism. This is because the sine function is equal at corresponding points between the first and second half of a whole rotation. However, the addition of the second signal allows comparison thereof with the first signal and allows easy identification of the position of the volume delivery adjustment mechanism in each quadrant of its rotation.

Referring again to Figure 19, it can be seen that in the first quadrant of rotation of the volume delivery adjustment mechanism, between 0 and 90°, signal 174 is positive and decreasing while signal 176 is positive and increasing. However, at the 90° position, signal 176 becomes negative, so that the second quadrant, from 90° to 180°, is identifiable by the electronics assembly 40 as being the quadrant in which signal 174 is negative and signal 176 is positive. Similarly, quadrant 3, from 180° to 270° is the only quadrant in which both signals 174 and 176 are negative. Finally, quadrant 4, from 270° to 360° contains a positive signal 174 and a negative signal 176.

At any chosen angular rotational position of the volume delivery adjustment mechanism signals 174 and 176 present a unique combination of signal values to the electronics assembly 40.

The annular magnet 116, which rotates with the volume delivery adjustment mechanism, is the key variable in determining the volume delivery adjustment

which are essential for volume delivery setting determination are the relative position within a revolution of the volume delivery adjustment mechanism, the zero volume position from which the electronics assembly is calibrated to recognize the beginning point of the first revolution of the volume delivery adjustment mechanism, and the number of revolutions which have occurred from that zero position. With these three parameters, the electronics assembly 40 can compute the absolute position of the volume delivery adjustment mechanism, meaning the position in total number of revolutions plus the number of rotational degrees in the last revolution, from the zero position.

The manner in which the pipette 10 of the present invention determines the zero position of the volume delivery adjustment mechanism, and the manner in which the absolute position is calculated to determine the fluid volume delivery setting of the pipette 10, including calibration thereof is detailed below.

20 OPERATION

The pipette 10 of the present invention operates as follows. The operator, using the thumb of the hand holding the pipette 10, presses down on button 72 until the small bushing 78 on the distal end of the plunger 26 touches the primary washer 132. This motion is resisted by the primary spring 32 through the piston adaptor 34. This motion also brings the piston 28 downwardly along the fluid chamber 36. The operator then inserts the distal end of the pipette 10 (with a disposable pipette mounted thereon) into a fluid to be pipetted. The operator releases the button 72 and the primary spring 32 returns to its fully upwardly extended positions, and draws piston 28 in a proximal direction, causing the fluid chamber 36 to be filled with fluid. The operator

container to receive the fluid and again forces button 72 downwardly with the thumb until the small bushing 78 touches the primary washer 56. The user continues downward force on the button 72 to cause the primary washer 132 to also move downwardly against the force of the secondary spring 60 until it is completely compressed. At this point, the preset volume of fluid has been delivered from the fluid channel 36.

If the operator desires to change the fluid volume delivery setting, the operator rotates button 72 either clockwise to reduce the volume delivery setting, or counterclockwise to increase the volume delivery setting. Rotation of button 72 causes rotation of bobber guide 82, threaded advancer 74, transducer drive 76, transducer bearing 130, and the annular magnet 116. Rotation of the thread advancer 74 (by rotation of button 72) causes the threaded advancer 74 to rotate through the threads 140 on the inside of the bushing 70 and thereby move in a longitudinal direction. This longitudinal movement also forces longitudinal movement of the plunger 26 and the transducer driver 76.

Rotational motion of the bobber guide 82, causes the bobber 80 to be forced downwardly in the distal direction against the bobber spring 88 until the bobber switch 84 contacts the stationary switch pad 98. In the preferred embodiment, the gap between the bobber switch 84 and the stationary switch pad 98 is approximately .010 to .0.15 inches. Since the bobber 80 is keyed to the housing 12, and therefore cannot rotate, it moves downward to allow the meshing teeth 148 of the bobber guide 82 to pass over the meshing teeth 146 of the bobber 80 (approximately .030 inches). The individual teeth of the meshing teeth 146 and 148 are preferably sized to cause the bobber 80 to "bob" approximately every 6° of rotation. Each time the bobber is forced

bobber switch 84 is forced into contact with the stationary switch pad 98 (since the gap between them is only approximately .010 to .015 inches, and the downward movement of the bobber switch is approximately .030 inches which exceeds the gap). The bobber spring 88 then forces the bobber 80 upwardly again against the bobber guide 82. When the bobber 80 is again in its upwardmost position, the bobber switch 84 is again spaced away from the stationary switch pad 98. The contact of bobber switch 84 with the stationary switch pad 98 sends an interrupt signal to the microprocessor 110 which it recognizes as a signal to power up the sensors 122 and 124 in the transducer assembly 20.

As the annular magnet 116 rotates, the magnetic field thereof passes through the sensors 122 and 124. The sensors 122 and 124 produce a current output based on the changing magnetic field passing therethrough which is sent to the microprocessor 110 through leads 134 and 136. The microprocessor computes a new volume delivery setting based on the signals it receives from the sensors 122 and 124 and displays the new volume setting in display 112.

When the operator stops turning the knob 72, the bobber 80 is again biased to its upward proximal position by the bobber spring 88, and the bobber switch 84 is separated from the stationary switch pad 98. After a short period of time, preferably approximately 100 milliseconds after receiving its last interrupt signal, the microprocessor 110 turns off the power to the transducer assembly 20. The display 112 however remains powered, and continuously displays the current fluid delivery setting. In this manner, when the pipette 10 is not activated to change a fluid delivery setting, the power consumption thereof is limited to the power required to maintain the current fluid delivery

microamps). The high power requirements of the transducer assembly 20. (Approximately 170 milliamps) are only being consumed therefor when the pipette 10 is actually being operated to change its fluid volume delivery setting.

Operation of the pipette 10 of the present invention when used with the multi channel barrel assembly 158 is identical to that described above with respect to the single channel barrel assembly 30.

When it is desired to clean the pipette 10, the user merely removes the nut 128 from the ejector rod 18 and slides the ejector barrel 66 off of the barrel assembly 30. The barrel assembly 30 is then removed by rotating the barrel housing 42 thereof, with respect to the pipette housing 12 until it is disengaged from the threads of the bushing barrel 64.

The multi channel barrel assembly 158 is removed from the remainder of the pipette 10 by merely rotating the lock nut 170 with respect to the adaptor 171. There is however, no need to disengage the ejector assembly 160 therefrom, since it is not itself attached directly to the remainder of the pipette 10, or the ejector rod 18.

The electronics assembly 40 both conditions and processes the signals 174 and 176 from the transducer assembly 20. Both transducer signals 174 and 176 feed into a comparator circuit and into the A/D convertor of the microprocessor 110. The comparator circuit of the microprocessor 110 is designed to switch at approximately the midpoint of each of the transducer signals 174 and 176 in the manner known in the art. This allows the signals 174 and 176 to be viewed as square wave signals each having a positive or negative value. In this manner, the microprocessor 110 determines in which quadrant the volume delivery

Figure 19, if both values are positive, the first quadrant is indicated. A positive value for signal 174 and negative value for signal 176 indicates the second quadrant. Two negative values indicate the third quadrant, and a positive value for signal 176 and a negative value for signal 174 indicates the fourth quadrant.

The A/D converter of the microprocessor 110 also allows measurement of the actual voltage of each signal 174 and 176.

In the preferred embodiment of the present invention, the microprocessor 110 contains a calibration map which is programmed therein prior to use. The calibration map includes a complete set of signal values corresponding to the values of signals 174 and 176 at each position of the magnet 116 relative to the sensors 122 and 124. The present value of signals 174 and 176 is compared to the calibration map to determine the rotational position of the volume delivery adjustment mechanism, and thereafter, the fluid volume delivery setting.

The calibration map is developed by rotating the volume delivery adjustment mechanism through one entire revolution and recording and storing each pair of signal values from signals 174 and 176 at predetermined evenly spaced 6° increments between 0° and 360°. Figure 20 shows how the calibration map is generated. Initially, the pipette 10 is attached to a calibration fixture (not shown) which requires it to read the signal values for signals 174 and 176. The calibration fixture then stores these signal values and checks to see if it has received sixty pairs of signal values. If not, the fixture rotates the button 72 six degrees (corresponding to one "bob" of the bobber 80) and reads the signal values for signals 174 and 176 in this new position.

The fixture again stores the signal values as a pair and checks to see if all sixty points have been measured.

Once sixty pairs of signal values have been stored by the fixture, the fixture will repeat the entire
5 process to develop two complete sets of data.

Next, the data is checked to ensure that the values received from signals 174 and 176 both correspond to a sinusoidally shaped curve and that the range for each signal 174 and 176 is equivalent.

10 If the validation is successful, the set of data corresponding most accurately to a sinusoidal shaped curve and the desired range equivalency becomes the calibration map, and is stored in the microprocessor 110 and the calibration is completed. Since the sign,
15 positive or negative, of each value is also collected and stored as part of the calibration map, the relative position within a revolution of the volume delivery adjustment mechanism can be determined at any time by comparing the present values of signals 174 and 176
20 being received by the microprocessor 110, with the calibration map. This is the first step in computing the absolute position of the volume delivery adjustment mechanism.

An alternative approach to computing the relative
25 position of the volume delivery adjustment mechanism includes the use of algorithms preprogrammed into the microprocessor 110. In this embodiment, the present relative position of the volume delivery adjustment mechanism, described in degrees of rotation, may be
30 determined by the algorithm:

$$\text{rel POS} = (\text{slope} \times A) \div 256 + \text{offset}$$

Where:

rel POS is the relative position

Slope is the slope of the linear curve bit for the
35 sinusoidal quadrant that the volume delivery adjustment

A is the A/D value for the sensor 160 or 162 used in the sinusoidal quadrant in which the volume delivery adjustment mechanism is presently positioned.

Offset is the "y" intercept of the linear curve bit
5 for the sinusoidal quadrant.

256 is the scale factor built into the slope.

Once the relative position is computed, either by using the calibration map or the algorithm method, the zero volume position, or zero position, must then
10 established. The zero position is defined as the relative position of the volume delivery adjustment mechanism in a particular revolution which corresponds to a zero fluid volume delivery setting. The zero
15 position of the volume delivery adjustment mechanism is easily obtained. First, the user rotates the button 72 clockwise until the threads 138 of advancer 74 are completely threaded into the threads 140 of bushing 70, and the bushing 78 touches the primary washer 56. The
20 user then presses the calibration button 114, the "zero" button, which causes the display 112 to read a zero volume setting. Also, the microprocessor 110 stores the signal values, including the quadrant information and identifies this information as the zero position of the
25 volume delivery adjustment mechanism. In this way, any later setting of the volume delivery adjustment
mechanism to any relative position is normalized with respect to the zero position in order to determine the total rotation of the volume delivery adjustment mechanism away from the zero position.

30 There are two cases for normalization. The first case is when the relative position is greater than the zero position in any particular revolution. In this case, the normalized position is determined by subtracting the zero position from the relative
35 position. The second case of course describes the

the zero position in any particular revolution. In this case, the normalized position is determined by subtracting the zero position from the relative position and then adding 360° (one full revolution).

5 The quadrant information, which includes the positive or negative sign on the signals 174 and 176, is monitored by the microprocessor 110 each time the interrupt from the microswitch assembly 50 occurs. Each time the volume delivery adjustment mechanism rotates
10 far enough to return to the quadrant containing the zero position, one revolution is completed and that revolution is counted by the microprocessor 110. This revolution is added to the total revolution count maintained by the microprocessor 110 if the quadrant
15 information received by the microprocessor 110 indicates that the volume delivery adjustment mechanism was being rotated in the counterclockwise direction (which increases the fluid volume delivery setting), or subtracts one revolution if it determines that the
20 volume delivery adjustment mechanism rotated into the zero quadrant from the opposite direction.

Because the zero position will not usually occur on a quadrant boundary, there is a chance that the revolution count may be incremented before the real zero
25 position is actually reached. In this cases, the revolution count must be decreased by one revolution before it is used to compute the fluid volume delivery setting. In this instance, the microprocessor 110 checks the four quadrant positions under which this
30 could occur and appropriately adjust the revolution count.

By knowing the normalized position and revolution count of the volume delivery adjustment mechanism, the electronics assembly 40 can compute its absolute
35 position as follows:

Where POS A is the absolute position from the zero position in any revolution of the volume delivery adjustment mechanism.

Revs is the revolution count.

5 POS N is the normalized position within the revolution.

If the absolute position is within the range for the pipette 10, the fluid volume delivery setting is computed and displayed. If not, an error message is
10 displayed.

Computation of the fluid volume delivery setting is accomplished by multiplying the volume per revolution by the number of revolutions (and partial revolution) of the volume delivery adjustment mechanism from the zero
15 position.

The actual fluid volume delivery setting corresponding to a valid absolute position depends of course on the volume displacement of the piston for each revolution of the volume delivery adjustment mechanism.
20 This is controlled by the pitch of the threads 138 and 140 of the advancer 74 and bushing 70 respectively, and the diameter of the piston 28. In the preferred embodiment of the invention, the pitch of the threads 138 and 140 is preferably approximately 28 threads per
25 inch. The diameter of the advancer 74 and bushing 70 which hold the threads 138 and 140 respectively is preferably 5/8 of an inch. In the preferred embodiment of the invention the diameter of the advancer 74 and bushing 70 is held constant, and the diameter of the
30 piston 28 is changed in order to change the delivery range of the pipette 10. For example, the preferred embodiment of the pipette 10, in which the delivery range is between .5 and 10 microliters is .0315 inches. For a pipette 10 having a delivery range between 2 and
35 20 microliters, the diameter of the piston 28 is

100 microliters, the diameter of piston 28 is preferably .0995 inches. For a delivery range of between 20 and 200 microliters, the diameter of the piston 28 is preferably .1440 inches. For a delivery range between 5 100 and 1000 microliters, the diameter of the piston 28 is preferably .3160 inches.

For each delivery range desired by the pipette 10, the preferred diameter of the piston 28 is used therein, and the microprocessor 110 is programmed with the chosen 10 diameter. Since the threads 138 and 140 of the advancer 74 and bushing 70 respectively remain at the same pitch regardless of the diameter change of the piston 28, the microprocessor 110 can directly compute fluid volumes drawn and delivered for any desired delivery range based 15 on the above described calibration mapping or algorithm software without modification thereof, as long as the diameter of the piston 28 is specified to the microprocessor 110.

Once the fluid volume delivery setting is computed 20 and displayed, the user can then turn the knob 72 until the desired fluid volume delivery setting is present in the display 112. When the user stops turning the knob 72, the bobber 80 is again biased to its upward proximal position by the bobber spring 88, and the bobber switch 25 84 is separated from the stationary switch pad 98. After a short period of time, preferably approximately 100 milliseconds after receiving its last interrupt signal, the microprocessor 110 turns off the power to the transducer assembly 20. The display 112 however 30 remains powered, and continuously displays the current fluid delivery setting. In this manner, when the pipette 10 is not activated to change a fluid delivery setting, the power consumption thereof is limited to the power required to maintain the current fluid delivery 35 setting displayed on the display 112 (approximately 10

transducer assembly 20 (approximately 17.0 milliamps) are only being consumed therefor when the pipette 10 is actually being operated to change its fluid volume delivery setting.

5 Once the user has chosen a desired fluid flow delivery setting, the user can thereafter check the accuracy of the setting and further calibrate the pipette 10 to be completely accurate on its delivery at the chosen fluid volume delivery setting. To do this,
10 the user performs an accuracy check on the actual volume of fluid being delivered at the fluid volume delivery setting. The user first draws water into the pipette tip in the above desired manner and then dispenses the water onto a scale. The weight of the water actually
15 dispensed by the pipette 10 is then obtained from the scale and compared to the fluid volume delivery setting being displayed on the display 112. Since there is a one to one correspondence between the weight of water in grams and the volume of water in milliliters, the user
20 can readily identify the exact volume of water which was delivered by the pipette 10. If the display 112 is showing a slightly different fluid volume delivery setting, the user adjusts the display by pushing either one of the calibration buttons 113 or 115 to move the
25 display reading either up or down as required to match the display with the actual fluid volume delivered.

It should be noted that calibration at a particular point of use to ensure exact correlation between the actual fluid volume delivered and the fluid volume
30 delivery setting being displayed on display 112 effects only the number being displayed by display 112. The point calibration operation does not change any calibration settings of the microprocessor 110 nor any mechanical settings of the pipette 10.

35 An alternative embodiment of the microswitch

21. In this embodiment, the bobber switch 84 and stationary switch pad 98 are replaced with bobber groove 178 and switch button 180 respectively. When the bobber 80 is in its upwardly biased position, switch button 180 rests in bobber groove 178. However, when the bobber is forced downwardly by rotation of bobber guide 82, the bobber groove 178 also moves downwardly. The switch button 180 is forced out of the bobber groove 178 and into switch box 182 to make electrical contact with the circuit of the electronic volume monitoring system and send its interrupt signal to the microprocessor 110.

It will be apparent from the foregoing that, while particular embodiments of the invention have been illustrated and described, various modifications can be made thereto without departing from the spirit and scope of the invention. Specifically, for example, the preferred embodiment of the monitoring assembly of the present invention is shown and described as a transducer assembly including Hall-effect sensors. However, any monitoring assembly, such as an optical encoder which will provide a pulse at known angular intervals, is also contemplated by the present invention. Accordingly, it is not intended that the invention be limited, except as by the appended claims.

CLAIMS

1. A pipette for delivering a predetermined volume of fluid therefrom, said pipette comprising:

a volume delivery adjustment mechanism,

5 a monitoring assembly for producing at least one monitoring signal related to the rotational motion of at least a portion of said volume delivery adjustment mechanism relative to said pipette,

an electronics assembly for computing and
10 displaying a fluid volume delivery setting based on said at least one monitoring signal from said monitoring assembly, and

a microswitch assembly for detecting relative rotational motion between said pipette and said at least
15 a portion of said volume delivery adjustment mechanism and for providing a microswitch signal to said electronics assembly.

2. A pipette according to claim 1 wherein said
20 microswitch signal is an interrupt signal sent to a microprocessor in said electronic assembly.

3. A pipette according to claim 1 wherein said
microswitch signal from said microswitch assembly causes
said electronic assembly to supply power to said
25 monitoring assembly.

4. A pipette according to claim 3 wherein said
electronic assembly automatically stops supplying power
to said monitoring assembly after the passing of a
predetermined time interval after receiving said
30 microswitch signal.

5. A pipettor according to claim 1 wherein said

bobber and a bobber guide, and wherein rotational motion imparted to said bobber guide by said at least a portion of said volume delivery adjustment mechanism imparts linear motion to said bobber, and said linear motion of
5 said bobber causes said microswitch to generate said microswitch signal.

6. A pipette according to claim 5 wherein said bobber and said bobber guide include engaging
10 intermeshing teeth, and said rotational motion of said bobber guide causes said intermeshed teeth to disengage.

7. A pipette according to claim 1 wherein said monitoring assembly is a transducer assembly and said
15 monitoring signal is a transducer signal.

8. A pipette according to claim 7 wherein said transducer assembly produces at least two transducer signals related to the rotational motion of at least a portion of said volume delivery adjustment mechanism
20 relative to said pipette.

9. A pipette according to claim 8 wherein said at least two transducer signals are generated by at least two Hall-effect sensors.

10. A pipette according to claim 9 wherein said at
25 least two Hall-effect sensors are positioned in said transducer assembly 90 rotational degrees from each other.

11. A pipette according to claim 8 wherein said transducer assembly includes an annular magnet which is
30 fixed for rotation with said volume delivery adjustment mechanism, said annular magnet having a diametrically

12. A pipette according to claim 8 wherein said at least two transducer signals include at least two sinusoidal signals which are 90° out of phase from each other.

5 13. A pipette according to claim 8 wherein said transducer signals also relate to the direction of rotational motion of said at least a portion of said volume delivery adjustment mechanism relative to said pipette.

10 14. A pipette according to claim 1 further including a detachable barrel assembly comprising:
a barrel housing, said housing including means for removable attachment thereof to said pipette,
said barrel housing further including at least one
15 channel extending therefrom and at least one piston positioned at least partially within said housing and within said at least one channel for linear movement therein; and
said detachable barrel assembly further including
20 means for holding said piston and said channel in predetermined relative positions with respect to said housing when said detachable barrel assembly is detached from said pipette.

25 15. A pipette according to claim 14 wherein said barrel housing further includes at least one spring therein for biasing said at least one piston relative to said at least one channel.

30 16. A pipette according to claim 14 wherein said barrel housing includes a plurality of pistons and channels.

17. A pipette according to claim 1 further including a calibration system having an electrical assembly which monitors a volume delivery adjustment mechanism, said calibration system comprising:

- 5 a volume delivery adjustment mechanism,
 a transducer assembly for producing at least two transducer signals related to the rotational motion of at least a portion of said volume delivery adjustment mechanism,
- 10 an electronics assembly for receiving said at least two signals from said transducer assembly, said electronics assembly including a calibration map for computing a volume delivery setting based on said at least two signals from said transducer assembly, and
- 15 a display for displaying the computed fluid volume delivery setting.

18. A pipette according to claim 17 wherein said at least two signals from said transducer assembly are sinusoidal signals which are 90° out of phase from each other.

19. A pipette according to claim 17 wherein said at least two transducer signals also relate to the direction of rotational motion of said at least a portion of said volume delivery adjustment mechanism.

- 5 20. A pipette according to claim 17 wherein said display can be adjusted to change the displayed fluid volume delivery setting without otherwise effecting said electronics assembly or said calibration map.

1/17

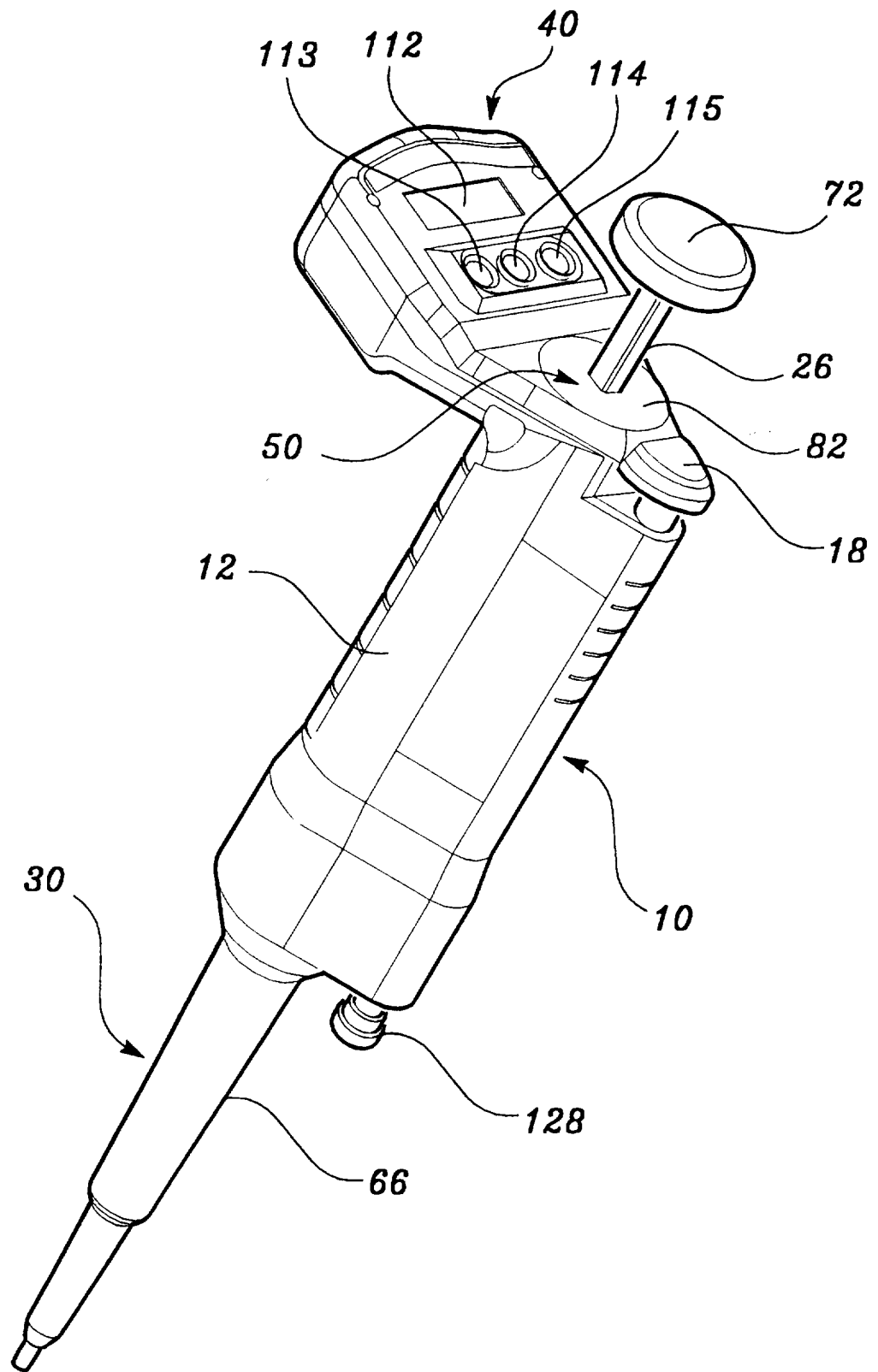

figure 1

SUBSTITUTE SHEET (RULE 26)

2/17

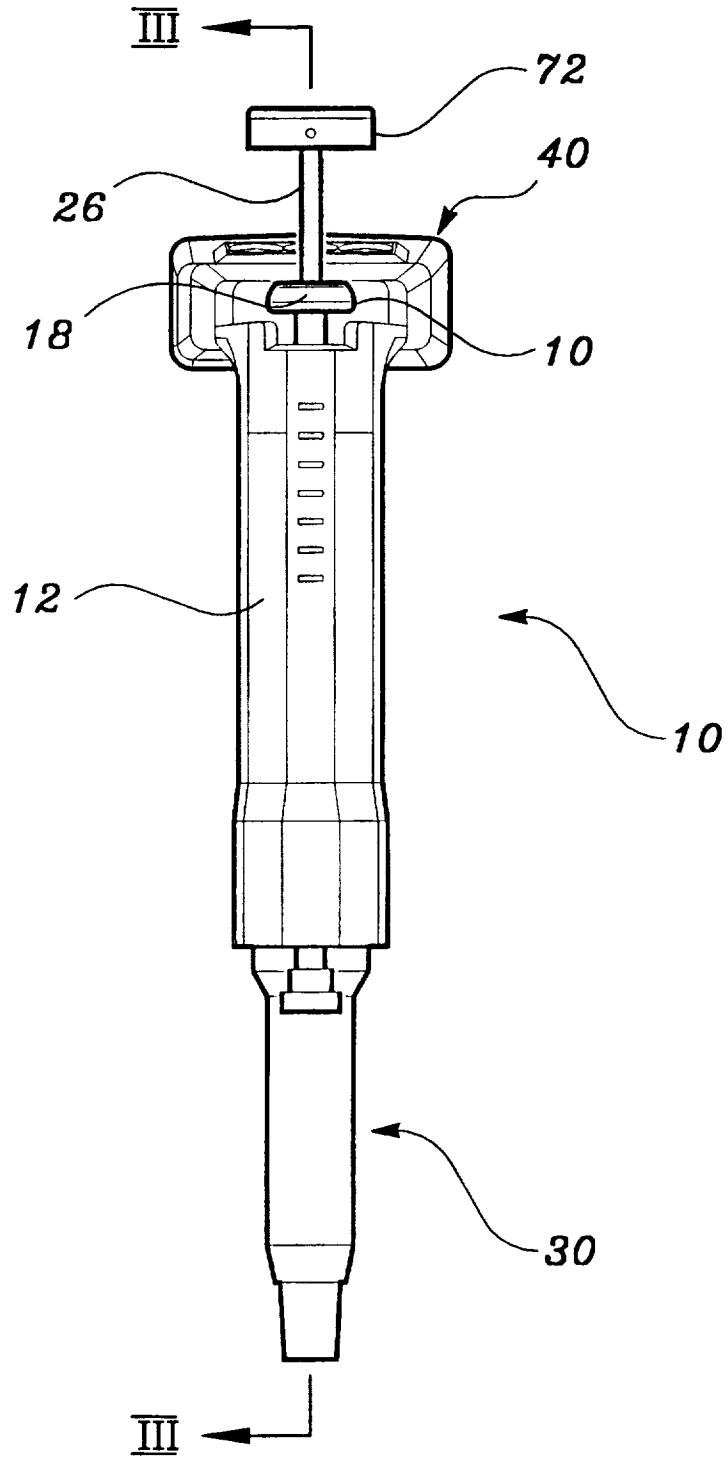

FIG. 2

3/17

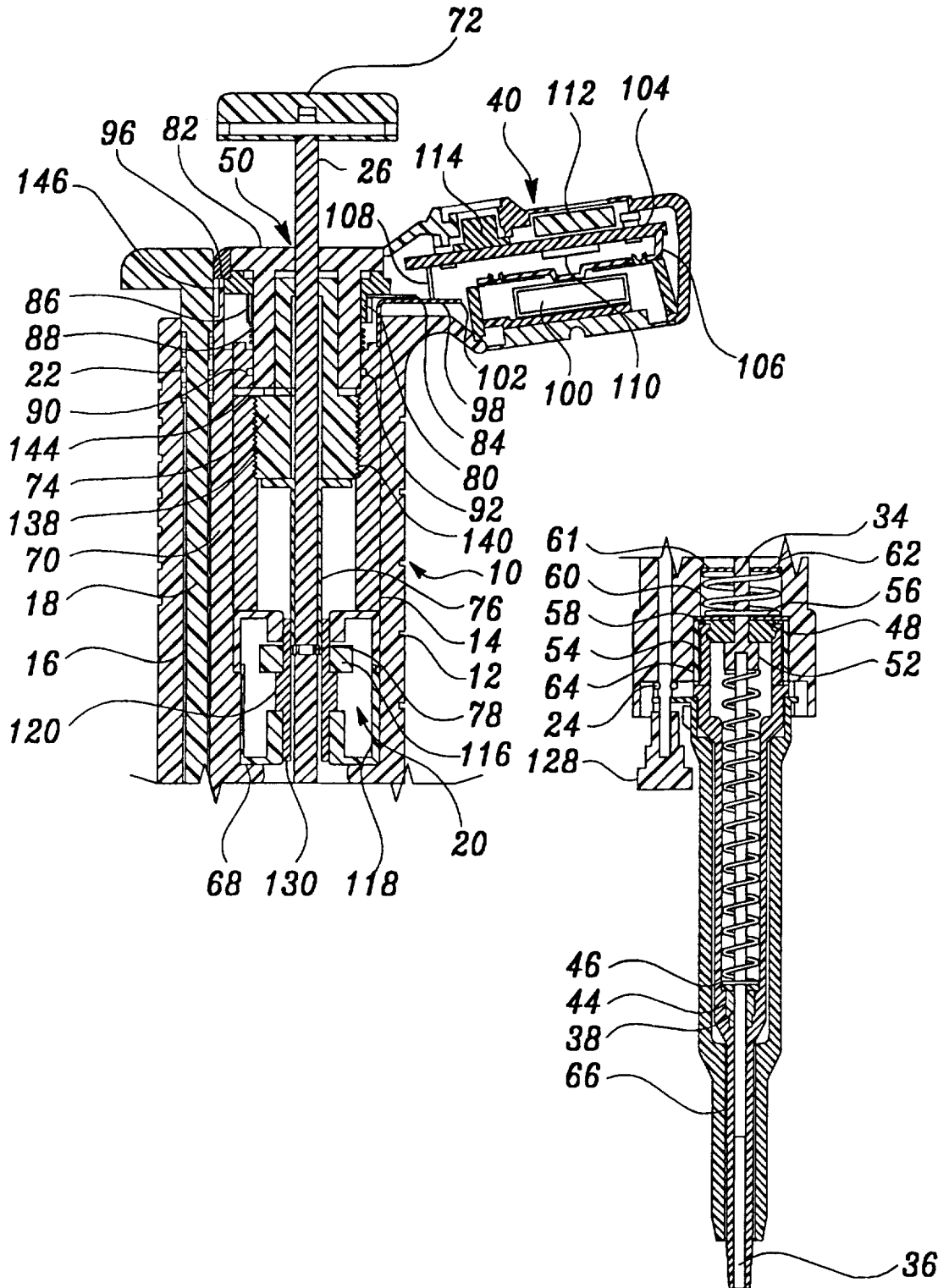

figure 3

SUBSTITUTE SHEET (RULE 26)

4/17

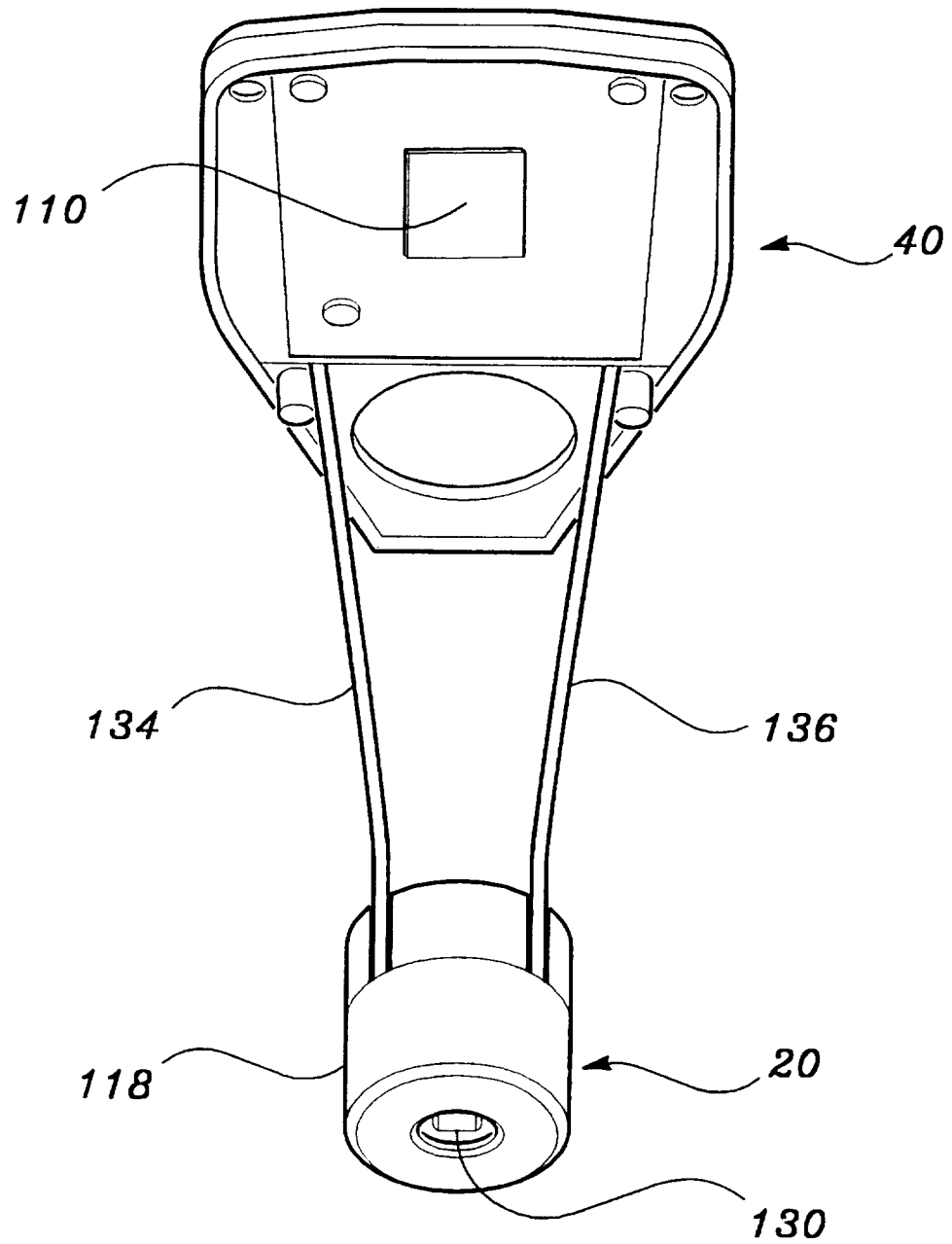

FIG. 4

SUBSTITUTE SHEET (RULE 26)

5/17

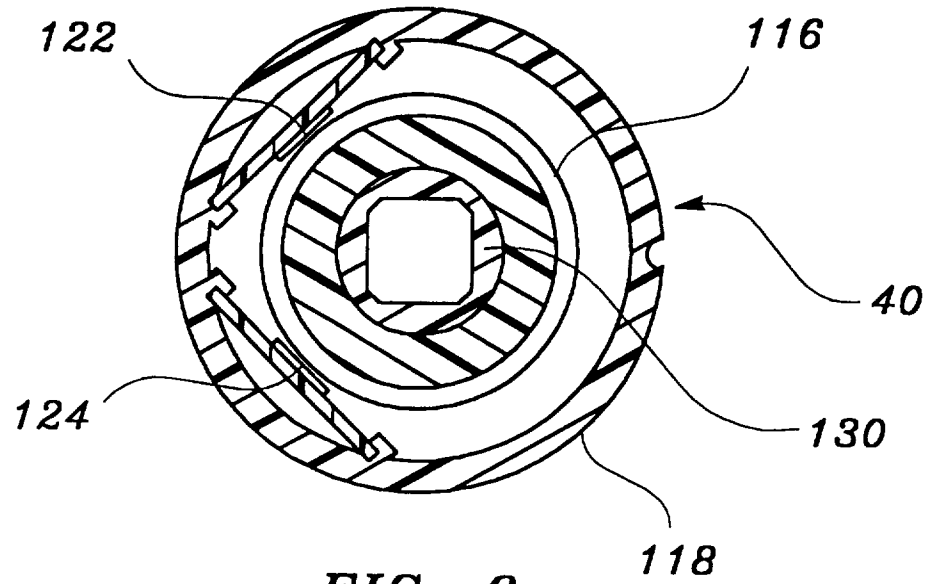

FIG. 6

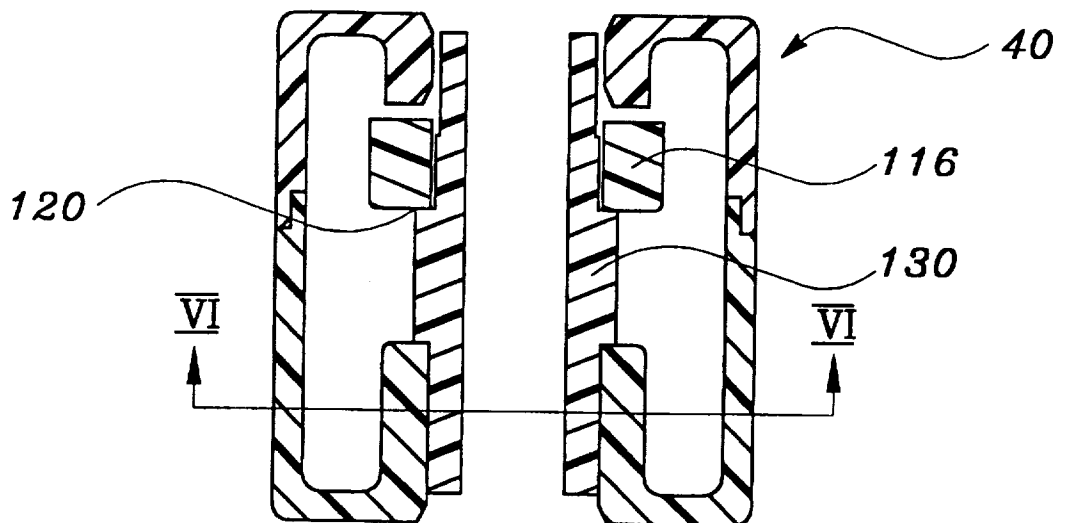

FIG. 5

SUBSTITUTE SHEET (RULE 26)

6/17

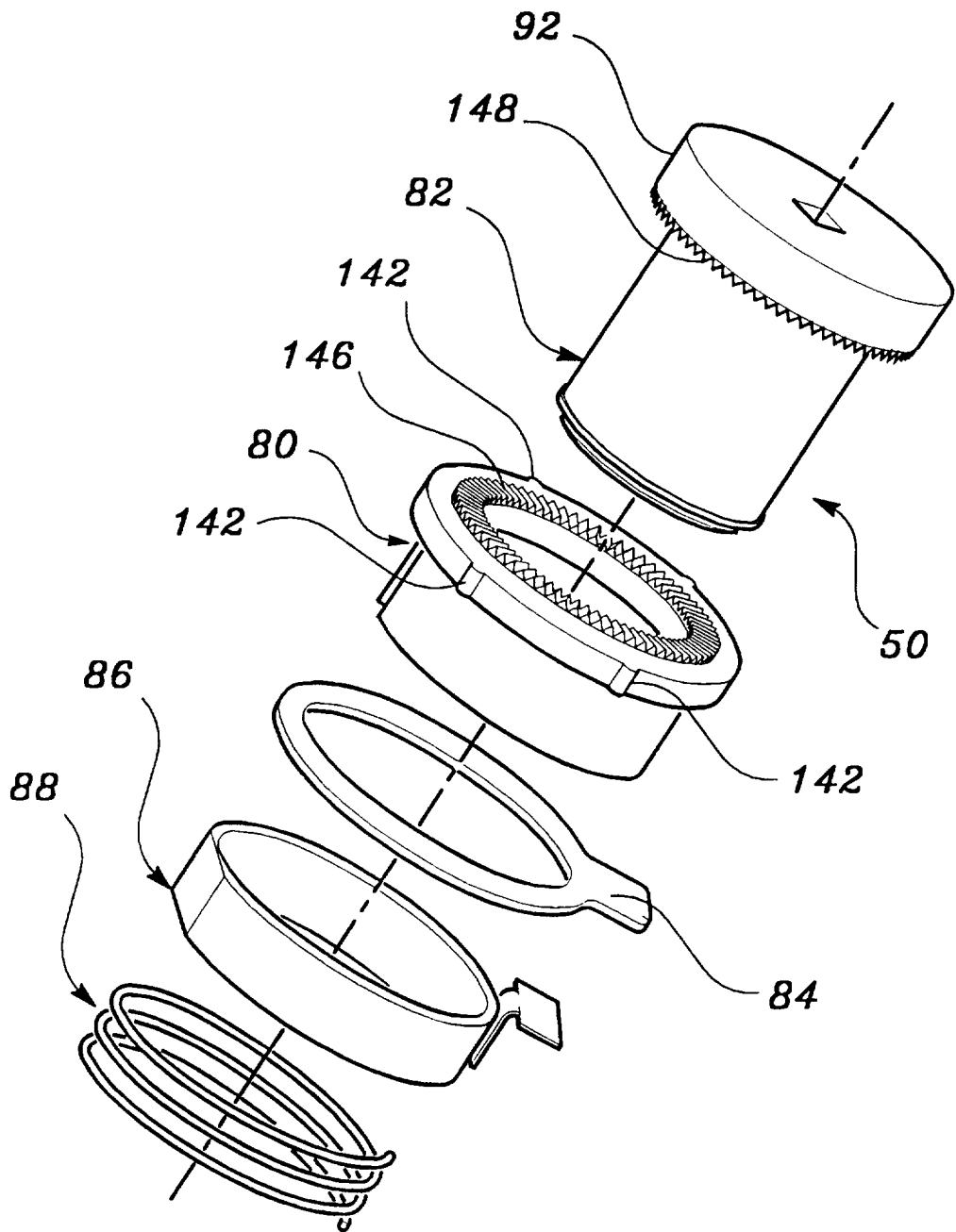

FIG. 7

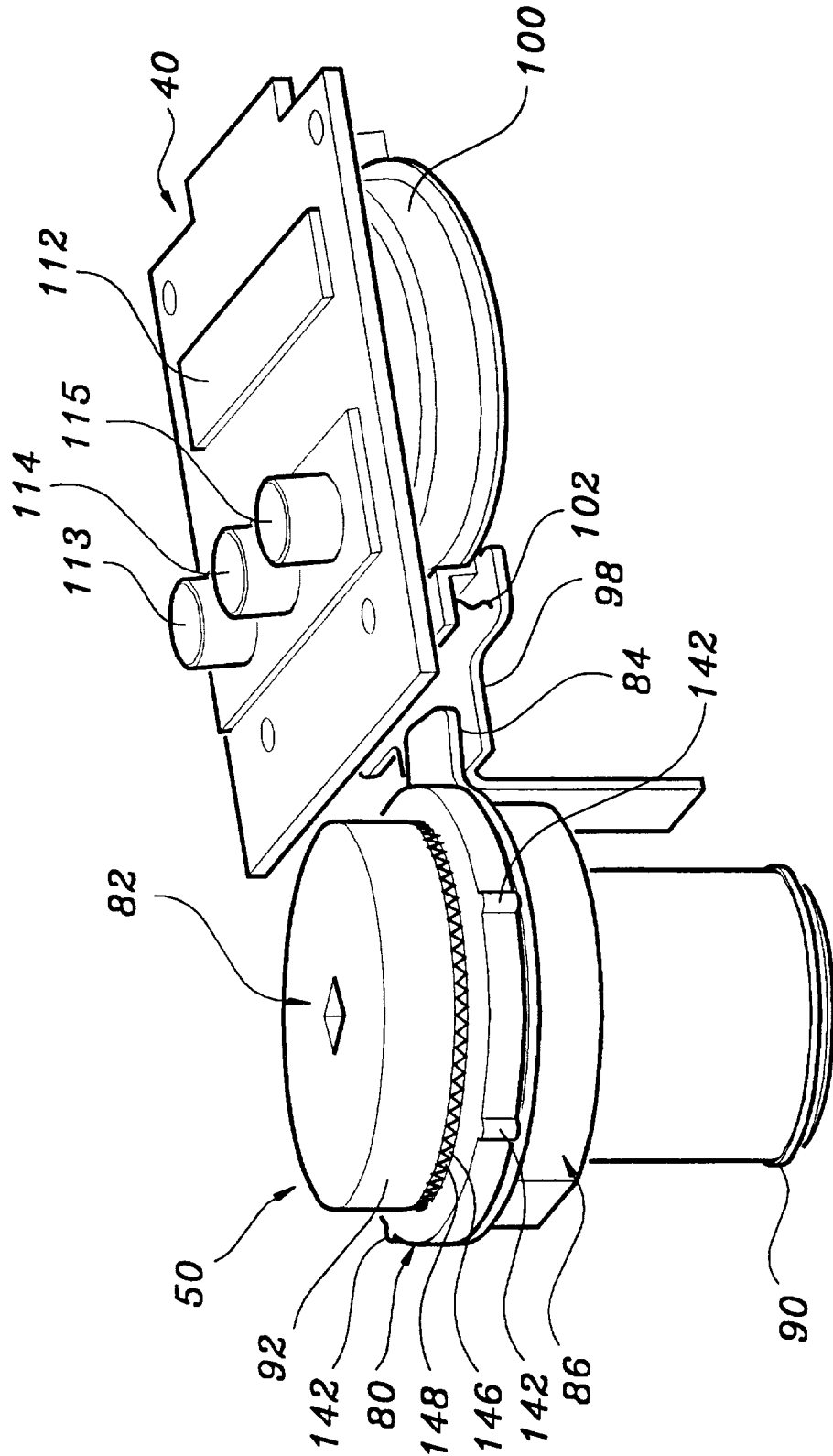

Fig. 8

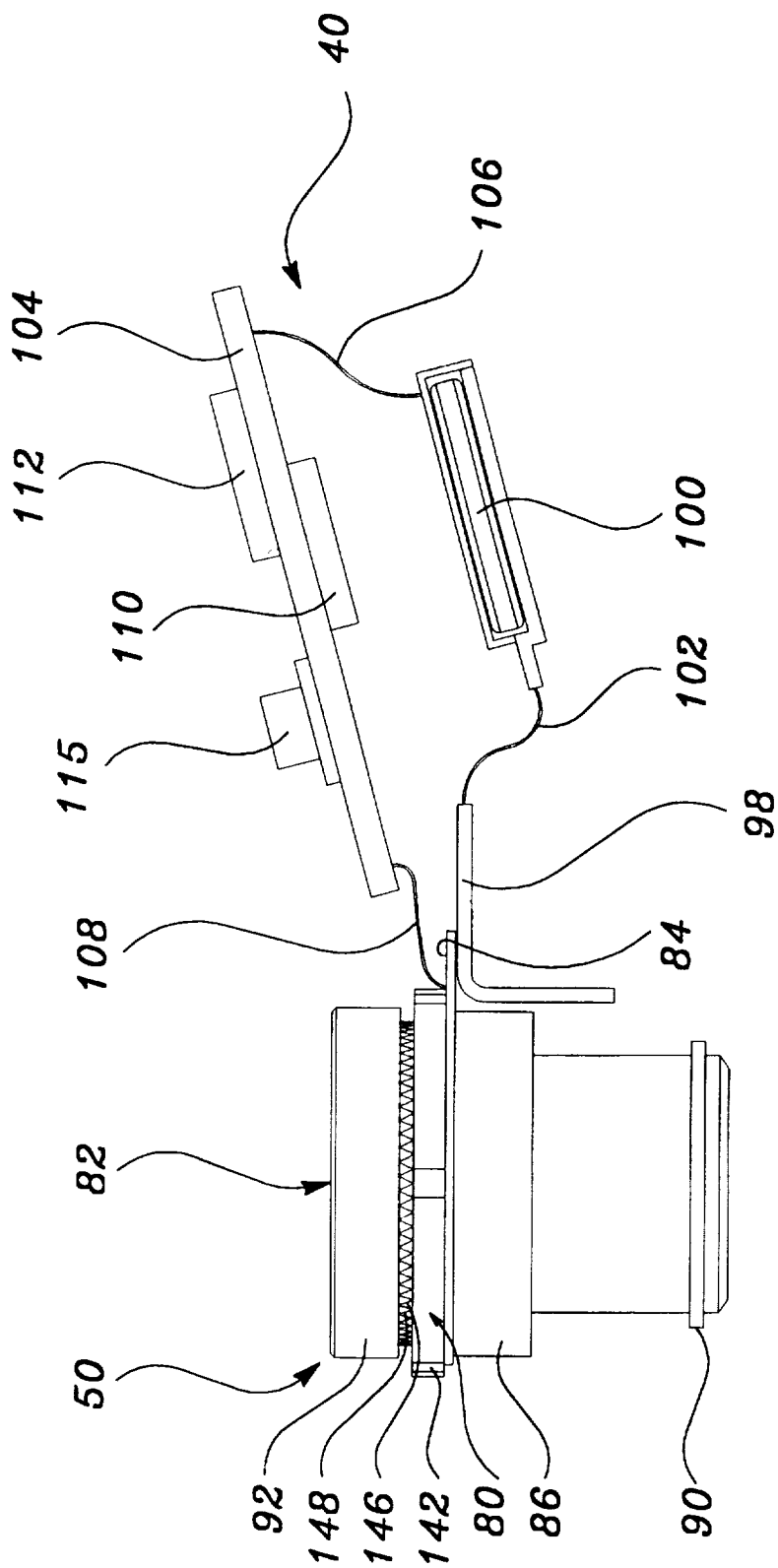

Fig. 9

9/17

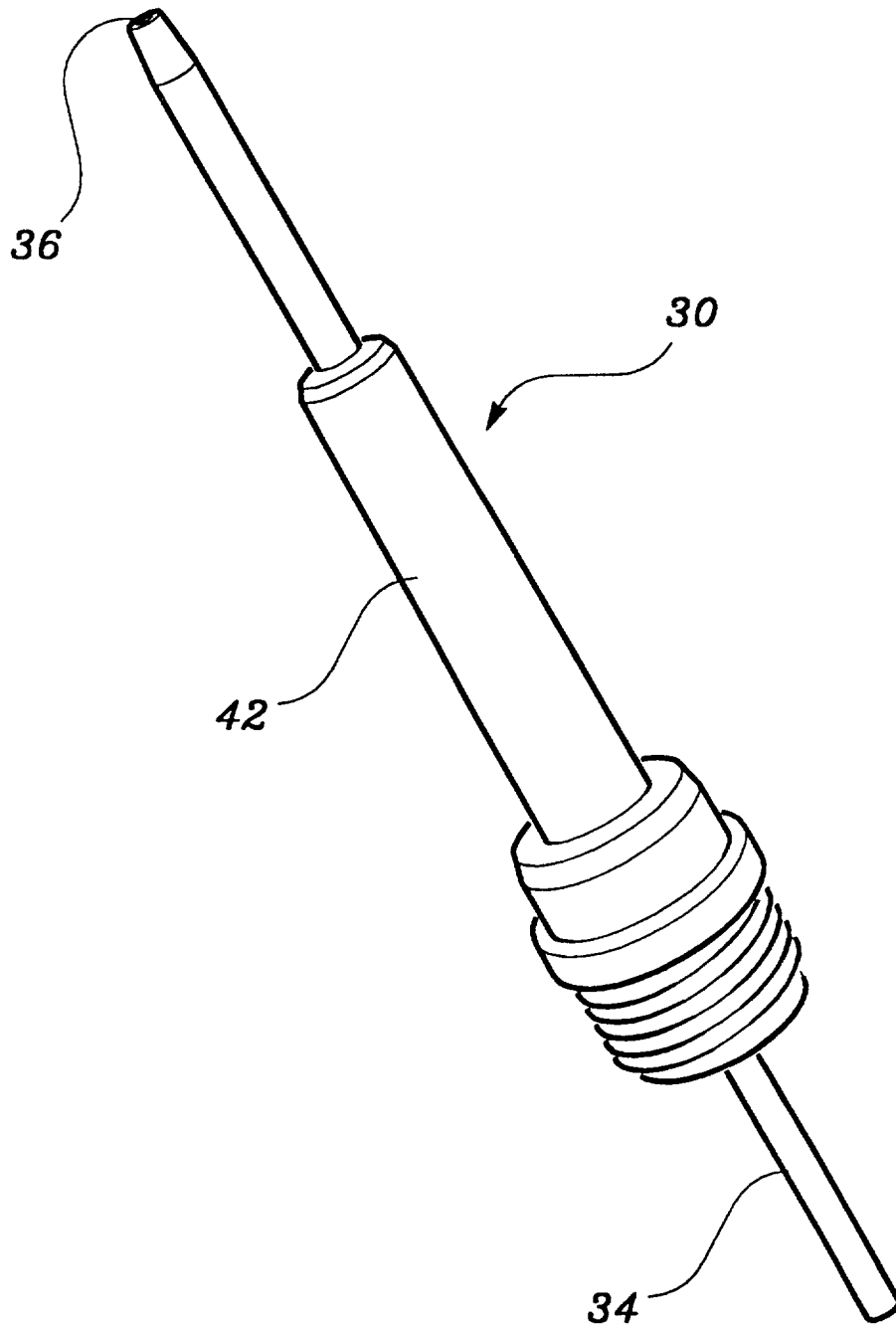

figure 10

SUBSTITUTE SHEET (RULE 26)

10/17

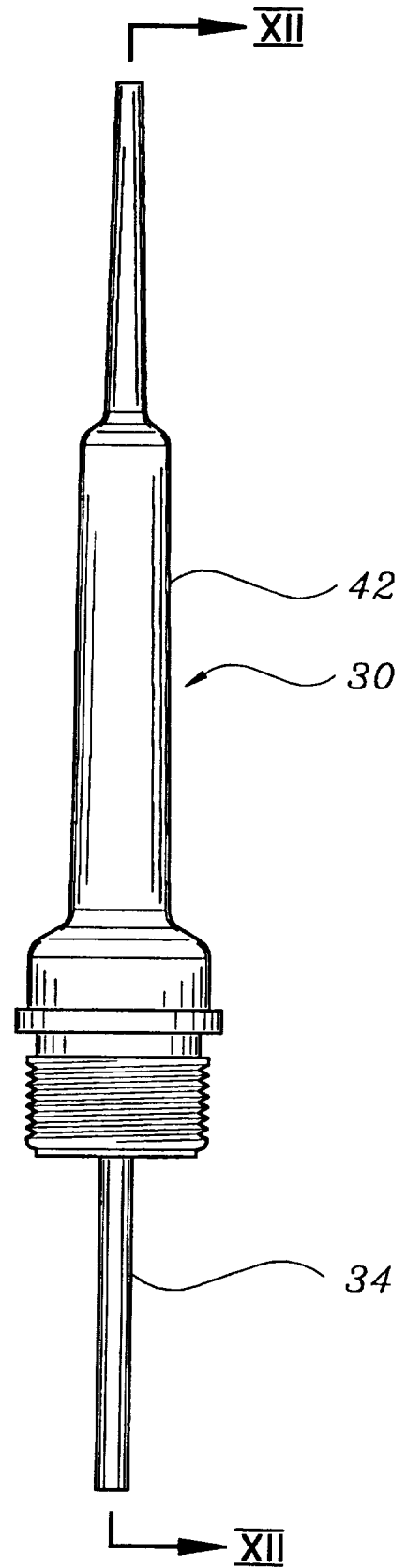
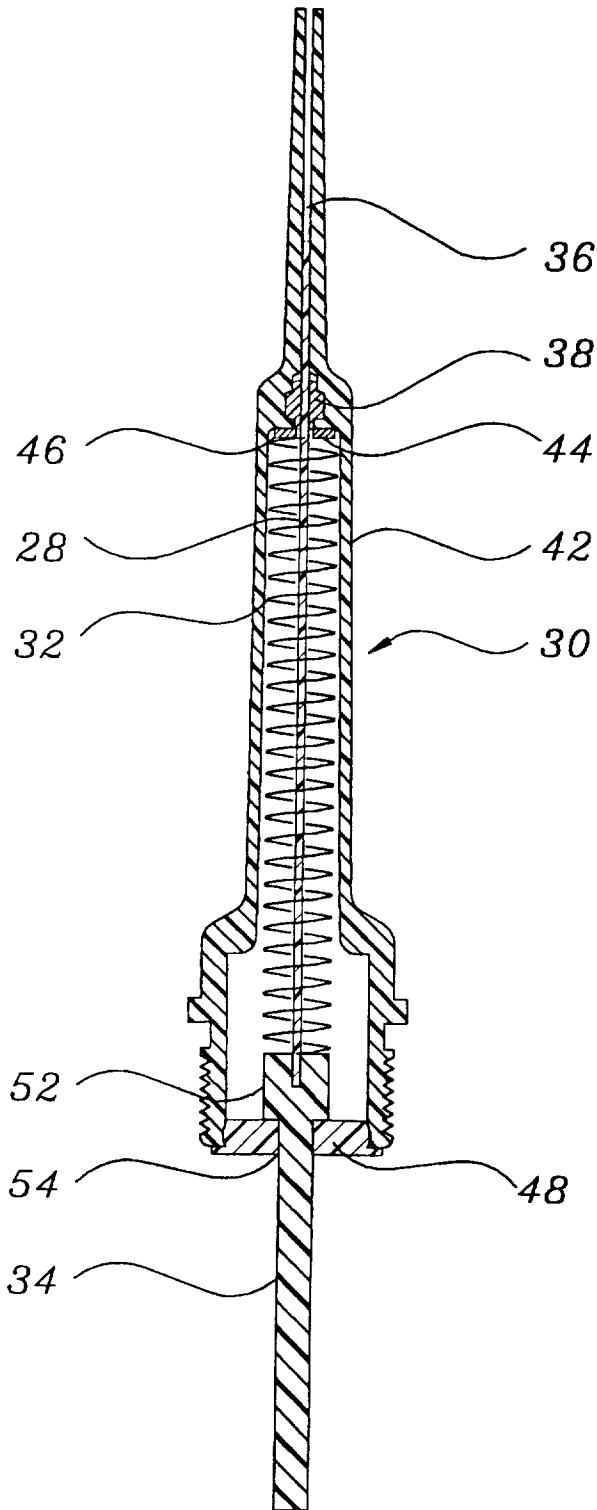

Figure 12

Figure 11

11/17

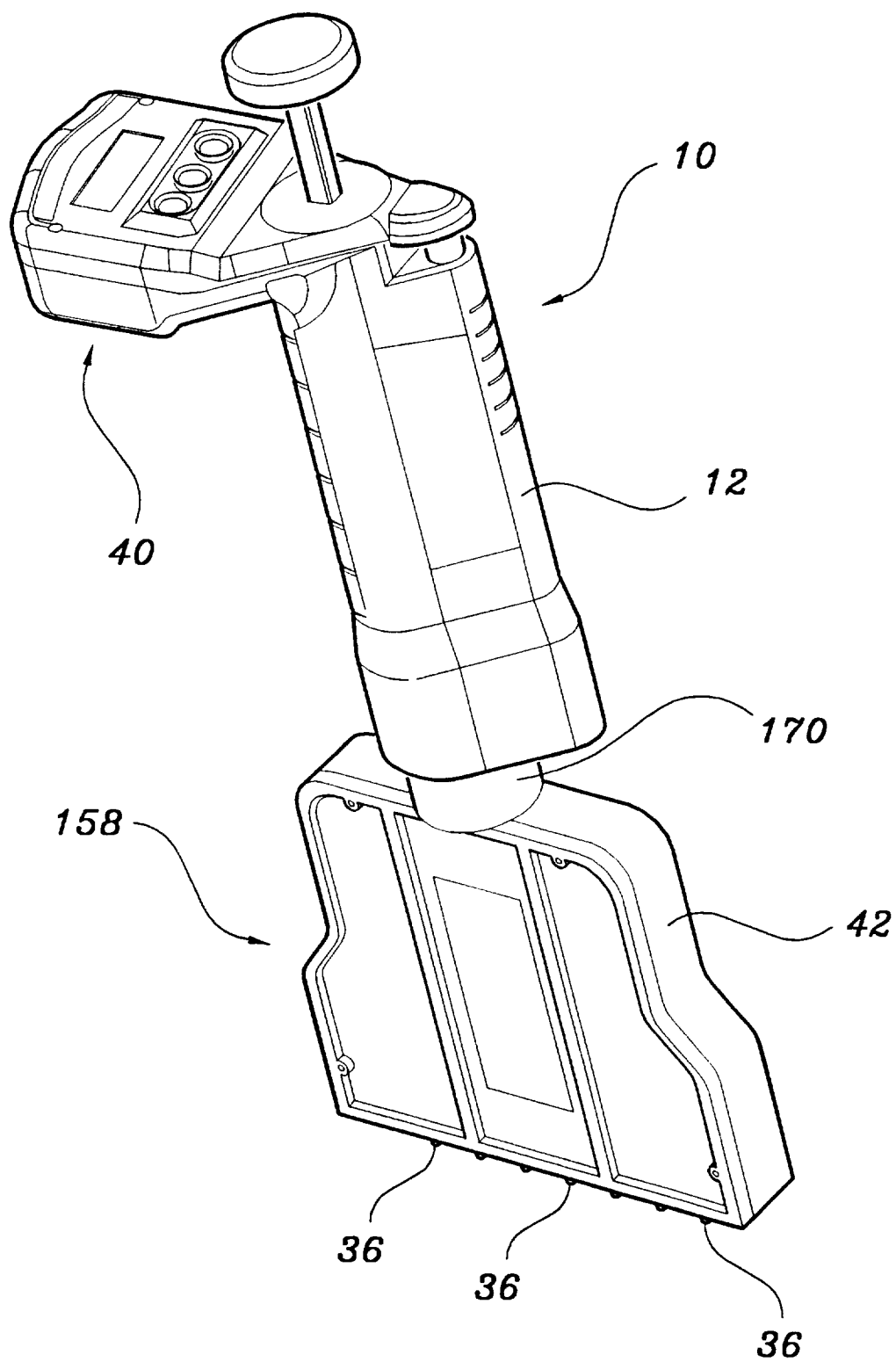

figure 13

12/17

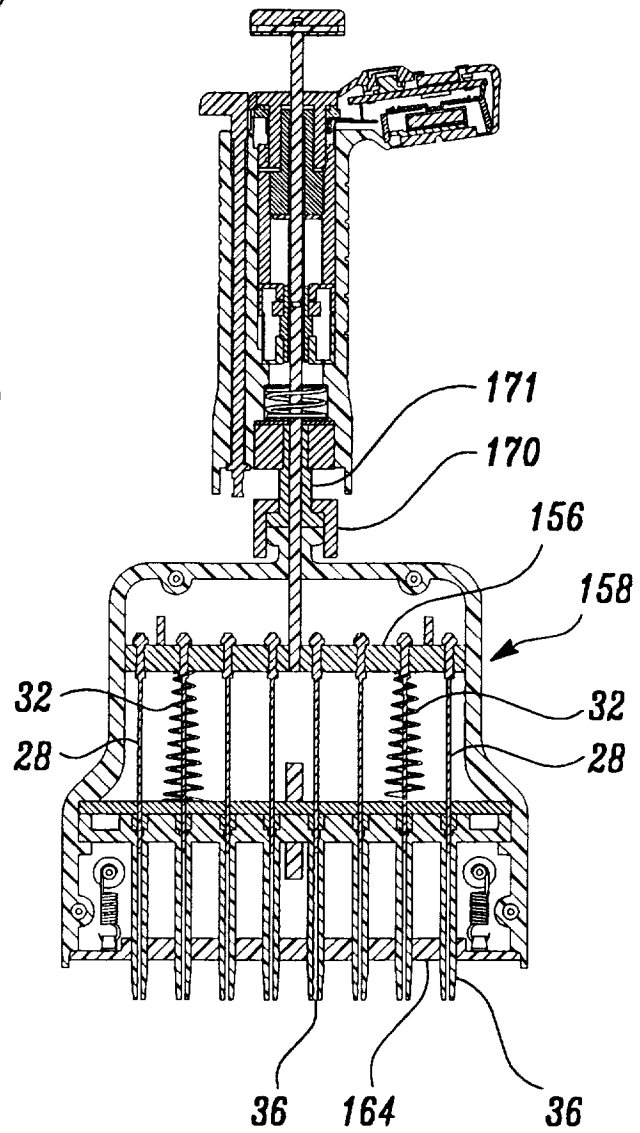
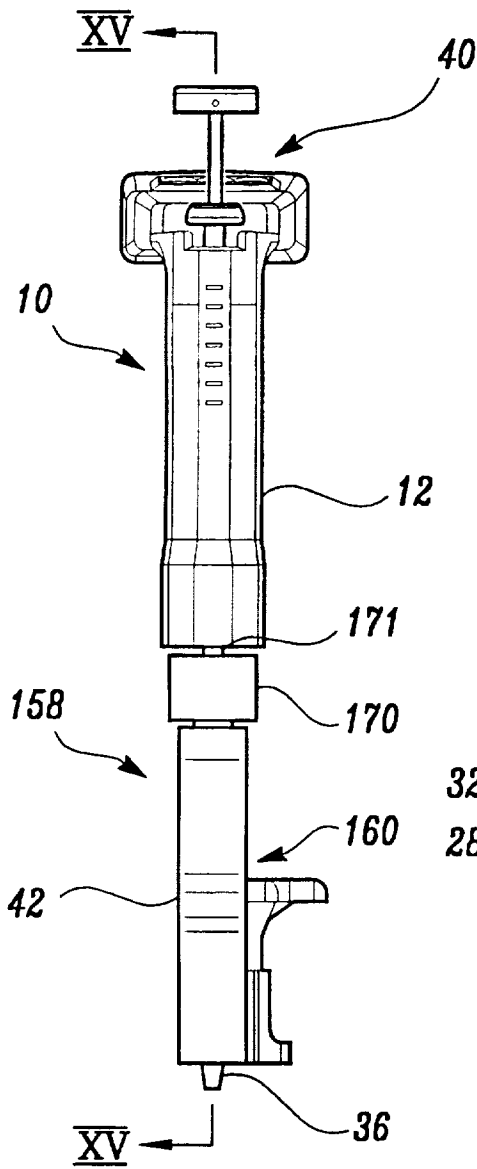

figure 14

figure 15

13/17

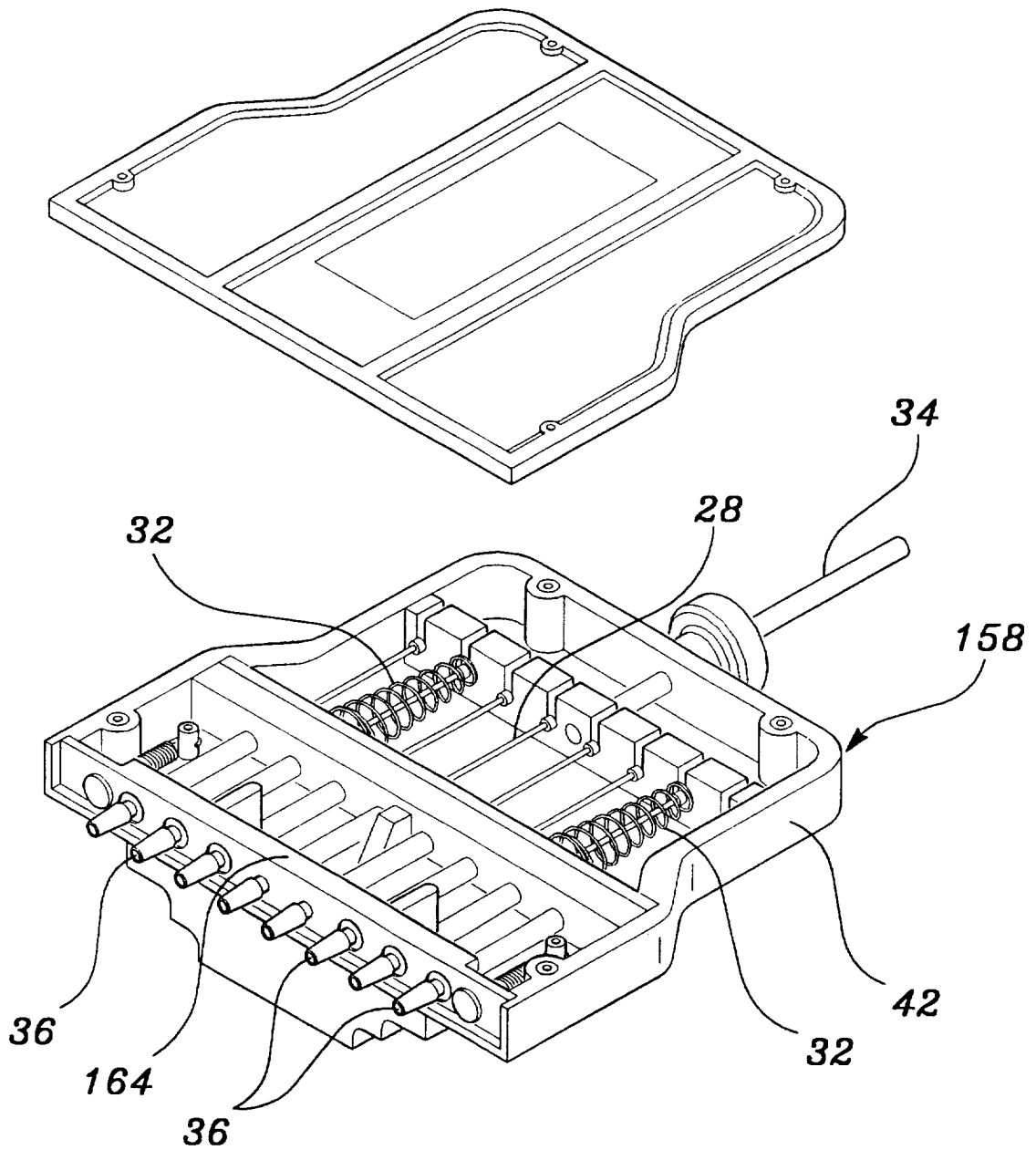

figure 16

SUBSTITUTE SHEET (RULE 26)

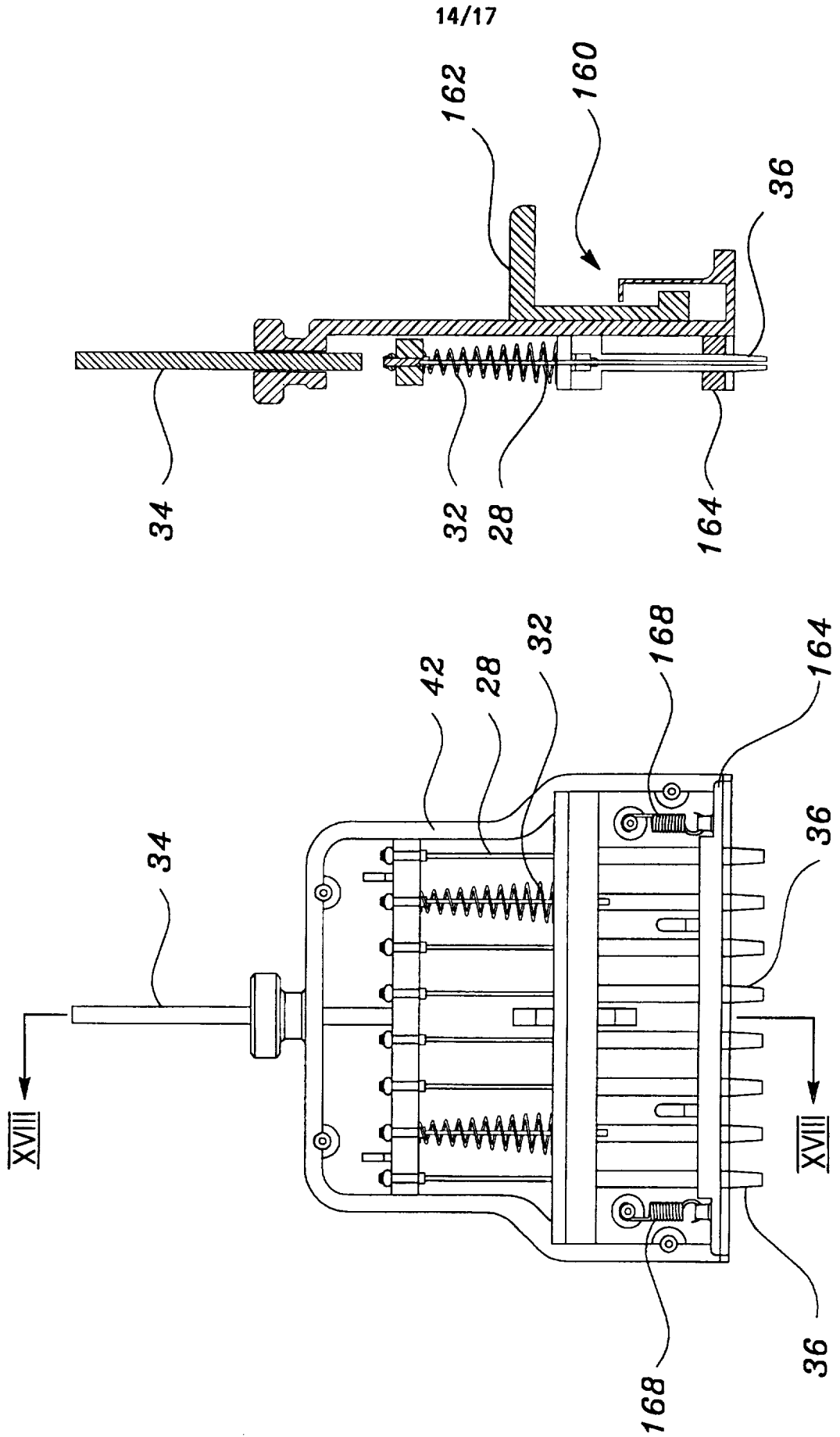

figure 18

figure 17

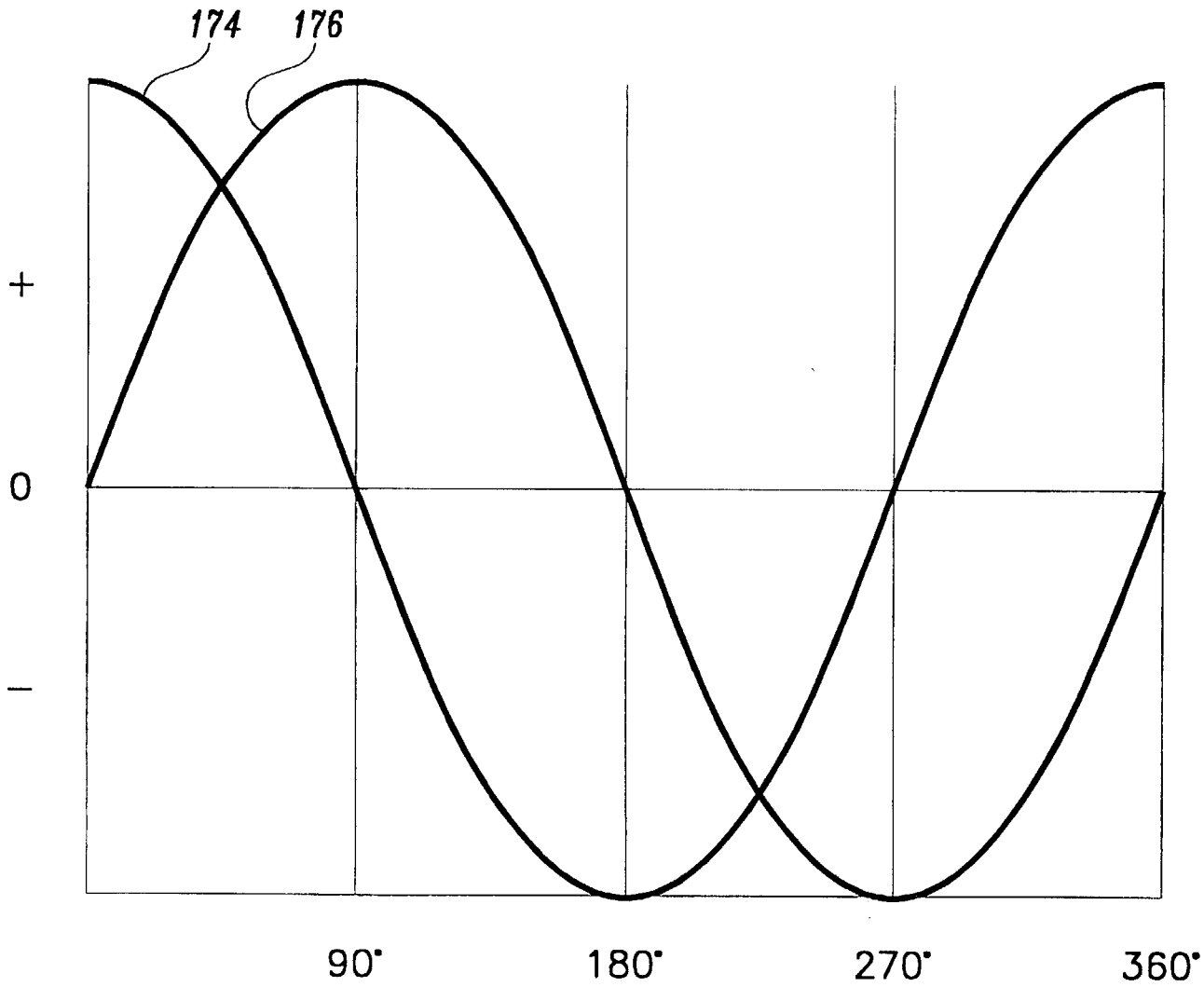

figure 19

16/17

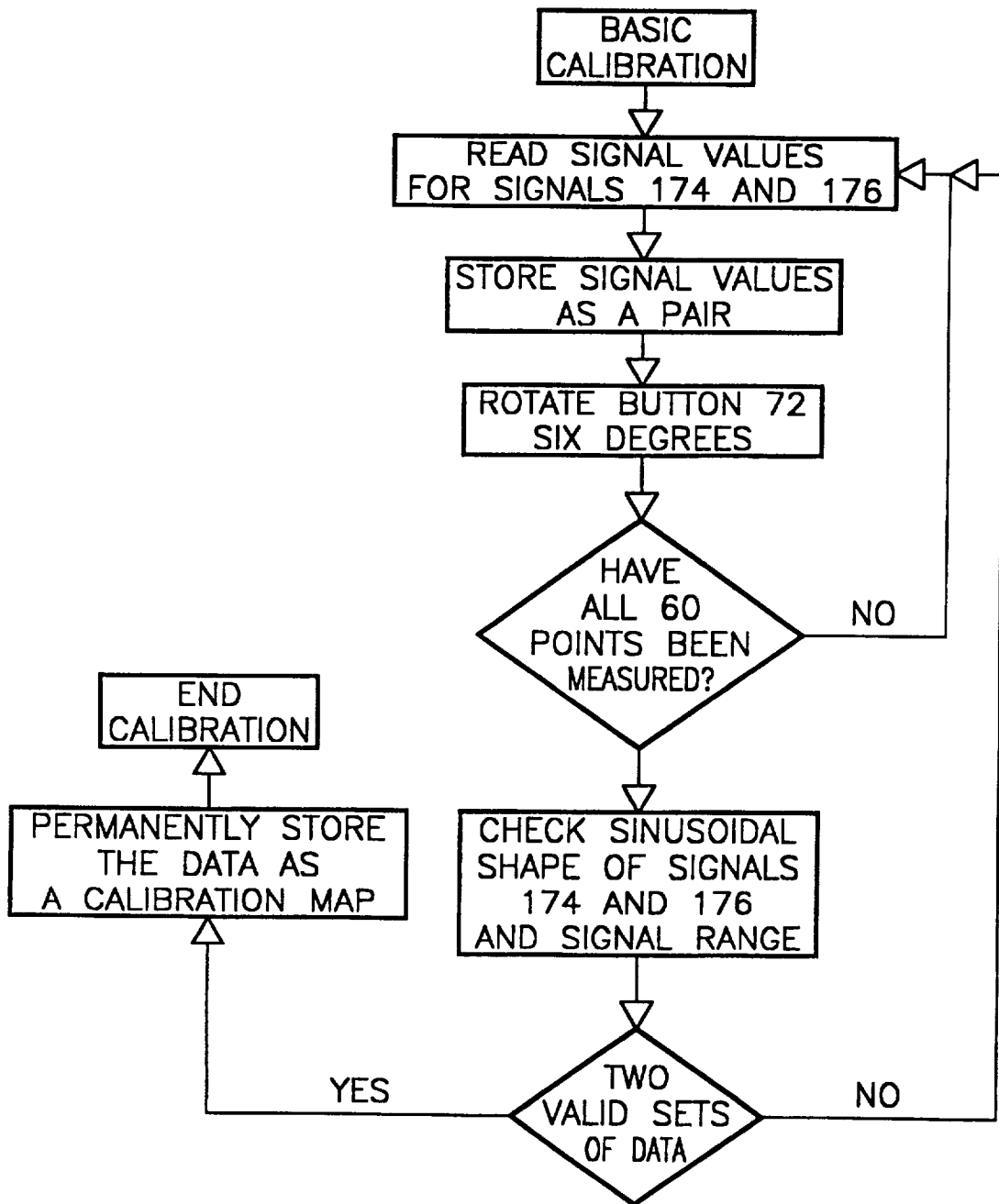

figure 20

17/17

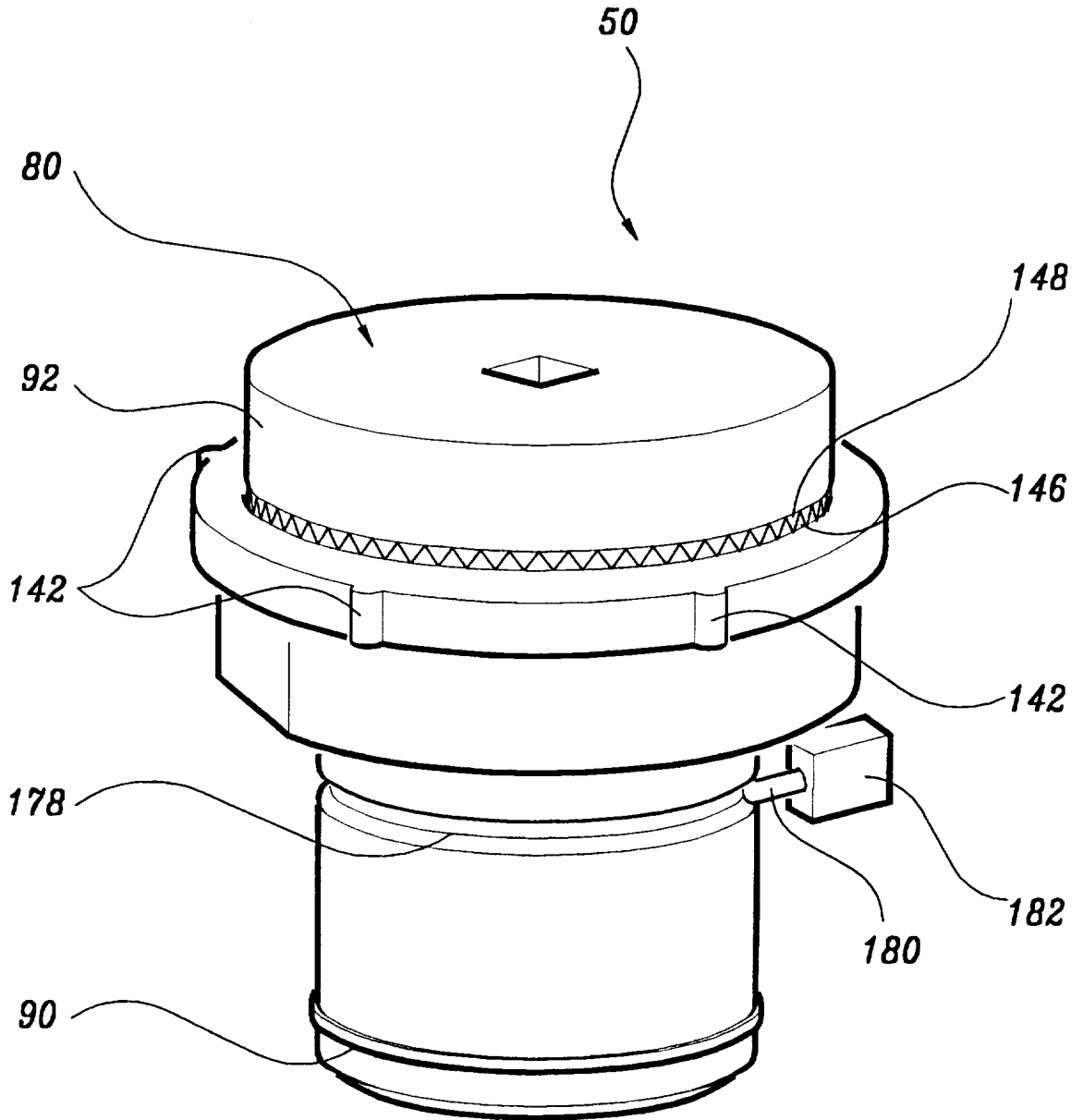

Figure 21

SUBSTITUTE SHEET (RULE 26)

INTERNATIONAL SEARCH REPORT

International application No.
PCT/US97/15866

A. CLASSIFICATION OF SUBJECT MATTER

IPC(6) :G01N 1/14
US CL :422/100

According to International Patent Classification (IPC) or to both national classification and IPC

B. FIELDS SEARCHED

Minimum documentation searched (classification system followed by classification symbols)

U.S. : 422/65, 100, 102, 104; 73/864.01, 864.13, 864.14, 864.18

Documentation searched other than minimum documentation to the extent that such documents are included in the fields searched

Electronic data base consulted during the international search (name of data base and, where practicable, search terms used)

APS

C. DOCUMENTS CONSIDERED TO BE RELEVANT

Category*	Citation of document, with indication, where appropriate, of the relevant passages	Relevant to claim No.
X ---- Y	US 4,905,526 A (MAGNUSSEN, Jr. et al) 06 March 1990, see entire document.	1-9,11,13-17,19-20 ----- 10,12,18
X ---- Y	US 5,108,703 A (PFOST et al) 28 April 1992, see entire document.	1-9,11,13-17,19-20 ----- 10,12,18
Y	US 5,525,302 A (ASTLE) 11 June 1996, see entire document.	1-20
Y	US 4,478,094 A (SALOMAA et al) 23 October 1984, see entire document.	1-20

Further documents are listed in the continuation of Box C. See patent family annex.

* Special categories of cited documents:	*T* later document published after the international filing date or priority date and not in conflict with the application but cited to understand the principle or theory underlying the invention
A document defining the general state of the art which is not considered to be of particular relevance	*X* document of particular relevance; the claimed invention cannot be considered novel or cannot be considered to involve an inventive step when the document is taken alone
E earlier document published on or after the international filing date	*Y* document of particular relevance; the claimed invention cannot be considered to involve an inventive step when the document is combined with one or more other such documents, such combination being obvious to a person skilled in the art
L document which may throw doubts on priority claim(s) or which is cited to establish the publication date of another citation or other special reason (as specified)	*A* document member of the same patent family
O document referring to an oral disclosure, use, exhibition or other means	
P document published prior to the international filing date but later than the priority date claimed	

Date of the actual completion of the international search

24 OCTOBER 1997

Date of mailing of the international search report

12 DEC 1997

Name and mailing address of the ISA/US
Commissioner of Patents and Trademarks
Box PCT
Washington, D.C. 20231

Facsimile No. (703) 305-3230

Authorized officer

HAROLD Y. PYON *Harold Y. Pyon*

Telephone No. (703) 308-0651

INTERNATIONAL SEARCH REPORT

International application No.
PCT/US97/15866

C (Continuation). DOCUMENTS CONSIDERED TO BE RELEVANT

Category*	Citation of document, with indication, where appropriate, of the relevant passages	Relevant to claim No.
Y	US 4,528,161 A (ECKERT) 09 July 1985, see entire document.	1-20
A	US 5,443,791 A (CATHCART et al) 22 August 1995, see entire document.	1-20