

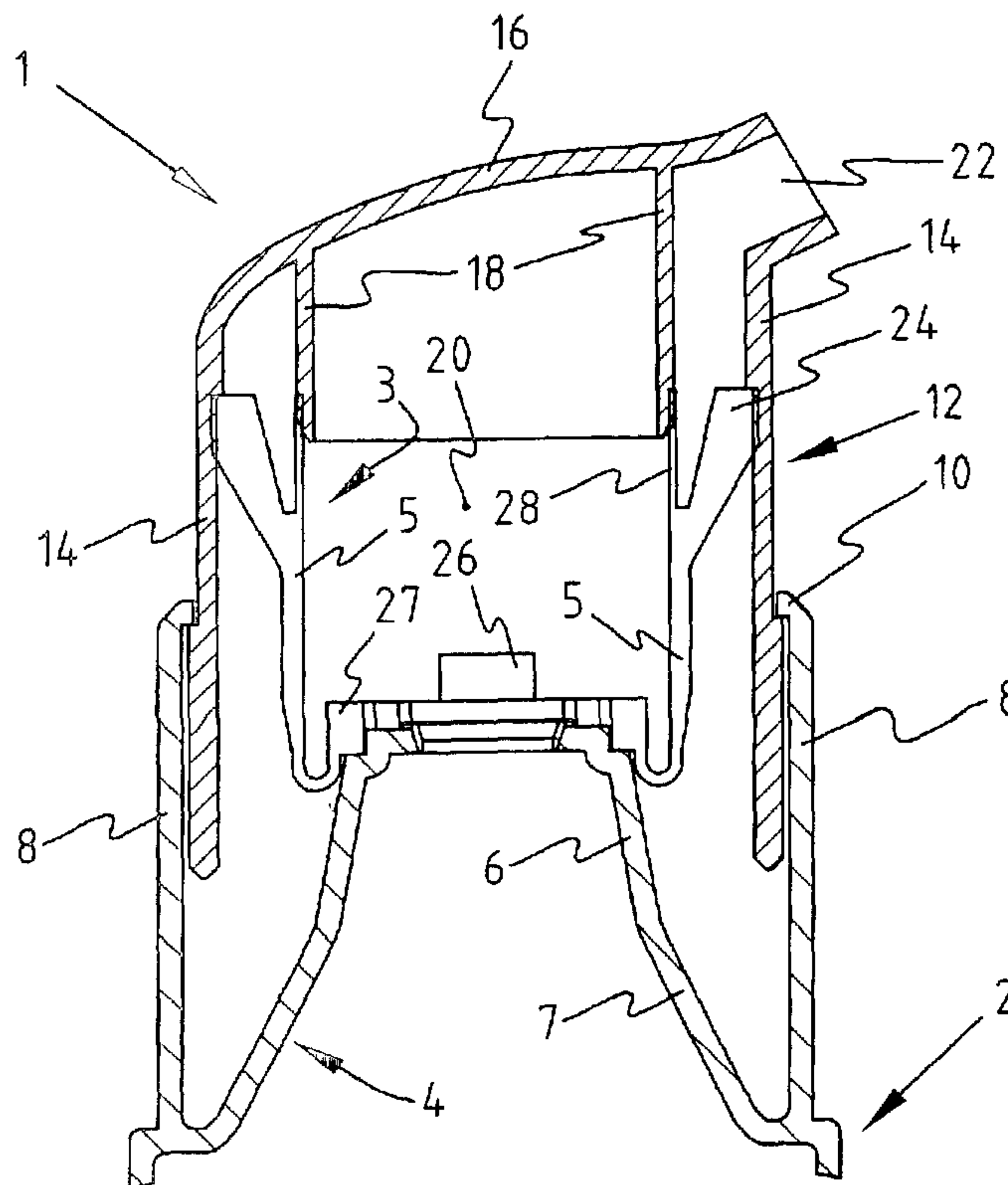

(86) Date de dépôt PCT/PCT Filing Date: 2003/07/03
 (87) Date publication PCT/PCT Publication Date: 2004/01/15
 (85) Entrée phase nationale/National Entry: 2004/12/24
 (86) N° demande PCT/PCT Application No.: NL 2003/000493
 (87) N° publication PCT/PCT Publication No.: 2004/004921
 (30) Priorités/Priorities: 2002/07/03 (1020983) NL;
 2003/06/13 (1023670) NL

(51) Cl.Int.⁷/Int.Cl.⁷ B05B 11/00
 (71) Demandeur/Applicant:
 KELTUB B.V., NL
 (72) Inventeurs/Inventors:
 NEERINCX, PETER EDUARD, NL;
 DE REGT, JEROEN DANIEL, NL
 (74) Agent: FETHERSTONHAUGH & CO.

(54) Titre : ENSEMBLE FORME D'UNE PARTIE DE SOUFFLET ET D'UNE PARTIE D'ACTIONNEMENT, POMPE ET
 PROCÉDE D'UTILISATION CORRESPONDANT
 (54) Title: SYSTEM OF BELLOWS AND CO-ACTING PART, PUMP AND METHOD FOR THE USE THEREOF



(57) **Abrégé/Abstract:**

The present invention provides an assembly of bellows part and a part against which unrolling takes place (the unrolling part), comprising a bellows part with a flexible wall of a predetermined shape and thickness variation which co-operates with an unrolling part with a stiff outer wall along which the flexible wall is movable, wherein the unrolling part has a predetermined diameter variation and/or the flexible wall has a predetermined thickness variation so as to cause a desired development of force.

(12) INTERNATIONAL APPLICATION PUBLISHED UNDER THE PATENT COOPERATION TREATY (PCT)

(19) World Intellectual Property
Organization
International Bureau



(43) International Publication Date
15 January 2004 (15.01.2004)

PCT

(10) International Publication Number
WO 2004/004921 A1

- (51) International Patent Classification⁷: **B05B 11/00**
- (74) Agent: **TABELING, Marcella, Maria, Josefa**; Arnold & Siedsma, Sweelinckplein 1, NL-2517 GK The Hague (NL).
- (21) International Application Number:
PCT/NL2003/000493
- (81) Designated States (*national*): AE, AG, AL, AM, AT, AU, AZ, BA, BB, BG, BR, BY, BZ, CA, CH, CN, CO, CR, CU, CZ, DE, DK, DM, DZ, EC, EE, ES, FI, GB, GD, GE, GH, GM, HR, HU, ID, IL, IN, IS, JP, KE, KG, KP, KR, KZ, LC, LK, LR, LS, LT, LU, LV, MA, MD, MG, MK, MN, MW, MX, MZ, NO, NZ, OM, PH, PL, PT, RO, RU, SD, SE, SG, SK, SL, TJ, TM, TN, TR, TT, TZ, UA, UG, US, UZ, VN, YU, ZA, ZM, ZW.
- (22) International Filing Date: 3 July 2003 (03.07.2003)
- (25) Filing Language: Dutch
- (26) Publication Language: English
- (30) Priority Data:
1020983 3 July 2002 (03.07.2002) NL
1023670 13 June 2003 (13.06.2003) NL
- (84) Designated States (*regional*): ARIPO patent (GH, GM, KE, LS, MW, MZ, SD, SL, SZ, TZ, UG, ZM, ZW), Eurasian patent (AM, AZ, BY, KG, KZ, MD, RU, TJ, TM), European patent (AT, BE, BG, CH, CY, CZ, DE, DK, EE, ES, FI, FR, GB, GR, HU, IE, IT, LU, MC, NL, PT, RO, SE, SI, SK, TR), OAPI patent (BF, BJ, CF, CG, CI, CM, GA, GN, GQ, GW, ML, MR, NE, SN, TD, TG).
- (71) Applicant (*for all designated States except US*): **KELTUB B.V.** [NL/NL]; Wolput 39, NL-5251 CC Vlijmen (NL).
- (72) Inventors; and
- (75) Inventors/Applicants (*for US only*): **NEERINX, Peter, Eduard** [NL/NL]; Zoom 39, NL-5061 RA Oisterwijk (NL). **REGT, Jercen, Daniël** [NL/NL]; Heischeuthof 4, NL-5345 VP Oss (NL).
- Published:**
— with international search report
- For two-letter codes and other abbreviations, refer to the "Guidance Notes on Codes and Abbreviations" appearing at the beginning of each regular issue of the PCT Gazette.*

(54) Title: SYSTEM OF BELLOWS AND CO-ACTING PART, PUMP AND METHOD FOR THE USE THEREOF

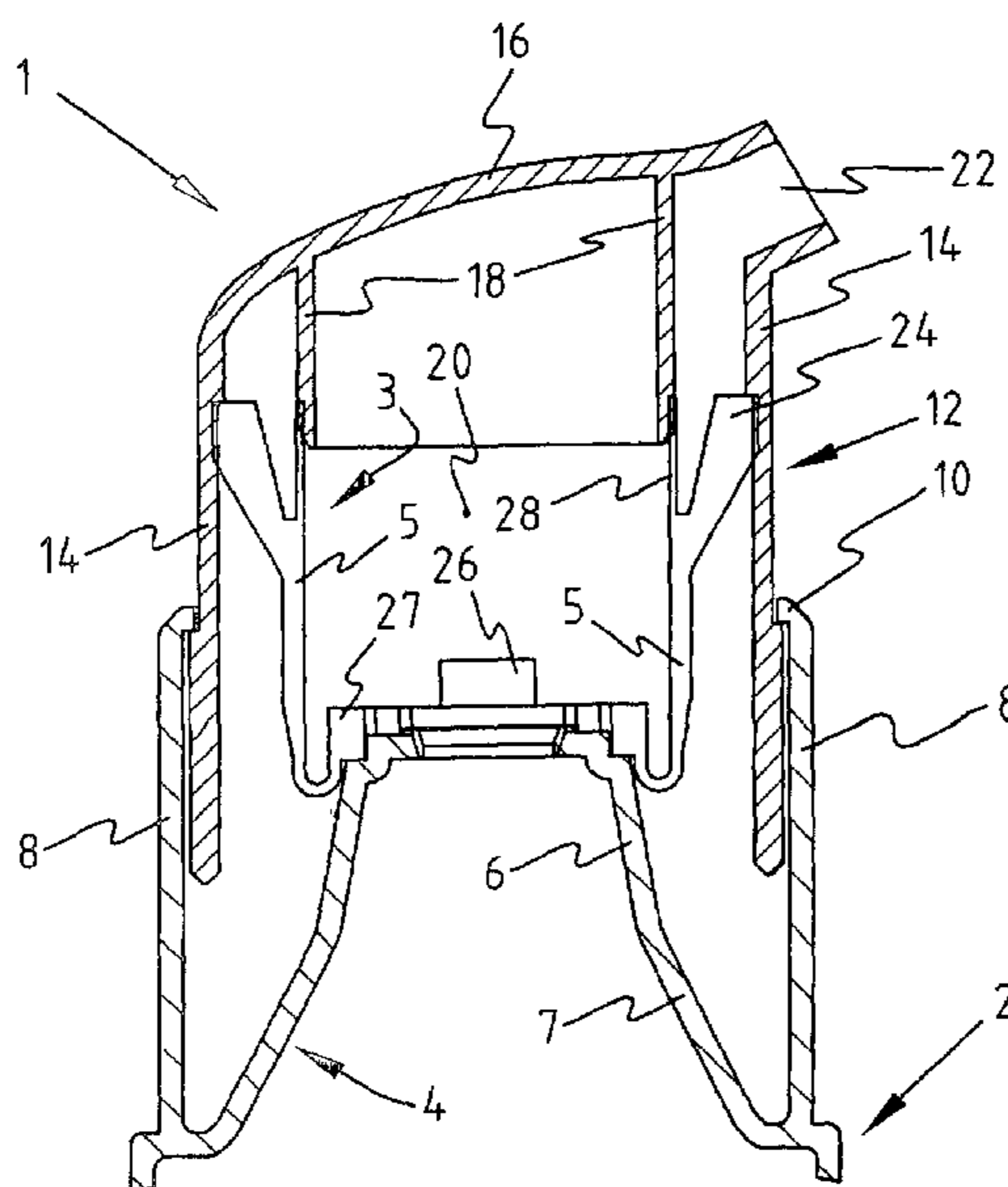

(57) Abstract: The present invention provides an assembly of bellows part and a part against which unrolling takes place (the unrolling part), comprising a bellows part with a flexible wall of a predetermined shape and thickness variation which co-operates with an unrolling part with a stiff outer wall along which the flexible wall is movable, wherein the unrolling part has a predetermined diameter variation and/or the flexible wall has a predetermined thickness variation so as to cause a desired development of force.

WO 2004/004921 A1

ASSEMBLY OF BELLOWS AND CO-ACTING PART,
PUMP AND METHOD FOR USE THEREOF

5

The present invention relates to an assembly of a bellows and a co-acting part, a pump comprising such an assembly and a method for use thereof.

10 A pump with a bellows is known from the American patent 4,347,953. This known pump is constructed from a minimum of four parts, i.e. a housing, a cap, a bellows and a part co-acting with the bellows. Such a bellows has a spring force which, after a determined compression has been passed, is lower than the initial value, whereby the
15 further compression is assisted. A flexible wall of the bellows moves in the free space during compression, whereby the development of force is uncontrolled. The application of this pump is limited to dispensing a predetermined amount of foam, liquid or gas.

20 The present invention has for its object to provide an improved bellows which is suitable for multiple applications.

The invention provides for this purpose an assembly of bellows part and co-acting part, comprising a bellows part
25 with a flexible wall of a predetermined shape and thickness which co-operates with the co-acting part, which comprises a stiff outer wall along which the flexible wall is movable.

30 Such an assembly provides a simpler and less expensive solution.

In a preferred embodiment the part against which unrolling takes place (the unrolling part) has a predetermined diameter variation and/or the flexible wall

has a predetermined thickness variation so as to cause a desired development of force.

Owing to the co-operation of the flexible wall with the unrolling part it is found possible to determine the development of force as desired so that, depending on the application, the spring characteristic can be predetermined.

In a preferred embodiment the flexible wall is partially turned back and wherein a turned-back edge is arranged on an outer end thereof for absorbing a pressure force. The turned-back edge provides a stable point of engagement for transmitting pressure forces in controlled manner from the unrolling part onto the bellows part and vice versa.

In a preferred embodiment the development of force is constant, increasing, decreasing or a combination thereof. Practically any desired development of force can thus be obtained.

In a preferred embodiment the development of force comprises one or more peaks. An oscillating development of force is thus achieved, for instance for an improved dispensing.

In a preferred embodiment the outer end of the unrolling part is conical. This is found to produce the desired control of the development of force.

In a preferred embodiment the outer end of the unrolling part comprises a thickened portion for the purpose of causing a peak in the development of force. The peak in the development of force indicates that a determined point has been reached and thus acts as dispensing indication, wherein both the end quantity, for instance 10 ml, and the quantity at the force peak, for instance 5 ml, apply as reference.

In a further preferred embodiment the outer end comprises a bend.

In a further preferred embodiment the outer end comprises a part of concave cross-section for the purpose
5 of causing an increasing spring force.

In a further preferred embodiment the outer end comprises a part of convex cross-section for the purpose of causing a decreasing spring force.

Further advantages and features are discussed with
10 reference to the annexed figures, in which:

fig. 1a and 1b show a cross-section of a pump with an assembly according to the invention in a first preferred embodiment, and in a first and a second position of use;

fig. 1c shows the development of force of the assembly
15 of fig. 1a;

fig. 2a and 2b show a cross-section of a pump with an assembly according to the invention in a second preferred embodiment, and in a first and a second position of use;

fig. 2c shows the development of force of the assembly
20 of fig. 2a;

fig. 3a and 3b show a cross-section of a pump with an assembly according to the invention in a third preferred embodiment, and in a first and a second position of use;

fig. 3c shows the development of force of the assembly
25 of fig. 3a;

fig. 4a and 4b show a cross-section of a pump with an assembly according to the invention in a fourth preferred embodiment, and in a first and a second position of use;

fig. 4c shows the development of force of the assembly
30 of fig. 4a;

fig. 5 shows a cross-section in perspective of a pump provided with an assembly according to the present invention in a fifth preferred embodiment;

fig. 6 shows a partly cut-away perspective view of a bellows according to the present invention in a sixth preferred embodiment;

fig. 7 shows a perspective view of a bellows according to the present invention in a seventh preferred embodiment;

fig. 8a-8c are top views of the bellows of fig. 6 provided with a suction valve in three different embodiments; and

fig. 9 is a perspective view of a suction valve in an eighth preferred embodiment.

A pump 1, for instance suitable for liquids, pasty material, foam or gases present in a container 2, comprises an assembly of a bellows or bellows part 3 and a co-acting part or unrolling part 4 comprising an outer wall over which a flexible wall 5 of the bellows can unroll (fig. 1a and 1b).

In the shown first preferred embodiment the unrolling part 4, which is for instance point-symmetrical, comprises a first conical part 6 and a second conical part 7 which is connected thereto and has a different angle of inclination and is manufactured integrally with container 2, which further comprises an upright wall 8 with a stop 10 at the top. The wall 8 as shown is cylindrical, although all shapes such as oval or square are possible. The upper part 12 comprises a cylindrical side wall 14 with a thickened portion which rest against stop 10 in a starting position (fig. 1a). The upper part further comprises an upper wall 16 on which the cylindrical wall 18 is arranged on the inside so as to form a chamber 20, and a spout 22 which serves as outflow opening.

Bellows 3 is point-symmetrical and comprises the flexible cylindrical wall 5 with a thickness variation which is such that a desired spring characteristic is obtained, a

thickened base 24 which supports against a recess in wall 14 (or for instance against a rib on wall 14), and suction valve 26 which is connected to the turned-back edge 27 and serves to draw in the material from container 2. A
5 relatively thin cylindrical pressure valve 28 rests against the outside of wall 18. The turned-back edge 27 supports on the top of unrolling part 4 in order to absorb pressure force.

A part of flexible wall 5 is turned back for a
10 resilient action. Bellows 3 is manufactured for this purpose from a sufficiently elastically deformable material, such as Skypel[®], a thermoplastic polyester, or an elastomer such as silicone rubber. The material of the bellows is preferably a thermoplastic polymer or an
15 elastomer with a low damping so that the material returns more quickly to its original position.

During use of pump 1 a user exerts force on the upper wall 16, wherein the flexible wall 5 unrolls against unrolling part 4 until a second extreme position is reached
20 (fig. 1b). Chamber 20 becomes smaller so that an overpressure is created and valve 28 is pressed outward and the content of chamber 20 flows out of the pump via spout 22.

The development of force can be predetermined by the
25 combination of the wall thickness variation of flexible wall 5 and the path of the outer surface of unrolling part 4 against which the wall 5 unrolls. During the unrolling an increasingly large part of the bellows comes into contact with the unrolling part. The force F (y-axis) as a function
30 of the compression S (x-axis) of the pump of fig. 1a is shown in fig. 1c, and the development is roughly level. That is, a user must exert a roughly constant force when pressing upper part 12 downward relative to part 2.

The development of force shown in fig. 1c can be predetermined as desired and depending on the application, so that a constant, increasing or decreasing development, as well as a combination thereof, are among the possibilities. An initially relatively great force followed by a further smaller force, wherein a user has the feeling of tension being released, is also possible. One or more indication peaks or valleys are also possible, wherein the force at a determined compression has a manually discernible differing value, so that a user knows that this particular point has been reached. An indication peak can thus lie for instance at 5 ml, while the end value is 10 ml, whereby dispensing is simpler.

An increasing development of force is for instance obtained by making a first part 34 of the unrolling part concave in cross-section (fig. 2a, 2b), wherein the same bellows as shown in fig. 1a, 1b is used and the pump further comprises the same components. The curvature of part 34 increases towards the bottom, so that the force required to press upper part 12 downward also increases (fig. 2c).

A decreasing force with compression is for instance obtained by making an upper part 38 of the unrolling part convex in cross-section, wherein the angle of inclination is varied for a changing force (fig. 3a-3c).

In a fourth preferred embodiment the unrolling part comprises a first conical part 50 and a second conical part 52 with a different angle of inclination. Arranged around the outside of first part 50 is a rib 54 which causes a peak in the force when the flexible wall 5 unrolls thereover (fig. 4a-4c). A plurality of ribs can of course be arranged to cause multiple peaks. In practice the force peaks provide an increase in force of about 10%.

A fifth preferred embodiment (fig. 5) provides a pump 100 which comprises a container 102 for mounting on a bottle with for instance cleaning liquid, on which a spray nozzle 104 is arranged. The spray nozzle comprises a housing 106 in which is arranged an assembly according to the invention comprising a bellows 108 with flexible wall 110 which co-operates with an unrolling part 112. The assembly can be operated by a pistol mechanism comprising a lever 114 which is coupled via connection 118 to the unrolling part. Parts 116, 120 and 122 serve for venting. The base 124 of the bellows supports against housing 106 on which edge 126 is integrally arranged. In the housing is further arranged an opening 127 and a spray orifice 128 for egress therethrough of the content of container 102.

During use force is exerted on lever 114, whereby unrolling part 112 moves to the right in fig. 5, wherein the wall 110 unrolls over the unrolling part. When the unrolling part moves to the right pressure is built up inside bellows 108, wherein at a predetermined threshold value the edge 126 no longer seals, so that the content of the bellows is pressed out of the pump via opening 127 and spray orifice 128. Owing to the higher pressure built up in this embodiment and the relatively small diameter of spray orifice 128, the content is atomized as it leaves the spray orifice.

In the shown embodiment (fig. 5) the unrolling part is movable in the direction of the bellows. It is likewise possible to arrange the bellows such that it is movable in the direction of the unrolling part, i.e. in figure 5 the bellows will move to the left when lever 114 is operated.

In practical embodiments the stroke S varies between 10 mm and 25 mm. For a pump to be operated manually as shown in fig. 1a, the maximum force F is about 20 N to 30

N, with a minimum value of 5 N for specific applications. Higher pressures are needed to atomize a liquid. The maximum force on the bellows is then about 250 N to 300 N. Manual operation then takes place via a lever mechanism or
5 a pistol mechanism (fig. 5). The angle of inclination of the unrolling part varies within a range of 0° to 135° so as to obtain the desired development of force. For a low force an angle of inclination of 10° is a practical value.

The bellows of figures 1-4 comprises the thickened
10 conical basis 24 (fig. 6) which encloses an annular valve 28. An upper side of the base is connected to the cylindrical flexible wall 5. Arranged on the other end thereof is a turned-back edge which is connected to thickened edge 27. The annular, flat upper side of edge 27
15 serves as support surface for the top side of unrolling part 4. Edge 27 encloses the disc-shaped suction valve 26 which is arranged on edge 27 with three flexible arms 60. Valve 26 comprises a pin-like protrusion 62, for instance for guiding the valve 26.

20 A practical embodiment of bellows 3 (fig. 6) has for instance a height of 1 to 5 cm, a cross-section of 1 to 4 cm, a wall thickness of wall 5 of 0.1 to 5 mm, and preferably a wall thickness between 0.2 and 2 mm. Valve 28 has a wall thickness of 0.1 to 0.5 mm, valve 60 has a
25 cross-section of 2 to 10 mm, and base 24 has a thickness in the order of 1 to 15 mm.

The force with which unrolling takes place can also be determined by adapting the form and the wall thickness of the bellows. In a further preferred embodiment a bellows
30 according to the invention comprises a base 64 on which a flexible wall 66 is arranged, which wall has in cross-section a roughly parabolic progression (fig. 7), whereby a decreasing force is obtained. For an increasing or

decreasing force wall variations are likewise possible in accordance with a function of higher or lower order. Wall 66 is also higher than wall 5, so that it can be unrolled further. The suction valve and the pressure valve are not
5 shown.

Suction valve 36 is arranged on edge 27 with for instance three straight arms 60 (fig. 8a). The whole bellows is of the same material so that the arms are slightly flexible and valve 26 can move. For an improved
10 spring action the valve is arranged on edge 27 via Z-shaped arms 70 (fig. 8b) or arms 72 (fig. 8c). By making the connecting line of the Z longer or shorter, a smaller or greater spring force is obtained and valve 26 can open to a greater or lesser extent, which is important for pasty
15 fluid such as toothpaste.

For a flexible suspension the suction valve 26 can likewise be provided with arms 74 which are C-shaped in side view (fig. 9) and which otherwise have the same action and function as the Z-shaped arms as described above.

20 The present invention is not limited to the above described preferred embodiments thereof, in which many modifications can be envisaged; the protection sought is defined on the basis of the appended claims.

EPO - DG 1

International application PCT/NL03/00493
enclosure to letter dated 23-08-2004

1

23. 08. 2004

NEW CLAIMS

(78)

1. Assembly of bellows part (3) and co-acting part (4), comprising a bellows part (3) with a flexible wall (5) of a predetermined shape and thickness which co-operates with the co-acting part (4), which comprises a stiff outer wall along which the flexible wall (5) is movable, characterized in that an outer end (6,7; 34; 38; 50, 52) of the co-acting part (4) is substantially conical.

10

2. Assembly as claimed in claim 1, wherein the co-acting part (4) is a part against which unrolling takes place (unrolling part (4)) and wherein the stiff outer wall has a predetermined diameter variation and/or the flexible wall (5) has a predetermined thickness variation so as to cause a desired development of force.

15

3. Assembly as claimed in claim 1 or 2, wherein the flexible wall (5) is partially turned back and wherein a turned-back edge (27) is arranged on an outer end thereof for the purpose of absorbing a pressure force.

20

4. Assembly as claimed in claim 2 or 3, wherein the development of force is constant, increasing, decreasing or a combination thereof.

25

5. Assembly as claimed in claim 2, 3 or 4, wherein the development of force comprises one or more peaks.

30

6. Assembly as claimed in any of the claims 1-5, wherein the outer wall of the unrolling part (4) comprises a thickened portion (54) for the purpose of causing a peak in the development of force.

7. Assembly as claimed in any of the claims 1-6, wherein the outer wall of the unrolling part (4) comprises a bend (6,7).

5

8. Assembly as claimed in claims 1-7, wherein the outer wall of the unrolling part (4) comprises a part of concave cross-section (34) for the purpose of causing an increasing spring force.

10

9. Assembly as claimed in any of the claims 1-8, wherein the outer end of the unrolling part (4) comprises a part of convex cross-section (38) for the purpose of causing a decreasing spring force.

15

10. Assembly as claimed in any of the claims 1-9, wherein the thickness variation of the flexible wall (5) of the bellows part (3) at least partially determines the development of force.

20

11. Assembly as claimed in any of the foregoing claims, wherein the bellows part (3) is of a thermoplastic polymer or an elastomer.

25

12. Assembly as claimed in any of the foregoing claims, wherein the flexible wall (5) of the bellows part (3) is substantially cylindrical.

30

13. Assembly as claimed in any of the foregoing claims, wherein the wall of the bellows part (3) is of substantially convex cross-section.

14. Assembly as claimed in any of the foregoing claims, wherein the bellows part (3) comprises an integrated pressure valve (28) and/or an integrated suction valve (26).

5 15. Assembly as claimed in claim 14, wherein the suction valve (26) comprises a number of, for instance three, legs (60; 70; 72; 74) which are connected to the flexible wall (5).

10 16. Assembly as claimed in claim 15, wherein the legs (70; 72) are Z-shaped in top view for an improved spring action.

15 17. Assembly as claimed in claims 14-16, wherein the suction valve (26) comprises a guide protrusion (62) for guiding the suction valve.

18. Assembly as claimed in claims 14-17, wherein the pressure valve (28) is a cylindrical flexible wall.

20

19. Pump (1; 100) comprising an assembly as claimed in any of the claims 1-18.

25 20. Pump (100) as claimed in claim 19, comprising a pistol mechanism in which the assembly is incorporated.

21. Method for using an assembly as claimed in any of the claims 1-18 and/or a pump (1; 100) as claimed in claims 19-20.

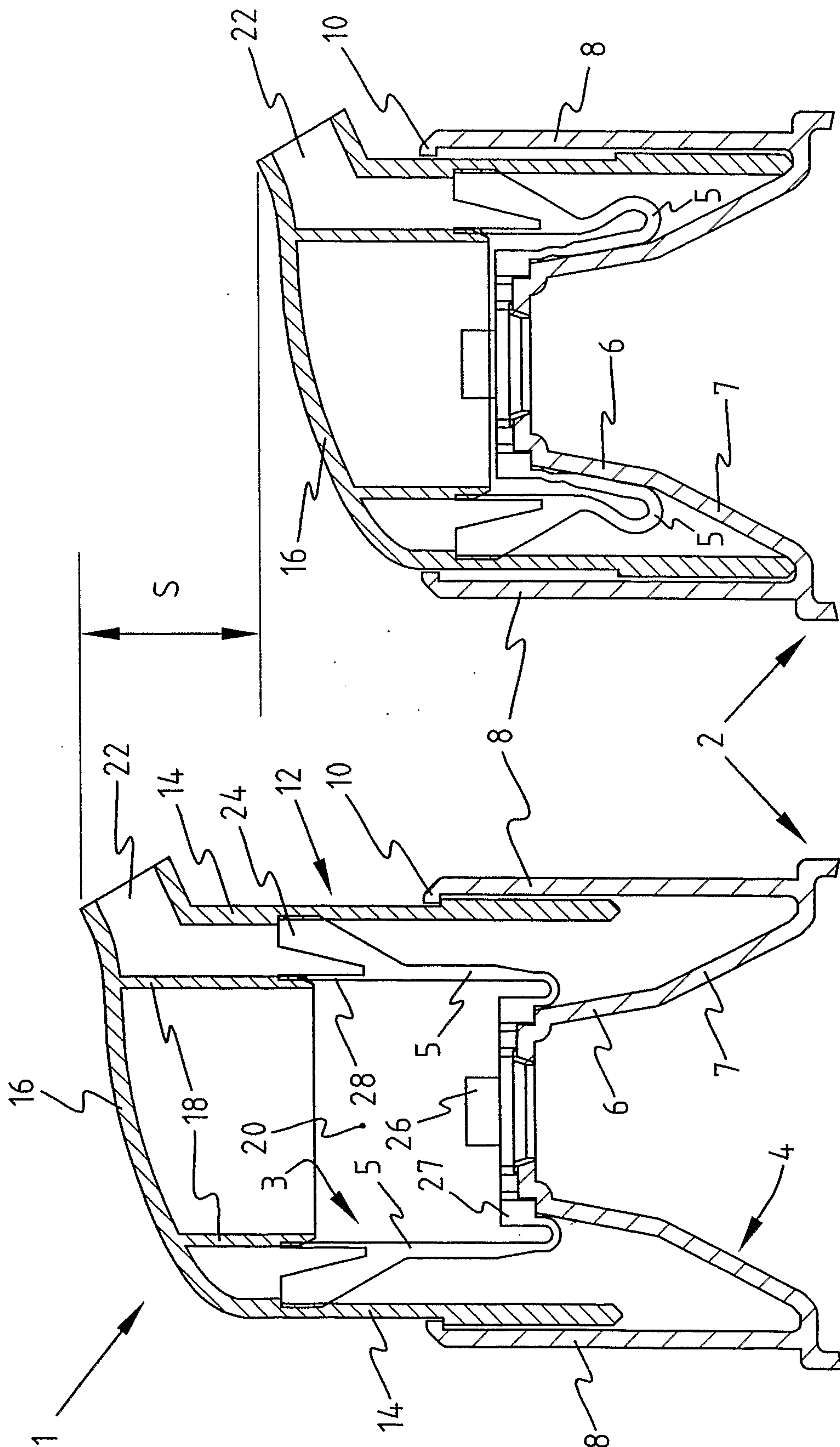
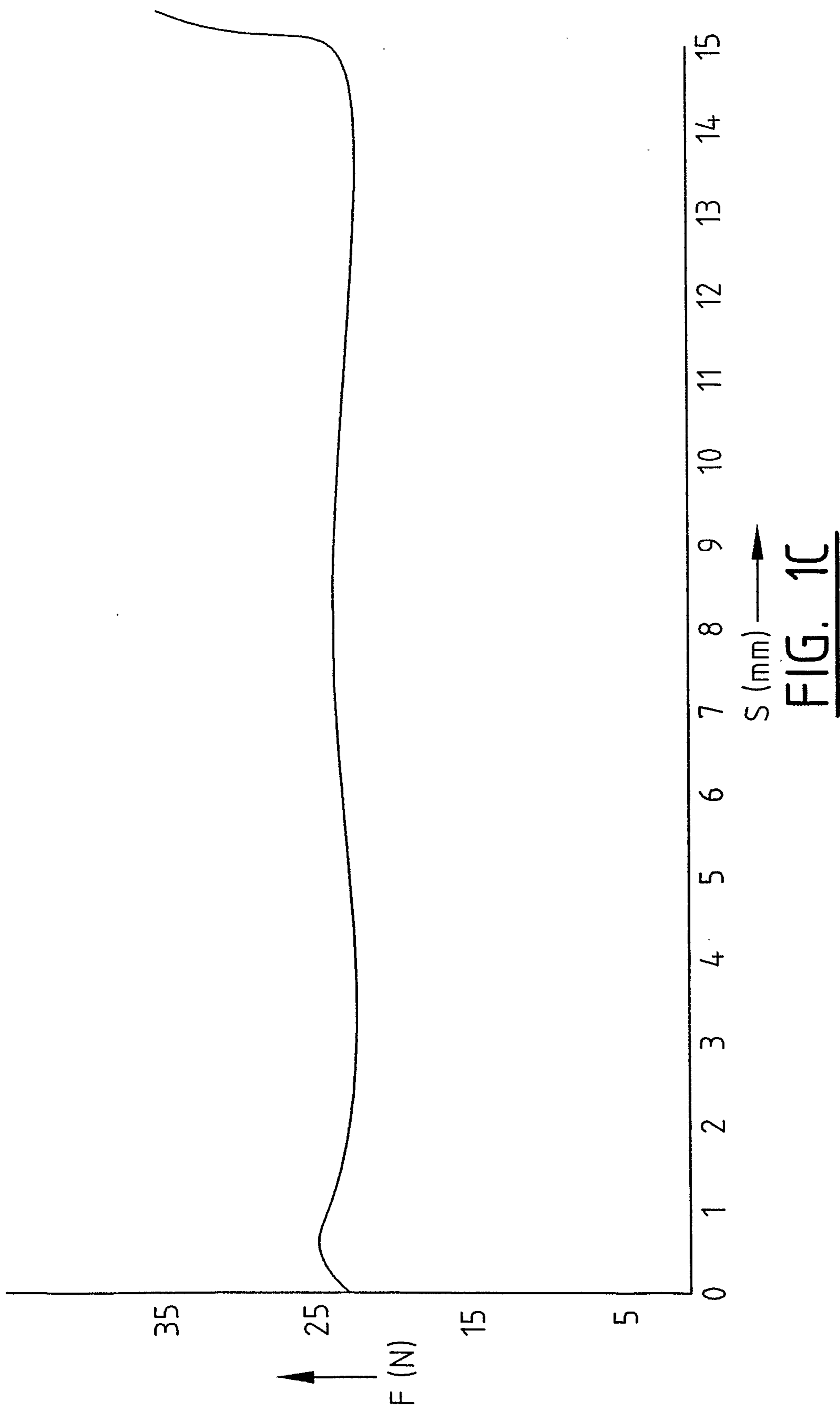

FIG. 1B

FIG. 1A

2/13



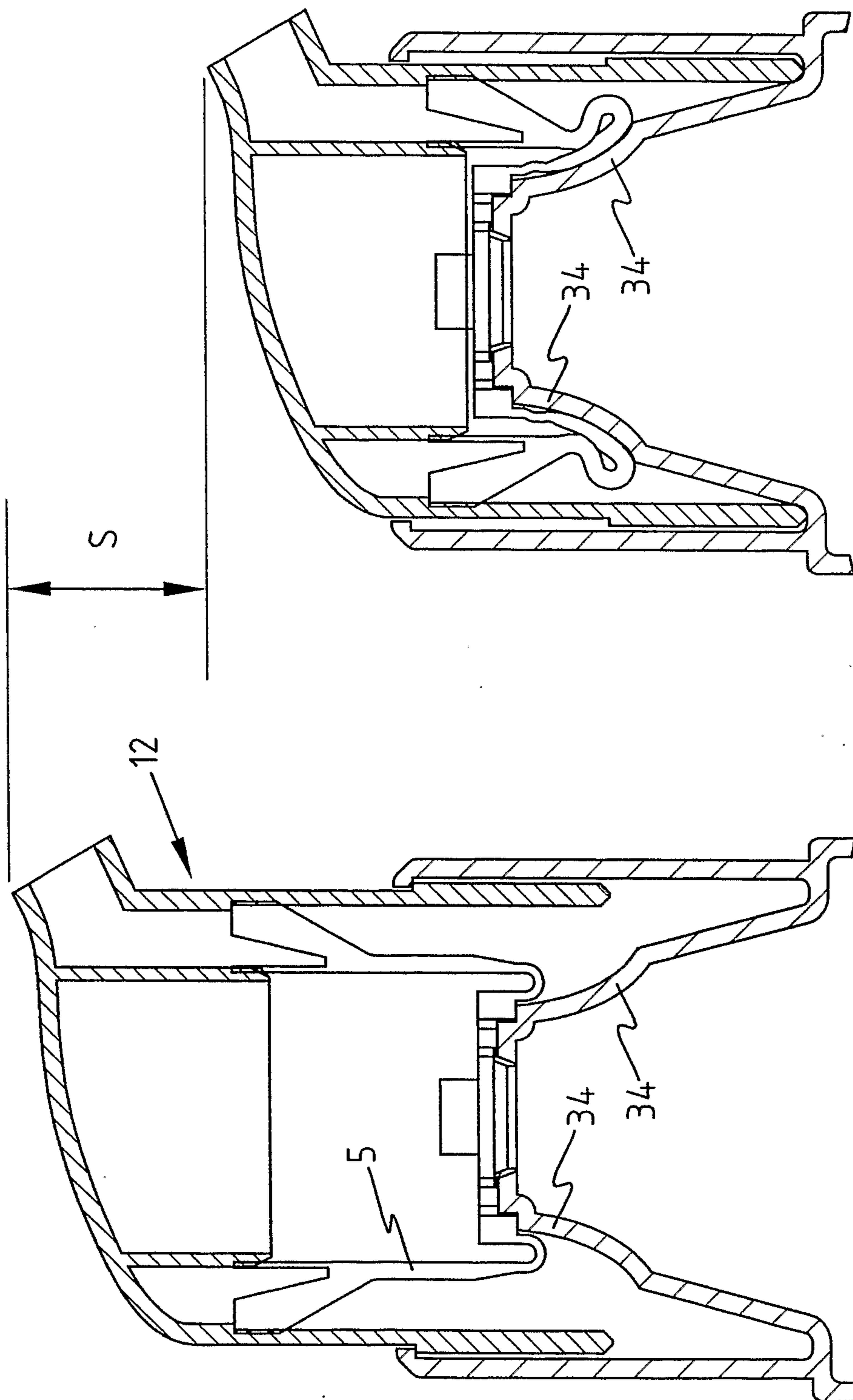
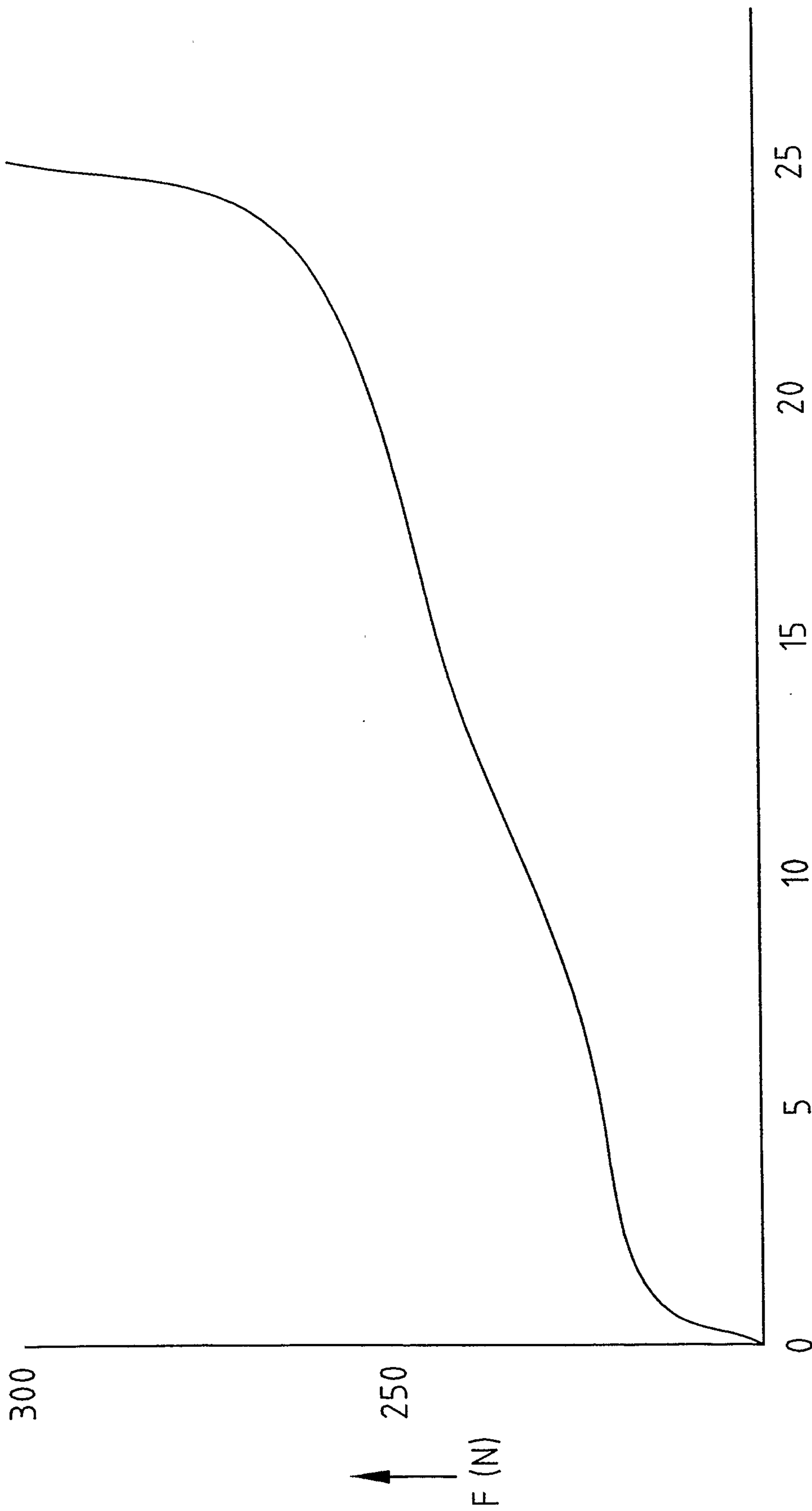

FIG. 2B

FIG. 2A

4/13



S (mm) →

FIG. 2C

5/13

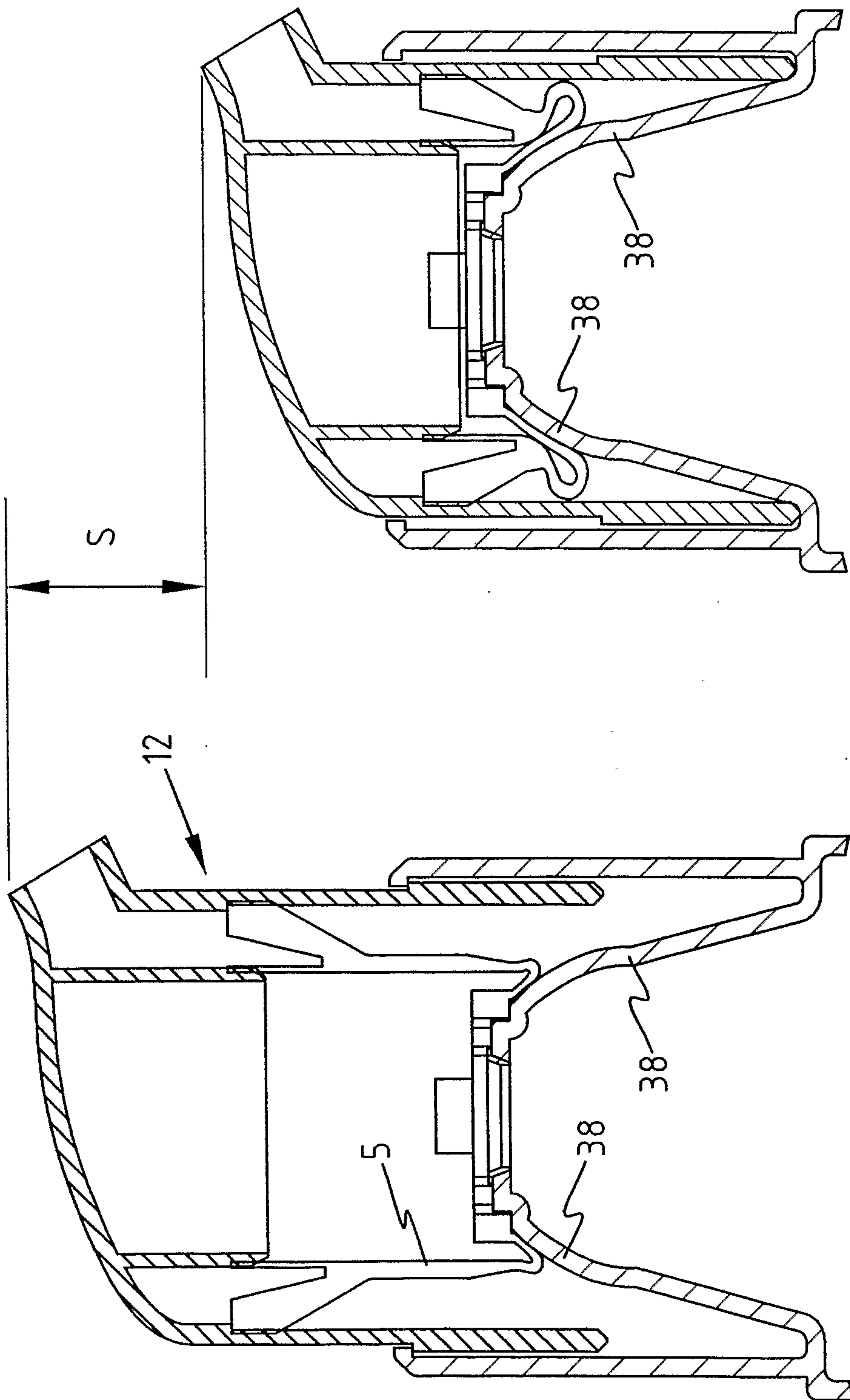
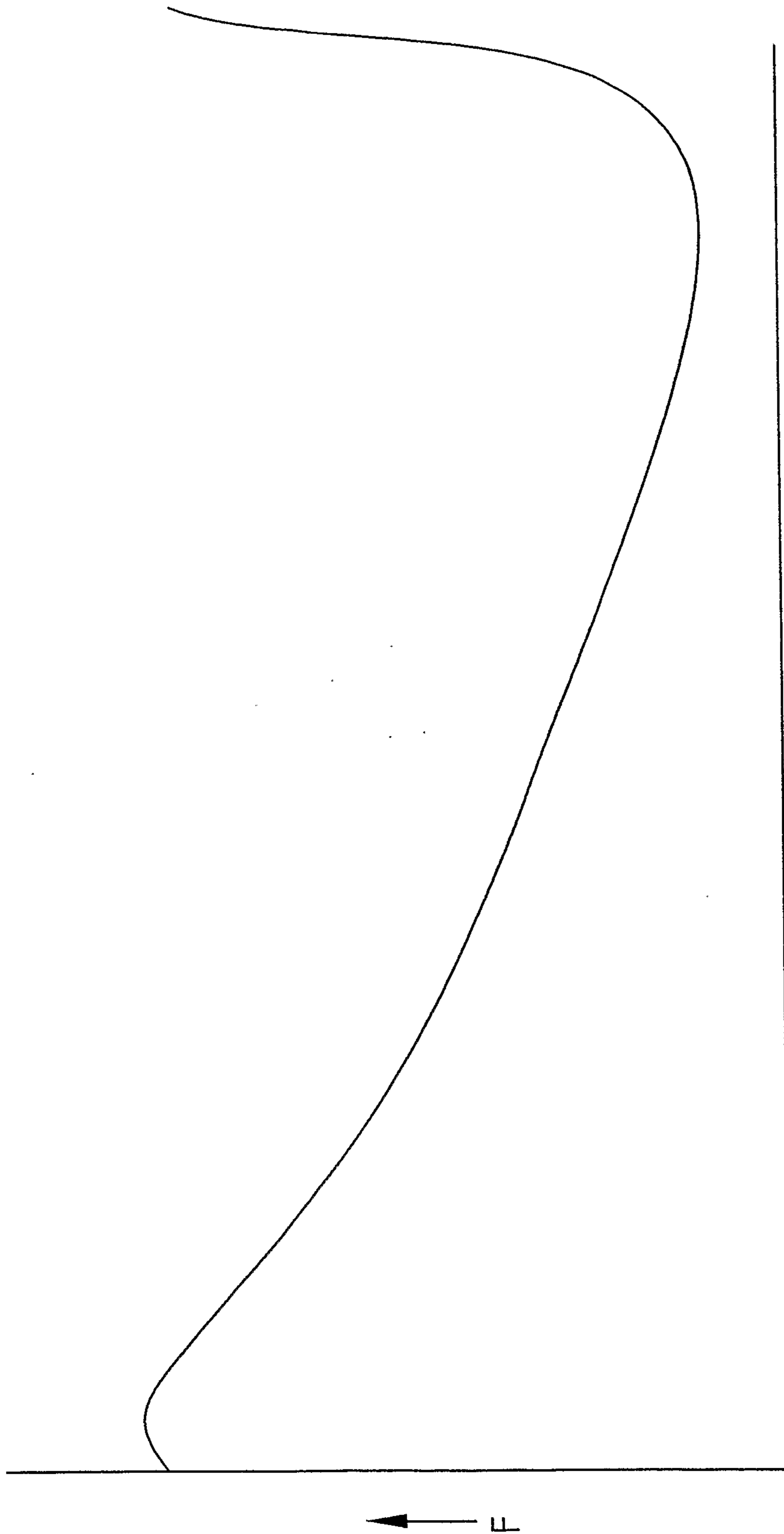

FIG. 3B

FIG. 3A

6/13



S

FIG. 3C

7/13

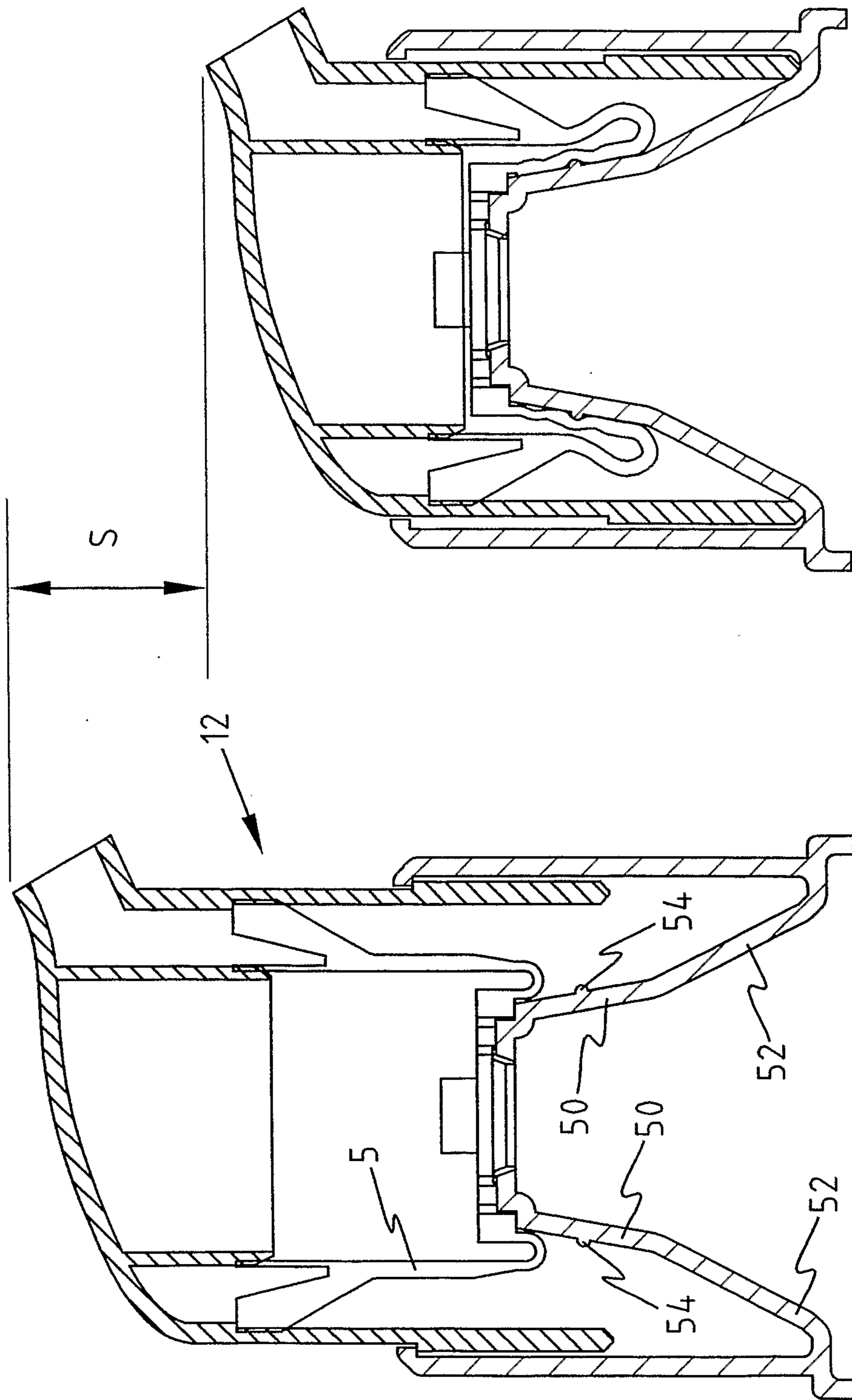

FIG. 4B

FIG. 4A

8/13

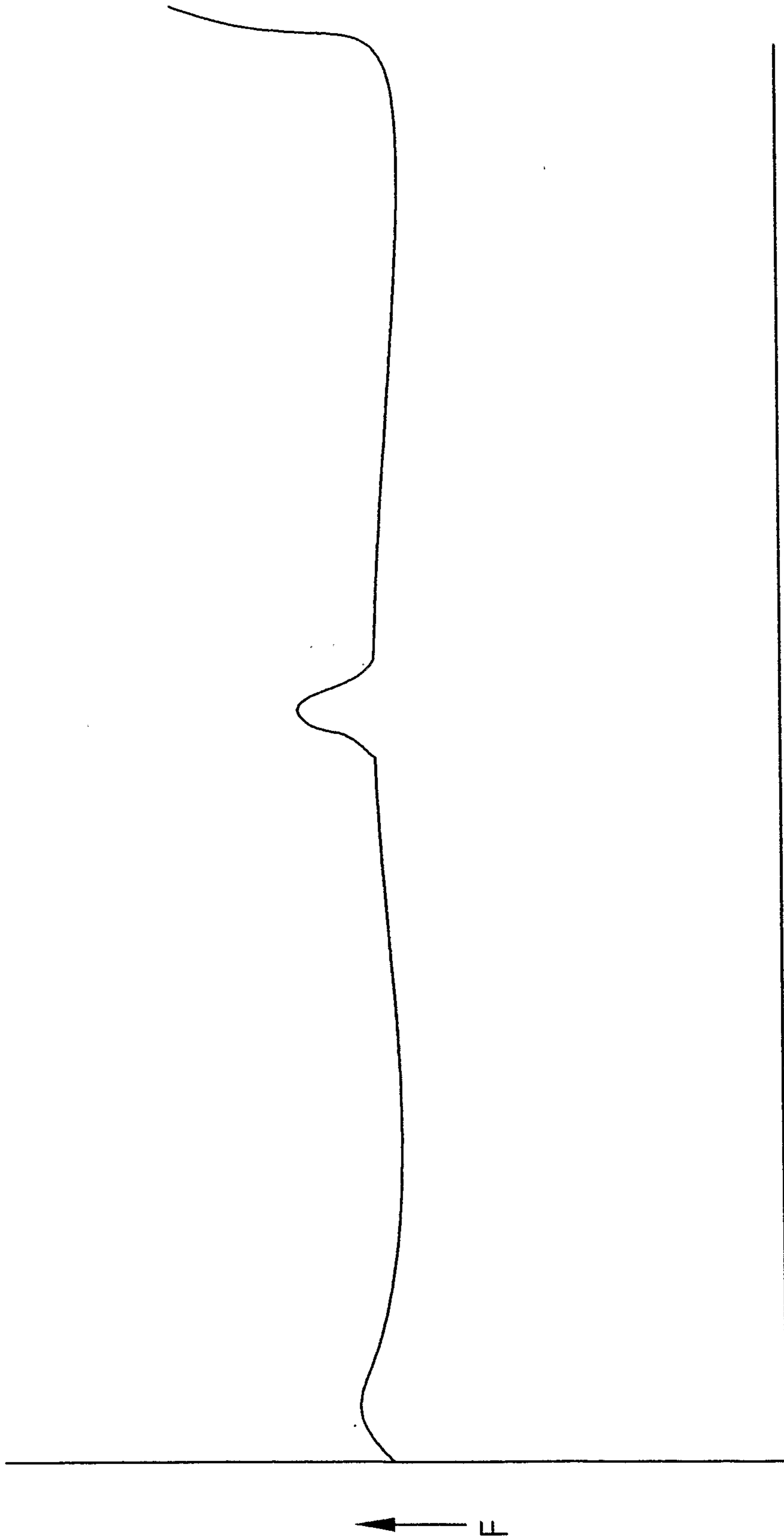

FIG. 4C

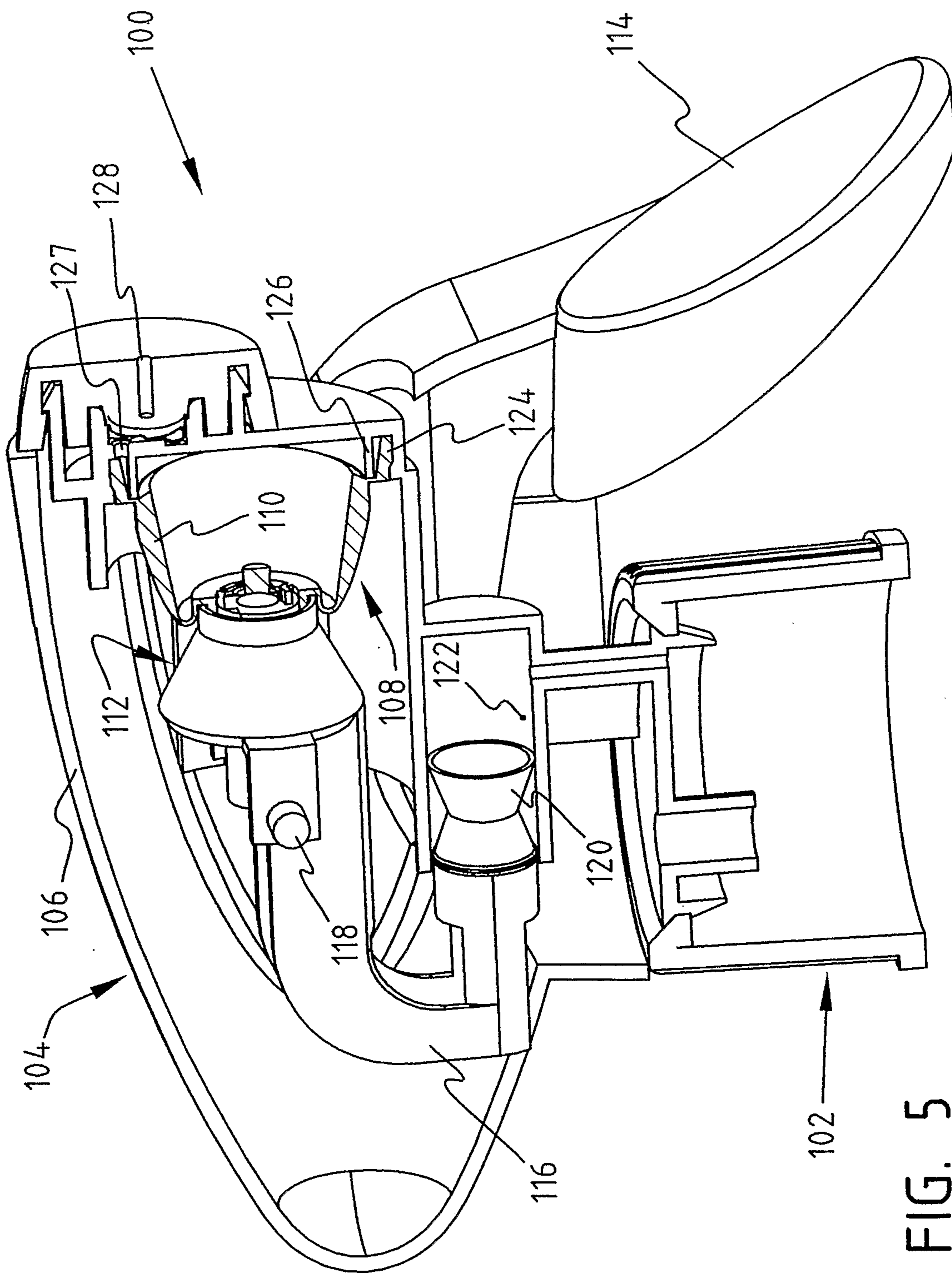

FIG. 5

10/13

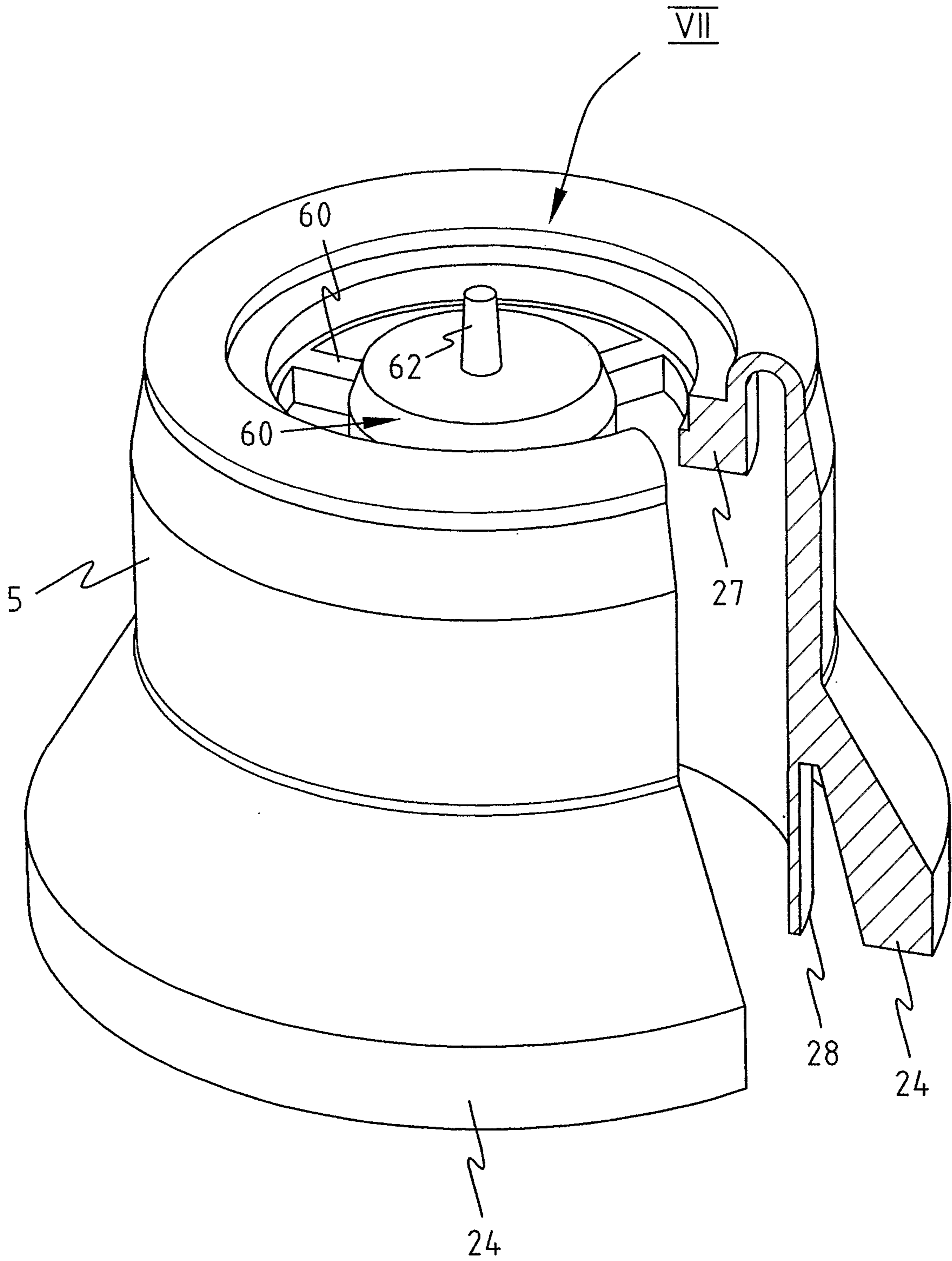

FIG. 6

11/13

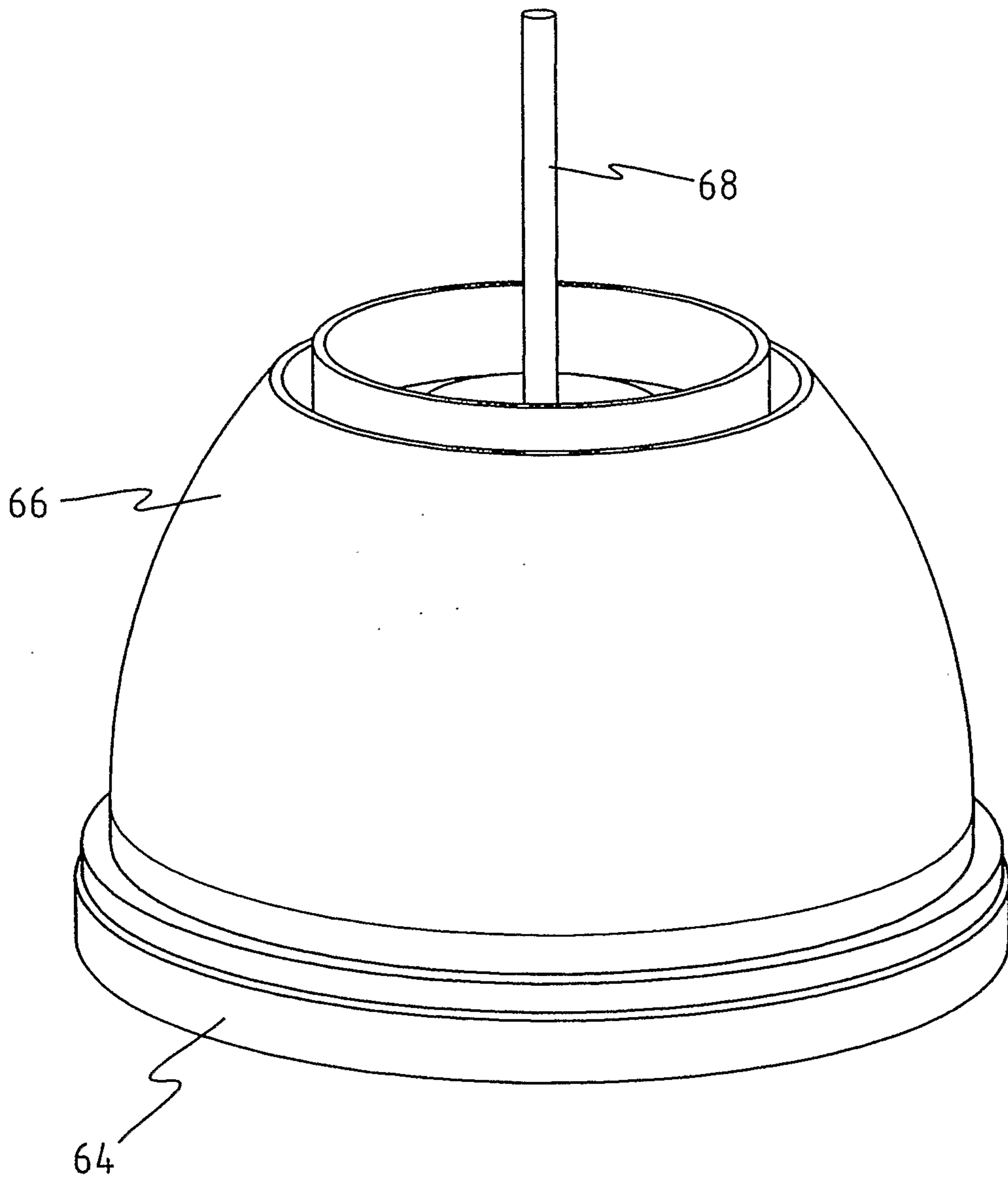

FIG. 7

12/13

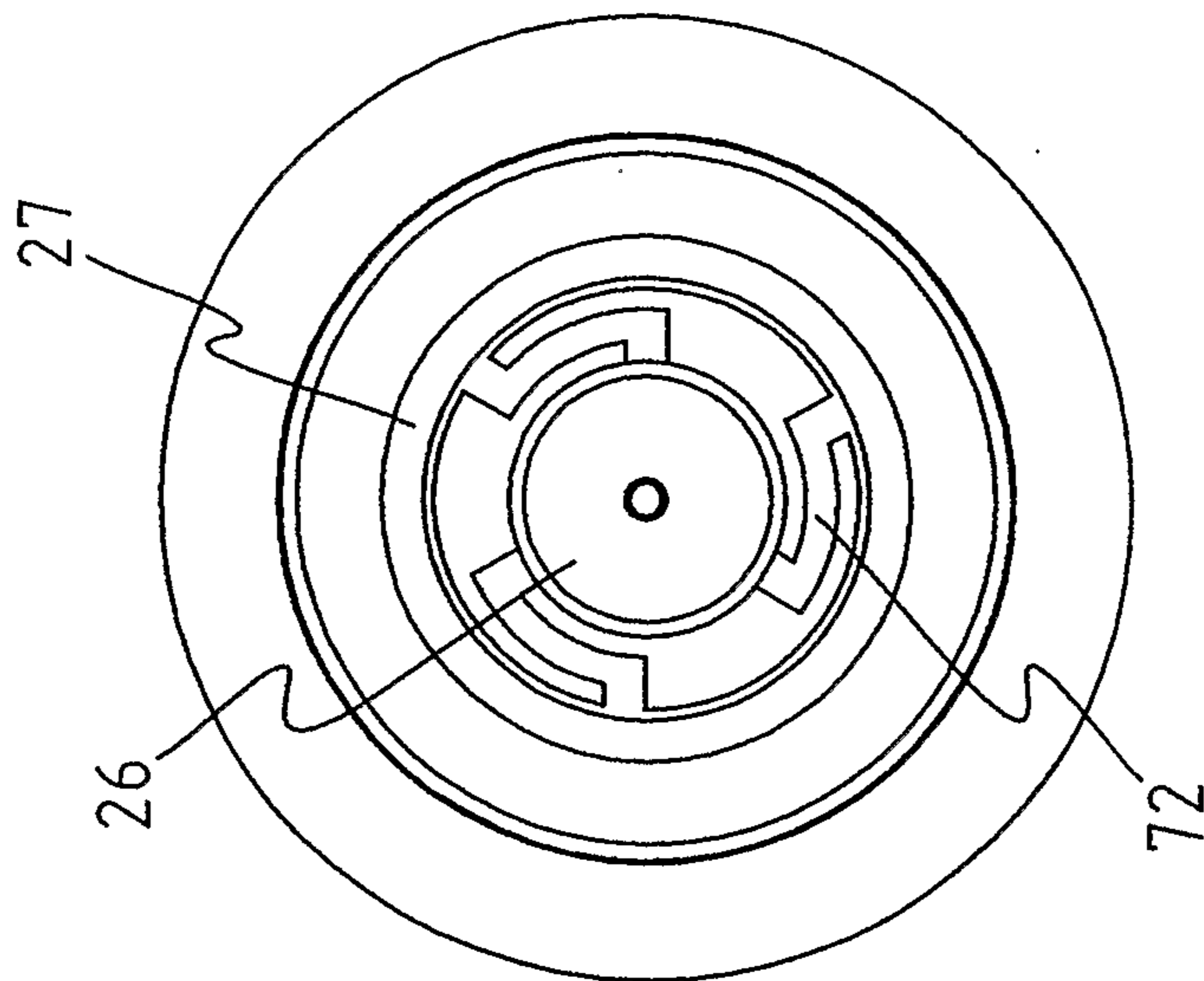

FIG. 8A

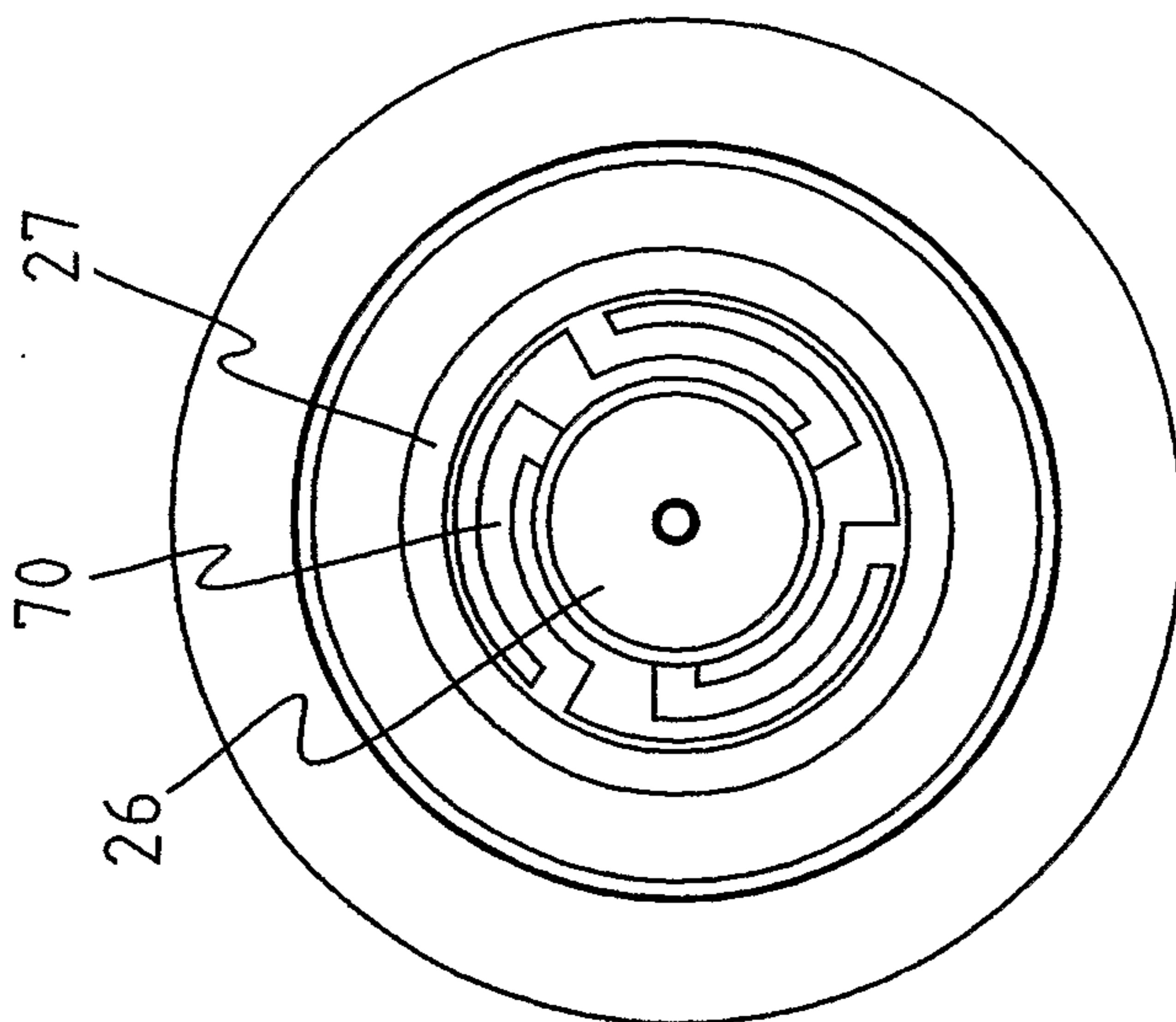

FIG. 8B

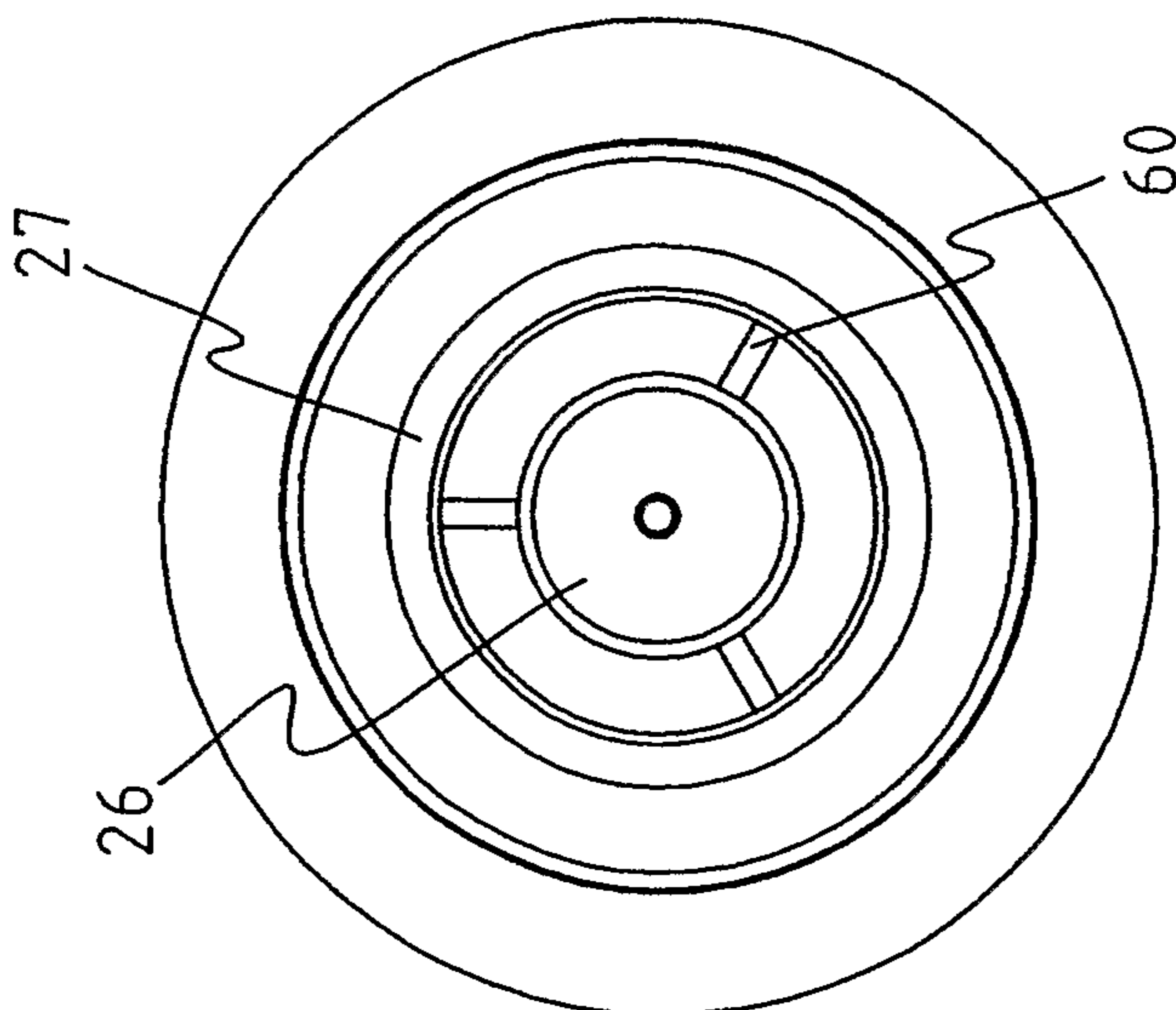

FIG. 8C

13/13

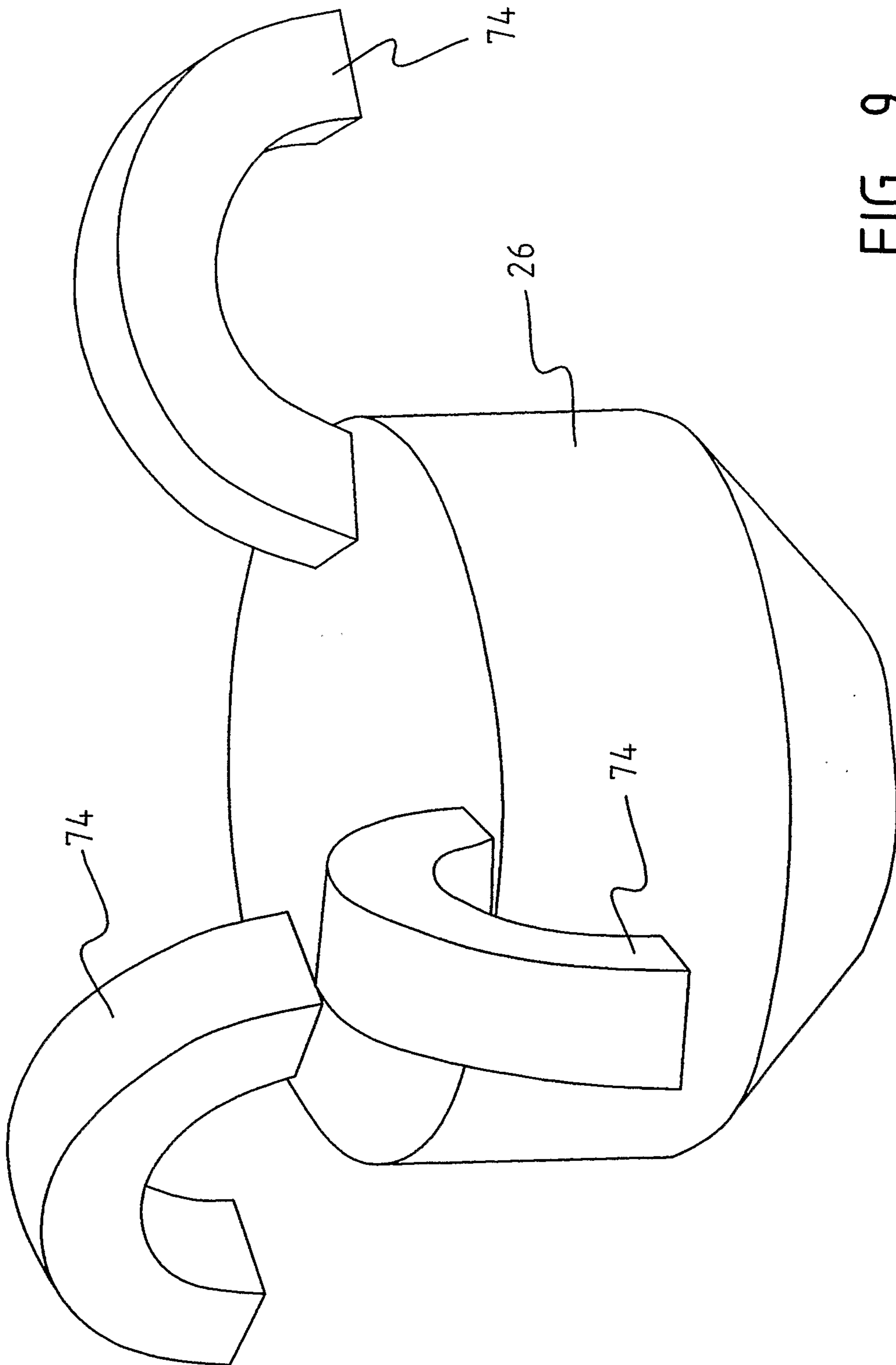

FIG. 9

