



(11) (21) (C) **2,092,462**
(22) 1993/03/25
(43) 1993/09/27
(45) 2000/10/24

(72) Fissmann, Hans-Joachim, DE

(72) Weiss, Hans, DE

(73) J.M. Voith GmbH, DE

(51) Int.Cl.⁵ B65H 18/20, B65H 18/26

(30) 1992/03/26 (P4209754.1) DE

(54) **BOBINEUSE POUR LE BOBINAGE D'UNE BANDE, EN
PARTICULIER UNE BANDE DE PAPIER**

(54) **WINDER FOR REWINDING A WEB, ESPECIALLY A PAPER
WEB**

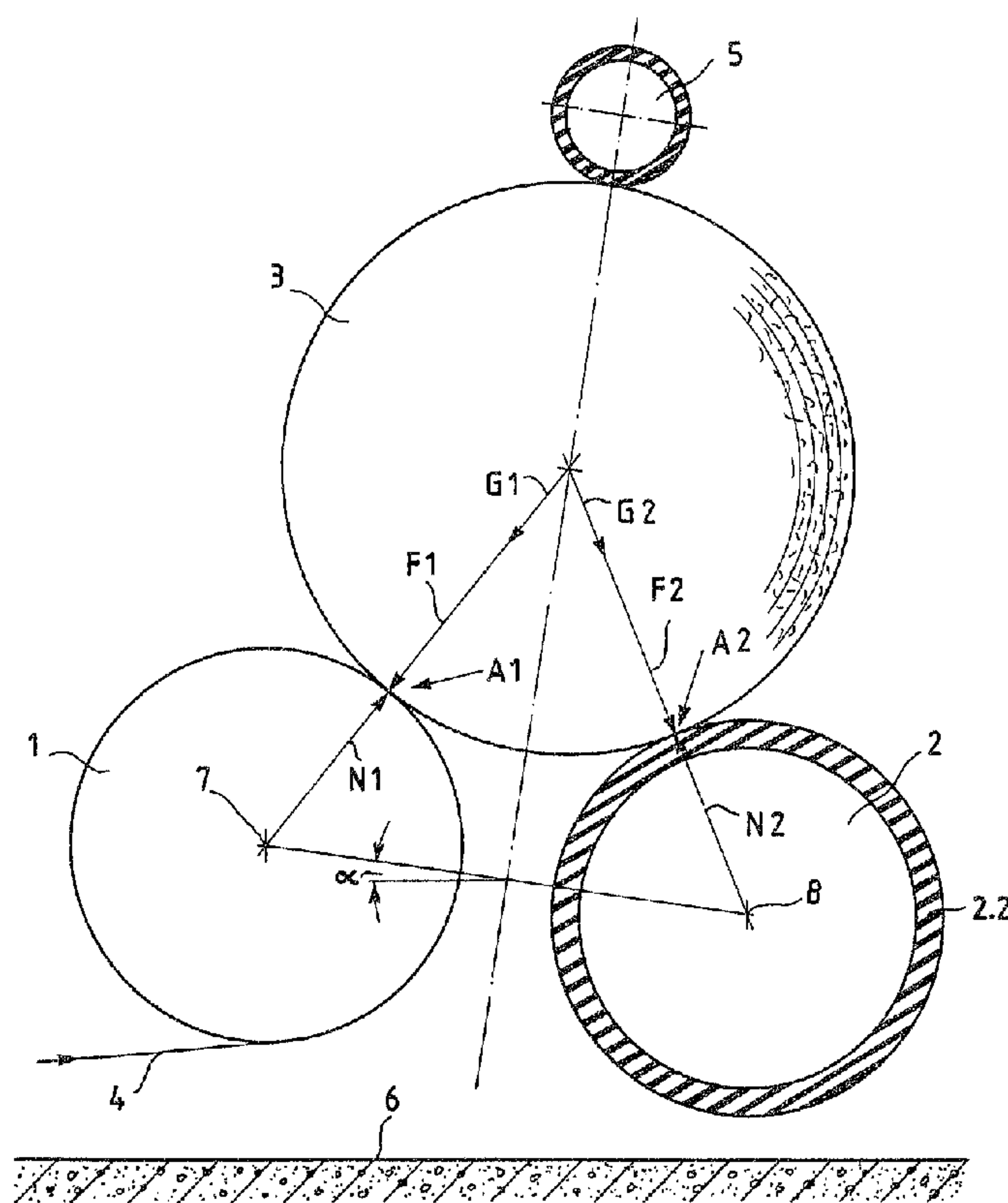

(57) This invention rollers to a winder for rewinding a running paper web with the following features: 1.1 Two support rollers that together form a winding bed to hold the paper roll; 1.2 The paper web is wound around one of the support rollers during operation; 1.3 The other of the two support rollers is lower than the first support roller so that a plane through the axes of the two support rollers from an angle with the horizontal. The invention is characterized by the following features: 1.4 The winding bed is exclusively of the support rollers 1.5 The second support roller has a liner that is considerably more deformable than the liner of the second support roller; 1.6 The two support roller are fixed in location



SUMMARY

5 This invention rollers to a winder for rewinding a running paper web with the following features:

1.1 Two support rollers that together form a winding bed to hold the paper roll;

10 1.2 The paper web is wound around one of the support rollers during operation;

1.3 The other of the two support rollers is lower than the first support roller so that a plane through the axes of the two support rollers from an angle with the horizontal.

15 The invention is characterized by the following features:

1.4 The winding bed is exclusively of the support rollers

1.5 The second support roller has a liner that is considerably more deformable than
20 the liner of the second support roller;

1.6 The two support roller are fixed in location

**Winder for Rewinding a Web
Especially a Paper Web**

Reference is made to the preamble of Claim 1.

5

In the winding of webs, the hardness of winding plays a role in subsequent processing. It is very critical especially for paper webs for the hardness of winding to have a definite progression over the whole diameter of the roll. In general, the hardness of winding should drop from a definite initial value to a final value. The decrease should be as uniform as possible from the first layer to the last. It should have a definite gradient, i.e., it should not be too strong and not too weak. The curve of rolling hardness should not in any case show discontinuities, for example a sudden decrease.

This is achieved only when certain measures are taken. If nothing is done, the linear pressure between the roll and the support roller or rollers will become greater and greater with increasing roll diameter, and thus also the hardness of winding.

To avoid this, for example, so-called rider rollers are used that are placed with axis parallel to the support rollers. These rider rollers exert pressure on the roll. The surface pressure is controlled, and is high at the beginning and becomes smaller with increasing roll weight

The rider roller thus provides control over the linear pressure and thus the hardness of winding, in the desired direction. However, if it is desired to produce a roll of very large diameter then the linear pressure is also very high in the final phase of rewinding. In the same way, the winding tension increases so that the web may tear or wrinkle.

Other steps for controlling the hardness of winding consist of distributing the load of the roll to the individual support rollers. Support rollers of the same diameter have been positioned at different horizontal levels for this purpose, or support rollers of different diameters are used.

30

- 2 -

It is also known that a harder winding is obtained when winding on a support roller of smaller diameter than when winding on a support roller of larger diameter.

A winder was disclosed by DE-DM 7 310 606 that has two support rollers of equal size.
5 One of these support rollers can be lowered during the winding process from an upper position above the horizontal plans of the axis of the other support roller at the beginning of the winding process. This lowering is intended to produce a core wound firmly from the beginning,

US-PS 2,461,387 describes a winder that has two driven support rollers of different
10 diameters; the support roller with the smaller diameter has a liner with higher friction factor and is driven at a higher speed than the other support roller. This exerts a tensile stress on the outer layer of the web,

DE-OS 27 57 247 relates to a winder with support rollers of equal diameters. The
15 hardness of winding is controlled by changing the distance between the support rollers.

DE-PS 678 586 describes a winder with two support rollers, of which the first has a
hard shell and the second a soft one. The axes of the two rollers are in one and the same
horizontal plane.

20 DE 38 39 244 describes a winder with three support rollers. The first support roller is stationary, with the two subsequent support rollers being changeable in position, and having a supporting belt wound around them. It is intended that the hardness of winding over the roll diameter can be controlled by the supporting belt and by changing the positions of the second
25 and third support rollers. The supporting belt is to produce the greatest possible supporting surface to lower the load per unit area. This winder is extraordinarily expensive. It also has a particularly serious drawback: When the paper roll has grown so that it is supported primarily by the supporting bell, the supporting belt may vibrate vigorously so that the paper roll begins to "dance" and can be catapulted out of its bed in this way.

30

- 3 -

It has also already been suggested in a winder with two support rollers that the shells of these two rollers be made of rubber. The support rollers had the same diameters in this case, and the rubber liner had the same hardness. However, this also leads to vibration and floating of the paper rolls.

5

EP 0 157 062 B1 describes a winder with two support rollers and one rider roller. The shell surfaces of all of these rollers consist of a number of individual fluid chambers that are located axially side by side, and whose individual shell surfaces constitute the entire shell surface of the roller in question with formation of a butt joint. The supporting behavior of such a roller is naturally nonuniform viewed over the width of the web because of the number of butt joints.

10

This invention proceeds from DE 3121039 C3, in which there are two support rollers arranged so that at least during a certain operating phase the central axis of one support roller lies below the central axis of the other support roller. In this prior publication it remains unanswered which of the two support rollers, i.e., the one around which the paper web is wound, or the one around which it is not wound, is the lower one.

15

The purpose of this invention is to design a winder pursuant to the preamble of Claim 1 in such a way that paper rolls can be produced with it that have an even larger diameter compared to known winders, so that the surface pressure (i.e., the maximum surface pressure on the support rollers) is limited as much as possible so that the hardness of winding does not rise disproportionately, and especially so that no splits, cracks, or folds occur during the winding, and also so that the cost of construction is kept within reasonable limits, and finally so that there is reliable guidance of the paper roll during the entire operation so that no vibration or "dancing" of the wound roll occurs.

20

25

This problem is solved by the characterizing features of Claim 1.

30

The inventors have chosen the correct combination from a number of known or

- 4 -

theoretically conceivable combinations of features. The two features that the second support roller in the running direction of the web (around which the paper web is not wound) is lowered relative to the first, and that just this roller has a relatively flexible roller liner that has the characteristics of a "wide-nip" roller.

5

This feature of greater softness or compliance can be implemented in various ways in practice. Examples of embodiment are familiar to one skilled in the art. Thus, for example, an elastic roller liner can be chosen, or the roller can be designed as a so-called floating roller that has a rigid yoke, a relatively thin roller liner, and a number of support elements that are provided between the yoke and the liner, or the roller can be made as a tube roller, provided that support by the support rollers is continuous all along the roller width, in contrast to EP 0 157 062 B1.

10

The invention can also be applied to winders with so-called alternating rewind. A machine-width paper web in this case is divided into a number of narrow strips and is rolled up alternately left and right on a vertical plane. The weight of the paper rolls can be relieved by clamping heads that grip the ends of the particular cores on which the individual paper rolls are rewound. There are limits to such relief, however, since the cores are destroyed beyond a certain weight.

20

The Invention provides the following capabilities;

There is a need to begin with weight relief by means of clamping heads only for larger roll diameters;

25

or it is necessary to apply only smaller relief forces;

or paper rolls with larger diameters can be made with equal relief up to the limit of core strength;

30

- 5 -

or simpler and thus cheaper winding cores can be used.

There are two basic versions with the mentioned alternate rewind: The first version uses three support rollers, namely a central roller and two satellite rollers to the left and right. The
5 second version provides for only a single supporting roller.

The invention can also be applied to the first version. Specifically, pursuant to a characterizing feature, the individual winding bed is composed exclusively of two support rollers.
10

It should be avoided that the two support rollers have the same diameters, and at the same time have the same rubber hardness. The two support rollers can thus definitely have some elasticity in their liners.

15 However, the extent of elasticity should be different.

The invention and the state of the art are explained in detail in the drawing. In detail, the drawing shows the following:

20 Fig. 1 shows a winder pursuant to the invention in schematic illustration and in elevation.

Figs. 2 to 4 show the construction of the second (soft) support roller pursuant to the invention.
25

Fig. 5 in turn shows another embodiment of a winder pursuant to the invention in schematic illustration and in elevation.

Fig. 5a at the top shows a support roll 2 in cross section (perpendicular to the axis)
30 and in longitudinal section (parallel to the axis). This has an internal yoke 70 and roller

- 6 -

liner 71 that is clamped in caps 72 on the face (only one shown). The annular space 73 between the yoke 70 and the liner 71 can be inflated.

Fig. 5b shows another embodiment of a winder pursuant to the invention
5 schematic illustration and in elevation in which an encircling belt is wound around the support roller 2.

Fig. 5c in turn shows a winder in elevation and in schematic illustration in which a
10 belt is wound around both support rollers 1, 2.

Fig. 6 is a review illustration of 22 different roller configurations pursuant to the state of
the art and also pursuant to the invention.

The winder illustrated in Fig. 1 has two support rollers 1 and 2 that together constitute a
15 winding bed to hold a paper roll 3. The paper roll 3 is formed by rewinding a paper web 4. It can be seen that the web 4 is fed from the left bottom and first winds around the support roller 1. The paper roll 3 is loaded in a controllable manner by a load or rider roller 5 so that it also controls the surface pressure.

20 It can also be seen that the support roller 1 is at a higher level above the base 6 than the support roller 2. The axis 7 of support roller 1 and the axis 8 of support roller 2 are in a plane that forms an angle α with the horizontal. This angle α is an acute angle in every case. In the present case it is about 5° . In practice, far higher values can also be provided for, for example 30° . The preferred range is 0.5 to 20° .

25 It is also important for the support roller 2 to have a liner that is more severely deformable than the liner of support roller 1. In the present case, the material of support roller 1 is steel while the liner 2.2 of support roller 1 (sic) is made of rubbery flexible material.

30

- 7 -

Because of the sloping arrangement, the weight G of the paper roll 3 is distributed differently to the two support rollers 1 and 2. The component G_2 of the weight of the paper roll is obviously larger than the component G_1 . Accordingly, the support area A_2 on the support roller 2 is also larger than the support area A_1 on the support roller 1. In the present case, for example, A_2 could be considered equal to $1.6 \times A_1$.

The following conditions are desirable:

$$N_1 = F_1 < N_2 + F_2$$

$$P_1 = N_1/A_1$$

$$P_2 = N_2/A_2$$

$$P_1 = P_2 \text{ (desired)}$$

The symbols mean the following.

N = Force perpendicular to the liner of the support roller

F = Force of reaction on the paper roll

P_1 = Surface pressure on the support roller 1

P_2 = Surface pressure on the support roller 2

Because of the arrangement and configuration of the winder pursuant to the invention it is possible to achieve a distinctly larger paper roll diameter than has been possible in the past. A diameter of about 1400 mm can be reached with the winder describe here, instead of up to 1200 mm in the past.

The support rollers shown in Figures 1 to 4 are possible variance of the liner of the support roller 2.

- 8 -

In the form of embodiment according to Fig. 2, the liner first has an outer layer 20 that has a continuous surface. This layer 20 can be steel, rubber, or another material. A helically circling coil is wound into the substance 21 of the liner so that a bridge 22, likewise circling helically, remains. A tube 23 that can be inflated is inlaid in the coil. Instead of a single tube, several tubes may naturally also be provided.

The liner according to Fig. 3 has an outer layer 30 made of rubber and an inner layer 31 made of steel. Many chambers 32 are provided in the rubber layer, which are circular viewed in cross section A-A.

The form of embodiment according to Fig. 4 shows a liner that is made up of three different layers, namely from outside to inside, a hard rubber layer 40, a soft rubber layer 41, and a steel body 42.

In the form of embodiment according to Fig. 5b, a stationary pressure element 2 is provided instead of a rotating support roller, and also an encircling belt 50 and a rotating guide roller 51. The belt 50 is wound around both the stationary support element 2 and the rotating guide roller 51. The stationary support element 2 has shoe elements 52 that can be pressed against the inner surface of the rotating belt 50 by pneumatic or hydraulic pressure and can thus generate a pressure. This pressure is distributed over a larger area viewed in the direction of rotation of the belt 50 and also of the paper roll 3, so that the pressure per unit area is relatively small. A lubricating mechanism 53 reduces the sliding friction between the belt 60 and the stationary support element 2.

Finally, Fig. 6 shows a number of variants, a total of 22, of which only Variants I, II, and III represent configurations pursuant to the invention.

The first support roller 1 will usually have a steel liner. However, it can also have a rubberized liner. It is important for the nature of the liner of the second support roller to be such that a "wide-nip effect" is obtained on the second support roller with regard to the first.

PATENT CLAIMS

1. Winder for rewinding a running paper web (4) with the following features:

5 1.1 Two support rollers (1, 2) that together form a winding bed to hold the paper roll (3);

1.2 The paper web (4) is wound around one of the two support rollers (support roller 1) during operation;

10 1.3 The other of the two support rollers (2) is lowered relative to the first support roller (1) so that a plane through the axes of support rollers (1,2) forms an angle with the horizontal;

15 characterized by the following features:

1.4 The winding bed is composed exclusively of the two support rollers;

20 1.5 The second support roller (2) has a liner that is considerably more deformable than the liner of the first support roller (1);

1.6 The two support rollers are fixed in location

25 2. Winder pursuant to Claim 1, characterized by the fact that the diameter support roller (2) is about 1.05 to two times the diameter of support roller (1).

3. Winder pursuant to Claim 1 or 2, characterized by the fact that the angle between the plane through the axes of the support rollers and the horizontal is between 1 and 20°.

30 4. Winder pursuant to one of the claims 1 to 3, characterized by the fact that

- 10 -

at least the outer layer of the liner of support roller (2) consists of rubber and that the rubber hardness is between 30 and 120° P&J.

5. Winder pursuant to one of the Claims 1 to 4, characterized by the fact that
5 outer layer of support roller 1 has a liner made of elastic material.

6. Winder pursuant to one of the Claims 1 to 5, characterized by the fact that support roller 1 and support roller 2 have an outer liner layer of elastic material and that the elasticity of this layer is greater in support roller 2 than in support roller 1.

Fig. 1

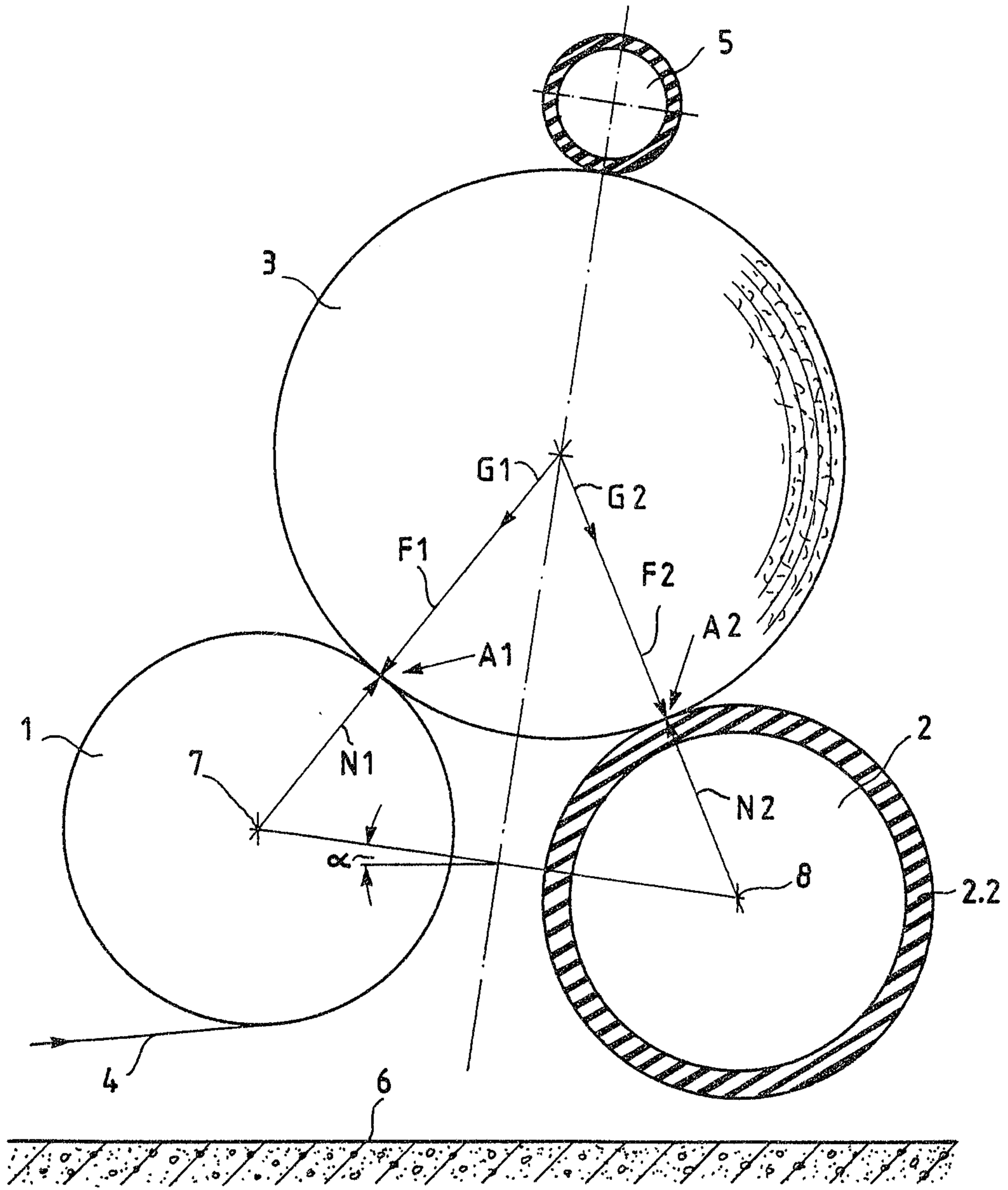

Sent to: M. C. Bunnell

Fig. 2

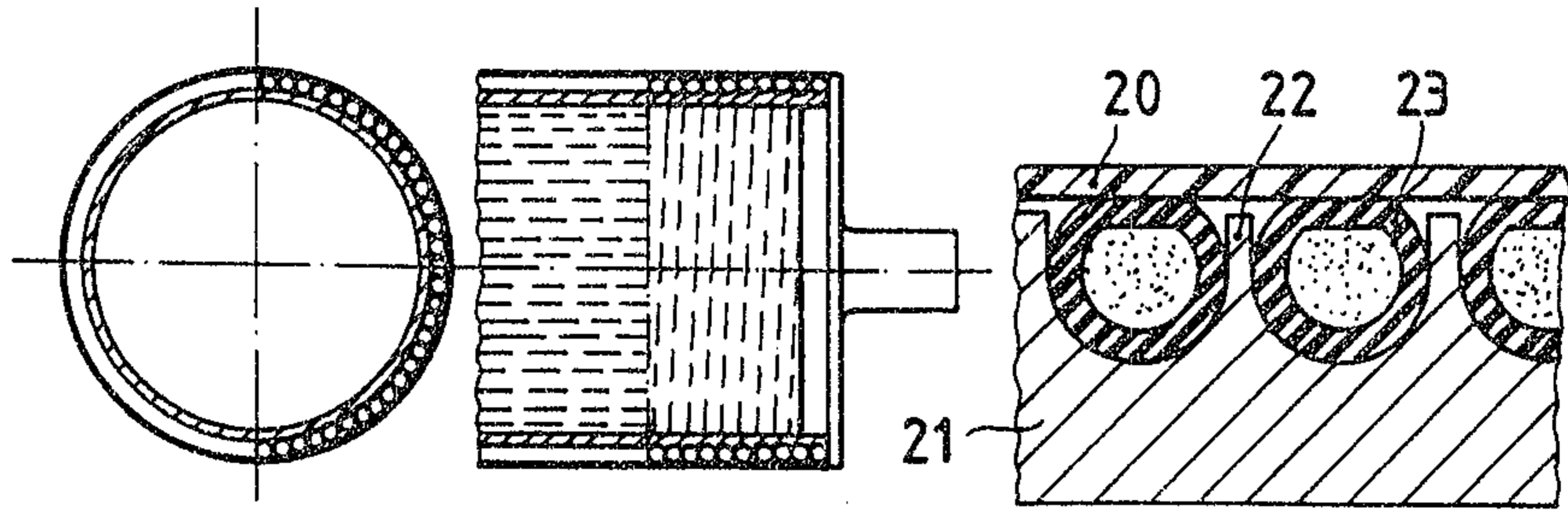

Fig. 3

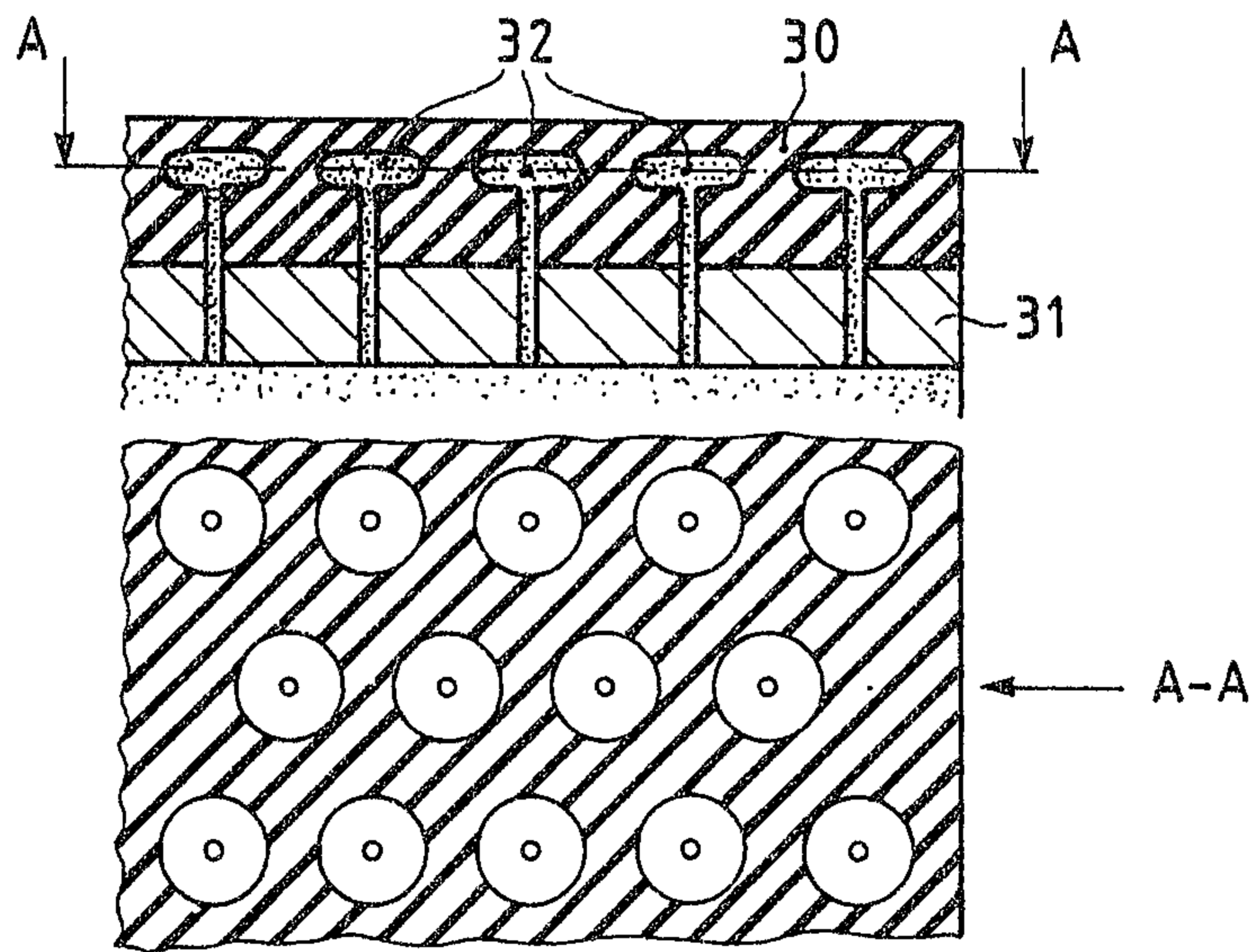
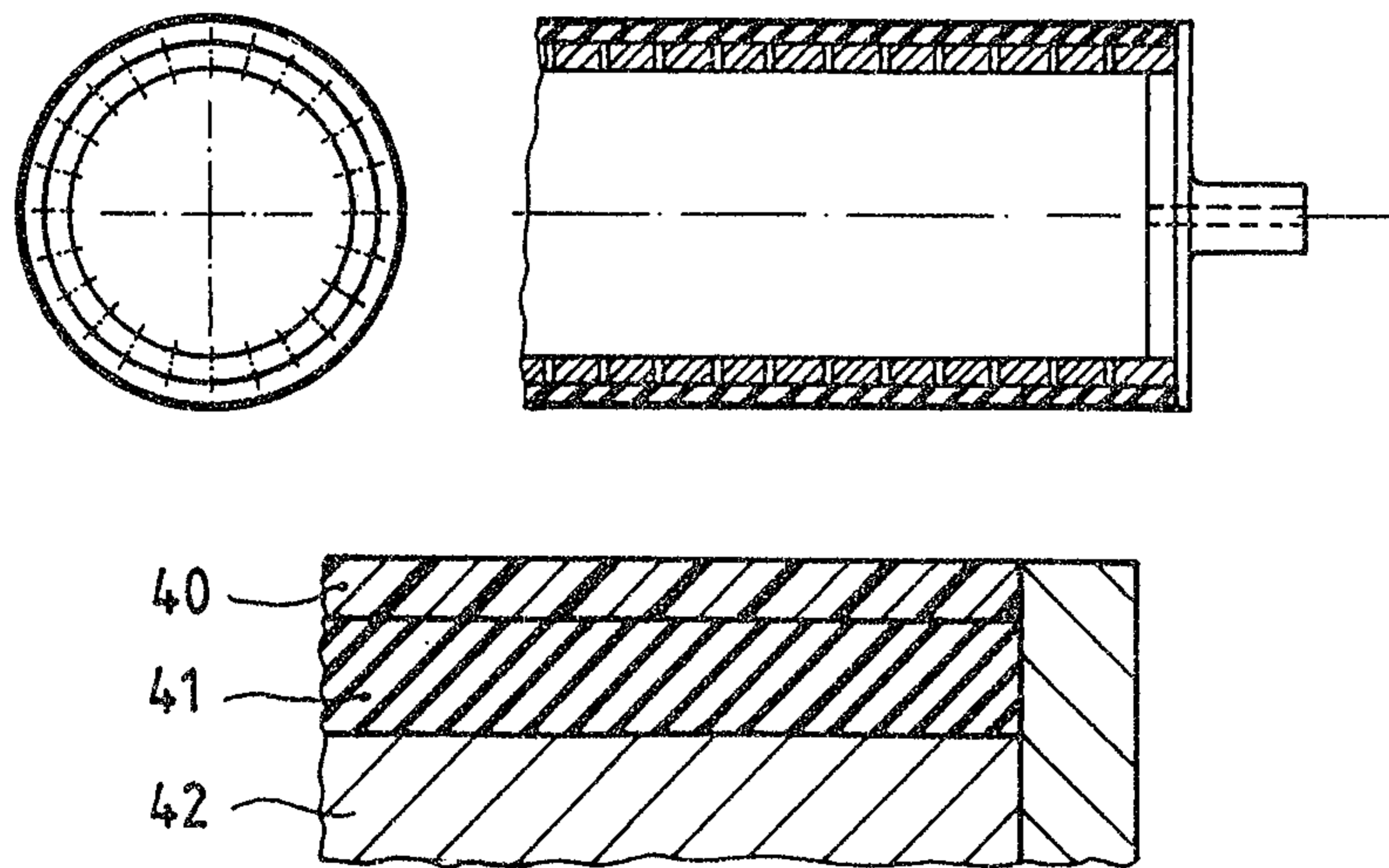

Fig. 4



Send to Mr. Bureau

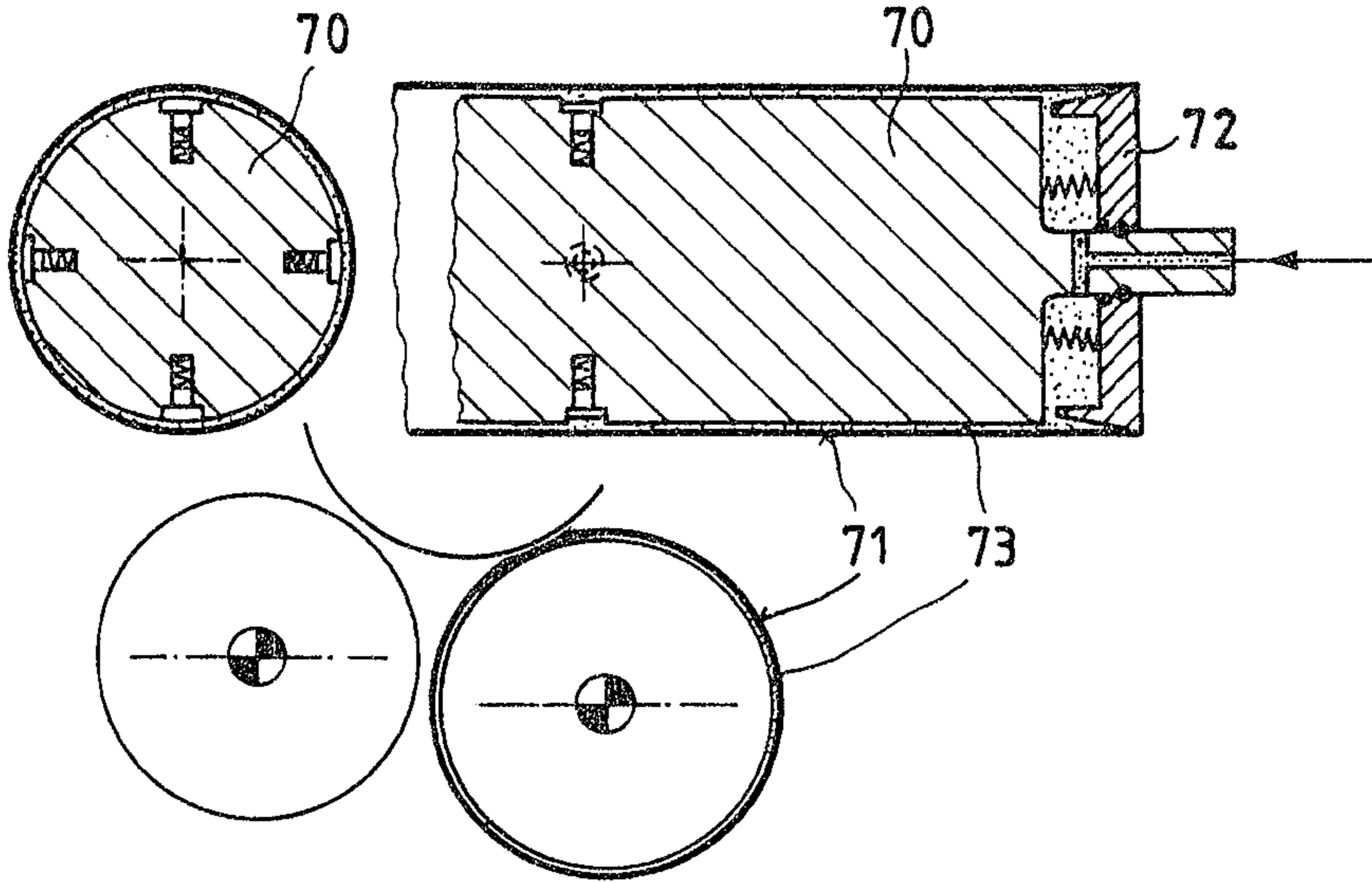

Fig. 5a

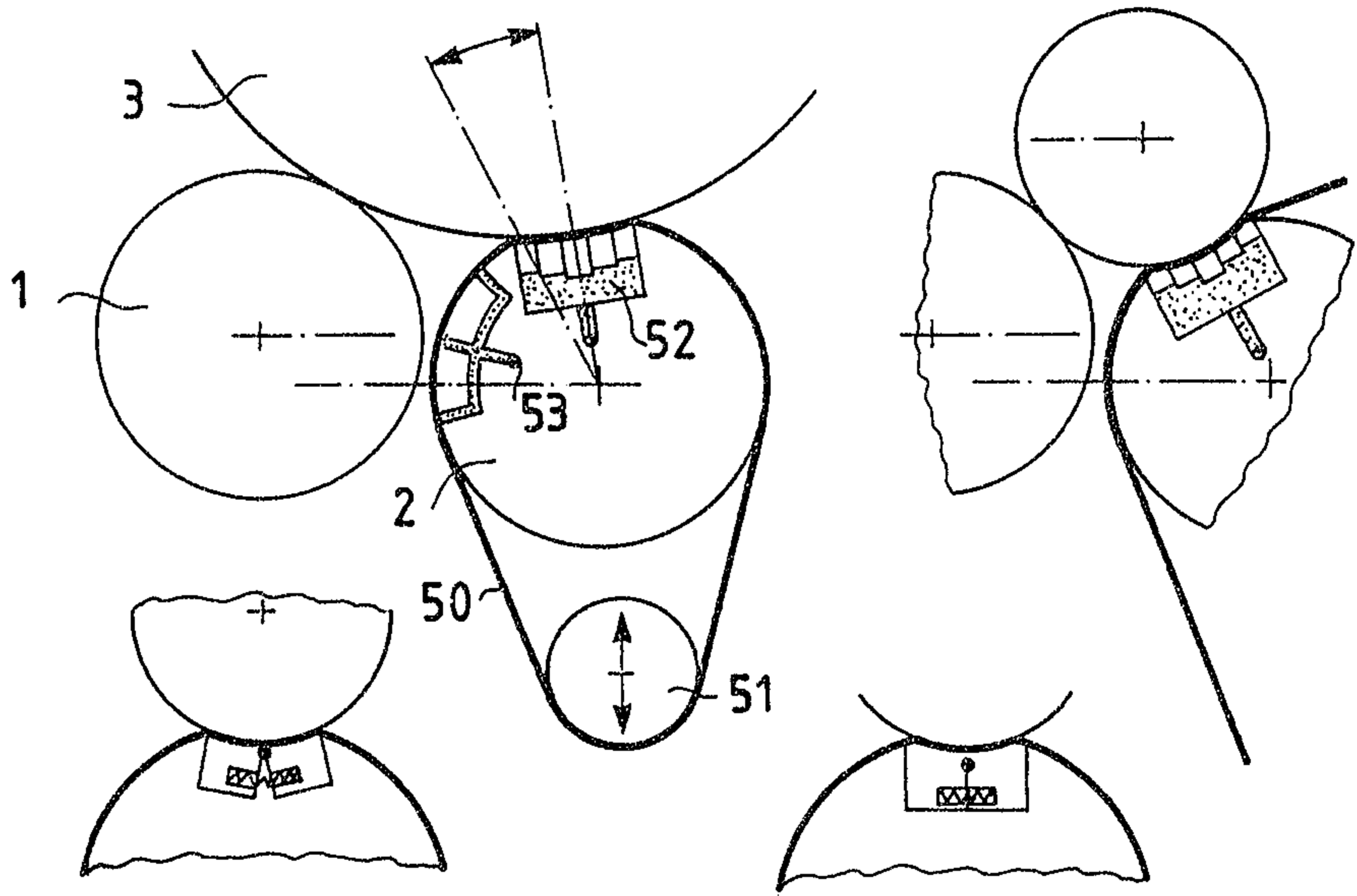

Fig. 5b

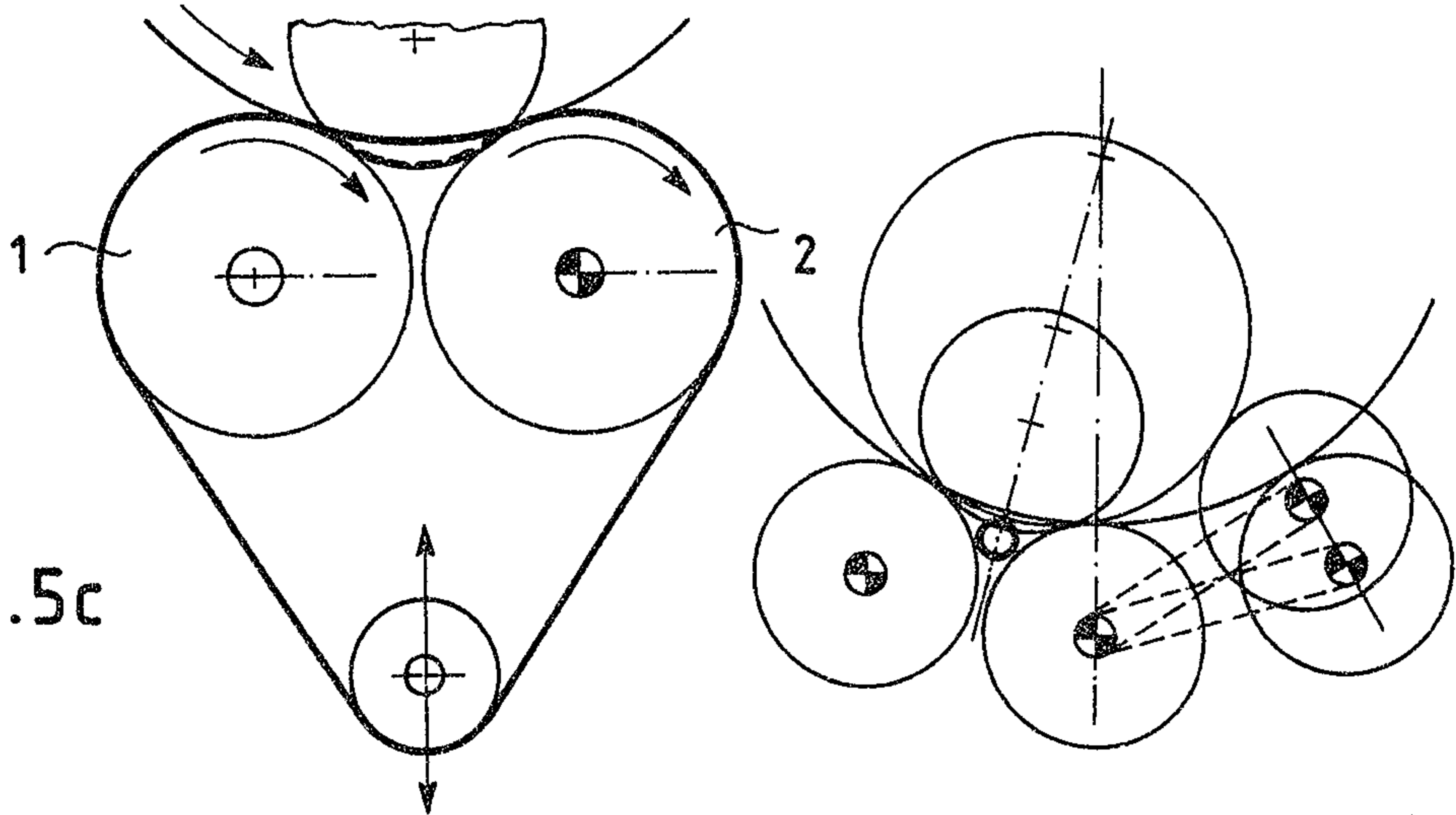

Fig. 5c

Per. 1 Mc. Burney

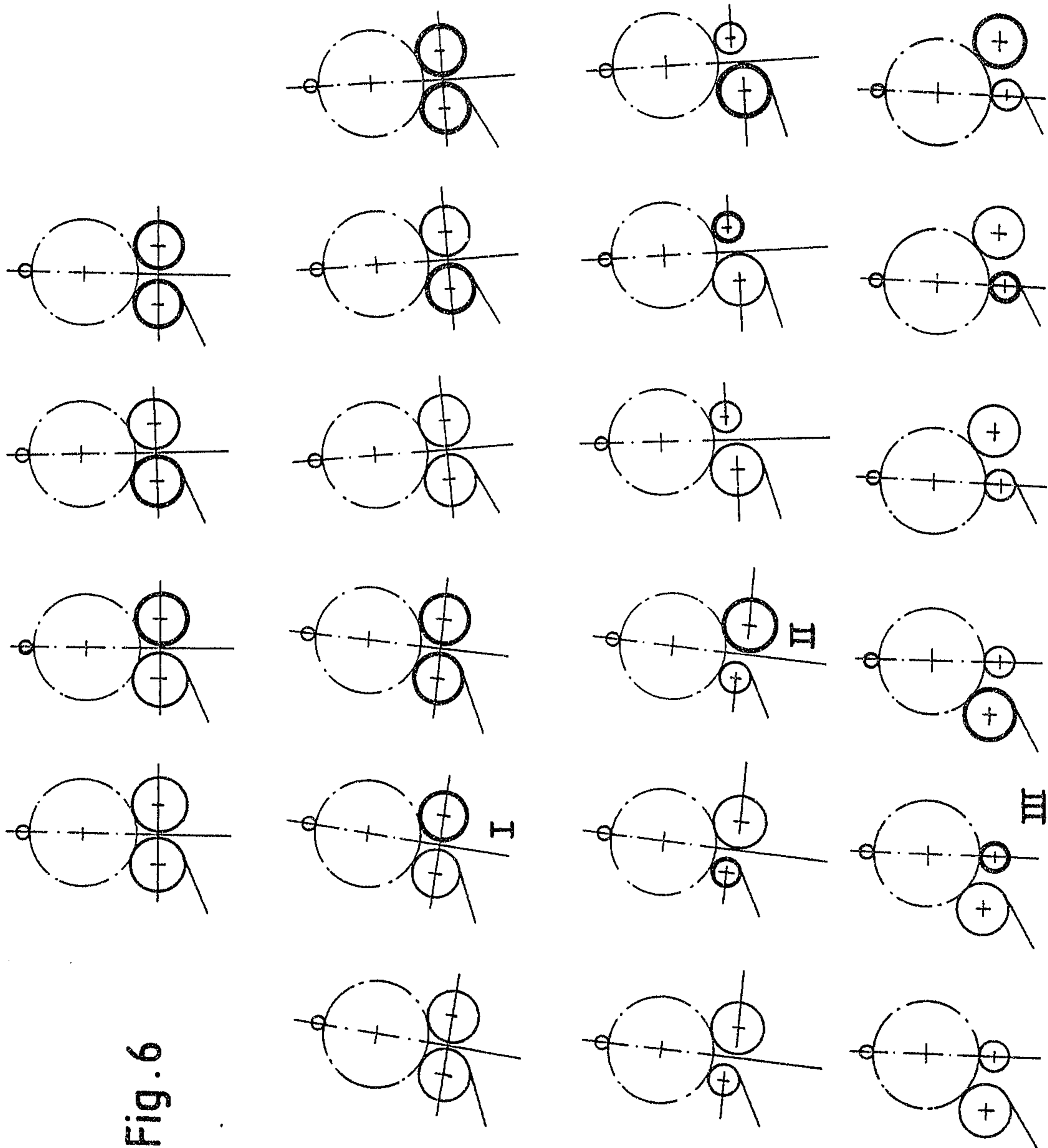

Fig. 6

Des. ¹/₂ M. Burnaf

