

G. W. HART.  
 MEANS FOR CONTROLLING ELECTRIC CIRCUITS.  
 APPLICATION FILED FEB. 21, 1910.

999,781.

Patented Aug. 8, 1911.

3 SHEETS—SHEET 1.

Fig. 1.

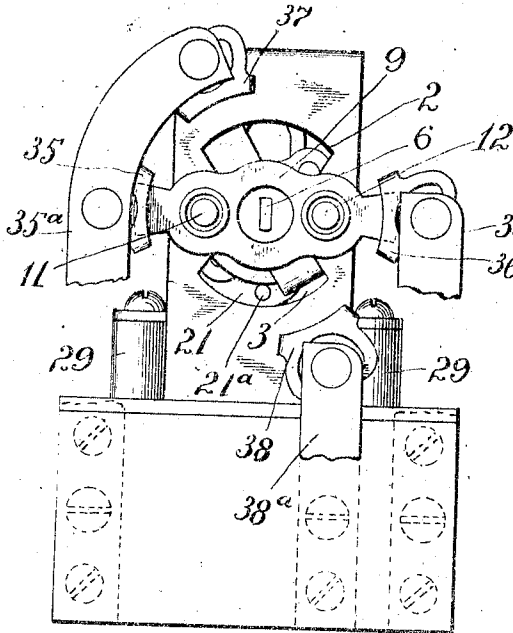

Fig. 2.

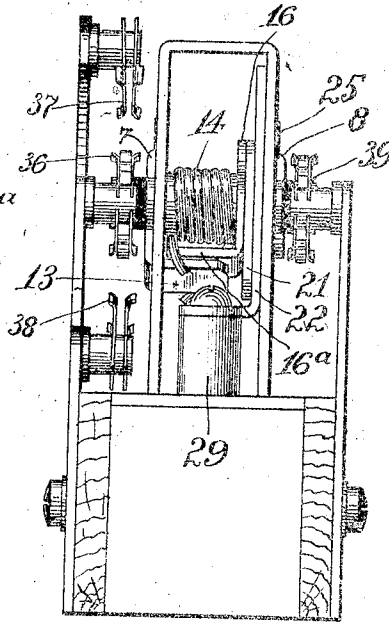

Fig. 4.

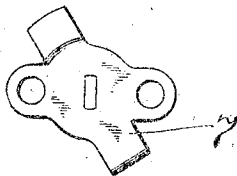
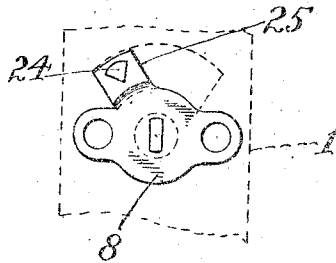

Fig. 5.



Witnesses:

*Fred M. Kammelfelser.*  
*Chas. A. Peard*

Inventor

G. W. HART

By his Attorneys  
*Barrett, Pomeroy & Mitchell*

G. W. HART.  
 MEANS FOR CONTROLLING ELECTRIC CIRCUITS.  
 APPLICATION FILED FEB. 21, 1916.

999,781.

Patented Aug. 8, 1911.  
 3 SHEETS—SHEET 2.

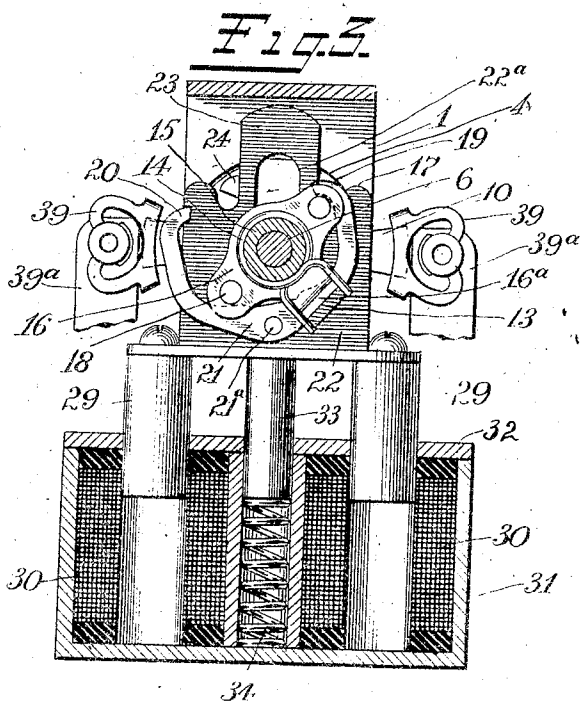

Fig. 6.

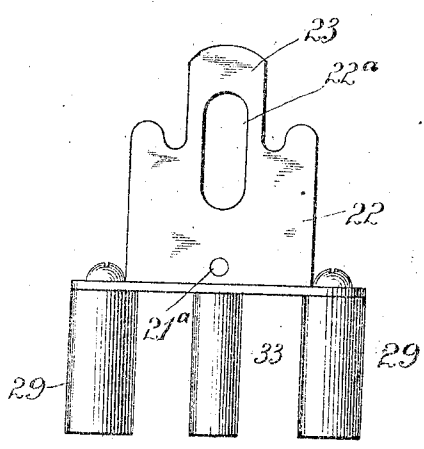
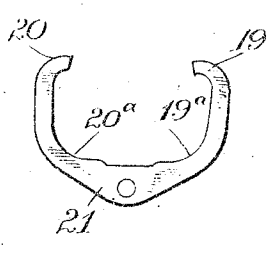

Fig. 7.



Witnesses:  
*Paul H. Danneberg*  
*Charles Paul*

Inventor  
 G. W. HART  
 By his Attorneys  
*Barrett, Maxwell & Co.*

G. W. HART.  
 MEANS FOR CONTROLLING ELECTRIC CIRCUITS.  
 APPLICATION FILED FEB. 21, 1910.

999,781.

Patented Aug. 8, 1911.

3 SHEETS—SHEET 3.

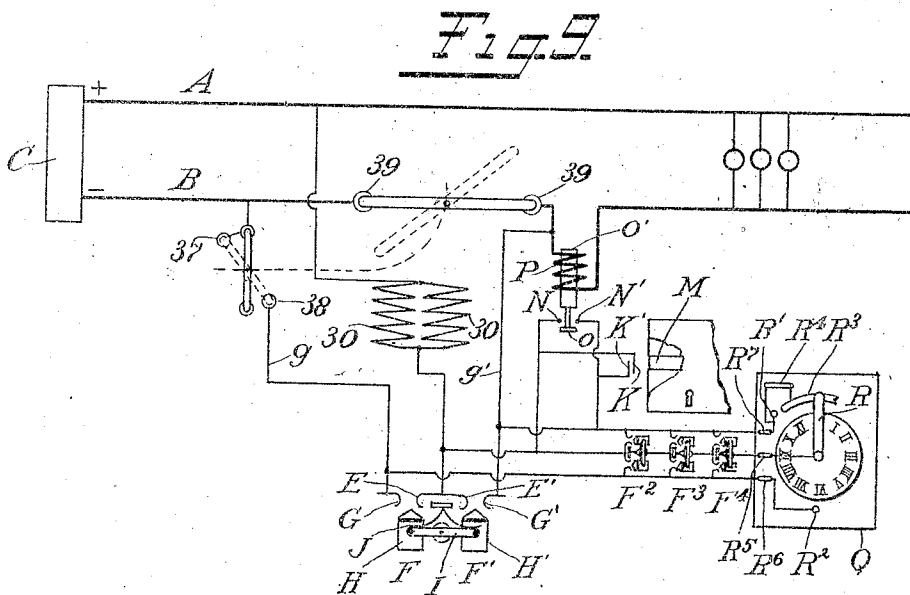
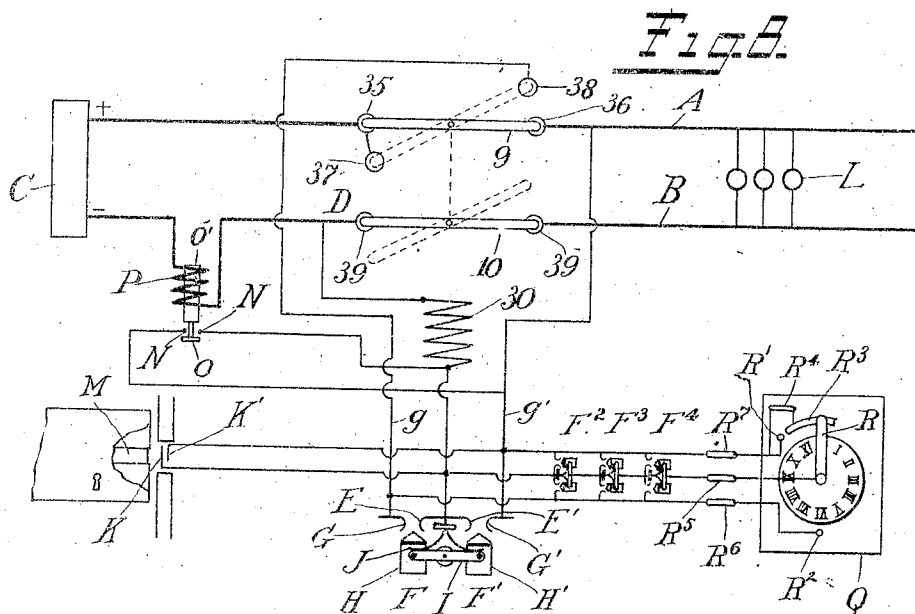

Witnesses:  
 Fred W. Dannenfelser.  
 Chas. W. Ward

Inventor  
 G. W. HART.  
 By his Attorneys  
 Bartlett, Brown & Mitchell

# UNITED STATES PATENT OFFICE.

GERALD W. HART, OF WEST HARTFORD, CONNECTICUT, ASSIGNOR TO THE HART MANUFACTURING COMPANY, OF HARTFORD, CONNECTICUT, A CORPORATION OF NEW JERSEY.

MEANS FOR CONTROLLING ELECTRIC CIRCUITS.

999,781.

Specification of Letters Patent. Patented Aug. 8, 1911.

Application filed February 21, 1910. Serial No. 545,158.

To all whom it may concern:

Be it known that I, GERALD W. HART, a citizen of the United States, residing at West Hartford, county of Hartford, State of Connecticut, have invented certain new and useful Improvements in Means for Controlling Electric Circuits, of which the following is a full, clear, and exact description.

My invention relates to means for controlling electric circuits, and has for its object to produce a new and efficient means of controlling such circuits electro-magnetically by current from the circuit controlled.

It further has for its object to provide means for doing this through a single winding, and to provide means whereby this winding can be energized whether the switch is opened or closed, but will be open-circuited by the subsequent action of the switch in either instance.

It further has for its object to provide various means for controlling said winding.

The following is a description of an embodiment of my invention, reference being had to the accompanying drawings, in which,

Figure 1 shows a front elevation of a switch mechanism adapted to be used to carry out my invention. Fig. 2 shows a side elevation of the same, without the stationary contacts. Fig. 3 shows a longitudinal section of the same. Fig. 4 shows in detail a spring plate. Fig. 5 shows in detail the detent restraining the switch arms from movement while their actuating spring is being put under tension. Fig. 6 shows in detail the actuating member. Fig. 7 shows in detail the grab hook. Fig. 8 shows diagrammatically one embodiment of my invention. Fig. 9 shows diagrammatically a modification of the same.

Referring more particularly to the drawings, 1 is the support for the switch mechanism having on one side curved slots 2-3 and on the other side a curved slot 4 for the purpose hereinafter described. Journalled in the support 1 is a shaft 6, having on one end a spring plate 7 and on the other end a detent plate 8. The ends of the shaft pass through rectangular openings in these plates and are headed over so as to secure them rigidly thereto. The plates 7 and 8 are on opposite sides of the support 1. To the plates 7 and 8 respectively are secured switch arms 9 and 10 by insulating bush-

ings 11 and 12. An arm 13 extends from the spring plate 7 through the slot 3, so as to be engaged by the two ends of a spring 14 surrounding a sleeve 15 upon the shaft 6. The sleeve 15 has rigidly secured to it a rock arm 16, having at its opposite ends rearwardly projecting studs 17-18. These studs 17-18 are adapted to be engaged by hooks 19-20 of a gripping member 21, which is carried by the actuating member 22, being pivoted thereto at 21<sup>a</sup>. This actuating member is provided with a restraining plate or extension 23, which lies in the path of a projection or detent 24 upon the detent plate 8, the projection 24 extending through the slot 4 in the rear of the support 1. The arm 25 of the detent plate is bent inward so as to travel in the same plane as the rear portion of the support 1, and engage the extremities of the slot 4 at each end of its throw, thereby definitely limiting the movement of the shaft 6 in each direction. The actuating member is provided with a slot 22<sup>a</sup>, through which the shaft 6 passes, and at its lower end is provided with magnetic cores 29, which extend into a solenoid 30. This solenoid is inclosed in an iron box 31 having an iron cover 32, and so are "iron-clad". The cores 29 pass through openings in the cover. The actuating member 1 also carries a projection 33, which passes through an opening in the cover 32 and engages a spring 34, which spring returns the actuating member 22 to initial position when the winding 30 is deenergized.

The rock arm 16 carries a spring engaging arm 16<sup>a</sup>, which also lies between the ends of the spring 14. The switch arm 9 when in one position engages stationary circuit contacts 35-36 carried by supports 35<sup>a</sup>-36<sup>a</sup>, and in its other position engages contacts 37-38. The contact 37 is carried by the support 35<sup>a</sup>, while the contact 38 is carried by an independent support 38<sup>a</sup>. The switch arm 10 when in one position engages contacts 39 carried by supports 39<sup>a</sup>. The distance between contacts 35 and 37 and between contacts 36 and 38 is such that the arm 9 breaks engagement with 35 and 36 before making engagement with 37 and 38, and vice versa.

The upper end of the slide plate 23 forms the arc of a circle, which, when the slide plate is depressed, has as its center the axis of the slide 6, and whose radius is equal to

the distance between said axis and the in-  
most part of the detent. The engagement  
of the detent with the upper end of the slide  
plate 23 prevents the slide plate from mov-  
ing longitudinally toward its initial posi-  
tion, so that the member 22, when de-  
pressed, is held depressed until the switch  
arm has completed its full throw. Tension  
is thus maintained on the spring 14 until its  
work is completed.

The above mechanism operates as follows:  
When the winding 30 is energized, the cores  
29 are pulled downward, thereby moving  
the actuating member 22 and the hook mem-  
ber 21 downward. If the hook 19 is in en-  
gagement with the pin 17 at this time, as  
shown in Fig. 3, it causes the rock arm 16  
to turn to the right, putting the spring 14  
under tension. The spring plate 7 is, how-  
ever, prevented from movement, so long as  
the detent 24 engages the vertical side of  
the restraining plate 23. When the actu-  
ating member has moved down sufficiently to  
cause the restraining plate 23 to pass out of  
the path of the detent 24, the detent 24  
passes over the top of the restraining plate  
23, and at the same time the shaft 6 and the  
switch arms 9 and 10, being all rigidly  
connected to the detent 8, turn through a  
corresponding angle under the impulse of  
the spring 14. When the winding 30 is de-  
energized, the spring 34 returns the actu-  
ating member 1 to normal position, where-  
upon the projection 17 engages the lower  
portion 19<sup>a</sup> of the gripping member 21,  
causing it to tilt toward the right until the  
hook 20 grips the projection 18 upon the  
rock member 16. In Fig. 3, the pin 18 has  
just engaged the lower portion 20<sup>a</sup> of the  
gripping member, and caused the hook 19 to  
engage the pin 17. When the hook 20 has  
engaged the pin 18, the energizing of the  
winding 30 will cause the actuating member  
22 to move downward, carrying with it the  
gripping member 21, which will cause the  
rock arm 16 to turn toward the left, placing  
the spring 14 under tension in the opposite  
direction, the shaft 6 and the switch arms 9  
and 10 being meanwhile prevented from  
movement by the engagement of the detent  
24 with the right hand vertical face of the  
restraining plate 23. When the restraining  
plate 23 has reached its lowermost position,  
the detent 24 will move over the top of the  
plate 23 in a direction from right to left, to-  
gether with the shaft 6 and the switch arms  
connected thereto under the impulse of the  
spring 14. When the actuating member is  
again returned to normal position by the  
spring 34, the pin 18 will engage the lower  
surface 20<sup>a</sup> of the gripping member and tip  
it toward the left until the hook 19 engages  
the pin 17, as shown in Fig. 3.

Fig. 8 shows the switch mechanism above  
described connected to circuits so as to em-

body my invention in a double-pole switch.  
In this figure, A—B are branches of a cir-  
cuit supplying translating devices, L—L.  
C is a source of current. The winding 30  
has one terminal permanently connected to  
the source of current at a point D on the  
generator side of the switch. Its other ter-  
minal is connected to contacts E—E' of  
local circuit controllers F—F'. The sec-  
ond contact G' of the local controller F' is  
permanently connected by the conductor g'  
to the main A. The second contact G of  
the local controller F is connected by the  
conductor g to the contact 38, and through  
the switch arm 9 when the main circuit is  
open to the contact 37, which is permanently  
connected to the main A. The circuit be-  
tween the contact G and the main A is there-  
fore opened and closed according to the po-  
sition of the switch arm 9. The local con-  
trollers F—F' have push buttons H—H',  
which are independent, being connected to-  
gether by a pivoted lever I, which is nor-  
mally held by a spring J in a position such  
that there is no electrical connection be-  
tween the contacts E' and G' or E and G.  
When the main switch is closed, pushing  
the button H' so as to electrically connect  
the contacts E and G produces no result,  
since the local circuit in which these con-  
tacts are situated is broken at the switch  
arm 9. If, however, the button H' is  
pushed, the contacts E' and G' are electri-  
cally connected and the circuit is completed  
through the coil 30. This pulls down the  
actuating member 22 carrying the grab  
hook 21, causing the rocking lever to turn  
in a direction to open the switch. As soon  
as the switch opens, the circuit through the  
coil 30 is broken at the switch arm 9 and  
the coil becomes deenergized, permitting  
the actuating member to return to normal  
position as soon as the detent has passed  
across its upper end. A subsequent push  
of the button H' produces no result, since  
the circuit through the coil is now broken  
at the switch arm 9. The throwing of the  
switch mechanism not only actuated the  
switch arm 9, but also actuated the arm 10  
so as to cause it to disengage the contacts  
39—39, thus interrupting at two points the  
circuit between the translating devices and  
the source. The movement also brings arm  
9 into engagement with contacts 37 38, com-  
pleting a conducting path between the con-  
tacts E, G. When, therefore, the button H  
is pushed, with the switch arm 9 in open  
position, a local circuit is completed through  
the coil 30, again actuating the switch mech-  
anism, the arm 9 being in engagement with  
the contacts 37 and 38. The grab hook 21  
engages the rocking member so as to cause  
it to rotate in the opposite direction, and  
thus throws the switch mechanism in the  
opposite direction, causing it to open the

main circuit, and at the same time close the circuit between the contacts 37 and 38 in the local circuit of the controller F. The switch mechanism may also be controlled by other means than the push buttons H—H'. Thus, contacts K—K' may be provided, connected respectively to the conductors leading from the contacts E' and G', and adapted to be closed when the bolt M of a door lock is thrown, being situated in the door jamb for that purpose. The effect of this is that if the switch arms 9 and 10 are in closed position, and the door of the room is locked, so as to throw the bolt, the coil 30 will be energized so as to open the switch. In case the main switch is open and the bolt M is so thrown, no effect is produced, since the circuit which would otherwise be made through the coil 30 is open at the switch arm 9. Moreover, the conductors, connected to the contacts E' and G', may also be connected to contacts N and N' controlled by a contact O carried by a core O' of a solenoid P, which is connected to one of the mains A or B, so as to be in series with the lamps L. If the switch arms 9 and 10 are then in closed position, and for any reason the circuit becomes overloaded by reason of anything which takes place on the translating device side of the switch, the solenoid core will be lifted so that the contact O engages the contacts N and N', thus completing the circuit through the coil 30 and operating the switch mechanism so as to throw the switch arms 9 and 10 to open position. There may be a plurality of local circuit controllers such as F—F' connected in multiple at various points, as indicated at F<sup>2</sup> F<sup>3</sup> F<sup>4</sup>, so that the switch mechanism can be controlled from any desired number of points by the use of simple controlling circuits and local circuit controllers. The switch mechanism may also be controlled by a time mechanism, indicated at Q, in which clockwork rotates a switch arm R electrically connected to the outside terminal of the winding 30 and adapted to engage the contact R' connected to the circuit g' and later the contact R<sup>2</sup> connected to the circuit g. These contacts R' and R<sup>2</sup> can be located in any position. If the switch is open when the arm R engages the contact R', it will be automatically closed. If it is closed when the arm R engages the contact R<sup>2</sup>, it will be automatically opened. An extended contact R<sup>3</sup> may be connected to the conductor g' through a switch R<sup>4</sup> so that the switch can not be permanently closed for a considerable time, during which the arm is passing over the contact R<sup>3</sup>. The clock mechanism can be entirely cut out by the switch R<sup>5</sup>, or either part of it by one of the switches R<sup>6</sup> R<sup>7</sup>.

In the modification shown in Fig. 9, the same switch mechanism is shown connected

up so as to employ both switch arms to produce the same results in a single pole switch. In this arrangement, the switch arm 9 does not carry the load current and may be constructed of any size that will enable it to fulfil its function of controlling a local circuit by engaging the contacts 37 and 38, which are connected to the circuit so as to be in series with the local controller F when engaged by the switch arm 9. The contacts 35 and 36 are idle, and may, if desired, be omitted. The result of this is that when the switch is open, the coil 30 can be energized so as to throw the switch mechanism closed by pushing the button of the controller F, but cannot be effected by that push button after the switch is closed, since the circuit between the contact G and the source is interrupted at the contact 38. When the switch is closed, the coil 30 can be energized by pushing the button F', and when so energized, the switch will be opened. When, however, the switch is open, pushing the button F' produces no effect thereon, since the circuit between the contact G' and the source is interrupted by the disengagement of the switch arm 10 with the contacts 39. In this simple manner, the proper open circuiting of the controlling circuits is obtained with a single pole switch. In this form, one terminal of the winding 30, here shown with its two parts in multiple, is connected to the main A, and the local controlling circuits are connected to the main B. The other parts are the same as in Fig. 8, with slightly different locations, which, however, do not affect the action or result. The two parts of the solenoid winding are preferably connected together so as to be simultaneously energized, the series connection being preferred. When connected they form part of a common conducting path extending from the contacts E—E' to one of the mains A—B.

In the arrangement shown in Fig. 8, the switch arm 10 may be omitted and the switch thus reduced to a single pole switch, without interfering with its control over the local circuits.

My invention permits of various other modifications which are within its spirit and which will be evident to those skilled in the art.

With the arrangements shown, the switch mechanisms of a building may be grouped at a central point, such as a panel board, the main and controlling circuits only being led to the rooms where the translating devices are located. Various means of control located at various places may be employed, and the manually actuated controlling means can be multiplied at little trouble or expense.

What I claim is:

1. In a means for controlling electric circuits, the combination of a switch mecha-

nism having a switch arm, a pair of main circuit terminals, and a solenoid for actuating said switch mechanism to both open and close said circuit, said switch arm being electrically connected to one main circuit terminal when said circuit is both open and closed and to the other when said circuit is closed only, and a supplemental contact engaged by said switch arm when the main circuit is open only, a local circuit for said solenoid connected to one branch of the main circuit and to the supplemental contact and a local circuit controller in said local circuit.

2. In a means for controlling electric circuits, the combination of a switch mechanism having a switch arm, a pair of main circuit terminals, and a solenoid for actuating the same to both open and close said circuit, said switch arm being electrically connected to one main circuit terminal when said circuit is both open and closed and to the other when said circuit is closed only, and a supplemental contact engaged by said arm when the circuit is open only, a local circuit for said solenoid connected to one branch of the main circuit and to the supplemental contact and a local circuit controller in said local circuit, a second local circuit for said solenoid connected to one branch of the main circuit and to the other branch on the translating device side of said switch, and a local circuit controller in said second local circuit.

3. In a means for controlling electric circuits, the combination of a switch mechanism having a switch arm, a pair of main circuit terminals, and a solenoid for actuating the same to both open and close said circuit, said switch arm being electrically connected to one main circuit terminal when said circuit is both open and closed and to the other when said circuit is closed only, and a supplemental contact engaged by said arm when the circuit is open only, a local circuit for said solenoid connected to one branch of the main circuit and to the supplemental contact and a local circuit controller in said local circuit, a second local circuit for said solenoid connected to one branch of the main circuit and to the other branch on the translating device side of said switch, and a local circuit controller in said second local circuit, the solenoid winding constituting a portion of a conducting path common to both of said local circuits.

4. In means for controlling electric circuits, the combination of a double pole switch mechanism having two switch-arms,

a plurality of pairs of main-circuit contacts engaged by said switch-arms when in closed position, a solenoid for actuating said switch to both open and close the same, one switch-arm of said switch mechanism being electrically connected to one of a pair of said main circuit contacts when in both open and closed position, a supplemental contact engaged by said switch-arm when in open position, a local circuit for said solenoid having one terminal connected to one of the mains on the generator side of said switch mechanism, and the other connected to said supplemental contact, and a local circuit controller in said local circuit.

5. In means for controlling an electric circuit, the combination of a switch mechanism for controlling a main circuit, a solenoid for actuating said switch mechanism, two local circuits in relative multiple relation to each other, one connected to one branch of said main circuit on the translating device side of said switch, and the other connected to said branch through said switch mechanism when in open position, local circuit controllers in said local circuits, and means whereby said switch mechanism interrupts said last mentioned local circuit when the switch is closed, said solenoid being connected across the branches of said main circuit and in series with one of said multiple local circuits when the main circuit is opened and the other when it is closed.

6. In means for controlling an electric circuit, a switch having two switch arms mechanically connected together, quick acting means for actuating the same, and a pair of stationary contacts for each switch arm adapted to engage the opposite ends thereof, one pair of contacts being displaced relatively to its arm so as to be out of engagement therewith when the other arm is in engagement with its pair of contacts and vice versa, in combination with an actuating solenoid, two normally open local circuits for said solenoid, said normally open local circuits each having an additional break controlled by the switch so that one of said breaks is opened and the other closed by the movement thereof whenever either local circuit is closed so as to actuate said switch and normally open local circuit controllers in said local circuits respectively.

GERALD W. HART.

Witnesses:

H. A. HART,  
M. H. GLYNN.