



US00D705202S

(12) **United States Design Patent**  
**Silva**

(10) **Patent No.:** **US D705,202 S**

(45) **Date of Patent:** **\*\* \*May 20, 2014**

- (54) **ENTERTAINMENT HUB**
- (75) Inventor: **David Silva**, Neuringen (DE)
- (73) Assignee: **Hirschmann Car Communication GmbH**, Neckartenzlingen (DE)
- (\* ) Notice: This patent is subject to a terminal disclaimer.
- (\*\* ) Term: **14 Years**
- (21) Appl. No.: **29/428,991**
- (22) Filed: **Aug. 6, 2012**

- (30) **Foreign Application Priority Data**  
Feb. 7, 2012 (DE) ..... 402012100065
- (51) **LOC (10) Cl.** ..... **14-03**
- (52) **U.S. Cl.**  
USPC ..... **D14/240; D14/358**
- (58) **Field of Classification Search**  
USPC ..... D14/242, 240, 357, 358, 140-140.9, D14/155, 137, 139, 243, 348, 349, 351, 354, D14/355; 375/222; 455/557; 725/111  
See application file for complete search history.

- (56) **References Cited**  
U.S. PATENT DOCUMENTS  
D511,343 S \* 11/2005 Solomon et al. .... D14/356  
D535,281 S \* 1/2007 Yang ..... D14/203.3

D580,423 S *	11/2008	Ju	.....	D14/240
D587,267 S *	2/2009	Wang	.....	D14/356
D593,082 S *	5/2009	Jeon	.....	D14/240
D602,487 S *	10/2009	Maskatia	.....	D14/341
D623,636 S *	9/2010	Luonsinen	.....	D14/240
7,911,800 B2 *	3/2011	Smith	.....	361/752
D638,003 S *	5/2011	Chen	.....	D14/242
D641,740 S *	7/2011	Jeon et al.	.....	D14/240
D647,920 S *	11/2011	Luo	.....	D14/496
D656,936 S *	4/2012	Saunders	.....	D14/358
D661,697 S *	6/2012	Saunders	.....	D14/358

\* cited by examiner

*Primary Examiner* — Bridget L Eland  
(74) *Attorney, Agent, or Firm* — Andrew Wilford

(57) **CLAIM**  
The ornamental design for a entertainment hub, as shown and described.

**DESCRIPTION**

FIG. 1 is a top right-side back perspective view of an entertainment hub showing my new design, the left-side view being a mirror image of the right-side; FIG. 2 is another top right back perspective view thereof; FIG. 3 is a bottom right-side back perspective view thereof; FIG. 4 is a top view thereof; FIG. 5 is a bottom view thereof; and, FIG. 6 is a back elevational view thereof. The logo trademark forming part of the claimed design is a registered trademark of Hirschmann Car Communication GmbH, under 3,793,202.

**1 Claim, 3 Drawing Sheets**

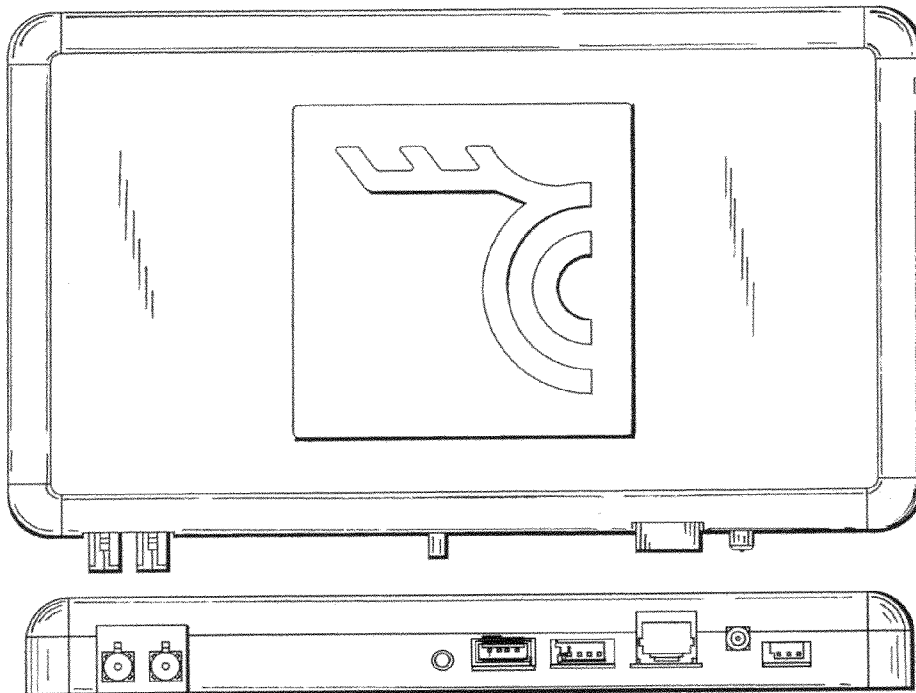

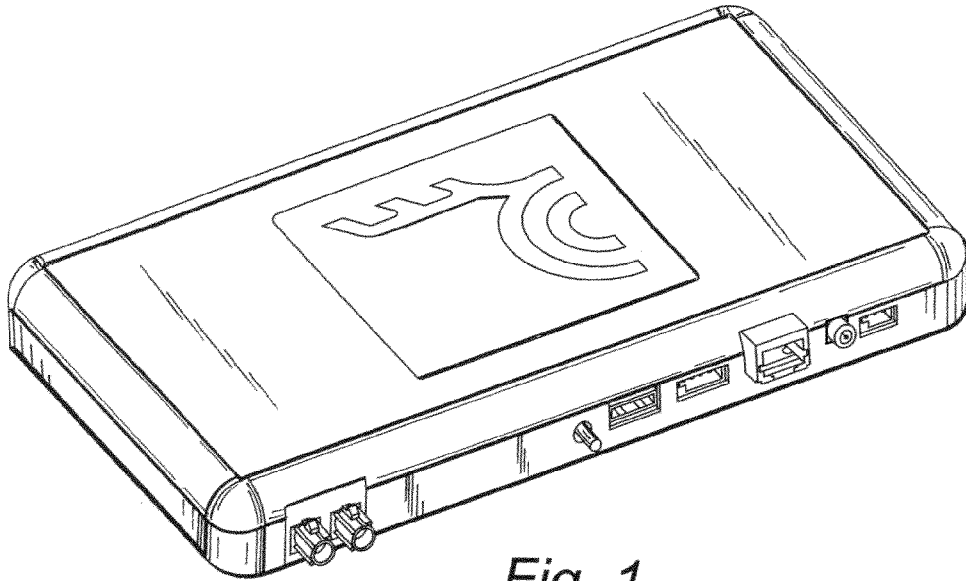

*Fig. 1*

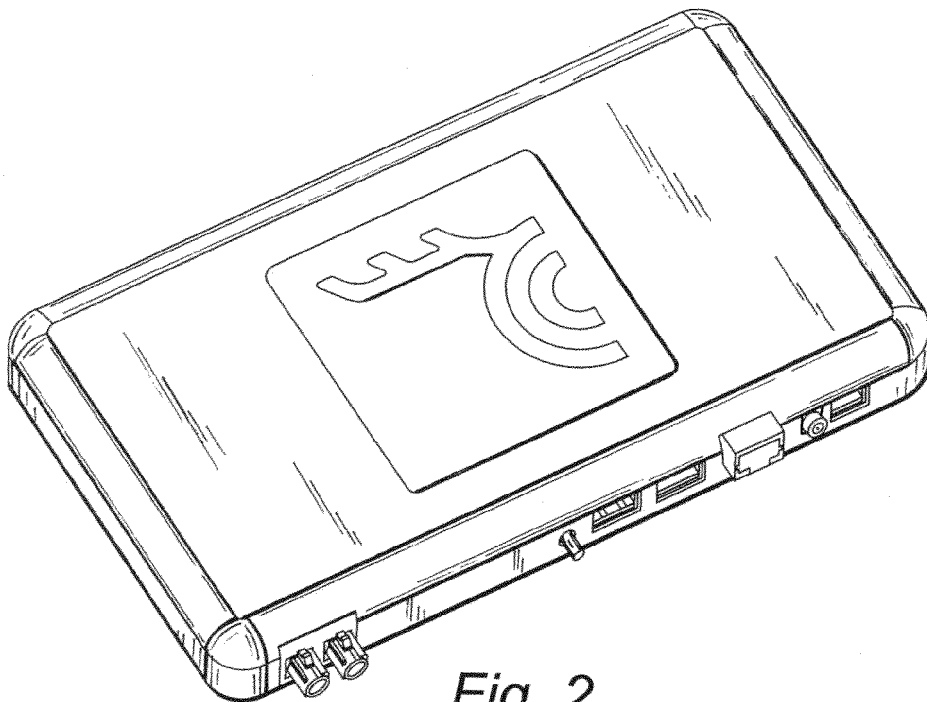

*Fig. 2*

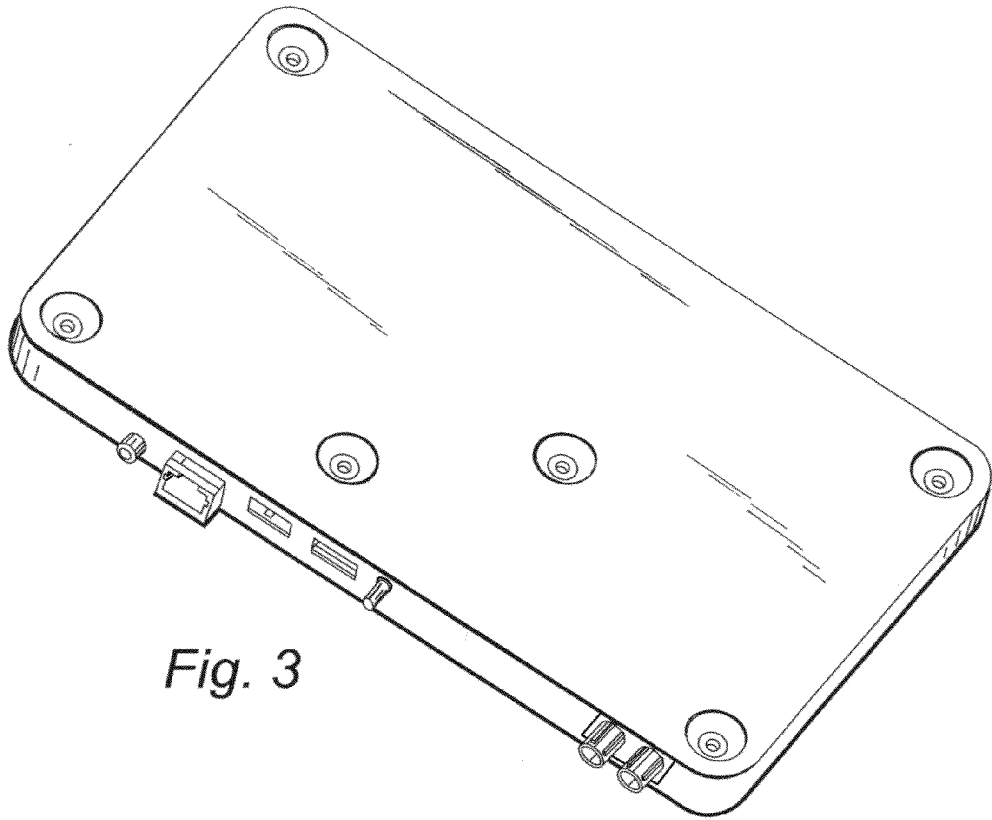

Fig. 3

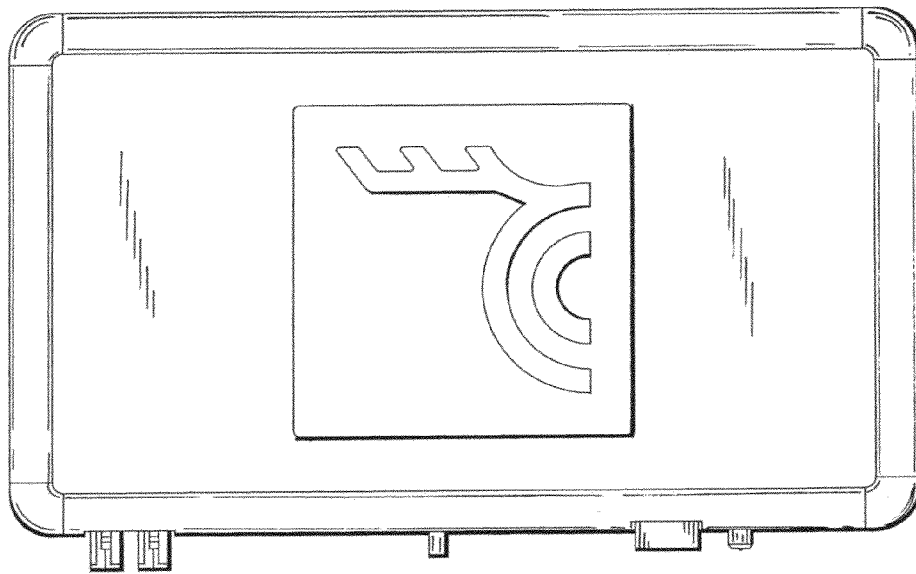
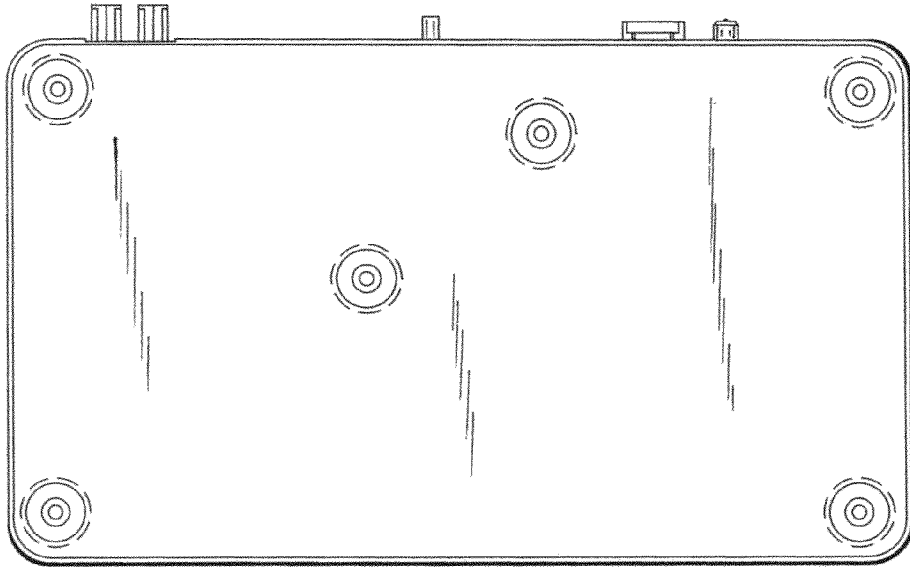
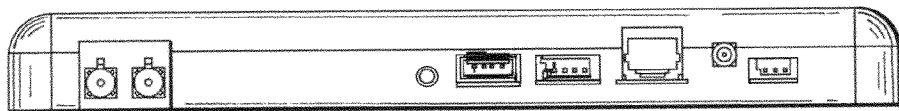

Fig. 4



*Fig. 5*



*Fig. 6*