



INTERNATIONAL APPLICATION PUBLISHED UNDER THE PATENT COOPERATION TREATY (PCT)

<p>(51) International Patent Classification ⁶ : A61N 1/365</p>	<p>A1</p>	<p>(11) International Publication Number: WO 95/19806 (43) International Publication Date: 27 July 1995 (27.07.95)</p>
<p>(21) International Application Number: PCT/EP95/00246 (22) International Filing Date: 24 January 1995 (24.01.95) (30) Priority Data: 940,035 A 24 January 1994 (24.01.94) HR (71) Applicant (for all designated States except US): PACESETTER AB [SE/SE]; S-171 95 Solna (SE). (72) Inventors; and (75) Inventors/Applicants (for US only): BOZIDAR, Ferek-Petric [HR/HR]; Sovinec 17, HR-41000 Zagreb (HR). BREYER, Branko [HR/HR]; Prilaz G. Dezelica 79, HR-41000 Zagreb (HR). (74) Agent: BLUMBACH, KRAMER & PARTNER; Radeckestrasse 43, D-81245 München (DE).</p>		<p>(81) Designated States: JP, US, European patent (AT, BE, CH, DE, DK, ES, FR, GB, GR, IE, IT, LU, MC, NL, PT, SE). Published <i>With international search report.</i> <i>Before the expiration of the time limit for amending the claims and to be republished in the event of the receipt of amendments.</i></p>
<p>(54) Title: CARDIAC ELECTROTHERAPY SYSTEM SYNCHRONIZED WITH VENOUS FLOW</p>		
<p>(57) Abstract</p> <p>A cardiac electrotherapy device comprises a catheter means (90) adapted to be inserted through a blood vessel (6) into the right ventricle of the heart, a distal pacing electrode at the distal end of said catheter means, at least one pair of Doppler measurement ultrasonic piezoelectric transducer means (91 to 94) attached to said catheter means in a position as to detect the velocity of blood flow through pulmonary veins (97) when the catheter means is inserted into the right ventricle of the heart, electrical conductors (150) arranged within said catheter means, which are connected at their distal ends to said pacing electrode and said transducer means, respectively and which are connected or connectable at their proximal ends to an electronic circuitry for receiving and processing the blood flow velocity data of the pulmonary veins (97), detected by said ultrasonic piezoelectric transducer means.</p>		

FOR THE PURPOSES OF INFORMATION ONLY

Codes used to identify States party to the PCT on the front pages of pamphlets publishing international applications under the PCT.

AT	Austria	GB	United Kingdom	MR	Mauritania
AU	Australia	GE	Georgia	MW	Malawi
BB	Barbados	GN	Guinea	NE	Niger
BE	Belgium	GR	Greece	NL	Netherlands
BF	Burkina Faso	HU	Hungary	NO	Norway
BG	Bulgaria	IE	Ireland	NZ	New Zealand
BJ	Benin	IT	Italy	PL	Poland
BR	Brazil	JP	Japan	PT	Portugal
BY	Belarus	KE	Kenya	RO	Romania
CA	Canada	KG	Kyrgyzstan	RU	Russian Federation
CF	Central African Republic	KP	Democratic People's Republic of Korea	SD	Sudan
CG	Congo	KR	Republic of Korea	SE	Sweden
CH	Switzerland	KZ	Kazakhstan	SI	Slovenia
CI	Côte d'Ivoire	LI	Liechtenstein	SK	Slovakia
CM	Cameroon	LK	Sri Lanka	SN	Senegal
CN	China	LU	Luxembourg	TD	Chad
CS	Czechoslovakia	LV	Latvia	TG	Togo
CZ	Czech Republic	MC	Monaco	TJ	Tajikistan
DE	Germany	MD	Republic of Moldova	TT	Trinidad and Tobago
DK	Denmark	MG	Madagascar	UA	Ukraine
ES	Spain	ML	Mali	US	United States of America
FI	Finland	MN	Mongolia	UZ	Uzbekistan
FR	France			VN	Viet Nam
GA	Gabon				

**CARDIAC ELECTROTHERAPY SYSTEM
SYNCHONIZED WITH VENOUS FLOW**

Field of the Invention

5

This invention relates to cardiac electrotherapy, particularly to measurement of blood flow characteristics either of the pulmonary veins or vena cava superior for the purpose of control of the cardiac electrotherapy.

10

Background of the Invention

Ultrasonic measurement of blood flow has recently become an important noninvasive diagnostic method. Two methods have emerged as practical, i.e. the continuous wave (CW) and the pulsed (PW) Doppler systems. Very sophisticated and clinically useful systems have been developed such as described in the U.S.Pat.No. 4,790,322 enabling automatic measuring independent to direction of ultrasonic beam emission. The ultrasonic transmitter-receiver for blood velocity measurement was described in the U.S.Pat.No. 4,766,905 having improved noise reduction. Another system disclosed in the U.S.Pat.No. 4,771,789 calculates and displays acceleration of moving reflective member in organism. Flow imaging detector for blood velocity measurement, such as disclosed in the U.S.Pat.No. 4,790,323, weights samples of auto-correlation function with reliability criterion so electrical noise dominated samples can be weighted less. All these inventions enabled the perfect imaging of the blood flow in the echocardiographic scanner image. Nevertheless in some clinical applications more accuracy was necessary and therefore the ultrasonic invasive methods have been introduced. An apparatus with a catheter for ultrasonic examining of hollow organs is described in the U.S.Pat.No. 3,938,502. With continuing miniaturization of the apparatus the idea of measuring blood flow or other parameters with piezoelectric transducers mounted on catheters (cardiac or other) became feasible. The localization and visualization systems have been developed which enabled the ultrasonic guidance of invasive procedures. The ultrasonic needle tip localization system was disclosed in the U.S.Pat.No. 4,249,539. The ultrasonically

15
20
25
30

marked catheters and cardiac pacing leads have been described in the U.S.Pat.No. 4,697,595 and in the U.S.Pat.No. 4,706,681, respectively.

5 A particular problem to be solved is the measurement of the blood flow characteristics of the large blood vessels. The system disclosed in the U.S.Pat.No. 4,319,580 was developed to detect air emboli in the blood by using a cylindrical transducer for the detection. This approach was adequate for strongly reflective objects such as emboli and for the specified task of essentially only detecting them. The approach, however, does not yield a possibility to measure the flow characteristics as needed for pacemaker
10 control and a development yielding such a possibility is the purpose of the present invention.

Along similar lines there have been developed devices for measurement and control of large vessel blood flow estimation and cardiac output measurement as per
15 U.S.Pat.No.4,771,788 and U.S.Pat.No.4,802,490. Apart from its use as a Doppler transducer, the device described in the U.S.Pat.No. 4,802,490 is from the ultrasonics point of view equal to the devices described in the U.S.Pats.Nos. 4,706,681 and 4,697,595 although it has an additional flow restriction device which is immaterial in the comparison of prior art for the present application. The requirement and property added
20 in the present invention is the ultrasound beam shaping and tilting means which unlike in the said inventions positively controls the direction of Doppler measurements with an added accuracy and reliability. The device described in the U.S.Pat.No. 4,771,788 has basically the same ability to measure the flow by means of ultrasound, but is not suitable for implantation in the human body as a part of an electrotherapy system. This is so
25 because it requires an additional support wire, which for different purposes may be helpful, but rules the method out for the afore mentioned purposes.

Physiologic cardiac pacing is very important on temporary as well on permanent basis. Temporary pacing is usually applied either after cardiac surgery or during myocardial
30 infarction because of the transient conduction disturbance or arrhythmia. Patients in rest have significantly improved cardiac output when ventricular contraction is synchronous

with atrial filling of ventricles. This is very important for faster recovery after surgery or myocardial infarction. Furthermore, some arrhythmias like supraventricular tachycardias and extrasystolies may be prevented by means of physiologic pacing.

5 Patients with chronic conduction and rhythm disturbance have to receive a permanent implantable pacing system. They also have a significant contribution of atria to the hemodynamic benefit. There are two basic modes of physiologic cardiac pacing: sequential and synchronous. The sequential atrio-ventricular pacing is used to restore normal atrio-ventricular relationships. In this mode an atrium and a ventricle are paced
10 by twin stimuli separated by an appropriate physiologic interval. However the heart rate is controlled by the pacemaker programme and does not vary according to the physiological needs. The synchronous cardiac pacing approximates most closely to the normal cardiac rhythm. The spontaneous atrial electrogram (P-wave) is sensed by an electrode usually in contact with the atrial endocardium and this is used to trigger the
15 ventricle after an appropriate preset delay. Because the atrial rhythm is paced by our natural pacemaker sinus-atrial node, the frequency varies naturally according to the body workload. Therefore the P-wave synchronous ventricular cardiac pacing is considered to be the most physiologic rate-responsive pacing.

20 There is a significant drawback of physiologic pacing systems which complicates the surgical procedure in comparison with non-physiologic pacing. The physiologic pacing requires the implantation of two leads: one atrial and one ventricular. Modern dual-chamber pacemakers have the ability to switch from sequential to synchronous pacing and vice versa according to the atrial rhythm which is monitored in the atrial
25 channel. If the patient has a normal function of the sinus node and atria, the atrial lead is only used to sense the atrial activity and the ventricular lead is used to sense the ventricular activity and to pace the ventricles. Because the sensing of atrial activity may be done by an electrode floating within the right atrial cavity, a lot of effort has been done to design a single pass lead for P-wave synchro- nous ventricular pacing
30 comprising the atrial and ventricular electrode on the same lead. Such a system has been described in the U.S.Pat.No. 3,903,897. However, the atrial electrogram is having

significantly lower amplitude when sensed by a floating electrode in comparison with an electrode having a direct contact with the atrial muscle. Therefore such systems have to comprise high sensitivity amplifier in the atrial channel. As a consequence, the high susceptibility on far fields appears, causing more likely occurrence of the various oversensing phenomena. Furthermore, many patients have low amplitude atrial electrogram and therefore the atrial undersensing is more frequent in such systems. The system described in the Europ.Pat.No. 311,019 monitors ventricular impedance continuously using electrode in ventricle without requiring additional sensing in the atrium. Detected impedance waveform can be used to trigger ventricular stimulus synchronously with atrial filling of ventricle.

For the purpose of identification of the different parts of cardiac cycle, the system described in the U.S.Pat.No. 4,763,646 has been developed for measurement of the heart sounds.

U.S. Pat. No. 4,600,017 discloses the pressure measurement method by means of a piezoelectric sensor fixed on the cardiac pacing lead. Our sensor assembly for blood flow measurement is very specific and not identical to a simple pressure bimorph sensor. U.S. Pat. No. 5,139,020 describes the system which monitors the systolic function of the heart. In that invention the ultrasonic beam is directed towards the left ventricle or aortic root because preferred embodiment of invention measures blood flow in aorta by means of a Doppler system. Another embodiment measures systolic time intervals in order to estimate myocardial contractility.

Synchronous pacing can be impaired by the atrial undulation and fibrillation when pacemaker sustains the maximum tracking rate during high atrial pathologic rhythm. Therefore even the intermittent atrial fibrillation is the contraindication for synchronous pacing. Patients suffering from intermittent atrial fibrillation would benefit a lot from a pacemaker comprising reliable atrial fibrillation detector and which could switch from synchronous to rate responsive pacing in the case of atrial fibrillation occurrence and

vice versa, switch back to the synchronous mode upon the fibrillation termination. It would be also important that a pacemaker could discriminate premature ventricular contractions. Especially in antitachycardia devices it would be important that a pacemaker could discriminate the sinus tachycardia from pathologic tachycardia. As far
5 it is known to the inventors, such an electrotherapy device was described only in our U.S. Patents No. 5,243,976, No. 5,316,001 and No. 5,318,595 having a tricuspid flow as a parameter for electrotherapy control. However that invention is restricted to monitor only the right heart and there is no invention, as far as it is known to the inventors, which can monitor the left heart function by means of the transducer
10 implanted within the right heart.

It is a generic object of the present invention to monitor the hemodynamic parameters of the left heart by means of a lead implanted within the right heart.

15 It is a further object of the present invention to provide a cardiac electrotherapy device (pacemaker) which will, in normal atrial rhythm, act in a synchronous mode and maintain atrio-ventricular synchronism, yet with the need for implantation of a single lead.

20 It is a further object to provide a pacemaker which comprises a sensor for rate responsive ventricular pacing and reliable means for atrial fibrillation detection, maintaining the rate responsive pacing while the atrial fibrillation is sustained. It is a special object of the present invention to provide a cardiac electrotherapy device (pacemaker) capable to detect premature ventricular contractions as well as to confirm
25 the ventricular capture.

Summary of the Invention

The invention is characterized by the features of the independent claims. Advantageous
30 embodiments of the invention are described in the subclaims.

The invention provides a pacemaker capable to discriminate the sinus tachycardia from the pathologic tachycardia and to monitor the hemodynamic parameters of the left heart by means of a lead implanted within the right heart.

- 5 In carrying out the invention, the blood flow through the right pulmonary veins is monitored with a Doppler system using piezoelectric transducers assembly mounted on a cardiac pacing lead. The flow waveform through the pulmonary veins is used for synchronization and control of ventricular cardiac pacing, as well as for the monitoring of the left ventricular systolic function. In another embodiment, the blood flow through
10 the vena cava superior is monitored, and the flow waveform is used for synchronization and control of ventricular cardiac pacing, as well as for the monitoring of the right ventricular systolic function.

Description of Preferred Embodiment

15

The invention will be more readily understood by reference to the following description and accompanying drawing in which:

20 Fig. 1 shows the heart opened at the right atrial appendage to disclose the inner right atrial anatomic structures and implanted pacing lead.

Fig. 2 shows the caudal view on the heart having a lead implanted through the superior vena cava.

25 Fig. 3 shows the heart in the same manner as in figure 1 but having a cutted vena cava superior.

Fig. 4 shows five waveforms: ECG, pulmonary veins and tricuspid flow, right atrial wall motion and phonocardiography.

30

Fig. 5 illustrates the measurement of isovolumic relaxation time from pulmonary

veins flow and phonocardiography waveforms.

Fig. 6 shows the synchronization of ventricular pacing with A-wave in pulmonary flow.

5

Fig. 7 shows the M-mode atrial contraction waveform and measurement of isovolumic relaxation time.

Fig. 8 shows the synchronization of ventricular pacing with atrial contraction wave.

10

Fig. 9 shows the theoretical background of the blood flow measurement.

Fig. 10 is the perspective view on the ultrasonic transducer assembly.

15 Fig. 11 is the cross-section of the transducer assembly.

Fig. 12 is the cross-section of the another transducer assembly.

Fig. 1 shows the heart opened at the right atrial appendage 1. There are tricuspid valve
20 2, fossa ovalis 3, coronary sinus valve 4 and crista terminalis 5 within the right atrium.
The vena cava superior 6 and the vena cava inferior 7 as well as the pulmonary artery
8 and the aorta 9 with truncus pulmonalis 10 are disclosed. The left atrium 11 with right
superior pulmonary vein 12 as well as with right inferior pulmonary vein 13 are shown.
The right ventricular apex 14 is disclosed as well as the residue of the pericardium 15.
25 The pacemaker lead 16 is implanted through the vena cava superior 6 and right atrial
cavity through the tricuspid valve 2 in the right ventricle with its tip (not shown) in the
area of apex 14. The lead 16 comprises an ultrasonic transducer assembly 17 which
produces the measurement ultrasonic field 18 directed towards the pulmonary veins 12
and 13 as well as towards the posterior right atrial wall 21 at the entry of the vena cava
30 superior.

Fig. 2 shows the caudal view on the heart having the analogous designations for same elements which are shown on previous figure. The lead 16 is implanted through the superior vena cava 6 as disclosed on this axial view. As it is clearly demonstrated in this projection, the ultrasonic measurement field 18 consists of two ultrasonic beams 19 and
5 20 produced by transducer assembly 17 and directed towards the right pulmonary veins 12 and 13 through the posterior wall 21 of the right atrium at the entry of vena cava superior.

Fig. 3 shows the same projection of the heart as in figure 1 having the analogous designations for same elements which are shown on previous figures. A transducer
10 assembly 17 is implanted more cranially, thus measuring the flow of the superior right pulmonary vein 12 by means of the two ultrasonic beams 19 and 20. The wall of the vena cava superior 21 is therefore cutted to disclose position of the transducer assembly 17.

15 As shown on the first three figures, the measurement system monitors the flow through the right pulmonary veins: either through both of them or through the one of them, depending on the position of the transducer assembly. If the transducer assembly is positioned inferiorly as disclosed in figure 1, it can measure not only the flow in right pulmonary veins or in inferior right pulmonary vein, but also the movements of the
20 posterior right atrial wall 21. Transducer assembly 17, disclosed in figures 2 and 3, may also be designed in such a way as to enable the flow measurement within the vena cava superior i.e. the transducer assembly disclosed in our U.S. Patent No. 5,243,976. The physiologic background of the entire measurement system is disclosed in next figures.

25

Fig. 4 shows five waveforms in the exact timing correlation as the physiologic events of a cardiac cycle occur. There is a sample of ECG waveform in Fig. 4A illustrating the sinus rhythm comprising P-waves followed by the QRS complexes and consequently the T-waves. A sample of venous flow waveform is disclosed in Fig. 4B comprising atrial
30 retrograde flow waves AR, systolic waves S and diastolic waves D. The pulmonary veins flow and caval flow have approximately the same waveform pattern. A sample of

tricuspid (or mitral) flow waveform is disclosed in Fig. 4C comprising early diastolic filling waves E and late atrial filling waves A. The M-mode echocardiographic waveform of the right atrial wall, which characterises the atrial wall motion in direction of ultrasonic transducer directivity axis, is disclosed in Fig. 4D comprising the atrial contraction waves AC as well as the ventricular contraction waves VC. Phonocardiographic waveform is disclosed in Fig. 4E comprising first heart sounds designated by I as well as second heart sounds designated by II. There may be some mutual timing shifts among disclosed waveforms due to the interatrial conduction time.

10 A heartbeat is initiated by an atrial electric depolarization which is represented by a P-wave 30 in the ECG waveform. Consequently the atrial contraction occurs which is exemplified by an atrial contraction wave 31 on the right atrial wall M-mode echocardiographic waveform. This contraction generates the reversal of flow 32 through the pulmonary and caval veins as well as the late diastolic filling 33 of ventricles. At the cessation of flow through the mitral and tricuspid valve as well through the veins, the atrial diastole is characterized by the mitral and tricuspid valves closure which is heard as a first heart sound 34. At that time the ventricular depolarisation, represented by a QRS complex 35, has been completed causing the consecutive ventricular contraction. During ventricular systole, the atrial pressure decreases because of the atrial relaxation 20 36 as well as because of displacement of the mitral and tricuspid annulus in a rightward direction toward the apex which causes an increase 37 in atrial size. Both these factors provide the systolic venous flow wave 38 which is disclosed for example to be a monophasic wave. It can also have the biphasic appearance comprising two peaks clearly disclosing both factors: atrial and ventricular. The T-wave 39 corresponds to the ventricular repolarization causing the ventricular relaxation which closes the aortic and pulmonary valves which is heard as a second heart sound 40. Consequently mitral as well as tricuspid valves open and the rapid early diastolic filling 41 of ventricles occurs. This is exhibited also by diastolic venous flow wave 42 as well as by a decrease of atrial size 43.

30

Fig. 5 illustrates the measurement of left ventricular isovolumic relaxation time (IVRT)

from pulmonary venous flow comprising systolic wave S, diastolic wave D and atrial wave A as well as phonocardiography waveform comprising first heart sound MT and second heart sound AP. Just for example, systolic flow wave is disclosed to be biphasic in order to demonstrate a dissociation between atrial relaxation and mitral annular displacement. The isovolumic relaxation time is a period in the cardiac cycle between the aortic valve closure and the onset of the mitral flow. It can be used as a sensor for rate variation in rate responsive pacing. During the physical exercise, the IVRT decreases. Therefore an algorithm may be used within the control circuits of an electrotherapy device, to increase the pacing rate as the IVRT decreases. The aortic valve closure as well as the pulmonary valve closure generate the second heart sound AP. The peak of diastolic wave D in pulmonary venous flow waveform occurs after the peak of the left ventricular rapid filling wave. During ventricular diastole, left atrial pressure decreases allowing the pulmonary veins to fill the left atrium. During this phase, the left atrium is an open conduit between the pulmonary veins and the left ventricle, thus causing a close relationship between pulmonary venous diastolic flow and left ventricular inflow. Therefore the onset of pulmonary venous diastolic flow coincides approximately with termination of isovolumic relaxation. The measurement of the time interval between the second heart sound 44 and the imaginary point of diastolic wave onset 45 provides the information about the isovolumic relaxation duration of the left ventricle. This interval is not exactly equal to the IVRT, but relative variation of this interval is equivalent to the variation of IVRT, this variations being the consequence of the fluctuation of circulatory catecholamines concentration as well of the autonomous regulation of the heart. There is no influence of the atrial reversal flow on this measurement and therefore the IVRT measured from pulmonary venous flow can be used as a rate responsive sensor in sinus rhythm as well as in atrial fibrillation when atrial flow wave disappears.

Fig. 6 illustrates how the ventricular pacing can be synchronized with atrial reversal flow wave in order to obtain single lead VDD pacing. After the P-wave 50, the atrial contraction generates the atrial retrograde flow wave 51 through caval veins as well as through pulmonary veins. If the electrotherapy device comprises some means for the

onset of the wave 51 detection, it is possible to initiate the atrio-ventricular delay interval 52. At the end of the AV delay 52, the ventricular pacing spike 53 is released producing the ventricular depolarisation response 54.

- 5 Such an electrotherapy device can easily differentiate the sinus rhythm from atrial fibrillation. Disappearance of A-wave together with systolic wave amplitude decrease means that the atrial fibrillation occurred. In that case the automatic switching from A-wave synchronized ventricular pacing to rate responsive ventricular pacing can be obtained. The AV delay 52 is much shorter in comparison with the AV delay in P-wave
- 10 synchronized ventricular pacing in dual chamber pacemakers when endocardial atrial potential is detected. Therefore the shortest possible AV delay in disclosed system is the one obtained when the ventricular spike is generated synchronously with the onset of the A-wave.
- 15 Specific patterns of venous flow waveform occur in different kinds of arrhythmias. For example, significant decrease of the peak diastolic as well as systolic velocity occur in ventricular tachycardia. Confirmation of capture in ventricular pacing is possible because in the case of the loss of capture diastolic wave disappears as well as peak systolic velocity decreases. Estimation of atrial pressure is possible by means of the
- 20 measurement of peak atrial reversal velocity.

Fig. 7 illustrates how to measure the isovolumic relaxation time from the atrial wall contraction M-mode ultrasonic waveform and the phonocardiographic waveform. In atrial undulation and fibrillation, the fibrillatory waves 70 can be detected. Ventricular

25 contraction 71 and ventricular relaxation 72 yield a significant displacement of the atrial wall. Approximately at the point 73 of the zero of the first derivative of the waveform, the mitral flow is initiated. Therefore the time interval between the second heart sound 74 and the point 73 is the isovolumic relaxation time IVRT.

- 30 Fig. 8 illustrates how the atrial synchronous ventricular pacing may be obtained from the atrial wall contraction waveform. Detected atrial contraction wave 80 initiates the

atrio-ventricular delay and provides the ventricular pacing spike 81 at the end of the AV delay. Captured pacing spike exhibit the ventricular response 82 and consequently the ventricular contraction 83.

5 Fig. 9 describes the theoretical background of the principle of ultrasonic measurement in our system. The transducer array consisting, in the illustrated implementation, of piezoelectric transducers 91, 92, 93 and 94 can, by appropriate choice of activation of the transducers, generate the two needed ultrasound beams. The said beams are
10 illustrated in this Fig. with their polar directivity diagrams 95 and 96. The directivity axes can be put to different angular differences X by the use of phase differences in activation of the said transducers as well as by the sequential use of different transducers. The known azimuthal angle difference X makes it possible to correctly calculate the blood flow velocity independently of the actual angles between the said ultrasound beams and the flow direction. In order to measure the velocity, the Doppler
15 shifts for both beams must be measured independently. The ratio of the said Doppler shifts combined with the geometrical complementarity of the said angles $Z1$ and $Z2$ yield an unambiguous analytical equation with only one physical solution for calculation of the velocity by taking only the said measured Doppler shifts and the steerable and known angle X between the beams. The arrangement is self compensating for moderate
20 torsional movements of the catheter body 90 in the azimuthal plane. The limitation of this torsional movement is the approach of any of the angles $Z1$ or $Z2$ to 90° , i.e. the angle must be below approximately 85° and 95° respectively. An approach to the said limiting angles can automatically be detected by means of measurement of the variance of three subsequent measurements in a sequence two orders of magnitude faster than the
25 heart beat frequency or by the measurement of the ratio of the two velocity measurements using beams 95 and 96 which asymptotically tends to infinity and can electronically be detected. While the mathematical analysis holds for implementations as pulsed as well as continuous wave Doppler systems, the preferred embodiment is pulsed Doppler technology known in the art to be less sensitive to possible flows and movement
30 of targets behind and in front of the analysed blood vessel 97. The electronic circuits which serve the measurement assembly in Fig. 9 have the ability to measure the Doppler

shift as known in the art and additional processing circuits to measure the said variance of the said successive Doppler shift measurements and the said ratio of the two measurements as well as electronic circuits or software which takes action upon detection of such a state.

5

In the embodiment of Fig. 10, the perspective view on the pacing lead segment is disclosed, whereon the transducer assembly for blood flow measurement is mounted fixed on the temporary pacing bipolar lead body 100. Within the cavity of the lead body 100 there are two lead wires 101 and 102 for transmission of the pacing and sensing signals. On their distal end (not shown), the lead wires 101 and 102 are electrically connected to the electrodes of the lead. On their proximal end (not shown), the lead wires 101 and 102 are electrically connected to corresponding pins of the lead connector (not shown) enabling connection with the electronic circuits of the ultrasonically controlled pacemaker (not shown). Transducer assembly consists of the four transducer fragments 103, 104, 105 and 106, each having the corresponding lead wire 107, 108, 109 and 110 respectively. For the purpose of explanation, there is no insulating covering layer over the transducer assembly. Disclosed transducer fragments are, for example and for purpose of distinction, shown to be fixed on the surface of the lead body. In the embodiment of Fig. 11, there is disclosed a possible cross-section of the transducer array assembly using piezoelectric platelets embedded within the lead body 120. Platelet 121 has two metalized layers 125 and 126 which are actually the transducer electrodes. Accordingly, platelet 122 comprises electrodes 127 and 128, platelet 123 the electrodes 129 and 130, and platelet 124 the electrodes 131 and 132. Transducer electrodes 125, 127, 129 and 131 are connected by means of soldering joints 140, 142, 144 and 146 respectively and by means of a soldering joint 148 to the common lead wire 149. Lead wire 149 is also used for transmission of cardiac pacing and sensing signal together with the lead wire 150. Transducer electrode 126 is electrically connected to the lead wire 134 by means of the soldering joint 133. Transducer electrode 128 is electrically connected to the lead wire 135 by means of the soldering joint 164. Transducer electrode 130 is electrically connected to the lead wire 137 by means of the soldering joint 136. Transducer electrode 132 is electrically connected to the lead wire 139 by

10
15
20
25
30

means of the soldering joint 138. In disclosed electrical connection, transducer platelets are energized through the lead wire 149 and lead wires 134, 135, 137 and 139. In this illustrative example transducer platelets are covered by an insulation membrane 151.

5 In the embodiment of Fig. 12 there is disclosed the same cross-section as in previous Fig.. The transducer assembly consists of an array of the four piezoelectric segments 152, 153, 154 and 155 which have been obtained by means of a cutting of the tubiform transducer. The electrical connection is analogous to the one disclosed in Fig. 11 and therefore electrical wires and joints are not designated. In both examples of Fig. 11 and
10 12, the transducer assembly is fixed to be embedded within the hollow plastic lead body 120. It is technologically also possible to fix the transducer segments on the surface of the lead body which example is not shown.

As an illustrative example, disclosed assembly from previous three Figures consists of
15 four transducer segments, being a redundant design. Such a design enables the surgeon to approximately position the lead in order to achieve the approximate posterior ultrasound beam directivity. Precise directivity is obtained by means of the selection of the appropriate contiguous pair of transducer segments. This operational principle is important for temporary cardiac pacing when fast lead implantation and instant function
20 of the system is desirable. However, system can function having two transducer segments, but such a design is more sensitive on the radial orientation. Such a design, having simpler connections, would be more appropriate for permanent cardiac pacing system.

25 Measurement of caval venous flow is more simple because of the fact that flow measurement transducer is within blood flow itself. Therefore other simple flow measurement methods may be used. If ultrasound is used, we recommend the transducer assembly such as disclosed in our U.S. Patent No. 5,243,976. While specific embodiment of the present invention has been described, it should be understood that
30 this embodiment is described for purpose of illustration only. The foregoing description is not intended in any way to limit the scope of the present invention. Rather is the

intention that the scope of the invention be limited only as defined in the appended claims.

Claims

1. A cardiac electrotherapy device comprising
a catheter means (16, 90, 100, 120) adapted to be inserted through a blood
5 vessel (6) into the right ventricle of the heart,
a distal pacing electrode at the distal end of said catheter means,
at least one pair of Doppler measurement ultrasonic piezoelectric transducer
means (17, 91 to 94, 103 to 106, 121 to 124, 152 to 155) attached to said catheter
means in a position as to detect the velocity of blood flow through pulmonary veins (12,
10 13) when the catheter means is inserted into the right ventricle of the heart,
electrical conductors (150) arranged within said catheter means, which are
connected at their distal ends to said pacing electrode and said transducer means,
respectively and which are connected or connectable at their proximal ends to an
electronic circuitry for receiving and processing the blood flow velocity data of the
15 pulmonary veins, detected by said ultrasonic piezoelectric transducer means.
2. A cardiac electrotherapy device comprising a blood flow velocity
measurement cardiac pacing lead, electronic circuitry for cardiac electrotherapy and
electronic circuitry for blood flow velocity measurement, timing and processing of the
20 velocity data, said system comprising means for a ventricular pacing synchronous with
atrial contractions with the use of a single said lead and means for a rate responsive
pacing, wherein said
means are controlled by means of processing of the blood flow waveform
through pulmonary veins.
25
3. The cardiac electrotherapy device according to claim 1 or 2 wherein said
means are controlled by means of processing of the blood flow waveform through
superior vena cava.
- 30 4. The cardiac electrotherapy device according to any of claims 1 to 3,
comprising means for measurement of the blood flow velocity during determined time

interval synchronized with the ventricular electrical activity, said interval occurring with determined delay after ventricular activity.

5 5. The cardiac electrotherapy device according to any of claims 1 to 4, comprising means for discrimination between reversal flow wave (32, 51) caused by the atrial contraction, systolic flow wave (38) caused by the ventricular contraction and diastolic flow wave (42) caused by the ventricular relaxation, as well as means for measurement of peak velocities (AR, S, D) of all three said waves and calculation of time integrals of all three said waves.

10

6. The cardiac electrotherapy device according to claim 5, comprising means for ventricular pacing (53) synchronous with reversal flow wave (51) detected by said circuitry, whereby ventricular pacing maintains the physiologic atrio-ventricular delay (52).

15

7. The cardiac electrotherapy device according to claims 1 to 6, comprising means for detection of atrial fibrillation i.e. the disappearance of said reversal flow wave (32, 51) as well as means to maintain the rate responsive ventricular pacing while the atrial fibrillation is sustained, and means to revert to synchronous ventricular pacing upon the occurrence of said reversal flow wave.

20

8. The cardiac electrotherapy device according to claims 1 to 6, comprising means for atrial pressure measurement based upon the calculations of mutual relations of said peak velocities and said time integrals of the said three flow velocity waves.

25

9. The cardiac electrotherapy device according to claims 1 to 6, comprising means for ventricular and supraventricular arrhythmias detection based upon the calculations of mutual relations of said peak velocities and said time integrals of the said three flow velocity waves.

30

10. The cardiac electrotherapy device according to claims 1 to 6, comprising

means for calculation of stroke volume variation based upon the measurement of said integral variation of said systolic wave.

11. The cardiac electrotherapy device according to claim 7, comprising
5 means for measurement of the first derivative of the said systolic wave, said derivative being the sensor for rate responsive pacing in such a way as that the pacing rate increases whenever the said derivative increases and vice versa.

12. The cardiac electrotherapy device according to claim 7, comprising
10 means for measurement of the first derivative of the said diastolic wave, said derivative being the sensor for rate responsive pacing in such a way as that the pacing rate increases whenever the said derivative increases and vice versa.

13. The cardiac electrotherapy device according to any of claims 5 to 9,
15 comprising means for detection of missing ventricular contraction i.e. the disappearance of said systolic wave (38), and means to discriminate if missing contractions are caused by the loss of capture or by the ventricular fibrillation or tachycardia.

14. The cardiac electrotherapy device according to claim 10, comprising
20 means for detection of sudden stroke volume decrease in single beat, said sudden decrease indicating that said single beat is the ventricular premature beat.

15. The cardiac electrotherapy device according to claim 10, comprising
25 means for detection of sudden stroke volume decrease in series of beats, said sudden decrease indicating that said series of beats is the ventricular tachycardia.

16. The cardiac electrotherapy device according to any of claims 1 to 15
comprising a Doppler measurement cardiac pacing lead and electronic circuitry for
Doppler blood flow velocity measurement wherein said Doppler measurement cardiac
30 pacing lead comprises

a plastic catheter body (16, 90, 100, 120), lead conductors

(101/102/107/108/109/110, 149/150/134/135/137/139/141/143/145/147) and a pacing electrode, at least one pair of Doppler measurement ultrasonic piezoelectric transducer means (17, 91 to 94, 103 to 106, 121 to 124, 152 to 155), comprising transducer electrodes (125 to 132), said pair of transducer means being arranged and mounted onto
5 the said cardiac lead at the circumference thereof in a manner as to be able of generating two ultrasonic beams (95, 96) for independent measurement of Doppler shifts for both said beams.

17. The cardiac electrotherapy device according to claim 16, wherein
10 directivity axes of said two beams are put in an azimuthal angle difference (X) in such a way as to enable calculation of blood flow velocity independently of the actual angles between the said ultrasonic beams and the said blood flow direction.

18. The cardiac electrotherapy device according to claim 16 or 17, wherein
15 said piezoelectric transducers means (17, 91 to 94, 103 to 106, 121 to 124) have a shape of platelets, mounted at the circumference of said cardiac lead and poled by means of said transducer electrodes (125 to 132) so as to generate radial directivity characteristic in one azimuthal plane.

19. The cardiac electrotherapy device according to claim 16 or 17, wherein
20 said piezoelectric transducers means (17, 152 to 155) have a shape of tube segments, mounted at the circumference of said cardiac lead and poled by means of said transducer electrodes (125 to 132) so as to generate radial directivity characteristic in one azimuthal plane.

20. The cardiac electrotherapy device according to any of claims 16 to 19
25 wherein internal array of said transducer electrodes (125,127,129,131) is electrically connected to one of said lead conductors (149) by means of joints (148,140,142,144,146) and auxilliary lead conductors (141,143,145,147), while external
30 array of said transducer electrodes (126,128,130,132) is electrically connected to separate set of said lead conductors (134,135,137,139) by means of joints

(133,164,136,138) so as to obtain the same polarity of all transducers as well as to enable the sequential switching of said transducers in such a way as to not impede the pacing and sensing function of said cardiac electrotherapy device.

5

1/10

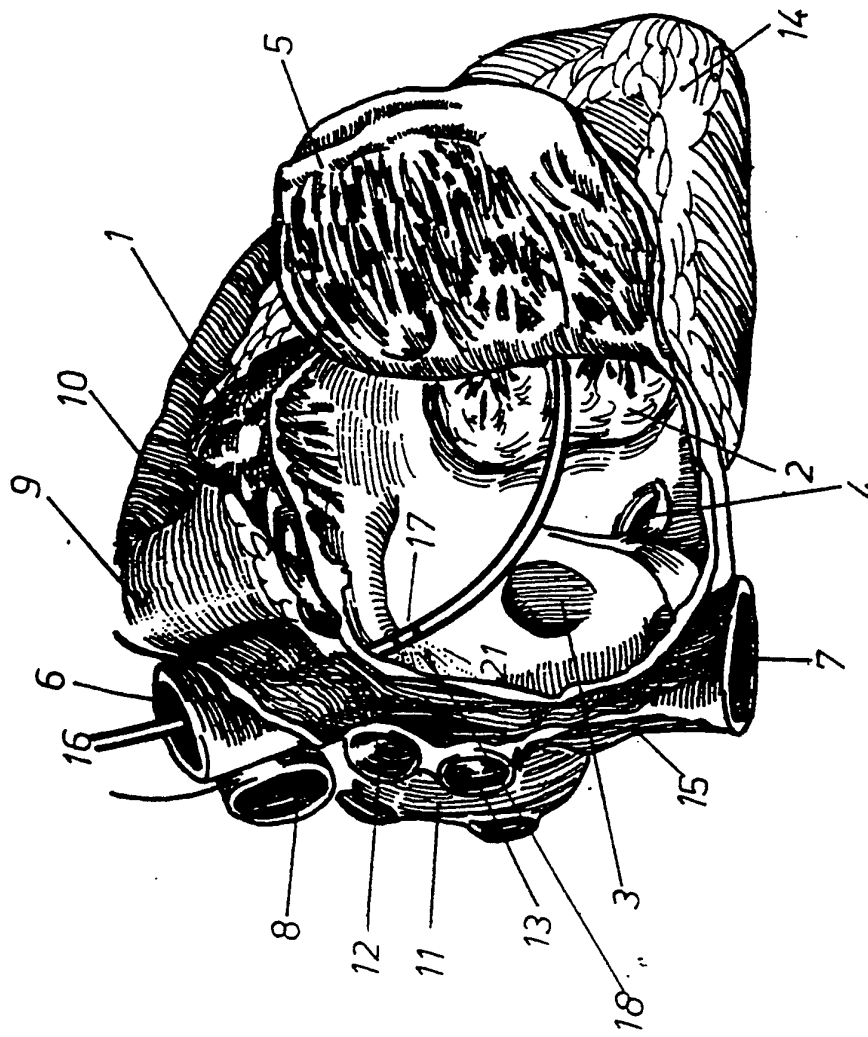

FIGURE 1

2/10

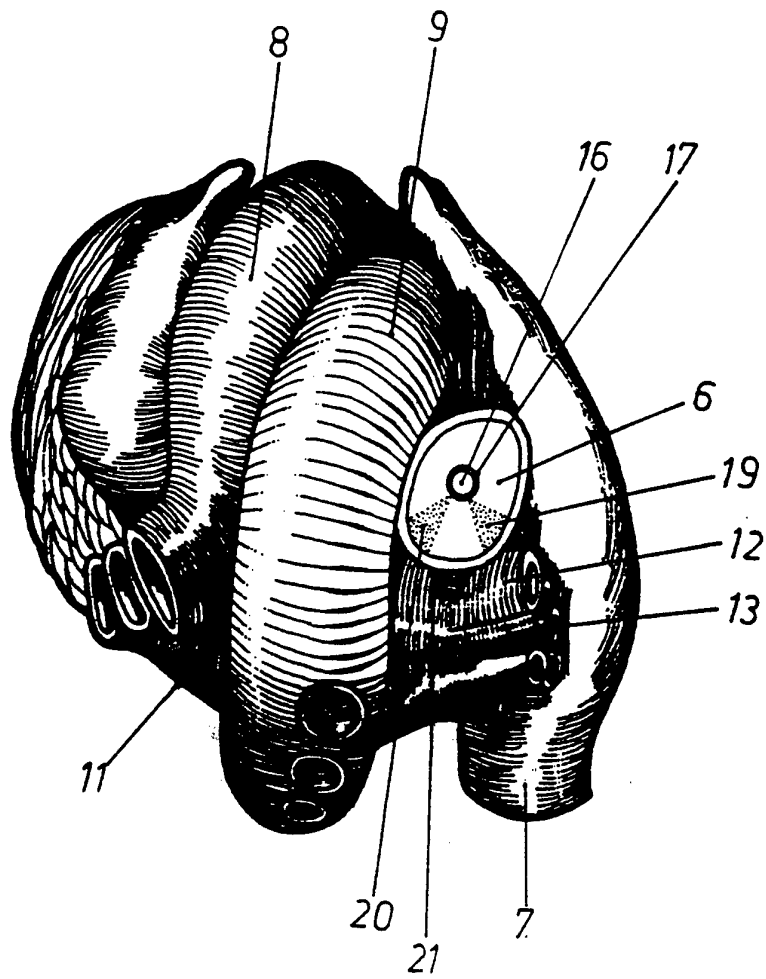

FIGURE 2

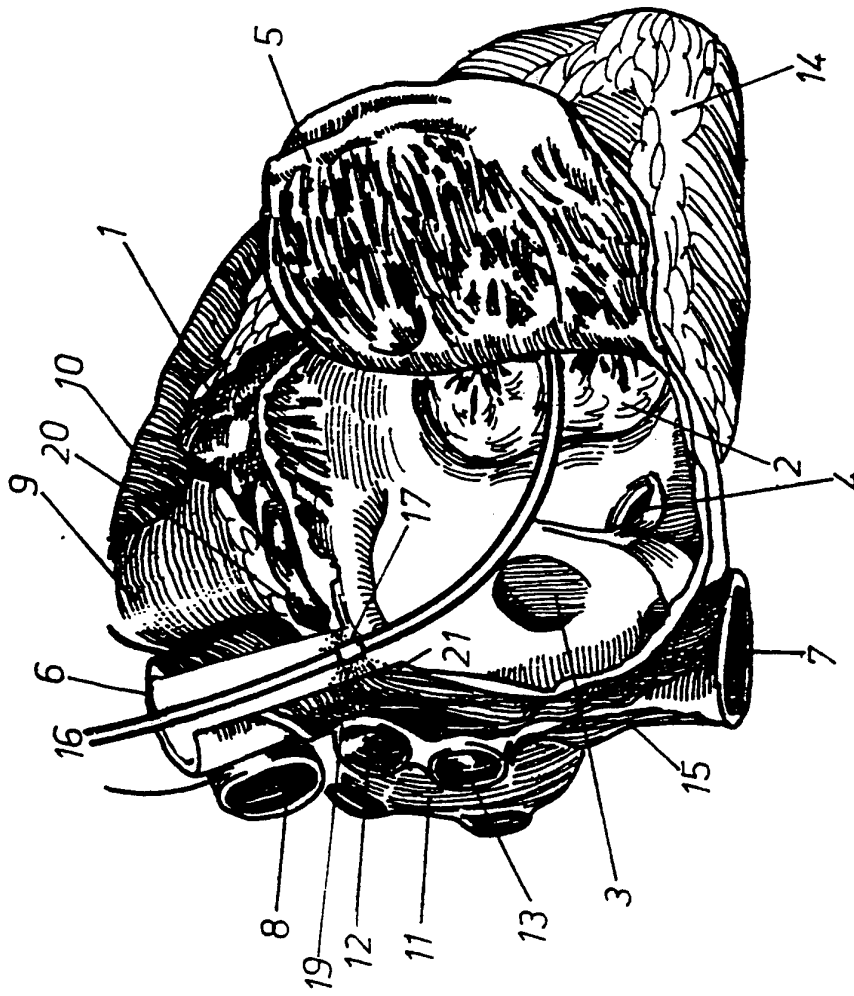

FIGURE 3

4 / 1 0

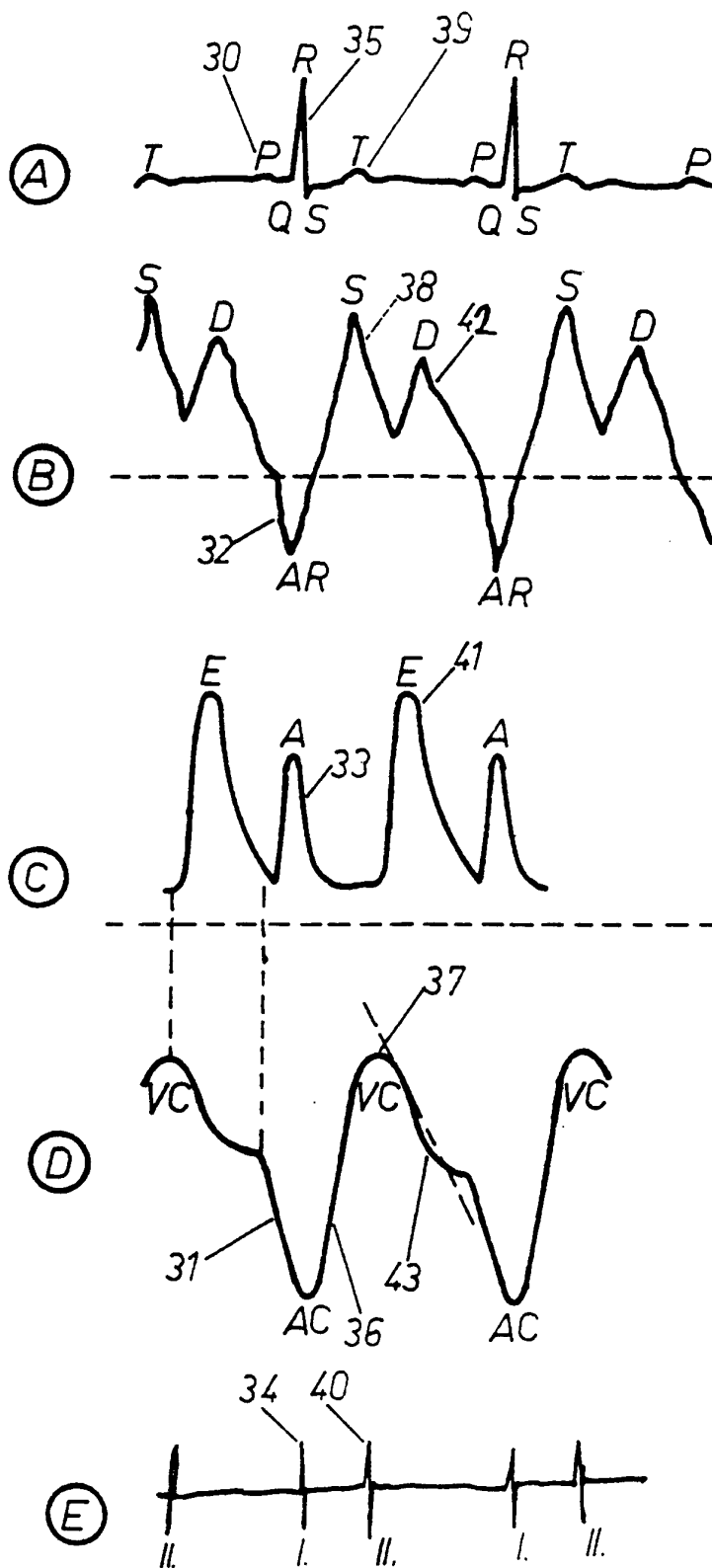

FIGURE 4

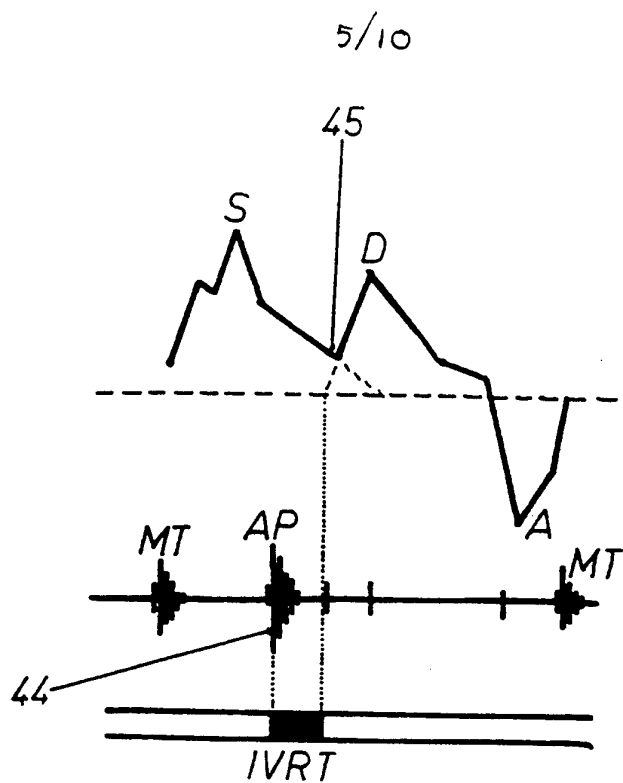

FIGURE 5

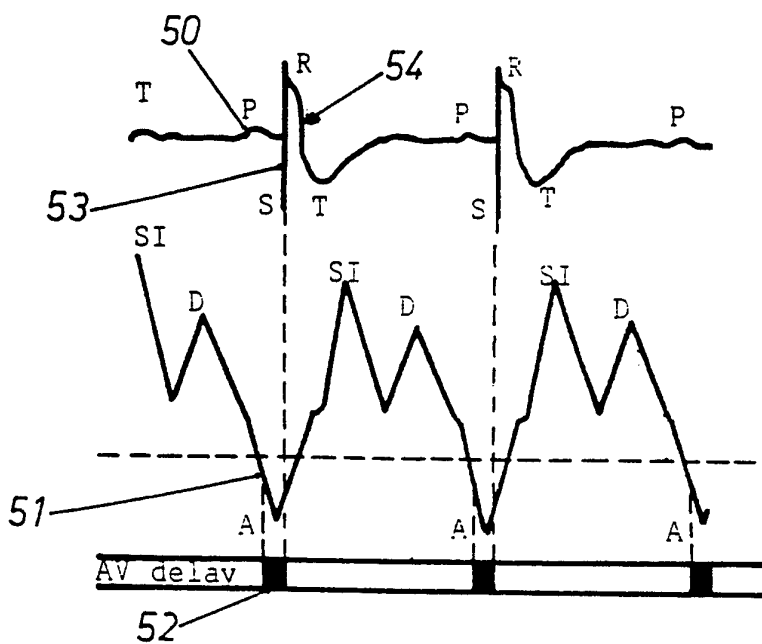

FIGURE 6

6 / 1 0

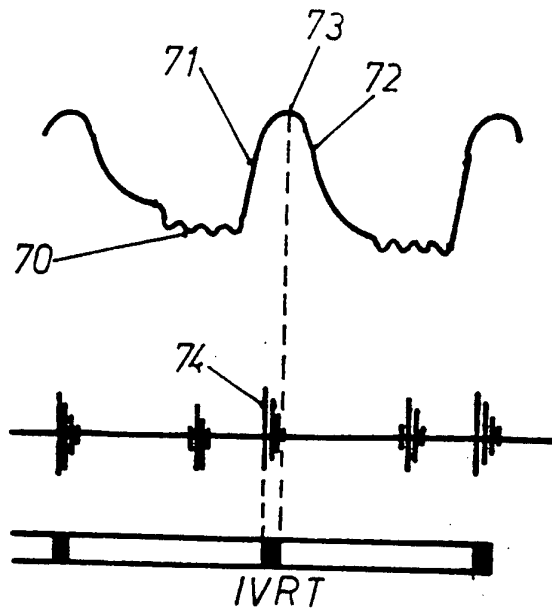

FIGURE 7

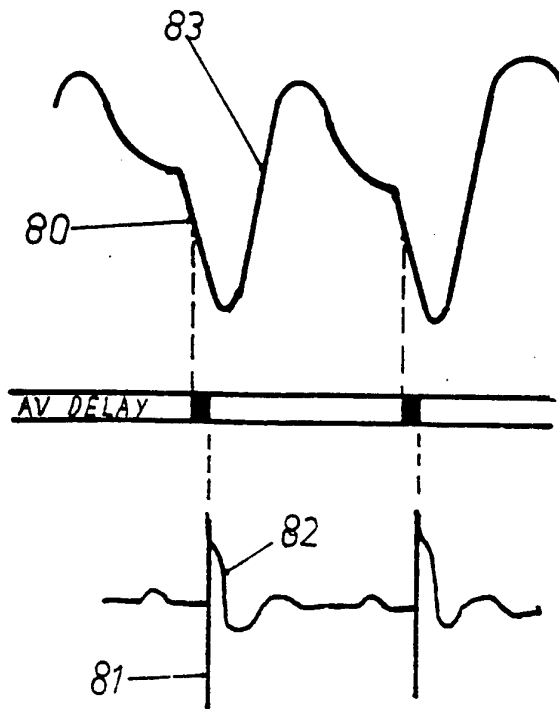

FIGURE 8

7/10

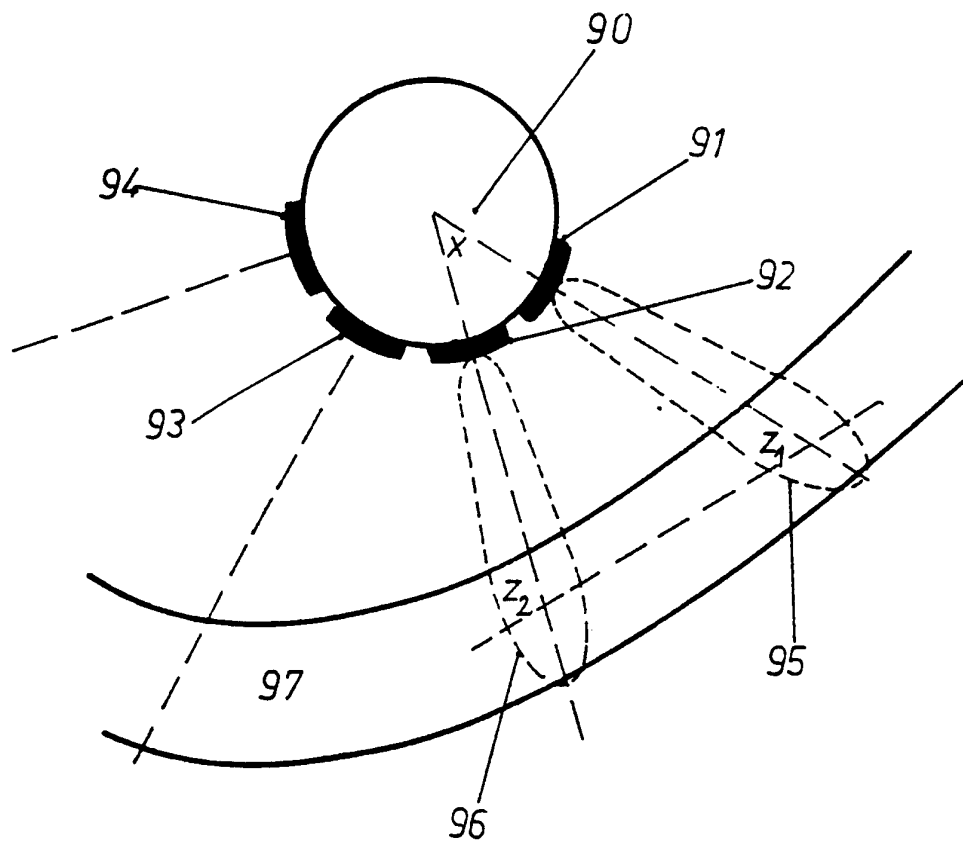

FIGURE 9

8/10

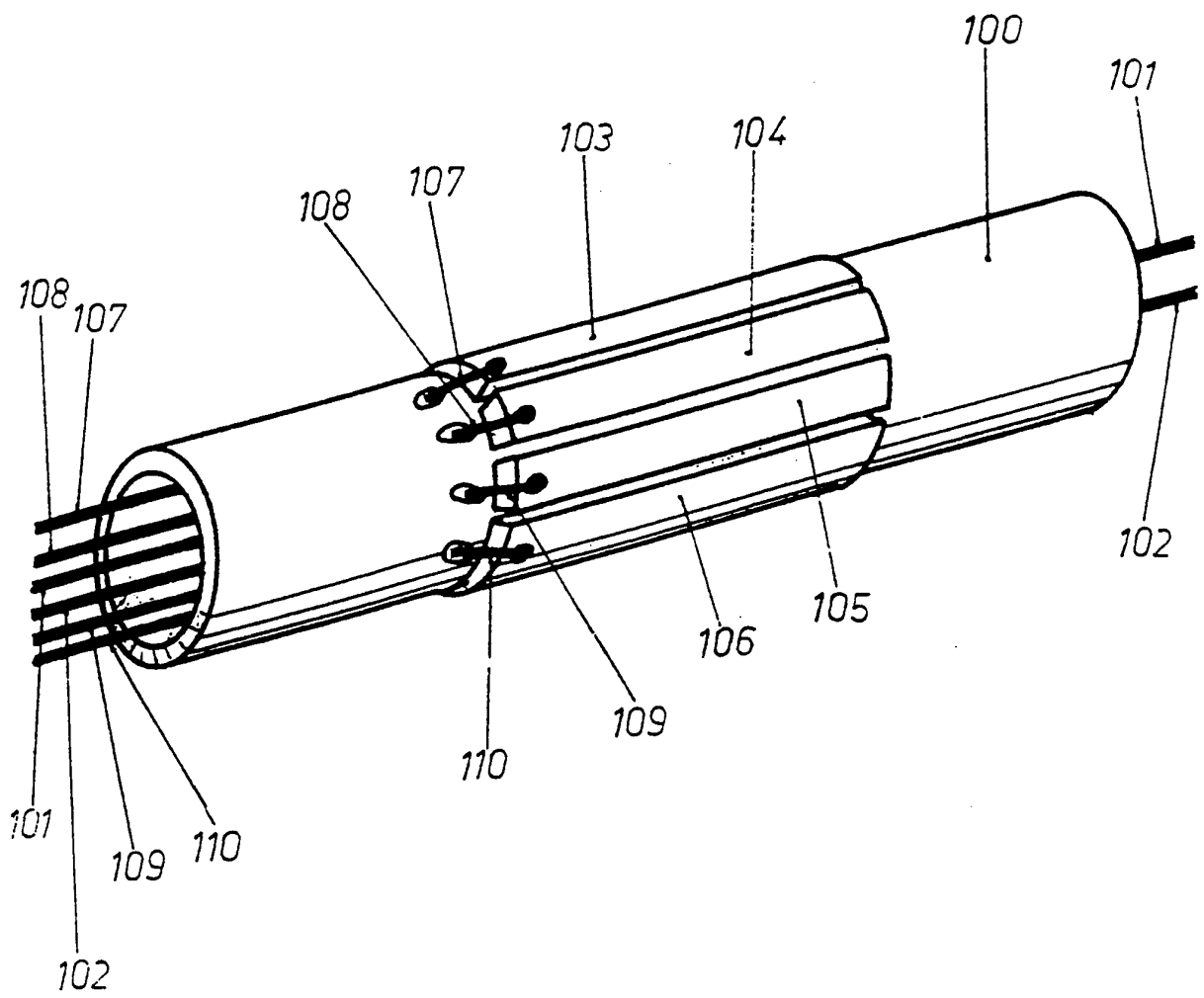

FIGURE 10

g/10

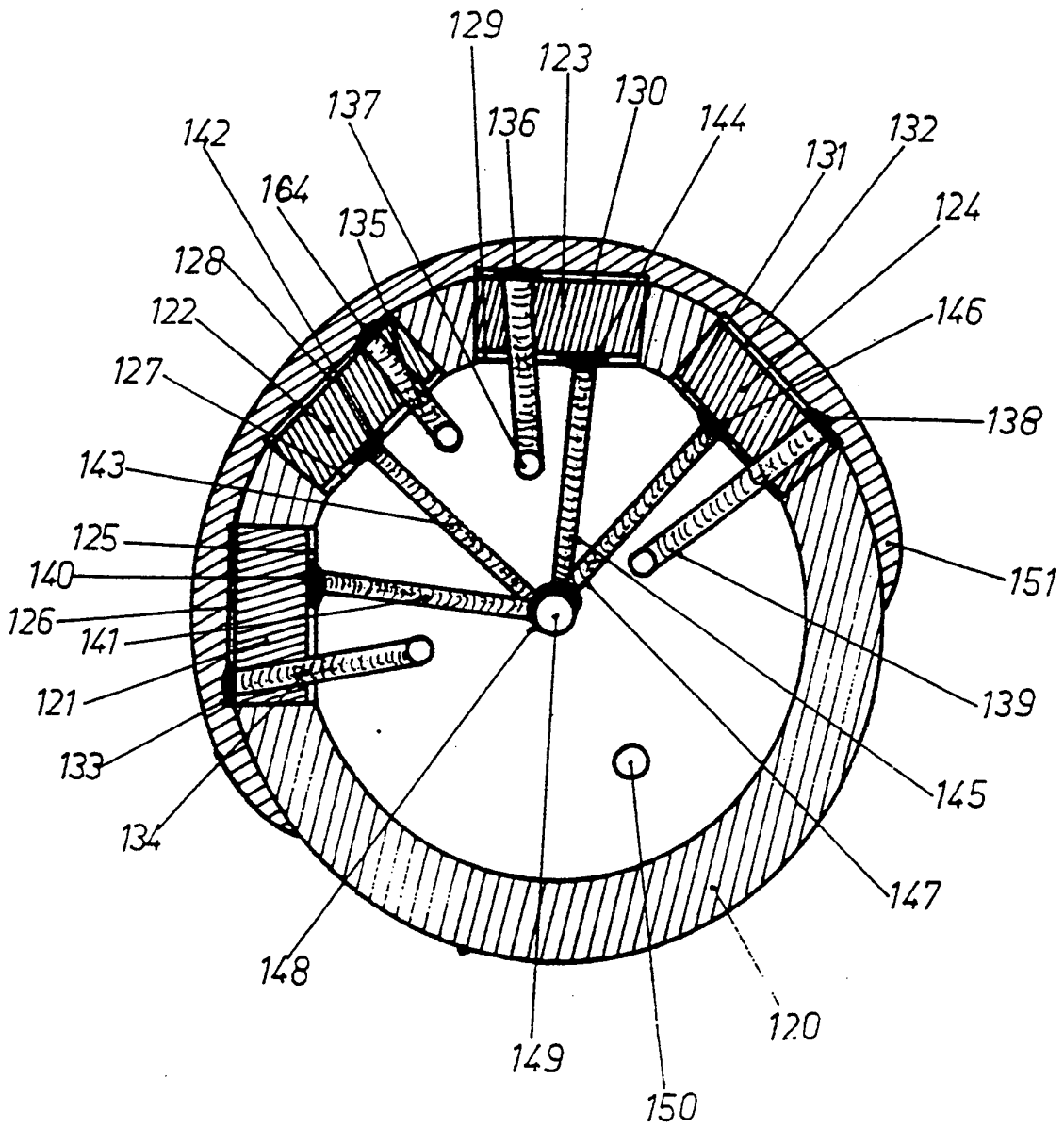

FIGURE 11

16 / 10

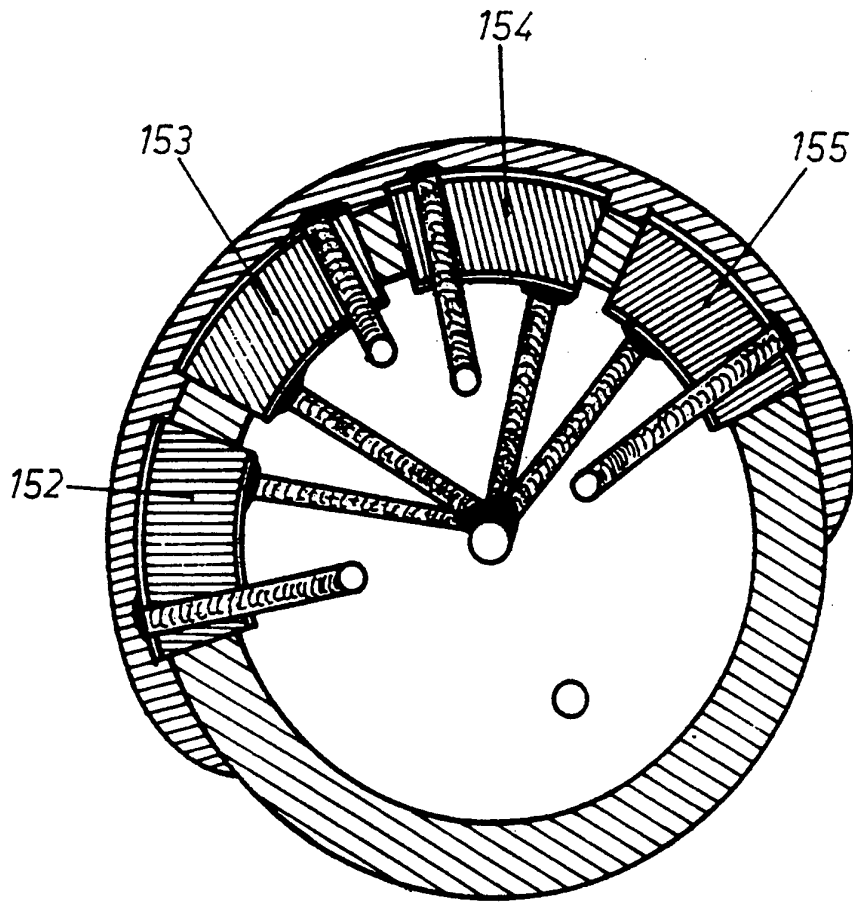

FIGURE 12

INTERNATIONAL SEARCH REPORT

International Application No
PCT/EP 95/00246

A. CLASSIFICATION OF SUBJECT MATTER
IPC 6 A61N1/365

According to International Patent Classification (IPC) or to both national classification and IPC

B. FIELDS SEARCHED

Minimum documentation searched (classification system followed by classification symbols)
IPC 6 A61N

Documentation searched other than minimum documentation to the extent that such documents are included in the fields searched

Electronic data base consulted during the international search (name of data base and, where practical, search terms used)

C. DOCUMENTS CONSIDERED TO BE RELEVANT

Category *	Citation of document, with indication, where appropriate, of the relevant passages	Relevant to claim No.
A	EP,A,0 474 957 (BOZIDAR) 18 March 1992 cited in the application see page 4, column 6, line 12 - page 10, column 18, line 23; figures see claims ---	1-7, 11-20
A	US,A,5 183 040 (NAPPOLZ) 2 February 1993 see column 8, line 23 - column 20, line 55; figures ---	1-7,9, 13,16,19
A	US,A,4 802 490 (JOHNSTON) 7 February 1989 cited in the application see column 3, line 58 - column 7, line 6; figures ---	1-4, 16-20
	-/--	

Further documents are listed in the continuation of box C. Patent family members are listed in annex.

* Special categories of cited documents :

"A" document defining the general state of the art which is not considered to be of particular relevance

"E" earlier document but published on or after the international filing date

"L" document which may throw doubts on priority claim(s) or which is cited to establish the publication date of another citation or other special reason (as specified)

"O" document referring to an oral disclosure, use, exhibition or other means

"P" document published prior to the international filing date but later than the priority date claimed

"T" later document published after the international filing date or priority date and not in conflict with the application but cited to understand the principle or theory underlying the invention

"X" document of particular relevance; the claimed invention cannot be considered novel or cannot be considered to involve an inventive step when the document is taken alone

"Y" document of particular relevance; the claimed invention cannot be considered to involve an inventive step when the document is combined with one or more other such documents, such combination being obvious to a person skilled in the art.

"&" document member of the same patent family

Date of the actual completion of the international search 31 May 1995	Date of mailing of the international search report 16.06.95
--	--

Name and mailing address of the ISA European Patent Office, P.B. 5818 Patentlaan 2 NL - 2280 HV Rijswijk Tel. (+ 31-70) 340-2040, Tx. 31 651 epo nl, Fax: (+ 31-70) 340-3016	Authorized officer Rakotondrajaona, C
--	--

INTERNATIONAL SEARCH REPORT

International Application No

PCT/EP 95/00246

C.(Continuation) DOCUMENTS CONSIDERED TO BE RELEVANT

Category *	Citation of document, with indication, where appropriate, of the relevant passages	Relevant to claim No.
A	EP,A,0 503 839 (TELECTRONICS) 16 September 1992 see page 4, column 5, line 34 - page 5, column 8, line 25; claims; figures ---	1-5, 14-20
A	US,A,5 139 020 (KOESTNER ET AL.) 18 August 1992 cited in the application see column 8, line 18 - column 13, line 6; figures ---	1-5,16, 19,20
A	US,A,3 938 502 (BOM) 17 February 1976 cited in the application see column 4, line 21 - column 7, line 63; figures -----	1,16-20

INTERNATIONAL SEARCH REPORT

information on patent family members

International Application No

PCT/EP 95/00246

Patent document cited in search report	Publication date	Patent family member(s)	Publication date
EP-A-0474957	18-03-92	EP-A- 0474958	18-03-92
		US-A- 5316001	31-05-94
		US-A- 5243976	14-09-93
		US-A- 5318595	07-06-94

US-A-5183040	02-02-93	NONE	

US-A-4802490	07-02-89	US-A- 4637401	20-01-87
		CA-A- 1241580	06-09-88
		EP-A, B 0200758	12-11-86
		JP-T- 62500703	26-03-87
		WO-A- 8602540	09-05-86
		US-A- 4674336	23-06-87

EP-A-503839	16-09-92	US-A- 5188106	23-02-93
		JP-A- 6246010	06-09-94

US-A-5139020	18-08-92	NONE	

US-A-3938502	17-02-76	DE-A- 2308443	30-08-73
		FR-A, B 2173115	05-10-73
		GB-A- 1402192	06-08-75
		JP-C- 1127735	14-12-82
		JP-A- 48098692	14-12-73
		JP-B- 57017532	12-04-82
		NL-A- 7202282	24-08-73
		US-A- 3827115	06-08-74
		NL-A- 7203176	12-09-73
