

N. JEROME.

Clock.

No. 1,200.

Patented June 27, 1839.

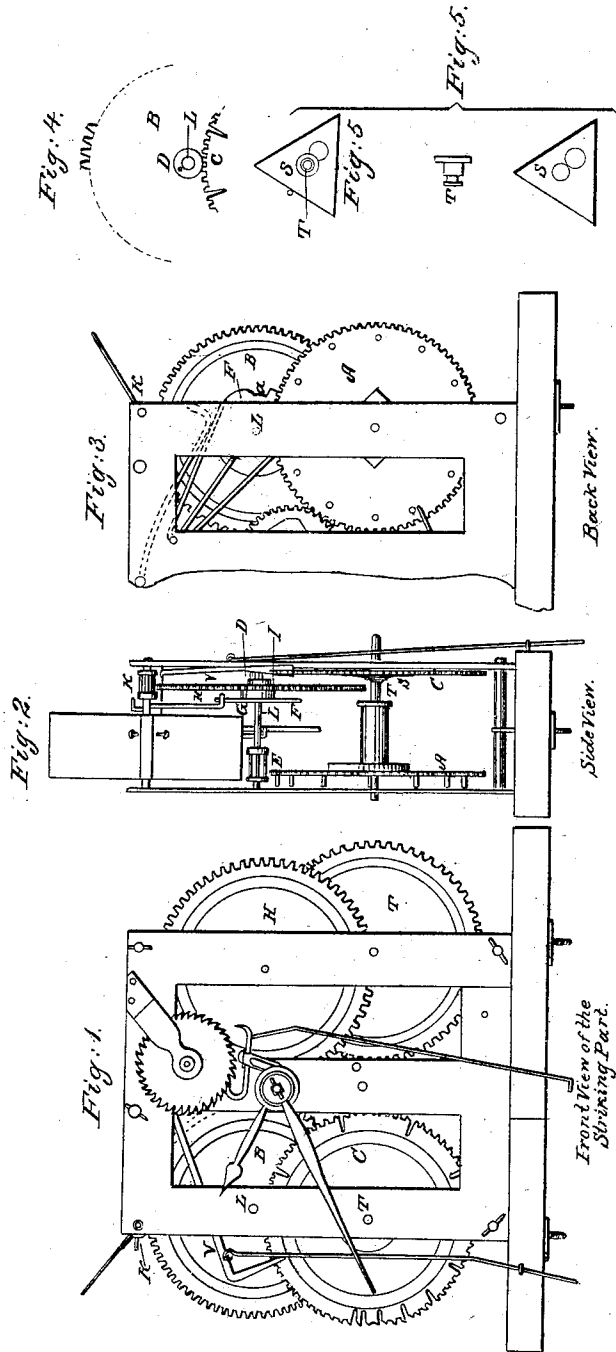

UNITED STATES PATENT OFFICE.

NOBLE JEROME, OF BRISTOL, CONNECTICUT.

STRIKING PART OF CLOCKS.

Specification of Letters Patent No. 1,200, dated June 27, 1839.

To all whom it may concern:

Be it known that I, NOBLE JEROME, of Bristol, in the county of Hartford and State of Connecticut, have invented a new and useful Improvement in the Construction of Clockwork, which is described as follows.

In the striking part of my clock I have but two principal wheels, generally denominated the first and second strike wheels, and a count wheel; without the use of a third or fourth wheel as is usually required to compose a perfect striking part.

The nature of my invention consists in the manner in which my count wheel is constructed of one single piece of metal, with grooves at intervals between the teeth for the reception of the detent or count wire, instead of attaching a separate plate for that purpose, as is usual, and thereby cheapening its construction, and rendering it more simple, and less liable to variation than the usual mode. Also in placing my count wheel upon a stud or socket on the inside of the front plate of the frame through which the barrel arbor passes, where it is secured by a spring to keep it to its place. Also in moving my count wheel by means of a single dog or pin, attached to the axle of the first strike pinion, in connection with a small circular plate attached to the same axle, and revolving with it, and having a notch or groove in its periphery for the purpose of raising and lowering the detent or count wire,—and also to stop the striking of the hammer at the proper time.

Figure 1, front view of striking part; Fig. 2, side view; Fig. 3, back view; Fig. 4, section showing pin D; Fig. 5, section showing stud T and spring S.

Similar letters refer to similar parts in the figures.

My first strike wheel A, Figs. 2 and 3, is attached to the barrel and revolves with it, and drives the first strike pinion E, Fig. 2. My second strike wheel B, Figs. 1, 2, 3, 4, is hung on the axle L of the first strike pinion E, and near the front end of the same and revolves with it, and drives the fly pinion K, Figs. 1, 2, 3.

On the axle L of the first strike pinion E, and directly back of the second strike wheel B, I attach a small circular plate F, Figs. 2, 3, which revolves with it, having a single groove or notch G in its periphery for the purpose of raising and lowering the detent

or count wire V sufficient to escape the teeth of the count wheel C as it revolves, and also to stop the striking of the hammer at the proper time, and to the same axle L of the first strike pinion E and parallel with it, and in front of the second strike wheel B, I also attach a dog or pin D, Figs. 2 and 4, which revolves with it, and answers to the teeth of the count wheel C, and at every revolution, moves it forward one tooth to each stroke of the hammer, regularly.

I construct my count wheel C of one solid piece of metal, with grooves at intervals between the teeth, for the detent or count wire V to drop into, instead of attaching a separate plate for that purpose, as usual. I place my count wheel C on a stud or socket T which is attached and made fast to the inside of the front plate of the frame, through which the barrel arbor passes, and where I secure the said count wheel by a spring S, at which place it is moved around by the dog or pin D, as above described.

My detent or count wire V is raised and lowered by means of a crooked wire being attached to the same shaft in which the count wire is inserted and sliding on the periphery of the small circular plate F, which is attached, and revolves with the second strike wheel B, and which at every revolution falls into the notch G of the small circular plate F. As it passes around it also raises the detent or count wire V sufficient for the teeth of the count wheel to pass, and when the count wire V drops into the groove of the count wheel C, the above described crooked wire falls deep enough into the notch G of the small circular plate F, to stop the striking part—which is again raised out a little before the clock strikes by means of the long lift wire.

I claim no improvement in the construction of the wire work, it being substantially the same as other clocks now in use.

What I do claim as my invention, and desire to be secured by Letters Patent, consists in—

1. Placing the count wheel C on the stud or socket T and confining it with the spring S as above described.

2. I also claim the construction of my count wheel C of one single plate of metal, with grooves at intervals between the teeth, for the reception of the count wire V in the manner herein described.

3. I also claim the moving of the count

wheel by a single dog or pin D being at-
tached to the second strike wheel B and
parallel with its axis, in combination with
the small circular plate F being attached
5 to the same axis, and revolving with it as
heretofore stated; all of which I claim sub-
stantially as herein described.

Dated at Hamburg, in Edgefield district,
and State of South Carolina, this 10th day
of June A. D. 1839.

NOBLE JEROME.

Witnesses:

JOHN O. B. FORD,
WELLINGTON FORD.