

(19) World Intellectual Property Organization  
International Bureau



(43) International Publication Date  
14 April 2011 (14.04.2011)

(10) International Publication Number  
**WO 2011/044237 A1**

(51) International Patent Classification:  
*B04B 5/04* (2006.01)

Timothy [AU/AU]; 38 Bayview Road, Tooradin, Victoria 3980 (AU).

(21) International Application Number:  
PCT/US2010/051631

(74) Agent: MYERS BIGEL SIBLEY & SAJOVEC, P.A.;  
P.O. Box 37428, Raleigh, North Carolina 27627 (US).

(22) International Filing Date:  
6 October 2010 (06.10.2010)

(81) Designated States (unless otherwise indicated, for every kind of national protection available): AE, AG, AL, AM, AO, AT, AU, AZ, BA, BB, BG, BH, BR, BW, BY, BZ, CA, CH, CL, CN, CO, CR, CU, CZ, DE, DK, DM, DO, DZ, EC, EE, EG, ES, FI, GB, GD, GE, GH, GM, GT, HN, HR, HU, ID, IL, IN, IS, JP, KE, KG, KM, KN, KP, KR, KZ, LA, LC, LK, LR, LS, LT, LU, LY, MA, MD, ME, MG, MK, MN, MW, MX, MY, MZ, NA, NG, NI, NO, NZ, OM, PE, PG, PH, PL, PT, RO, RS, RU, SC, SD, SE, SG, SK, SL, SM, ST, SV, SY, TH, TJ, TM, TN, TR, TT, TZ, UA, UG, US, UZ, VC, VN, ZA, ZM, ZW.

(25) Filing Language: English

(26) Publication Language: English

(30) Priority Data:  
61/249,058 6 October 2009 (06.10.2009) US

(71) Applicant (for all designated States except US): KBI BIOPHARMA, INC. [US/US]; 1101 Hamlin Road, P.O. Box 15579, Durham, North Carolina 27704 (US).

(72) Inventors; and

(75) Inventors/Applicants (for US only): MEHTA, Sunil [IN/US]; 2109 Jewwood Drive, Morrisville, North Carolina 27560 (US). HERMAN, Tod [US/US]; 5624 Bowater Crossing, Hillsborough, North Carolina 27278 (US). MCMAHON, Joe [US/US]; 102 Falkner Drive, Chapel Hill, North Carolina 27517 (US). WILSON, Stephen [AU/AU]; 40 Maitland Street, Glen Iris, Victoria 3146 (AU). FITZPATRICK, Ian [AU/AU]; 51 Canadian Bay Road, Mount Eliza, Victoria 3930 (AU). CRAIG,

(84) Designated States (unless otherwise indicated, for every kind of regional protection available): ARIPO (BW, GH, GM, KE, LR, LS, MW, MZ, NA, SD, SL, SZ, TZ, UG, ZM, ZW), Eurasian (AM, AZ, BY, KG, KZ, MD, RU, TJ, TM), European (AL, AT, BE, BG, CH, CY, CZ, DE, DK, EE, ES, FI, FR, GB, GR, HR, HU, IE, IS, IT, LT, LU, LV, MC, MK, MT, NL, NO, PL, PT, RO, RS, SE, SI, SK, SM, TR), OAPI (BF, BJ, CF, CG, CI, CM, GA, GN, GQ, GW, ML, MR, NE, SN, TD, TG).

[Continued on next page]

(54) Title: METHODS, SYSTEMS AND APPARATUS FOR MANIPULATING PARTICLES

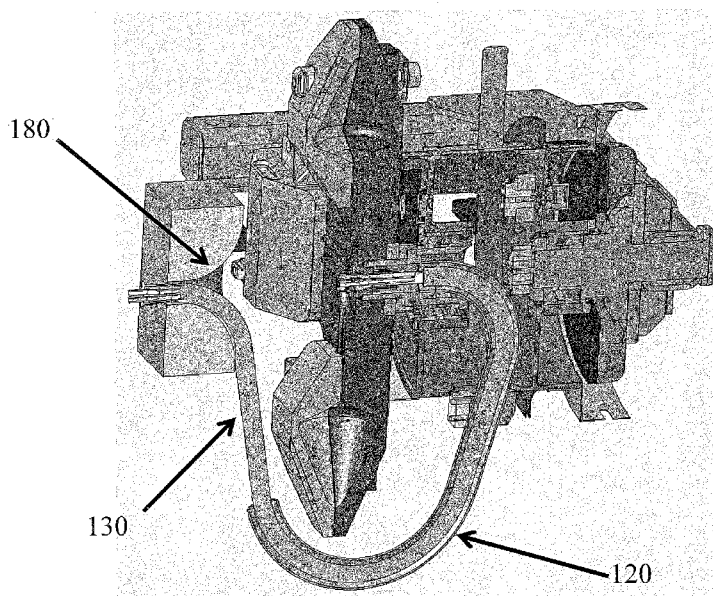

Figure 14D

(57) Abstract: An apparatus for manipulating particles includes : a rotor rotatable at a speed about an axis, the rotor having an outer periphery and front and rear opposite sides; at least one chamber (50) mounted on the rotor, each chamber having an inlet and an outlet; an umbilical assembly rotatable about the axis; and a drive mechanism configured to rotate the umbilical assembly at about one-half the speed of the rotor. The umbilical assembly includes: a curvilinear guide tube (125) connecting to a drum at the rear side of the rotor; a flexible conduit (130) residing in the guide tube; and first and second elongate passageways (135) for each chamber extending through the conduit, wherein the first passageway is in fluid communication with the inlet of a respective chamber and the second passageway is in fluid communication with the outlet of the respective chamber. The passageways are held in a spaced-apart relationship relative to one another.

WO 2011/044237 A1

**Published:**

— with international search report (Art. 21(3))

— before the expiration of the time limit for amending the claims and to be republished in the event of receipt of amendments (Rule 48.2(h))

**METHODS, SYSTEMS AND APPARATUS FOR MANIPULATING PARTICLES**

## FIELD OF THE INVENTION

[0001] The present invention is related to methods, systems, and apparatus that are used for transferring and manipulating particles, as well as components that are useful in systems and apparatus for transferring and manipulating particles, such as continuous flow centrifuges.

## BACKGROUND

[0002] Conventional continuous flow centrifuges raise several concerns with regard to leaking and/or contamination. For example, in conventional continuous flow centrifuges, when a length of tubing is fixedly attached to the rotation axis of a device which contains the fluid material to be centrifuged, the entire length of tubing must be rotated by use of rotating seals or other means to avoid twisting the tubing. However, these seals too frequently become the source of leaks and/or contamination.

[0003] Umbilical-like arrangements for use with continuous flow centrifuges have been disclosed in, for example, U.S. Patent Nos. 4,216,770, 4,419,089, 4,389,206, and 5,665,048. However, these solutions do not adequately address the high stresses and strains imparted on the tubes due to the g-forces created by rotating the centrifuge at high speeds and/or due to the continuous fluid flow necessary to substantially immobilize particles. Moreover, rotating the centrifuge at high speeds creates increased "partial" twisting action of the umbilical system and the tubes contained therein, and the arrangements disclosed to date do not allow the umbilical system and the tubes contained therein to be rotated at a high rate of speed for an acceptable amount of time before failing. In other words, it is believed that the aforementioned solutions simply do not allow the systems to be "scaled up" to an appreciable degree and do not allow the system to be rotated at high rates of speed without rapid and catastrophic failure of the tubing system.

[0004] For small-scale operations, the elimination of rotary seals or the like may address some contamination concerns with regard to conventional continuous flow centrifuges. However, other contamination concerns remain. For example, the fluid flow paths may become contaminated over time (*e.g.*, after more than one use), unless the utmost care is taken in cleaning and/or sterilization. A disposable fluid flow path (or multiple disposable fluid flow paths) could eliminate the need for expensive and time-consuming cleaning, and could help ensure contamination-free operations. The disposable fluid flow

paths would preferably be easily replaceable, and would be adaptable to a system that would allow the system as a whole to be "scaled-up," as discussed above.

#### SUMMARY

[0005] According to some embodiments of the present invention, an apparatus for manipulating particles includes: a rotor rotatable at a speed about an axis, the rotor having an outer periphery and front and rear opposite sides; at least one chamber mounted on the rotor, each chamber having an inlet and an outlet; an umbilical assembly rotatable about the axis; and a drive mechanism configured to rotate the umbilical assembly at about one-half the speed of the rotor. The umbilical assembly includes: a curvilinear guide tube connecting to a drum at the rear side of the rotor; a flexible conduit residing in the guide tube; first and second elongate passageways for each chamber extending through the conduit, wherein the first passageway is in fluid communication with the inlet of a respective chamber and the second passageway is in fluid communication with the outlet of the respective chamber. The passageways are held in a spaced-apart relationship relative to one another.

[0006] In some embodiments, the first and second passageways for each chamber comprise corresponding first and second flexible tubes that extend through at least a major portion of a length of the conduit. Potting material within the conduit is configured to hold the tubes in the spaced-apart relationship relative to the one another and hold the tubes in a spaced-apart relationship relative to the conduit. The potting material may be further configured to restrict movement of the tubes relative to the conduit and/or restrict movement of the tubes relative to one another.

[0007] In some embodiments, the umbilical assembly further includes a flexible member extending through at least a major portion of a length of the conduit, wherein the flexible member extends substantially along a centerline of the conduit, and wherein the flexible tubes surround the flexible member. The potting material may be further configured to restrict movement of the tubes relative to the flexible member.

[0008] Each chamber may be a flexible translucent or transparent fluid chamber, and the apparatus may further include at least one chamber holder pivotably mounted to the front side of the rotor, wherein each chamber holder is configured to releasably enclose a respective chamber. Each chamber holder may include a window to allow visual access to the enclosed chamber.

[0009] Each chamber may include a substantially conical body portion and a flange extending about at least a portion of a perimeter of the conical body portion. The flange

includes an inlet fluid path and an outlet fluid path, wherein the first flexible tube connects with the flange inlet fluid path of a respective chamber and the second flexible tube connects with the flange outlet fluid path of the respective chamber. The flange inlet and outlet paths may be substantially parallel along a segment extending from a point at which the first and second tubes connect with the flange inlet and outlet paths.

[0010] In some embodiments, the conduit and passageways are integrated as a flexible extrusion with an outer wall and internal elongate channels that define the spaced-apart passageways.

[0011] Each chamber may include a substantially conical body portion and a flange extending about at least a portion of a perimeter of the conical body portion. The flange includes an inlet fluid path and an outlet fluid path, wherein the first passageway is in fluid communication with the flange inlet fluid path of a respective chamber and the second passageway is in fluid communication with the flange outlet fluid path of the respective chamber. A first tube may connect the first passageway and the flange inlet fluid path and a second tube may connect the second passageway and the flange outlet fluid path, and the flange inlet and outlet paths may be substantially parallel along a segment extending from a point at which the first and second tubes connect with the flange inlet and outlet paths. A connector may be included at each of the first and second passageways, with one connector configured to connect the first tube with the first passageway and the other connector configured to connect the second tube with the second passageway.

[0012] The drive mechanism may include gears. The gears may be at least partially enclosed by the drum. The conduit may include proximal and distal opposite ends, wherein the conduit distal end connects to the rotor. In some embodiments, the conduit distal end has a substantially hexagonally shaped coupling.

[0013] In some embodiments, the umbilical assembly includes a plurality of spaced-apart flexible holders in the conduit to hold the passageways in the spaced-apart relationship.

[0014] In some embodiments, the at least one chamber comprises a plurality of chambers mounted on the rotor in a spaced-apart relationship.

[0015] According to other embodiments of the present invention, a disposable fluid path for use with a continuous flow centrifuge including a rotor having an outer periphery and front and rear opposite sides includes: at least one chamber mounted on the rotor, each chamber having an inlet and an outlet; a flexible conduit curving around the outer periphery of the rotor and connecting to the rotor; first and second flexible tubes for each chamber extending through the conduit, wherein the first tube is in fluid communication with the inlet

of a respective chamber and the second tube is in fluid communication with the outlet of the respective chamber; and potting material within the conduit, wherein the potting material is configured to hold the tubes in a spaced-apart relationship. The potting material may be further configured to restrict movement of the tubes relative to the conduit and/or relative to one another.

[0016] In some embodiments, the disposable fluid path further includes a flexible member extending through the conduit, wherein the flexible member extends substantially along a centerline of the conduit, and wherein the flexible tubes surround the flexible member. The potting material may be further configured to restrict movement of the tubes relative to the flexible member.

[0017] According to other embodiments of the present invention, an umbilical assembly for use with a continuous flow centrifuge having a rotor and at least one chamber having an inlet and an outlet attached to the rotor includes: a curvilinear guide tube connecting to a drum at the rear side of the rotor; a flexible conduit residing in the tube; first and second flexible tubes for each chamber extending through at least a major portion of a length of the conduit, wherein the first tube is in fluid communication with the inlet of a respective chamber and the second tube is in fluid communication with the outlet of the respective chamber; and potting material within the conduit, wherein the potting material is configured to hold the tubes in a spaced-apart relationship. The potting material may be further configured to restrict movement of the tubes relative to the conduit and/or relative to one another.

[0018] In some embodiments, the umbilical assembly further includes a flexible member extending through the conduit, wherein the flexible member extends substantially along a centerline of the conduit, and wherein the flexible tubes surround the flexible member. The potting material may be further configured to restrict movement of the tubes relative to the flexible member.

[0019] According to other embodiments of the present invention, an umbilical assembly for use with a continuous flow centrifuge having a rotor and at least one chamber attached to the rotor includes a flexible extrusion comprising first and second spaced-apart passageways therein for each chamber, wherein the first passageway is in fluid communication with an inlet of a respective chamber and the second passageway is in fluid communication with an outlet of the respective chamber.

[0020] According to other embodiments of the present invention, a disposable fluid path for use with a continuous flow centrifuge having a rotor includes a first disposable

section and a second disposable section. The first disposable section includes: at least one chamber configured to be held on the rotor, wherein each chamber has an inlet and an outlet; and first and second tubes for each chamber, wherein the first tube is configured to be in fluid communication with the inlet of a respective chamber and the second tube is configured to be in fluid communication with the outlet of the respective chamber. The second disposable section includes: tubing in fluid communication with at least one container; the tubing configured to fit within one or more valves.

[0021] In some embodiments, the first disposable section includes return tubing in fluid communication with the at least one container. In some embodiments, the second disposable section includes return tubing in fluid communication with the at least one container. The first and second disposable sections may be configured to be connected using a sterile tube welding process.

[0022] In some embodiments, each chamber is a flexible translucent or transparent fluid chamber, wherein the chamber includes a substantially conical body portion. The chamber also includes a flange extending about at least a portion of a perimeter of the substantially conical body portion, and the flange includes an integral inlet fluid path and an integral outlet fluid path. The first tube connects with the flange inlet fluid path of a respective chamber and the second tube connects with the flange outlet fluid path of the respective chamber. The flange inlet and outlet fluid paths may be substantially parallel along a segment extending from the point at which the first and second tubes connect with the flange inlet and outlet fluid paths.

[0023] According to other embodiments of the present invention, a centrifugal fluid processing system includes: a housing having an interior cavity with an access aperture extending from an external surface of the housing to the interior cavity; a plurality of fluid chambers held in spaced apart relationship on a rotor in the interior cavity; a flexible conduit holding a plurality of flexible tubes in a spaced-apart relationship therein, the flexible conduit extending from a location that is external to the housing through the access aperture and into the interior cavity, wherein the plurality of tubes includes first and second tubes for each chamber, wherein the first tube is in fluid communication with an inlet of a respective chamber and the second tube is in fluid communication with an outlet of the respective chamber, wherein the flexible conduit comprises a solid flexible material that substantially fills an internal volume of the conduit and surrounds the flexible tubes, with the solid flexible material configured to hold the flexible tubes in the spaced-apart relationship; a substantially rigid curvilinear guide tube holding a portion of the flexible conduit in the

interior cavity; and a drive mechanism configured to rotate the guide tube at a first speed and the rotor and the fluid chambers at a second speed, wherein the second speed is about twice the first speed.

[0024] According to other embodiments of the present invention, a centrifugal fluid processing system includes: a housing having an interior cavity with an access aperture extending from an external surface of the housing to the interior cavity; a plurality of fluid chambers held in spaced apart relationship on a rotor in the interior cavity; a flexible conduit including a plurality of spaced-apart passageways therein, the flexible conduit extending from a location that is external to the housing through the access aperture and into the interior cavity, wherein the plurality of tubes includes first and second passageways for each chamber, wherein the first passageway is in fluid communication with an inlet of a respective chamber and the second passageway is in fluid communication with an outlet of the respective chamber; a substantially funnel-shaped support with an open center passage, the support having a shape that tapers outward as it extends further into the interior cavity, wherein the support surrounds the flexible conduit with a centerline of the funnel shaped support being in line with a centerline of the access aperture; a substantially rigid curvilinear guide tube holding a portion of the flexible conduit in the interior cavity; and a drive mechanism configured to rotate the guide tube at a first speed and the rotor and the fluid chambers at a second speed, wherein the second speed is about twice the first speed.

[0025] According to other embodiments of the present invention, a centrifugal fluid processing system includes: a housing having an interior cavity with an access aperture extending from an external surface of the housing to the interior cavity; a plurality of flexible translucent or transparent fluid chambers having an inlet and an outlet held in spaced-apart relationship on a rotor in the interior cavity, wherein each chamber includes a substantially conical body portion, each chamber including a flange extending about at least a portion of a perimeter of the conical body portion, the flange including an inlet fluid path and an outlet fluid path, wherein the flange inlet fluid path is in fluid communication with the inlet of the chamber and the flange outlet fluid path is in fluid communication with the outlet of the chamber; a flexible conduit including a plurality of elongate spaced-apart passageways therein, the flexible conduit extending from a location that is external to the housing through the access aperture and into the interior cavity, wherein the plurality of passageways includes first and second passageways for each chamber, and wherein the first passageway is in fluid communication with the flange inlet fluid path of a respective chamber and the second passageway is in fluid communication with the flange outlet fluid path of the respective



chamber; a substantially rigid curvilinear guide tube holding a portion of the flexible conduit in the interior cavity; a drive mechanism configured to rotate the guide tube at a first speed and the rotor and the fluid chambers at a second speed, wherein the second speed is about twice the first speed; and a plurality of substantially rigid chamber holders in the interior cavity, each sized and configured to releasably hold a respective flexible chamber attached to the rotor.

[0026] According to other embodiments of the present invention, a method of manipulating particles includes providing: at least one chamber on a rotor having an outer periphery, each chamber having an inlet and an outlet; a flexible conduit with first and second spaced-apart passageways therein for each chamber, wherein the first passageway is in fluid communication with the inlet of a respective chamber and the second passageway is in fluid communication with the outlet of the respective chamber; and a substantially rigid curvilinear guide tube holding a portion of the conduit therein and curving around the outer periphery of the rotor. The method further includes: rotating the rotor and the at least one chamber at a first speed, thereby creating a centrifugal force field; rotating the guide tube and conduit therein at a second speed, wherein the second speed is about one-half the first speed, thereby inhibiting the first and second passageways for each chamber from fully twisting; flowing media and particles into a respective chamber using the first passageway, wherein a continuous flow of media and particles creates a fluid force that substantially opposes the centrifugal force field, thereby immobilizing at least some of the particles in a fluidized bed in the respective chamber; and flowing media out of the respective chamber and through the second passageway.

[0027] It is noted that aspects of the invention described with respect to one embodiment, may be incorporated in a different embodiment although not specifically described relative thereto. That is, all embodiments and/or features of any embodiment can be combined in any way and/or combination. Applicant reserves the right to change any originally filed claim or file any new claim accordingly, including the right to be able to amend any originally filed claim to depend from and/or incorporate any feature of any other claim although not originally claimed in that manner. These and other objects and/or aspects of the present invention are explained in detail in the specification set forth below.

#### BRIEF DESCRIPTION OF THE FIGURES

[0028] **Figure 1** is a side perspective view of a system according to some embodiments of the present invention.

[0029] **Figure 2** is an opposing side perspective view of the system of **Figure 1**.

[0030] **Figure 3** is a side perspective view of an interior portion of the system of **Figure 1**, illustrating internal components.

[0031] **Figure 4** is a side perspective view of an interior portion of the system of **Figure 1**, illustrating internal components.

[0032] **Figure 5A** illustrates a chamber for use in systems and assemblies according to some embodiments of the present invention.

[0033] **Figure 5B** illustrates a chamber holder for use in systems and assemblies according to some embodiments of the present invention.

[0034] **Figure 6** illustrates a chamber and chamber holder in position in the system of **Figure 1** according to some embodiments of the present invention.

[0035] **Figure 7** is a top perspective view of a disposable chamber according to some embodiments of the present invention.

[0036] **Figure 8** is a perspective view of an umbilical assembly according to some embodiments of the present invention.

[0037] **Figure 9A** is cross-sectional view of a portion of an umbilical assembly according to some embodiments of the present invention.

[0038] **Figure 9B** illustrates a portion of an umbilical assembly according to some embodiments of the present invention.

[0039] **Figure 10** is a perspective view of an umbilical assembly according to some embodiments of the present invention.

[0040] **Figure 11** is a perspective view illustrating the umbilical assembly of **Figure 10** connecting with a drum.

[0041] **Figure 12** is a perspective view illustrating a drive mechanism associated with the umbilical assembly of **Figure 10**.

[0042] **Figure 13** is a top view of an umbilical assembly according to some embodiments of the present invention.

[0043] **Figure 14A** is a perspective view of a funnel-shaped ingress/egress port for use with an umbilical assembly according to some embodiments of the present invention.

[0044] **Figure 14B** illustrates a clamp for use with an umbilical assembly according to some embodiments of the present invention.

[0045] **Figure 14C** is a perspective view of a funnel-shaped ingress/egress port for use with an umbilical assembly according to some embodiments of the present invention.

[0046] **Figure 14D** illustrates a funnel-shaped ingress/egress port for use with an umbilical assembly according to some embodiments of the present invention.

[0047] **Figure 15** is a perspective view of a system including disposable flow paths according to some embodiments of the present invention.

[0048] **Figure 16** is another perspective view of the system of **Figure 15**.

[0049] **Figure 17** is flow diagram illustrating operations according to some embodiments of the present invention.

[0050] **Figures 18-20** are simulated screenshots of a display associated with systems according to some embodiments of the present invention.

[0051] **Figure 21** illustrates a portion of an umbilical assembly according to some embodiments of the present invention.

#### DETAILED DESCRIPTION AND EMBODIMENTS OF THE INVENTION

[0052] The present invention now is described more fully hereinafter with reference to the accompanying drawings, in which some embodiments of the invention are shown. This invention may, however, be embodied in many different forms and should not be construed as limited to the embodiments set forth herein; rather, these embodiments are provided so that this disclosure will be thorough and complete, and will fully convey the scope of the invention to those skilled in the art.

[0053] Like numbers refer to like elements throughout. In the figures, the thickness of certain lines, layers, components, elements or features may be exaggerated for clarity.

[0054] The terminology used herein is for the purpose of describing particular embodiments only and is not intended to be limiting of the invention. As used herein, the singular forms "a", "an" and "the" are intended to include the plural forms as well, unless the context clearly indicates otherwise. It will be further understood that the terms "comprises" and/or "comprising," when used in this specification, specify the presence of stated features, steps, operations, elements, and/or components, but do not preclude the presence or addition of one or more other features, steps, operations, elements, components, and/or groups thereof. As used herein, the term "and/or" includes any and all combinations of one or more of the associated listed items.

[0055] Unless otherwise defined, all terms (including technical and scientific terms) used herein have the same meaning as commonly understood by one of ordinary skill in the art to which this invention belongs. It will be further understood that terms, such as those defined in commonly used dictionaries, should be interpreted as having a meaning that is

consistent with their meaning in the context of the specification and relevant art and should not be interpreted in an idealized or overly formal sense unless expressly so defined herein. Well-known functions or constructions may not be described in detail for brevity and/or clarity.

[0056] It will be understood that when an element is referred to as being "on", "attached" to, "connected" to, "coupled" with, "contacting", etc., another element, it can be directly on, attached to, connected to, coupled with or contacting the other element or intervening elements may also be present. In contrast, when an element is referred to as being, for example, "directly on", "directly attached" to, "directly connected" to, "directly coupled" with or "directly contacting" another element, there are no intervening elements present. It will also be appreciated by those of skill in the art that references to a structure or feature that is disposed "adjacent" another feature may have portions that overlap or underlie the adjacent feature.

[0057] Spatially relative terms, such as "under", "below", "lower", "over", "upper" and the like, may be used herein for ease of description to describe one element or feature's relationship to another element(s) or feature(s) as illustrated in the figures. It will be understood that the spatially relative terms are intended to encompass different orientations of the device in use or operation in addition to the orientation depicted in the figures. For example, if the device in the figures is inverted, elements described as "under" or "beneath" other elements or features would then be oriented "over" the other elements or features. Thus, the exemplary term "under" can encompass both an orientation of "over" and "under". The device may be otherwise oriented (rotated 90 degrees or at other orientations) and the spatially relative descriptors used herein interpreted accordingly. Similarly, the terms "upwardly", "downwardly", "vertical", "horizontal" and the like are used herein for the purpose of explanation only unless specifically indicated otherwise.

[0058] Apparatus, systems, and methods for the manipulation of particles are disclosed herein. Also, components useful in apparatus and systems for the manipulation of particles are disclosed herein.

[0059] **Figures 1 and 2** illustrate a system **10** according to some embodiments of the present invention. The system **10** includes an enclosure or housing **15** and a door **20**. The door **20** provides access to the internal components of the system **10**, which are described in more detail below. The door **20** may include a window **25** to provide visual access to the internal components. The door **20** can be hingedly attached to the enclosure **15**, and can be opened by a handle **30**, for example.

[0060] The system **10** includes a flange **35**. The flange **35** may be included with the door **20**, or may be a separate component (*i.e.*, when the door **20** is opened, the flange **35** remains in place). The flange **35** includes an access aperture **40**, through which conduit with channels, passageways, or tubing therein, for example, can extend, as described in more detail below. The door **20** and/or the flange **35** can include a clamp **42**, which is configured to hold the conduit in place and/or release the conduit.

[0061] **Figure 3** illustrates the system **10** with the door **20** opened. As shown, the flange **35** remains in place. **Figure 4** illustrates the system **10** with the door **20** and the flange **35** pivotably opened. The enclosure or housing has an interior cavity **44**, which can be seen in **Figures 3** and **4** when the door **20** and/or the flange **35** have been opened. Some of the internal components of the system **10** are contained in the interior cavity **44**, as seen in **Figures 3** and **4**. Notably, a rotor **45** is configured to be rotatable about an axis. At least one fluid chamber **50** is attached to or mounted on the rotor **45**, so as to be held in a fixed spaced-apart relationship and rotate in response to rotation of the rotor **45**. In some embodiments, a plurality of chambers **50** are attached to or mounted on the rotor **45**; in the illustrated embodiment, four chambers **50** are present.

[0062] An exemplary chamber **50** is illustrated in more detail in **Figure 5A**. The chamber **50** may be substantially cone-shaped or may include a substantially cone-shaped portion, as illustrated, although other shapes are contemplated including, for example, cylindrical, rectangular, frustoconical, pyramidal, etc. The chamber **50** includes an inlet **55** and an outlet **60**. The chamber **50** is typically attached to or mounted on the rotor **45** such that inlet **55** is situated toward the outer periphery of the rotor **45**, and the outlet **60** is typically situated toward the center of the rotor **45** (see **Figure 6**). The chamber **50** is configured to allow fluid flow therethrough while the rotor **45** and the chamber **50** rotate about an axis. The force of fluid flowing from the inlet **55** to the outlet **60** can substantially oppose a centrifugal force created by the rotation of the rotor **45** and the chamber **50**. In this regard, particles can be substantially immobilized in the chamber **50**, such as in a fluidized bed in the chamber **50**, by use of the summation of forces acting on the particles. This action is described in more detail in U.S. Patent Nos. 5,622,819; 5,821,116; 6,133,019; 6,214,617; 6,334,842; 6,514,189; 6,660,509; 6,703,217; 6,916,652; 6,942,804; 7,029,430; and 7,347,943; and U.S. Patent Application Publication Nos. 2005/0266548 and 2008/0264865, the disclosure of each of which is hereby incorporated by reference in its entirety.

[0063] In some embodiments of the present invention, and as illustrated in the figures, the rotor **45** may rotate in a plane substantially coaxial with the gravitational axis (*i.e.*, the

rotor may rotate about a substantially horizontal axis). Particles are substantially immobilized within a fluidized bed within the chamber **50** by use of the summation of the vector forces acting on each particle. Embodiments of such apparatus have been disclosed in U.S. Patent Nos. 5,622,819; 5,821,116; 6,133,019; 6,214,617; 6,660,509; 6,703,217; 6,916,652; 6,942,804; 7,347,943; and U.S. Patent Application Publication Nos. 2005/0266548 and 2008/0264865, the disclosure of each of which is hereby incorporated by reference in its entirety. Though cells and particles are light in weight, their mass is non-zero. Consequently, gravity has a significant effect on the suspended particle or cell, and this effect will increase with time. The weight of the suspended particles or cells causes these particles to settle to the lowest regions of the container, disrupting the balance of forces which initially suspended them in the chamber. As is seen in prior art devices, particles tend to aggregate and the aggregation of these particles into a larger particle results in an increased centrifugal effect which causes the aggregates to migrate to longer radii, eventually causing destabilization of the fluidized bed.

[0064] In some other embodiments of the present invention, the rotor **45** may rotate in a plane substantially transverse to the gravitational axis. In this regard, the rotor **45** may rotate about a substantially vertical axis. Embodiments of such apparatus have been disclosed in U.S. Patent Nos. 4,939,087; 5,674,173; 5,722,926; 6,051,146; 6,071,422; 6,334,842; 6,354,986; 6,514,189; 7,029,430; 7,201,848; and 7,422,693, the disclosure of each of which is hereby incorporated by reference in its entirety. Particles are substantially immobilized within a fluidized bed within the chamber **50** by use of the summation of the vector forces acting on each particle. More particularly, the flow of liquid media acts to create a force which opposes the centrifugal force field created by the rotating chamber(s).

[0065] In still other embodiments, the rotor may rotate about any axis between a horizontal axis and a vertical axis, including, for example, a substantially horizontal axis.

[0066] Referring again to **Figure 5A**, the chamber **50** may include a substantially conical body portion **71**, and a flange **72** that surrounds at least a portion of the conical body portion **71** and/or that extends about at least a portion of a perimeter of the conical body portion **71** (e.g., the flange **72** defines a plane that "wraps around" at least a portion of the chamber **50** and/or the conical body portion **71**). As illustrated, the chamber **50** includes inlet and outlet fluid paths **65**, **70** which may be integrated with the flange **72** of the chamber **50**. As described in more detail below, tubes may connect with the flange inlet and outlet fluid paths **65**, **70**. In these embodiments, the flange inlet and outlet fluid paths **65**, **70** may include

substantially parallel segments **73, 74** extending from the point at which the tubes connect with the flange inlet and outlet fluid paths **65, 70**.

[0067] The chamber **50** may fit within a holder, such as the chamber holder **75** illustrated in **Figure 5B**. The chamber holder **75** can carry all or a significant portion of centripetal forces on the chamber **50**. In some embodiments, the chamber **50** (which may include the inlet and outlet paths **65, 70**) may be disposable, as will be described in more detail below. In some embodiments, such as illustrated in **Figure 7**, the chamber **50** is disposable and made of a polymeric material which may be flexible (*e.g.*, a "bag chamber"). Therefore, the chamber holder **75** may be particularly useful where the chamber **50** is disposable, as the chamber **50** (on its own) may not be able to take the loads experienced when the rotor **45** and chamber **50** is rotating, especially at high speeds and/or for a long period of time. The chamber holder **75** can have increased rigidity or strength relative to the chamber **50**.

[0068] The chamber holder **75** includes cavities **80** sized to matably receive the chamber **50** and the associated inlet and outlet paths **65, 70** (where used) when the chamber holder **75** holds the chamber **50**. Turning to **Figures 6 and 7**, the chamber holder **75** and/or the rotor **45** may include a hinge assembly **85** located on or near the rotor **45** such that the chamber holder **75** can be rotated to open and close over or under the chamber **50**. In this regard, the chamber holder(s) **75** may be configured to releasably enclose the chamber(s) **50**. At least one locating pin **90** may be located on or near the rotor **45**, with the pin(s) **90** configured to mate with corresponding aperture(s) **95** in the chamber holder **75**. In some embodiments, the pin(s) **90** can be located on the chamber holder **75** and the corresponding apertures **95** can be located on or near the rotor **45**. The chamber holder **75** may also include at least one lock **100** configured to mate with corresponding aperture(s) **105** located on or near the rotor **45**. In some embodiments, the lock(s) **100** may be on or near the rotor **45** and the corresponding aperture(s) **105** may be located on the chamber holder **75**. Referring back to **Figure 5B**, the chamber holder **75** may include a top shell **75<sub>1</sub>** and a bottom shell **75<sub>2</sub>**. In some embodiments, the bottom shell **75<sub>2</sub>** may be mounted to or integrated with the rotor **45** and the top shell **75<sub>1</sub>** may be configured to open and close. In other embodiments, the top shell **75<sub>1</sub>** may be mounted to or integrated with the rotor **45** and the bottom shell **75<sub>2</sub>** may be configured to open and close. In these embodiments, the pin(s) **90**, aperture(s) **95**, and/or lock(s) **100** may be located on either the top shell **75<sub>1</sub>** or the bottom shell **75<sub>2</sub>**.

[0069] Referring back to **Figures 3 and 4**, at least one chamber **50** may be attached to or mounted on or held by the rotor **45**. In the illustrated embodiment, four chambers **50** are

attached to or mounted on the rotor **45**. In other embodiments, any number of chambers **50** may be attached to or mounted on the rotor **45**. Also, in the illustrated embodiment, a chamber holder **75** has been rotated closed to cover each of the chambers **50**. The chamber holders **75** may include a window **110**, which may allow an operator to view or allow visual access to the interior of the chamber **50**. Although shown as two pieces **75<sub>1</sub>**, **75<sub>2</sub>** in **Figure 5B**, the chamber holder **75** may comprise a single piece or more than two pieces to hold a respective chamber **50**.

[0070] Turning to **Figure 8**, at least a portion of an umbilical assembly **120** extends through the aperture **40** of the flange **35**. The umbilical assembly **120** can include a curvilinear umbilical guide or guide tube **125**, which curves around or extends about the outer periphery of the rotor **45** and enters into and/or connects to a drum at the rear side of the rotor **45**, as described in more detail below. The guide **125** is typically constructed of a relatively strong material, such as aluminum or steel, to provide strength to the umbilical assembly **120** such that the umbilical assembly **120** can be "spun" about the same axis as the rotor **45**, as described in more detail below. In various embodiments, the guide **125** may extend all the way through the aperture **40** of the flange **35**, may extend to the aperture **40**, or may terminate before reaching the aperture **40**, as illustrated in **Figure 8**.

[0071] Umbilical assemblies described herein may include a flexible conduit residing in the guide tube **120**. First and second elongate channels or passageways for each chamber **50** extend through the conduit. The first channel or passageway is in fluid communication with the inlet **55** of a respective chamber **50** and the second channel or passageway is in fluid communication with the outlet **60** of the respective chamber **50**. The channels or passageways (*i.e.*, all the channels or passageways in the conduit) are preferably held in a spaced-apart relationship relative to one another, as will be described in more detail below. As used herein, the terms "channel" and "passageway" are interchangeable in this context.

[0072] As illustrated in **Figure 8**, for example, the umbilical assembly **120** can include a flexible conduit **130** mounted within and extending along the length of the umbilical guide **125**. In other words, the conduit **130** can reside within the umbilical guide or guide tube **125**. The conduit **130** may comprise a convoluted tube which provides suitable flexibility to bending and can also have high torsional rigidity or strength. The conduit **130** preferably has a sufficiently long fatigue life that can withstand continual flexing associated with centrifugal operation; an exemplary conduit **130** is type FPI available from Flexicon Limited, Birmingham, England, constructed of a modified Polyamide 12. The conduit **130** may have any inside diameter and any outside diameter suitable to accommodate the other



components of the umbilical assembly **120**, described below. In some embodiments, the conduit **130** may have inside diameter of about 35.5 millimeters and an outside diameter of about 42.5 millimeters. In some embodiments, grease or another lubricous material is provided between the umbilical guide **125** and the conduit **130** to reduce friction therebetween.

[0073] The aforementioned channels or passageways of the umbilical assembly **120** can be or include first and second flexible tubes **135** for each chamber **50**. The tubes **135** may be constructed of any flexible material such as any flexible polymer including, but not limited to, PVC. The tubes **135** are mounted within and extend along the length of the conduit **130**. One of the tubes **135** of each chamber **50** can connect with the inlet **55** of the chamber **50** (or, where used, the inlet path **65** of the chamber **50**) and the other can connect with the outlet **60** of the chamber **50** (or, where used, the outlet path **70** of the chamber **50**) (see **Figure 5A**). In the illustrated embodiments, umbilical assembly **120** includes eight flexible tubes **135**, wherein two of the tubes **135** connect with each of the four chambers **50**. The conduit **130** and the tubes **135** extend through the aperture **40** of the flange **35**, regardless of whether the umbilical guide **125** extends that far. In other words, the flexible conduit **130** and the tubes **135** therein extend from a location that is external to the enclosure or housing **15**, through the access aperture **40**, and into the internal cavity **44**. The tubes **135** may have any inner diameter and any outer diameter suitable to fit an appropriate number of tubes **135** within the conduit **130**, which may also include potting material therein, as described in more detail below. In some embodiments, the tubes **135** may have an inner diameter of about 1/4 inch and an outer diameter of about 3/8 inch (*e.g.*, where the conduit **130** has the dimensions described above, and where eight tubes **135** are employed).

[0074] Referring to **Figures 9A** and **9B**, in some embodiments, the umbilical assembly **120** includes a flexible center member **140** mounted within and extending along the length of the conduit **130**. The flexible member **140** extends substantially along a centerline of the conduit **130**, and the flexible tubes **135** form an array and surround the flexible member **140**. The flexible member **140** may comprise a "dummy tube," similar to the tubes **135**, but not in fluid communication with any of the chambers **50**. In other embodiments, the flexible member **140** may be a tube with an open cavity having the same or smaller or larger diameter than the tubes **135**, or may be solid tube, for example of polymeric material. For example, the flexible member **140** may comprise a tube having an inner diameter of about 3/8 inch and an outer diameter of about 9/16 inch, and the tubes **135** may have an inner diameter of about 1/4 inch and an outer diameter of about 3/8 inch. Where the flexible member **140**

comprises a tube, the inside of the tube may include potting material, as described in more detail below. In some other embodiments, the flexible member 140 comprises a tube configured to have fluid flow through the tube. The fluid may provide additional cooling to the umbilical assembly 120, for example.

[0075] The umbilical assembly 120 may also include potting material 145 within the conduit 130. The potting material 145 can separate the tubes 135 from the conduit 130, can separate the tubes 135 from each other, and/or can separate the tubes from the flexible member 140, where used. More specifically, the potting material 145 may be configured to hold the tubes 135 in a spaced-apart relationship relative to one another and/or hold the tubes 135 in a spaced-apart relationship relative to the conduit 130 and/or hold the tubes 135 in a spaced-apart relationship relative to the flexible member 140, where used. The potting material 145 can be useful in restricting movement (*e.g.*, twisting) of the tubes 135 relative to one another during operation, as described in more detail below. In other words, the potting material 145 can "lock" the tubes 135 and/or the conduit 130 together so that the tubes 135 are inhibited from moving relative to one another and/or relative to the conduit 130. As used herein, "potting material" includes any solid flexible material that substantially fills the internal volume of the conduit and surrounds the tubes and/or flexible center member. The potting material 145 can be any suitable material, including a polymer such as polyurethane, for example. An exemplary potting material is F-25 flexible polyurethane, available from BJB Enterprises, Inc., Tustin, California.

[0076] As will be discussed in more detail below, the conduit 130 has opposite proximal and distal ends 130<sub>1</sub>, 130<sub>2</sub>. In some embodiments, the proximal end 130<sub>1</sub> of the conduit 130 and the tubes 135 contained therein extend through the access aperture 40. As illustrated in **Figure 9B**, the proximal end 130<sub>1</sub> of the conduit 130 may include a flange 132 through which the tubes 135 extend. Where potting material is employed, the flange 132 may assist in housing the potting material in the conduit 130. The flange 132 may also assist in proper positioning of the conduit 130 with the tubes 135 contained therein. For example, the flange 132 may be situated on the outside of the aperture 40 (*e.g.*, on the outside of the enclosure 15); the flange 132 may therefore allow an operator to position the proper length of conduit 130 in the interior cavity 44.

[0077] Referring now to **Figures 10-12**, the umbilical assembly 120 curves around or extends about the outer periphery of the rotor 45 and enters a drum 150 at the rear side of the rotor 45. In some embodiments, a portion of the umbilical assembly 120 connects with the drum 150. In the illustrated embodiment, a drive mechanism 155 is driven by a motor 160

and a belt 165. The drive mechanism 155 may include various gears 170, at least some of which may be located within the drum 150. In particular embodiments, the drive mechanism 155 causes the umbilical assembly 120 to rotate about an axis at speed X, and causes the rotor 45 to rotate about the same axis at speed 2X or about speed 2X. In other words, the umbilical assembly 120 rotates at one-half or about one-half the speed of the rotor 45. In some embodiments, the drum 150 is driven at speed X by the motor 160 (the umbilical assembly 120 in turn rotates at speed X), and the drive mechanism 155 includes gearing which causes the rotor 45 to rotate at speed 2X or about speed 2X.

[0078] **Figure 13** illustrates an exemplary arrangement and shape of the umbilical assembly 120. The conduit 130 has opposite proximal and distal ends 130<sub>1</sub>, 130<sub>2</sub>. In some embodiments, the proximal end 130<sub>1</sub> of the conduit 130 and the tubes 135 contained therein extend through the access aperture 40 (see **Figures 15** and **16**, for example). The distal end 130<sub>2</sub> of the conduit 130 extends through the drum 150 and may connect to the rotor 45 to thereby allow the tubes 135 to be fluidly connected with the chambers 50. In some embodiments, and as illustrated, the conduit distal end 130<sub>2</sub> includes a coupling 133. The coupling 133 can couple the conduit 130 to the rotor 45 and therefore allow the tubes 135 to be fluidly connected with the chambers 50. In some embodiments, the coupling 133 has a hexagonal shape, although other shapes are contemplated, including other polygonal shapes.

[0079] In this configuration, the coaxial half-speed rotation of the umbilical assembly 120 inhibits the tubes 135 of the umbilical assembly 120 from being completely twisted during rotation of the rotor 45. The complete scientific explanation for this phenomenon can be found in, for example, U.S. Patent No. 3,586,413 to Adams, the disclosure of which is hereby incorporated by reference herein in its entirety. To summarize, if the rotor 45 has completed a first 360° rotation and the umbilical assembly 120 a 180° half-rotation in the same direction, the tubes 135 of the umbilical assembly 120 will be subjected to a 180° twist in one direction. Continued rotation of the rotor 45 for an additional 360° and umbilical assembly 120 for an additional 180° will result in the tubes 135 of the umbilical assembly 120 being twisted 180° in the other direction, returning the tubes 135 to their original untwisted condition. Thus, the tubes 135 of the umbilical assembly 120 may be subjected to a continuous partial twist or flexure or bending during operation but are never completely rotated or twisted about their own axis.

[0080] This solution can provide advantages over typical continuous flow centrifuges. In conventional mechanisms, when a length of tubing is fixedly attached to the rotation axis of a device which contains the fluid material to be centrifuged, the entire length of tubing

must be rotated by use of rotating seals or other means to avoid twisting the tubing. However, these seals too frequently become the source of leaks and/or contamination.

[0081] In contrast, the umbilical assembly **120** of the present invention provides a transition from the "rotating world," including the rotor **45**, to the "stationary world," such as that area outside the enclosure **15**. Rotary unions and seals are not required, providing a sterile and completely closed system. Other advantages can include the use of disposable components that can be easily replaced, resulting in sterile paths, as described in more detail below.

[0082] Umbilical-like arrangements for use with continuous flow centrifuges have been disclosed in, for example, U.S. Patent Nos. 4,216,770, 4,419,089, 4,389,206, and 5,665,048. However, these solutions do not adequately address the high stresses and strains imparted on the tubes due to the g-forces created by rotating the centrifuge at high speeds and/or due to the continuous fluid flow necessary to substantially immobilize particles. Moreover, rotating the centrifuge at high speeds creates increased torque of the umbilical system and the tubes contained therein, and the arrangements disclosed to date do not allow the umbilical system and the tubes contained therein to be rotated at a high rate of speed for an acceptable amount of time before failing. In other words, it is believed that the aforementioned solutions simply do not allow the systems to be "scaled up" to an appreciable degree and do not allow the system to be rotated at high rates of speed without rapid and catastrophic failure of the tubing system. This is the case, at least in part, because the friction increases as the speed and the scale increase, producing an increased torque of the umbilical system.

[0083] The present invention addresses these deficiencies by providing a more robust umbilical assembly that can withstand higher rotational speeds (and therefore higher g-forces), allowing a system, such as a continuous flow centrifuge, to be "scaled up" to larger sizes without subjecting the umbilical assembly to immediate or rapid catastrophic failure. This is due to the configuration of the umbilical assemblies of the present invention, such as the umbilical assembly **120** illustrated in **Figures 8-14**.

[0084] In this configuration, excessive twisting of the tubes **135** is inhibited during operation (*i.e.*, while the rotor is rotated about the axis at speed 2X and the umbilical assembly is rotated about the axis at speed X). More particularly, excessive twisting of the tubes **135** relative to one another and relative to the conduit **130** is prevented. Put another way, the tubes **135** and the conduit **130** are effectively "locked" together (*e.g.*, by use of the potting material **145**), thereby inhibiting relative movement of the components. In addition,

excessive rubbing of tubes **135** against each other and against the conduit **130** is reduced, if not totally prevented. The result is a tubing system that can experience a relatively long life in a large-scale system that is rotated about the axis at a high rate of speed.

[0085] This is accomplished, in part, by restricting the movement of the tubes **135** within the conduit **130**. The potting material **145** can maintain the tubes **135** in place, and thereby prevent the tubes **135** from excessive twisting relative to the conduit **130**. In other words, the potting material **145** can "lock" the tubes **135** and/or the conduit **130** together, thereby inhibiting movement of the tubes **135** relative to one another and/or relative to the conduit **130**. The potting material **145** can also provide a buffer between the individual tubes **135**, thereby preventing the tubes **135** from rubbing against one another. Moreover, the potting material **145** can provide a buffer between the tubes **135** and the conduit **130**, thereby preventing the tubes **135** from rubbing against the conduit **130** during operation. Rubbing of these components can not only cause continual stress, but can also generate heat, further weakening the components.

[0086] Moreover, where used, the flexible member **140** can serve to maintain the tubes **135** in an organized array around the flexible member **140**, further reducing twisting of the tubes **135**. Where potting material **145** is employed, the potting material **145** can serve to "lock" the conduit **130**, the tubes **135**, and/or the flexible member **140** together, thereby inhibiting movement of the components relative to one another. Moreover, the potting material **145** may serve as a buffer between the tubes **135** and the flexible member **140**, thereby preventing the tubes **135** from rubbing against the flexible member during operation. Rubbing of these components can not only cause continual stress, but can also generate heat, further weakening the components.

[0087] Selection of an appropriate material for the conduit **130** can prevent failure thereof due to rubbing against the umbilical guide **125** during operation. Furthermore, grease or other lubricous material can be applied between the conduit **130** and the guide **125** to further reduce friction and potential failure of the conduit **130** and/or the tubes **135** during operation (*e.g.*, fatigue failure of the conduit **130**). Moreover, the inside of the guide **125** can be polished (*e.g.*, mechanically polished) to further reduce friction between the conduit **130** and the guide **135**. Additionally or alternatively, the inside of the guide **125** and/or the outside of the conduit **130** can be coated with a lubricous material, such as Teflon®, to reduce friction between the two components.

[0088] Using these configurations, a system, such as a continuous flow centrifuge without use of rotary seals or the like, has been successfully "scaled-up" as follows. The

rotor and the chamber(s) can be rotated at speeds of at least 3000 RPM. This corresponds to a g-force of about 1000g at the chamber (*e.g.*, at 1/3 the height of the chamber "cone" or 1/3 chamber height from the "tip" of the chamber). The fluid flow rates through each chamber can be at least 1 liter/minute. Thus, where four chambers are employed, for example, the total flow rate can be at least 4 liters/minute. The volume of each chamber can be at least 1 liter. Thus, where four chambers are employed, for example, the total chamber volume can be at least 4 liters. Of course, lower rotational speeds, flow rates, and/or chamber volumes can be employed for various operations (*e.g.*, the rotational speed of the rotor can range from 0-3000 RPM and/or the fluid flow rate through each chamber can range from 0-1 liters/minute and/or the volume of each chamber can be less than 1 liter). Moreover, it is believed that the aforementioned embodiments and the alternative embodiments disclosed below can allow for a robust system that is "scaled-up" to an even higher degree (*e.g.*, rotational speeds higher than 3000 RPM, flow rates higher than 1 liter/minute per chamber, chamber volumes greater than 1 liter, etc.). More specifically, it is believed that the aforementioned embodiments and the alternative embodiments disclosed below can allow for a robust system that employs rotation speeds of about 10, 25, 50, 100, 250, 500, 750, 1000, 1250, 1500, 1750, 2000, 2500, 3000, 5000, or 10,000 RPM or more or any subrange therein; it is also believed that the aforementioned embodiments and the alternative embodiments disclosed below can allow for a robust system that can produce and withstand g-forces of about 10, 25, 50, 100, 250, 500, 750, 1000, 1250, 1500, 1750, 2000, 2500, 3000, 5000, or 10,000g or more or any subrange therein. Likewise, it is believed that the aforementioned embodiments and the alternative embodiments disclosed below can allow for fluid flow rates of about 0.0001, 0.001, 0.01, 0.1, 0.25, 0.5, 0.75, 1, 1.25, 1.5, 1.75, 2, 2.5, 3, 5, 10, 20, 25, or 50 liters/minute per chamber or more or any subrange therein; it is also believed that the aforementioned embodiments and the alternative embodiments disclosed below can allow for individual chamber volumes of about 0.0001, 0.001, 0.01, 0.1, 0.25, 0.5, 0.75, 1, 1.25, 1.5, 1.75, 2, 2.5, 3, 5, 10, 20, 25, or 50 liters or more or any subrange therein.

[0089] Other embodiments of the umbilical assembly **120** are contemplated. For example, the flexible member along the centerline of the conduit can be omitted. One of the tubes may extend substantially along a centerline of the conduit, with the remaining tubes forming an array and surrounding the center tube. In this regard, the center tube takes the place of the "dummy tube," and it connects with either the inlet or outlet path of one of the chambers. Potting material may be provided to prevent twisting and rubbing, as described in more detail above.

[0090] In still other embodiments, potting material is not required. For example, the umbilical assembly could comprise one solid extrusion with a plurality of channels or passageways extending therethrough. Each channel or passageway would connect with either an inlet or an outlet of one of the chambers. The solid extrusion may be flexible, and may be contained within a guide to provide strength, such as the guide **120** described above.

[0091] An exemplary solid extrusion assembly **330** is illustrated in **Figure 21**. The solid extrusion assembly **330** may form part of the umbilical assembly **120** described herein. More specifically, the solid extrusion assembly **330** may take the place of the conduit **130** and the tubes **135** (as well as the potting material **145** and/or the flexible member **140** where these components are used) in all embodiments described above and below. Thus, it will be understood that the solid extrusion assembly **330** may fit within the guide tube **125** and define the conduit with spaced-apart elongate passageways therein.

[0092] Still referring to **Figure 21**, the solid extrusion assembly **330** includes a solid extrusion **330e**. The solid extrusion is flexible with an outer wall and internal elongate channels or passageways **335** that define the spaced-apart passageways. Similar to the tubes **135** described in detail herein, the passageways **335** are in fluid communication with the chamber(s) **50**. In particular, one passageway **335** is in fluid communication with the inlet **55** of a respective chamber **50** and another, different passageway **335** is in fluid communication with the outlet **60** of the respective chamber **50**. In the illustrated embodiment, the solid extrusion **330e** includes eight passageways **335**, and is therefore configured for use with four chambers **50**. The extrusion **330e** may include greater or fewer than eight passageways **335** as needed.

[0093] As explained above, the extrusion assembly **330** may take the place of at least the conduit **130** in the umbilical assembly **120**. Any differences between the extrusion assembly **330** and the conduit **130** will now be described.

[0094] As described above, the passageways **335** generally take the place of the flexible tubes **135**. However, unlike the tubes **135**, the passageways **335** may not extend all the way to the chamber(s) **50** and/or all the way to connection points outside the enclosure **15** (see **Figures 15** and **16**). Thus, in some embodiments, connectors (such as barbed connectors) may be included or used at one or both ends of each passageway **335**. Connectors at a distal end of the passageways **335** may allow for tubing (which may be similar to the flexible tubing **135** described herein) to connect the passageways **335** with the inlet **55** and outlet **60** of the chamber(s) **50** (or the flange inlet and outlet paths **65**, **70**, where used). Similarly, connectors at a proximal end of the passageways **335** may allow for tubing

(which may be similar to the flexible tubing **135** described herein) to connect the passageways **335** with components outside the enclosure **15**, such as pumps or other tubing, which are described in more detail below.

[0095] In some embodiments, and as illustrated, the solid extrusion assembly **330** includes a sheath **330s**. The sheath **330s** material and configuration may have similar properties and provide similar advantages to the conduit **130** material and configuration described above. In particular, the sheath **330s** may help withstand friction with the guide tube **125** and/or may help transfer torque during operation. In some embodiments, the sheath **330s** may include ridges to minimize contact area with the guide tube **125** and/or to minimize friction during operation. The sheath **330s** may be adhered to or may snugly fit around an outer wall of the solid extrusion **330e**. In some embodiments, the sheath **330s** and the solid extrusion **330e** are sized and configured such that there is an interference fit (perhaps a substantial interference fit) between the two components. In this regard, the sheath **330s** and the solid extrusion **330e** may act as a single unit during operation (*i.e.*, as the extrusion assembly **330**). In some embodiments, the sheath **330s** and the solid extrusion **330e** may be integrated, and in some embodiments the sheath **330s** may be omitted.

[0096] The solid extrusion assembly **330** may provide the same or substantially the same advantages as the conduit **130**, tubes **135**, and potting material **145** as described in detail above. Briefly, the passageways **335** may be positioned in the solid extrusion **330e** such that they are spaced-apart from one another and/or from an outer wall of the extrusion **330e** and/or from the sheath **330s**, where used. The spaced-apart relationship may be maintained during operation, and therefore may help minimize movement/twisting of the passageways **335** relative to one another and/or may help minimize movement/twisting of the passageways **335** relative to the sheath **330s**, where used. The result is a more robust umbilical assembly that can be used in "scaled-up" operations, as described in more detail above.

[0097] The solid extrusion **330e** may comprise polymeric material, such as PVC, platinum-cured silicon, C-Flex, and other similar materials. The sheath **330s**, where used, may comprise materials similar to those described above with regard to the conduit **130**.

[0098] Again, to avoid repetition, the embodiments described above and below will only be described with the umbilical assembly **120** including the conduit **130** and the tubes **135** (and optionally the potting material **145** and/or the flexible member **140**). However, it will be understood that the umbilical assembly **120** may include the extrusion assembly **330**



or simply the extrusion **330e** in place of the conduit **130**, the tubes **135**, and/or the potting material **145**.

[0099] In some embodiments, and as illustrated in **Figures 14A-D**, a funnel **180** is provided on the rear side of the flange **35** and/or the door **20**. The funnel **180** includes an opening **185** opposite the aperture **40**. The funnel **180** is configured to accept at least part of the umbilical assembly **120**. In the illustrated embodiments, the funnel **180** accepts the conduit **130**, with the tubes **135** contained therein. The conduit **130** passes through the opening **185** and the aperture **40** such that at least the tubes **135** extend through the aperture **30**. The tubes **135** can then be connected to additional components, as described in more detail below.

[0100] The funnel **180** can provide for reduced strain/stress on the conduit **130** and the tubes **135** where the conduit makes a final bend before extending through the aperture **30**. In this regard, the funnel **180** provides a controlled bend of the conduit **130** and tubes **135** contained therein. This can reduce the chance of failure of the conduit **130** and/or the tubes **135** at what otherwise would be a high stress concentration point. The centerline of the opening **185** is preferably aligned or substantially aligned with the axis of rotation of the umbilical assembly **120**; otherwise, additional, unnecessary loads could be applied to the conduit **130** and/or the tubes **135**. Also, the funnel **180** preferably has a bend radius that is greater than the minimum dynamic bend radius of the conduit **130**.

[0101] Moreover, the shape of the funnel **180** provides for a consistent bend of the conduit **130** and the tubes **135** contained therein while the umbilical assembly **120** is rotating during operation. The funnel **180** may be machined and/or polished to reduce friction or rubbing while the conduit **130** is rotating within the funnel **180**. In addition, grease or other lubricous material may be applied to the funnel **180** to further reduce friction or rubbing. Additionally or alternatively, the funnel and/or the outer surface of the conduit **130** may be coated with a lubricous material such as Teflon® to reduce friction or rubbing.

[0102] Turning now to **Figures 15** and **16**, the conduit **130** and the tubes **135** are seen protruding from the aperture **40**. At least one pump **200** may be provided on the enclosure **15** or on a panel thereon, or may be provided away from the enclosure **15**. At least one valve may be provided on the enclosure **15** or on a panel thereon, or may be integrated with the tubing shown on the right side of the enclosure **15**, or may be provided away from the enclosure **15**. For example, one or more pinch valves may be provided on the enclosure **15**, with the pinch valves configured to allow tubing to be inserted therethrough such that the tubing can be squeezed (or pinched) closed or partially closed.

[0103] **Figure 17** illustrates an exemplary flow diagram of the system. The system may include two sets: the chambers/umbilical set and the valve/fluid path set. The chambers/umbilical set may include at least the chamber(s) **50**, the conduit **130**, and the tubes **135** within the conduit **130**. In the illustrated embodiment, the tubes **135** in fluid communication with the inlet paths **65** of the chambers **50** may connect with the pump **200** (see also **Figures 15** and **16**). Also in the illustrated embodiment, the tubes **135** in fluid communication with the outlet paths **70** of the chambers **50** may connect with at least one return tube **205** (see **Figures 15** and **16**). On the opposite side of the pump **200**, tubes **210** may connect with a harness or manifold **215**, which connects the chambers/umbilical set with the valve/fluid path set. In some embodiments, the two disposable sets can be connected by a sterile tube welding process. The disposable sets can be supplied sealed and/or sterilized. By employing a sterile tube welding process, the disposable sets can be connected without using any sort of connector (*e.g.*, harness, manifold, etc.), and the disposable sets do not need to be "opened," which could result in a loss of sterility.

[0104] The valve/fluid path set typically comprises tubing and/or valves, which may be integrated with the tubing. In some embodiments, the valve/fluid path set is configured to be routed through one or more valves, such as pinch valves included on the enclosure, for example. In the embodiment illustrated in **Figures 15** and **16**, the valve/fluid path set includes the tubing seen on the right side of the enclosure **15**. In some embodiments, the valve/fluid path set includes the return tube(s) **205**. It is noted that, although the tubes are shown as "broken" in **Figures 15** and **16**, the tubes **135** protruding from the aperture **40** of the flange **35** will typically connect with the pump **200** and/or the return tube(s) **205**. The return tube(s) **205** and/or the tubes **135** running to the pump **200** may be routed through the handle **30** of the door **20** and/or kept in place by one or more holders **220**, such as hooks.

[0105] As seen in the flow diagram of **Figure 17**, the valve/fluid path set can connect to various containers, such as a bioreactor **230**, a waste media container **235**, a clean media container **240**, and/or a cell harvest container **245**. The various containers will typically be located away from the enclosure **15**, although at least some of the containers may be contained within the enclosure **15** in some embodiments. In the embodiment illustrated in **Figures 15** and **16**, the lower (open) portions of the tubes on the right side of the enclosure **15** may connect with various containers, such as the containers described above. The valve/fluid path set may be configurable to perform various operations, as will be summarized in more detail below. At least one secondary pump **250** may be included on the enclosure **15** or away

from the enclosure **15**; the secondary pump **250** may be useful in at least some of these various operations.

[0106] At least some of the components described herein may be disposable. For example, the chambers **50**, the conduit **130**, and/or the tubes **135** contained therein may be disposable. As described above, the disposable chambers **50** may be constructed of a flexible or resilient polymer, such as a transparent or translucent polymer, thereby forming a "bag chamber." In some embodiments, the disposable chambers **50** may be thermoformed. In some embodiments, the material of the disposable chambers **50** may be relatively thin (*e.g.*, less than 1 mm thick medical grade PVC). In other embodiments, the material of the disposable chambers **50** may be another material (*e.g.*, FEP, C-Flex, blow molded EVA, low-density polyethylene, etc.), to permit compliance with good manufacturing practice (cGMP). The disposable chambers **50** may include inlet and outlet fluid paths **65**, **70** (which may be integrated), as illustrated in **Figure 5A**, and as described in more detail above. The chamber holders **75** (see **Figure 5B**) can inhibit failure of the disposable chambers **50** by accommodating the majority of or all of the loads experienced due to rotation of the rotor **45** and the chambers **50**.

[0107] A system comprising two separate disposable fluid paths is also contemplated. In this system, the two sets described above (*i.e.*, the chambers/umbilical set and the valve/fluid path set) may be separately disposable. For example, referring to **Figures 15-17**, the chambers **50**, the conduit **130**, and the tubes **135** contained therein (leading up to or extending just past the pump **200**) may comprise a first disposable flow path (Set #1). The tubing and/or valves to the right of the harness or manifold **215** may comprise a second disposable flow path (Set #2). The return tube(s) **205** will typically be included in disposable Set #2, but may be included in either disposable flow path.

[0108] The disposable fluid path(s) can provide advantages over conventional continuous flow centrifuges and like apparatus. Systems that do not employ disposable flow paths generally have to adhere to Cleaning-in-Place (CIP) and Sterilization-in-Place (SIP) procedures and standards. This is especially the case for those systems that perform operations that are sensitive to contamination, such as cell culturing/harvesting and blood processing, for example. The disposable flow paths described herein can eliminate the need to perform CIP and SIP procedures. Furthermore, the use of completely disposable fluid paths permits compliance with good manufacturing practice (cGMP). The paths can be provided as sterile components ready for insertion and use.

[0109] As discussed above, the systems disclosed herein can be used to perform a number of processing, harvesting, etc. methods and operations. Exemplary methods and operations are disclosed in detail in co-pending and commonly owned International Application Nos. PCT/US2009/004113 (International Publication No. WO 2010/008563) and PCT/US2009/004137 (International Publication No. WO 2010/008579), both filed July 16, 2009, the disclosures of each of which are hereby incorporated by reference herein in their entirety. A brief overview of some of the methods and operations follow, with reference to **Figure 17**.

[0110] In continuous flow centrifugation operations, media containing particles such as cells will be fed in the rotating chambers **50** to form a fluidized bed of cells. After the chambers **50** are filled with cells, the flow will be reversed to empty out the chambers **50**. The system (*i.e.*, the rotors and the chambers) does not need to stop rotating throughout this application. The cycle can be repeated to concentrate cells from large volumes.

[0111] Similarly, in perfusion operations, particles such as cells are immobilized in the rotating chambers **50** in fluidized beds for culturing and/or harvesting. For example, cells and media may be removed from the bioreactor **230** and transported to the chambers **50**. A continuous flow of media and cells substantially opposes the centrifugal force created by the rotating chambers **50**, thereby immobilizing the cells in a fluidized bed. Using a perfusion cycle, the cells are provided with fresh media continuously and spent media is removed, such as to the waste container **235**. The cells can then be removed from the chambers **50**, perhaps by reversing the fluid flow and returning the cells to the bioreactor **230** or the cell harvest container **245**.

[0112] The systems disclosed herein can also perform media exchanges during cell culture or harvest. In this application, cell culture is first fed to the rotating chambers **50** to form a bed of fluidized cells, and then a new media or buffer is fed through the inlet paths **65** of the chambers **50** to be perfused through the bed. For example, the new media or buffer may be introduced from the clean media container **240**. After the cells are washed with the media or buffer, the chambers **50** are emptied out by reversing the flow (*i.e.*, introducing media to the outlet paths **70** of the chambers **50**). It is noted that the media/ buffer exchange application could be used prior to additional processes such as transfection, cell dispensing, seeding a bioreactor, etc.

[0113] The systems are also capable of separating population of cells based on density and/or size. In this application, fluid containing different populations of cells will be fed into the rotating chambers **50**. Cells will be separated by modulating the fluid feed rate and/or the

centrifugal force (*i.e.*, the rotational speed of the rotor). Once the fluid feed rate and centrifugal forces are adjusted appropriately, lighter/smaller cells will exit out of the chambers **50** with media. After a cell bed is formed, fresh media or buffer could be used to separate another population by once again adjusting the feed rate and/or centrifugal force. This process can be repeated several times to separate multiple populations of cells that differ by density and/or size. Finally heavier/larger cells are harvested by reversing the flow of fresh media.

[0114] These are just a sampling of the processes that can be performed by the disclosed systems. Other processes include cell dispensing, transfection, eletroporation, selection/purification/enrichment (such as by using affinity matrices), fractionation of proteins/biomaterials, associating particles with and/or removing particles from scaffolding material, and coating particles. These processes are described in detail in the aforementioned applications.

[0115] Referring again to **Figures 15** and **16**, a display **260** may be provided on the enclosure **15**, or may be provided on a panel attached or adjacent to the enclosure **15**, or may be provided away from the enclosure **15**. The display **260** is connected (*e.g.*, directly or wirelessly) to at least one controller (not shown). There may be controllers associated with the various components of the system, including the motor, the pump(s), the valves, etc. There may be one controller associated with all components or certain components may have dedicated controllers.

[0116] Simulated screenshots of the display **260** are illustrated in **Figures 18-20**. The display **260** may allow parameters to be entered and data or progress to be read by an operator. The display may include touch screen buttons that dictate the operation of various components, as seen in **Figure 18**. In some embodiments, there is a separate user input device such as a keyboard; in other words, the display may not employ a touch screen.

[0117] In some embodiments, a light source and/or a camera may be included on the enclosure or in the interior cavity of the enclosure. The light source and/or the camera may be useful to illuminate the chamber(s) and/or capture images of the chamber(s) (*e.g.*, the interior of the chamber(s) during operation). The captured images may be useful to provide feedback to the operator and/or the system as to the progress of the particular process taking place within the chamber(s). The camera may be in communication with the display (either directly or via a controller), such that the images may be transmitted to the display, for example. The controller(s) and/or software associated with the controller(s) may automatically correlate captured images with a particular chamber.

[0118] The foregoing is illustrative of the present invention and is not to be construed as limiting thereof. Although a few exemplary embodiments of this invention have been described, those skilled in the art will readily appreciate that many modifications are possible in the exemplary embodiments without materially departing from the teachings and advantages of this invention. Accordingly, all such modifications are intended to be included within the scope of this invention as defined in the claims. The invention is defined by the following claims, with equivalents of the claims to be included therein.

That Which is Claimed is:

1. An apparatus for manipulating particles, the apparatus comprising:  
a rotor rotatable at a speed about an axis, the rotor having an outer periphery and front and rear opposite sides;  
at least one chamber mounted on the rotor, each chamber having an inlet and an outlet;  
an umbilical assembly rotatable about the axis, the umbilical assembly comprising:  
a curvilinear guide tube connecting to a drum at the rear side of the rotor;  
a flexible conduit residing in the guide tube; and  
first and second elongate passageways for each chamber extending through the conduit, wherein the first passageway is in fluid communication with the inlet of a respective chamber and the second passageway is in fluid communication with the outlet of the respective chamber; and  
a drive mechanism configured to rotate the umbilical assembly at about one-half the speed of the rotor;  
wherein the passageways are held in a spaced-apart relationship relative to one another.
2. The apparatus of Claim 1, wherein the first and second passageways for each chamber comprise corresponding first and second flexible tubes that extend through at least a major portion of a length of the conduit, the apparatus further comprising potting material within the conduit, the potting material configured to hold the tubes in the spaced-apart relationship relative to one another and hold the tubes in a spaced-apart relationship relative to the conduit.
3. The apparatus of Claim 2, wherein the potting material is further configured to restrict movement of the tubes relative to the conduit and/or restrict movement of the tubes relative to one another.
4. The apparatus of Claim 2, wherein the umbilical assembly further comprises a flexible member extending through at least a major portion of a length of the conduit, wherein the flexible member extends substantially along a centerline of the conduit, and wherein the flexible tubes surround the flexible member.

5. The apparatus of Claim 4, wherein the potting material is further configured to restrict movement of the tubes relative to the flexible member.

6. The apparatus of Claim 2, wherein the conduit is corrugated flexible conduit.

7. The apparatus of Claim 1, wherein the conduit and passageways are integrated as a flexible extrusion with an outer wall and internal elongate channels that define the spaced-apart passageways.

8. The apparatus of Claim 1, wherein each chamber is a flexible translucent or transparent fluid chamber, the apparatus further comprising at least one chamber holder pivotably mounted to the front side of the rotor, wherein each chamber holder is configured to releasably enclose a respective chamber.

9. The apparatus of Claim 8, wherein each chamber holder includes a window to allow visual access to the enclosed chamber.

10. The apparatus of Claim 2, wherein each chamber comprises a substantially conical body portion with a flange extending about at least a portion of a perimeter of the conical body portion, the flange including an inlet fluid path and an outlet fluid path, and wherein the first tube connects with the flange inlet fluid path of a respective chamber and the second tube connects with the flange outlet fluid path of the respective chamber.

11. The apparatus of Claim 10, wherein the flange inlet and outlet fluid paths are substantially parallel along a segment extending from a point at which the first and second tubes connect with the flange inlet and outlet fluid paths.

12. The apparatus of Claim 7, wherein each chamber comprises a substantially conical body portion and a flange extending about at least a portion of a perimeter of the conical body portion, the flange including an inlet fluid path and an outlet fluid path, and wherein the first elongate passageway of the conduit is in fluid communication with the flange inlet fluid path and the second elongate passageway of the conduit is in fluid communication with the flange outlet fluid path.



13. The apparatus of Claim 12, further comprising a first tube connecting the first passageway and the flange inlet fluid path and a second tube connecting the second passageway and the flange outlet fluid path, wherein the flange inlet and outlet paths are substantially parallel along a segment extending from a point at which the first and second tubes connect with the flange inlet and outlet paths.

14. The apparatus of Claim 13, further comprising a connector at each of the first and second passageways, one connector configured to connect the first tube with the first passageway and the other connector configured to connect the second tube with the second passageway.

15. The apparatus of Claim 1, wherein the drive mechanism comprises gears.

16. The apparatus of Claim 15, wherein the gears are at least partially enclosed by the drum.

17. The apparatus of Claim 1, wherein the rotor defines a substantially horizontal axis of rotation and the at least one chamber and the umbilical assembly rotate about the substantially horizontal axis.

18. The apparatus of Claim 1, wherein the curvilinear guide tube is configured to extend about the outer periphery of the rotor.

19. The apparatus of Claim 1, wherein the conduit includes proximal and distal opposite ends, wherein the conduit distal end connects to the rotor.

20. The apparatus of Claim 19, wherein the conduit distal end has a substantially hexagonally shaped coupling.

21. The apparatus of Claim 1, further comprising a plurality of spaced-apart flexible holders in the conduit configured to hold the passageways in the spaced-apart relationship.

22. The apparatus of any one of Claims 1-21, wherein the at least one chamber comprises a plurality of chambers mounted on the rotor in a spaced-apart relationship.

23. A disposable fluid path for use with a continuous flow centrifuge comprising a rotor having an outer periphery and front and rear opposite sides, the disposable fluid path comprising:

at least one chamber mounted on the rotor, each chamber having an inlet and an outlet;

a flexible conduit curving around the outer periphery of the rotor and connecting to the rotor;

first and second flexible tubes for each chamber extending through the conduit, wherein the first tube is in fluid communication with the inlet of a respective chamber and the second tube is in fluid communication with the outlet of the respective chamber; and

potting material within the conduit, the potting material configured to hold the tubes in a spaced-apart relationship.

24. The disposable fluid path of Claim 23, wherein the potting material is further configured to restrict movement of the tubes relative to the conduit and/or to restrict movement of the tubes relative to one another.

25. The disposable fluid path of Claim 23, further comprising a flexible member extending through the conduit, wherein the flexible member extends substantially along a centerline of the conduit, and wherein the flexible tubes surround the flexible member.

26. The disposable fluid path of Claim 25, wherein the potting material is further configured to restrict movement of the tubes relative to the flexible member.

27. The disposable fluid path of Claim 23, wherein the conduit includes proximal and distal opposite ends, wherein the conduit includes a coupling at the distal end, and wherein the coupling connects to the rotor.

28. The disposable fluid path of Claim 27, wherein the coupling has a substantially hexagonal shape.

29. An umbilical assembly for use with a continuous flow centrifuge having a rotor and at least one chamber having an inlet and an outlet attached to the rotor, the assembly comprising:

a curvilinear guide tube connecting to a drum at the rear side of the rotor;

a flexible conduit residing in the tube;

first and second flexible tubes for each chamber extending through at least a major portion of a length of the conduit, wherein the first tube is in fluid communication with the inlet of a respective chamber and the second tube is in fluid communication with the outlet of the respective chamber; and

potting material within the conduit, the potting material configured to hold the tubes in a spaced-apart relationship.

30. The umbilical assembly of Claim 29, wherein the potting material is further configured to restrict movement of the tubes relative to the conduit and/or restrict movement of the tubes relative to one another.

31. The umbilical assembly of Claim 29, further comprising a flexible member extending through the conduit, wherein the flexible member extends substantially along a centerline of the conduit, and wherein the flexible tubes surround the flexible member.

32. The umbilical assembly of Claim 31, wherein the potting material is further configured to restrict movement of the tubes relative to the flexible member.

33. An umbilical assembly for use with a continuous flow centrifuge having a rotor and at least one chamber attached to the rotor, the assembly comprising a flexible extrusion comprising first and second spaced-apart passageways therein for each chamber, wherein the first passageway is in fluid communication with an inlet of a respective chamber and the second passageway is in fluid communication with an outlet of the respective chamber.

34. A disposable fluid path for use with a continuous flow centrifuge having a rotor, the disposable fluid path comprising:

a first disposable section including:

at least one chamber configured to be held on the rotor, wherein each chamber has an inlet and an outlet; and

first and second tubes for each chamber, wherein the first tube is configured to be in fluid communication with the inlet of a respective chamber and the second tube is configured to be in fluid communication with the outlet of the respective chamber; and

a second disposable section including:

tubing in fluid communication with at least one container, wherein the tubing is configured pass through at least one valve.

35. The disposable fluid path of Claim 34, wherein the first disposable section includes return tubing in fluid communication with the at least one container.

36. The disposable fluid path of Claim 34, wherein the second disposable section includes return tubing in fluid communication with the at least one container.

37. The disposable fluid path of Claim 34, wherein the first and second disposable sections are configured to be connected using a sterile tube welding process.

38. The disposable fluid path of Claim 34, wherein each chamber comprises a flexible translucent or transparent fluid chamber, wherein the chamber comprises a substantially conical body portion, the chamber including a flange extending about at least a portion of a perimeter of the conical body portion, the flange including an inlet fluid path and an outlet fluid path, and wherein the first tube connects with the flange inlet fluid path of a respective chamber and the second tube connects with the flange outlet fluid path of the respective chamber.

39. The disposable fluid path of Claim 38, wherein the flange inlet and outlet fluid paths are substantially parallel along a segment extending from the point at which the first and second tubes connect with the flange inlet and outlet fluid paths.

40. A centrifugal fluid processing system, comprising:

a housing having an interior cavity with an access aperture extending from an external surface of the housing to the interior cavity;

a plurality of fluid chambers held in spaced apart relationship on a rotor in the interior cavity;

a flexible conduit holding a plurality of flexible tubes in a spaced-apart relationship therein, the flexible conduit extending from a location that is external to the housing through the access aperture and into the interior cavity, wherein the plurality of tubes includes first and second tubes for each chamber, wherein the first tube is in fluid communication with an inlet of a respective chamber and the second tube is in fluid communication with an outlet of the respective chamber, wherein the flexible conduit comprises a solid flexible material that substantially fills an internal volume of the conduit and substantially surrounds the flexible tubes, the solid flexible material configured to hold the flexible tubes in the spaced-apart relationship;

a substantially rigid curvilinear guide tube holding a portion of the flexible conduit in the interior cavity; and

a drive mechanism configured to rotate the guide tube at a first speed and the rotor and the fluid chambers at a second speed, wherein the second speed is about twice the first speed.

41. A centrifugal fluid processing system, comprising:

a housing having an interior cavity with an access aperture extending from an external surface of the housing to the interior cavity;

a plurality of fluid chambers held in spaced apart relationship on a rotor in the interior cavity;

a flexible conduit including a plurality of elongate spaced-apart passageways therein, the flexible conduit extending from a location that is external to the housing through the access aperture and into the interior cavity, wherein the plurality of passageways includes first and second passageways for each chamber, wherein the first passageway is in fluid communication with an inlet of a respective chamber and the second passageway is in fluid communication with an outlet of the respective chamber;

a substantially funnel-shaped support with an open center passage, the support having a shape that tapers outward as it extends further into the interior cavity, wherein the support surrounds the flexible conduit with a centerline of the funnel shaped support being in line with a centerline of the access aperture;

a substantially rigid curvilinear guide tube holding a portion of the flexible conduit in the interior cavity; and

a drive mechanism configured to rotate the guide tube at a first speed and the rotor and the fluid chambers at a second speed, wherein the second speed is about twice the first speed.

42. A centrifugal fluid processing system, comprising:

a housing having an interior cavity with an access aperture extending from an external surface of the housing to the interior cavity;

a plurality of flexible translucent or transparent fluid chambers having an inlet and an outlet held in spaced-apart relationship on a rotor in the interior cavity, wherein each chamber comprises a substantially conical body portion, each chamber including a flange extending about at least a portion of a perimeter of the conical body portion, the flange including an inlet fluid path and an outlet fluid path, wherein the flange inlet fluid path is in fluid communication with the inlet of the chamber and the flange outlet fluid path is in fluid communication with the outlet of the chamber;

a flexible conduit including a plurality of elongate spaced-apart passageways therein, the flexible conduit extending from a location that is external to the housing through the access aperture and into the interior cavity, wherein the plurality of passageways includes first and second passageways for each chamber, and wherein the first passageway is in fluid communication with the flange inlet fluid path of a respective chamber and the second passageway is in fluid communication with the flange outlet fluid path of the respective chamber;

a substantially rigid curvilinear guide tube holding a portion of the flexible conduit in the interior cavity;

a drive mechanism configured to rotate the guide tube at a first speed and the rotor and the fluid chambers at a second speed, wherein the second speed is about twice the first speed; and

a plurality of substantially rigid chamber holders in the interior cavity, each sized and configured to releasably hold a respective flexible chamber attached to the rotor.

43. A method of manipulating particles, comprising:

providing:

at least one chamber on a rotor having an outer periphery, each chamber having an inlet and an outlet;

a flexible conduit with first and second spaced-apart passageways therein for each chamber, wherein the first passageway is in fluid communication with the inlet of a respective chamber and the second passageway is in fluid communication with the outlet of the respective chamber;

a substantially rigid curvilinear guide tube holding a portion of the conduit therein and curving around the outer periphery of the rotor;

rotating the rotor and the at least one chamber at a first speed, thereby creating a centrifugal force field;

rotating the guide tube and conduit therein at a second speed, wherein the second speed is about one-half the first speed, thereby inhibiting the first and second passageways for each chamber from fully twisting;

flowing media and particles into a respective chamber using the first passageway, wherein a continuous flow of media and particles creates a fluid force that substantially opposes the centrifugal force field, thereby immobilizing at least some of the particles in a fluidized bed in the respective chamber; and

flowing media out of the respective chamber and through the second passageway.

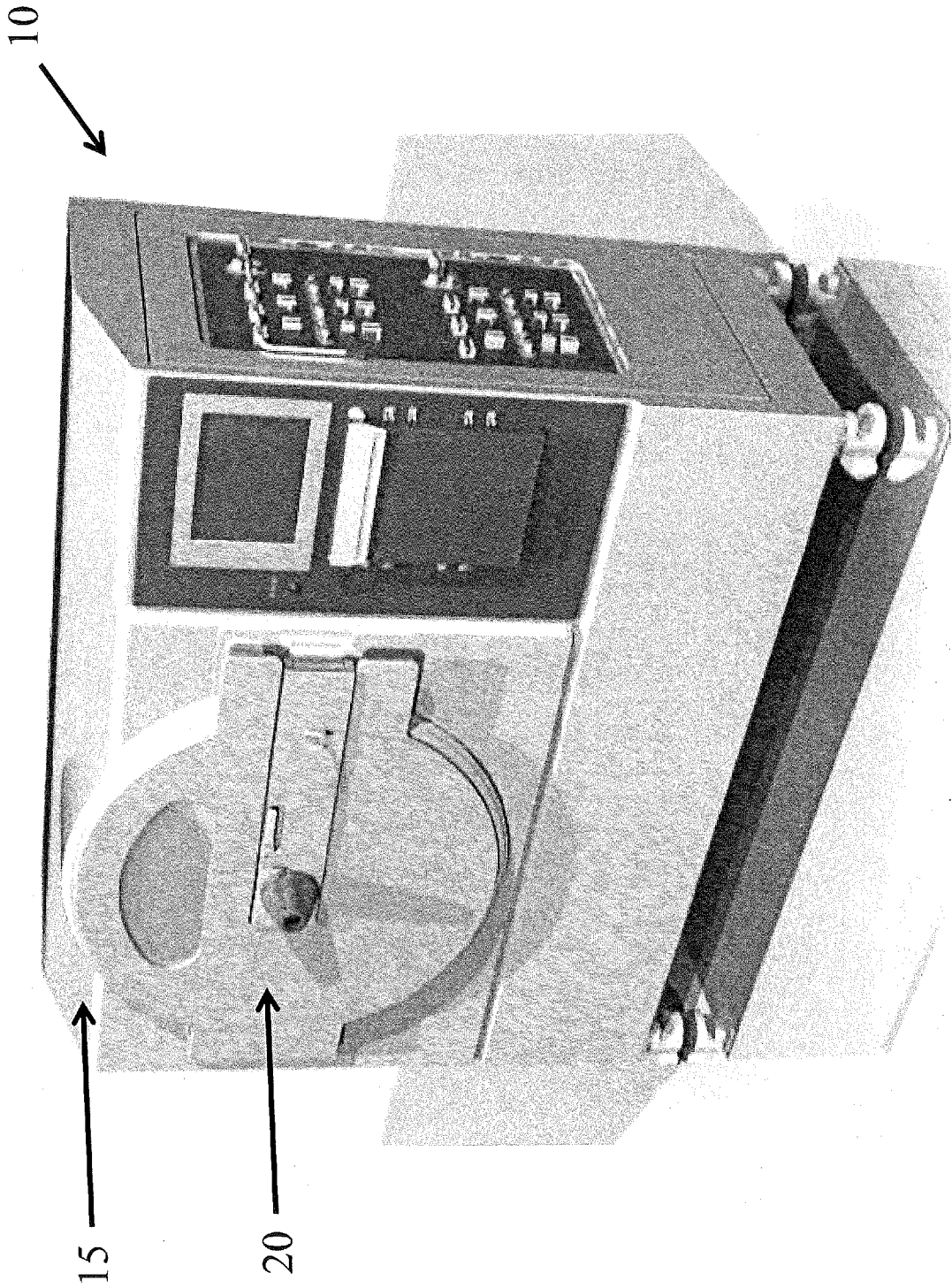

Figure 1



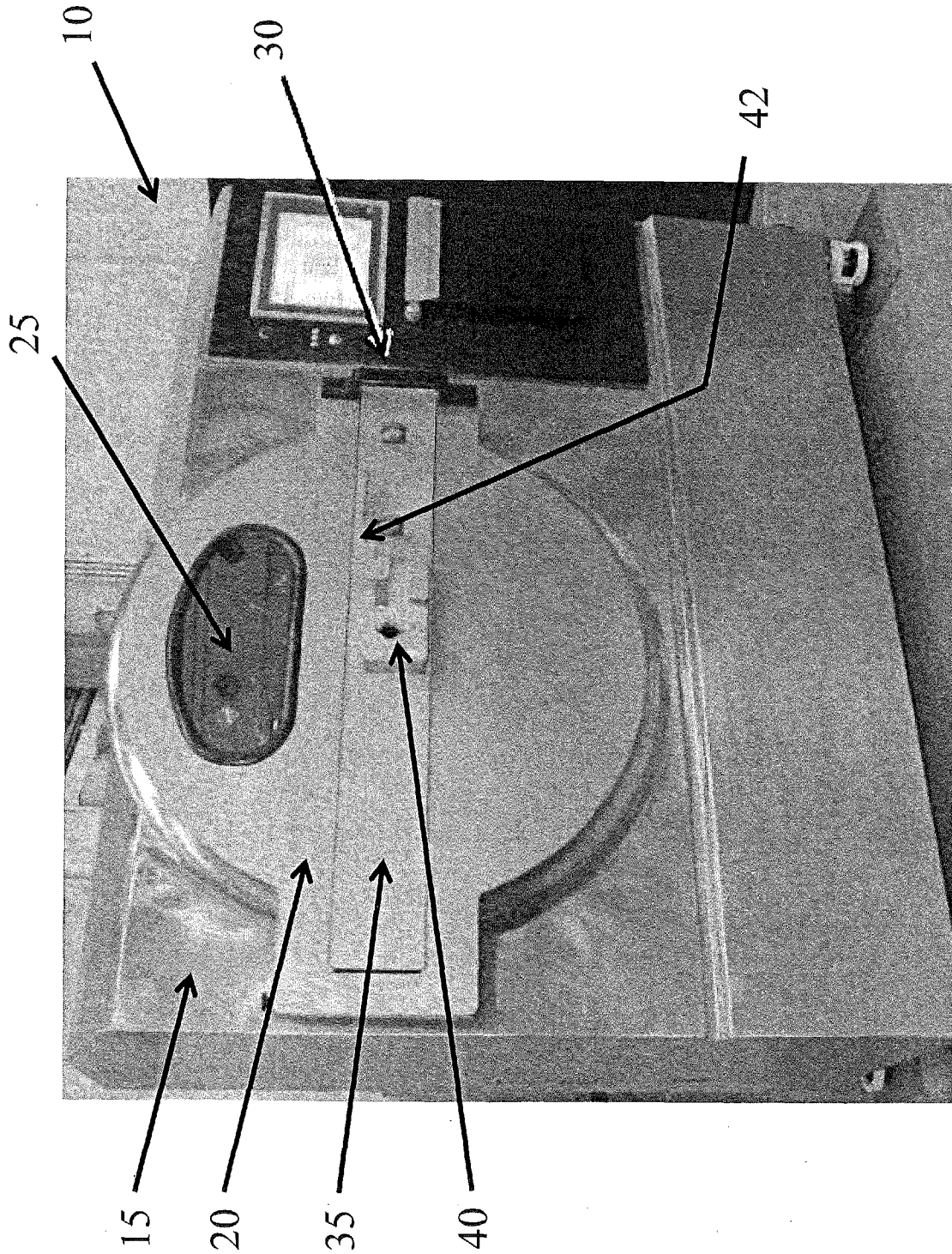

Figure 2

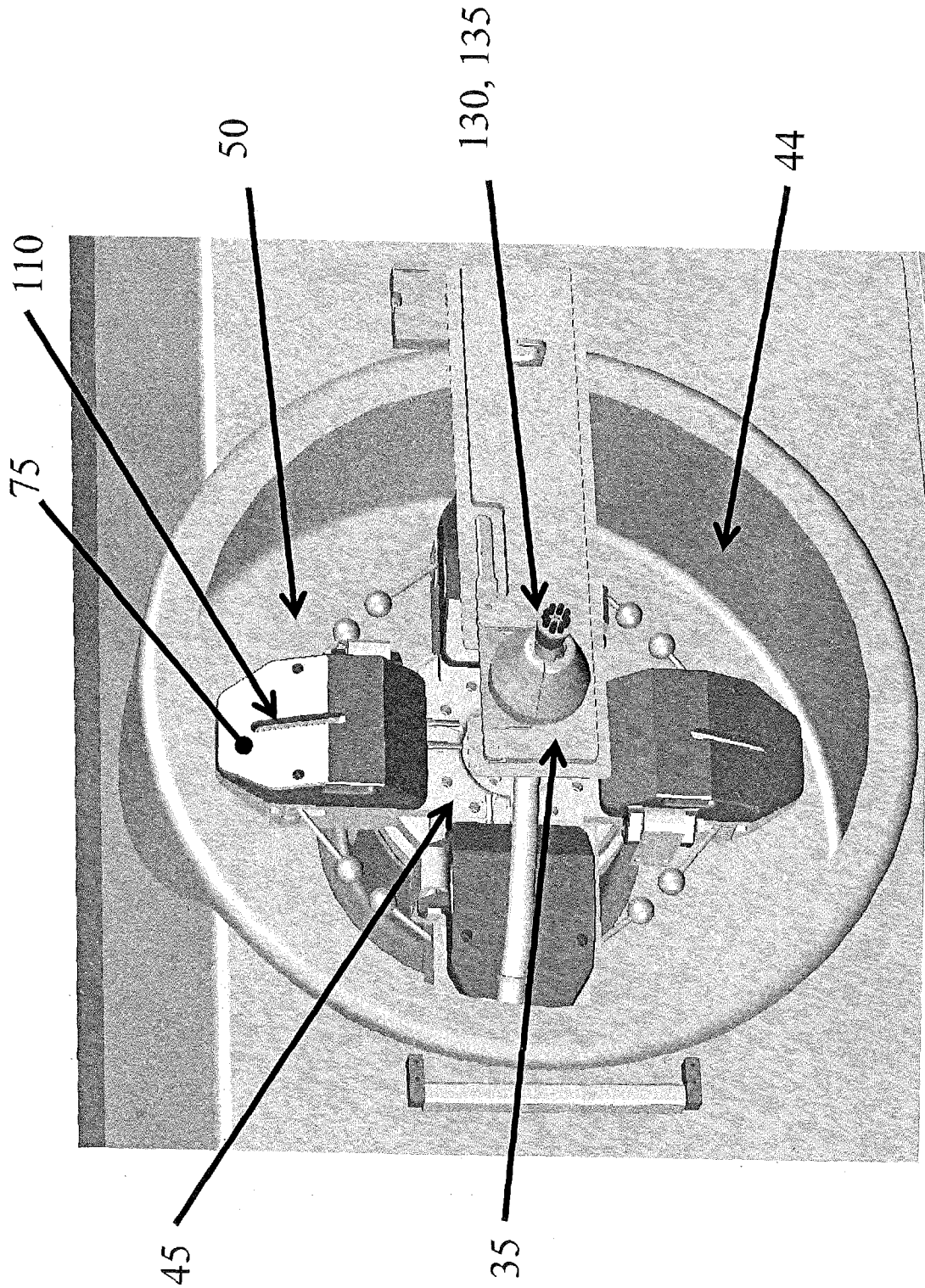

Figure 3

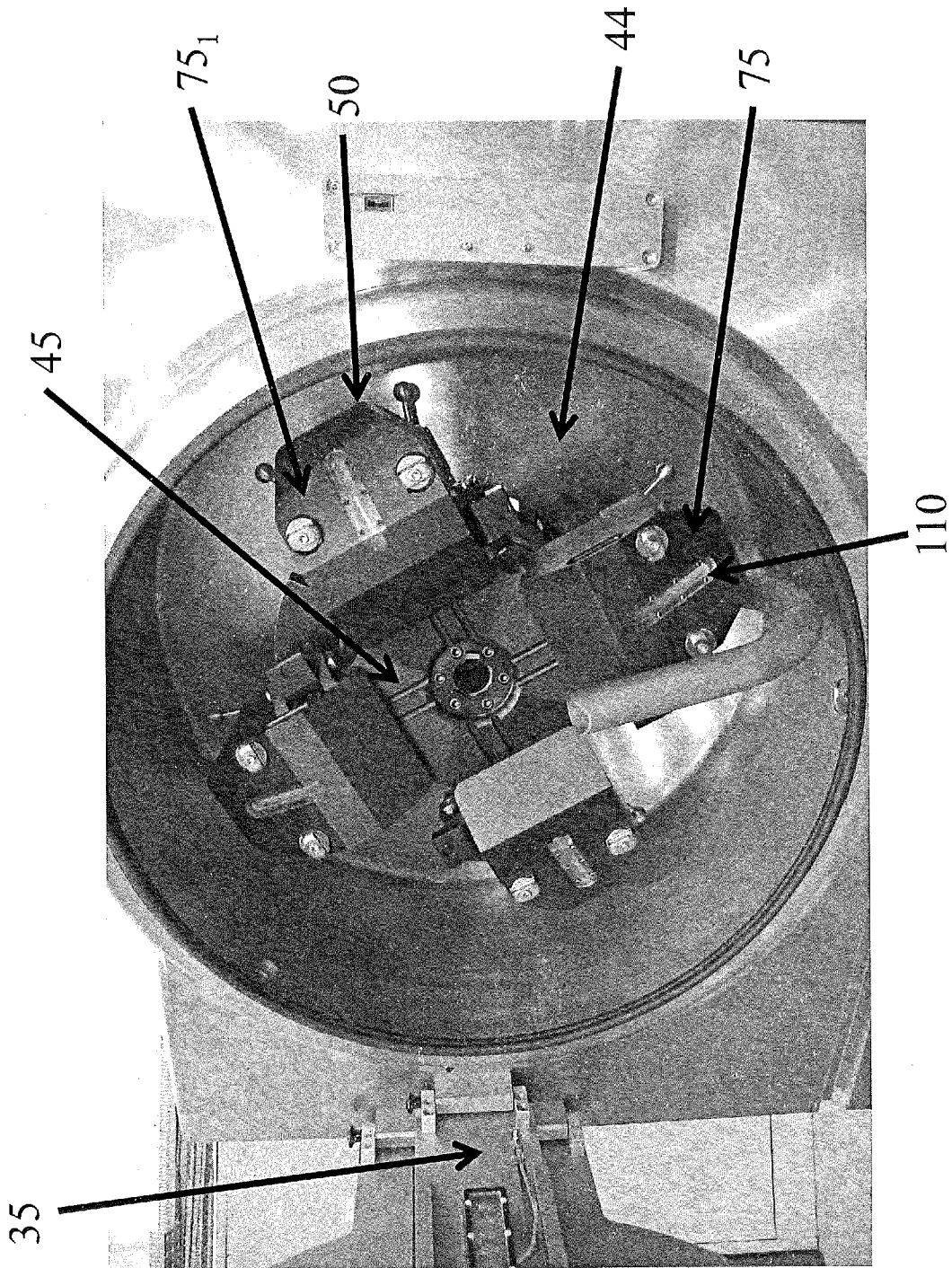

Figure 4

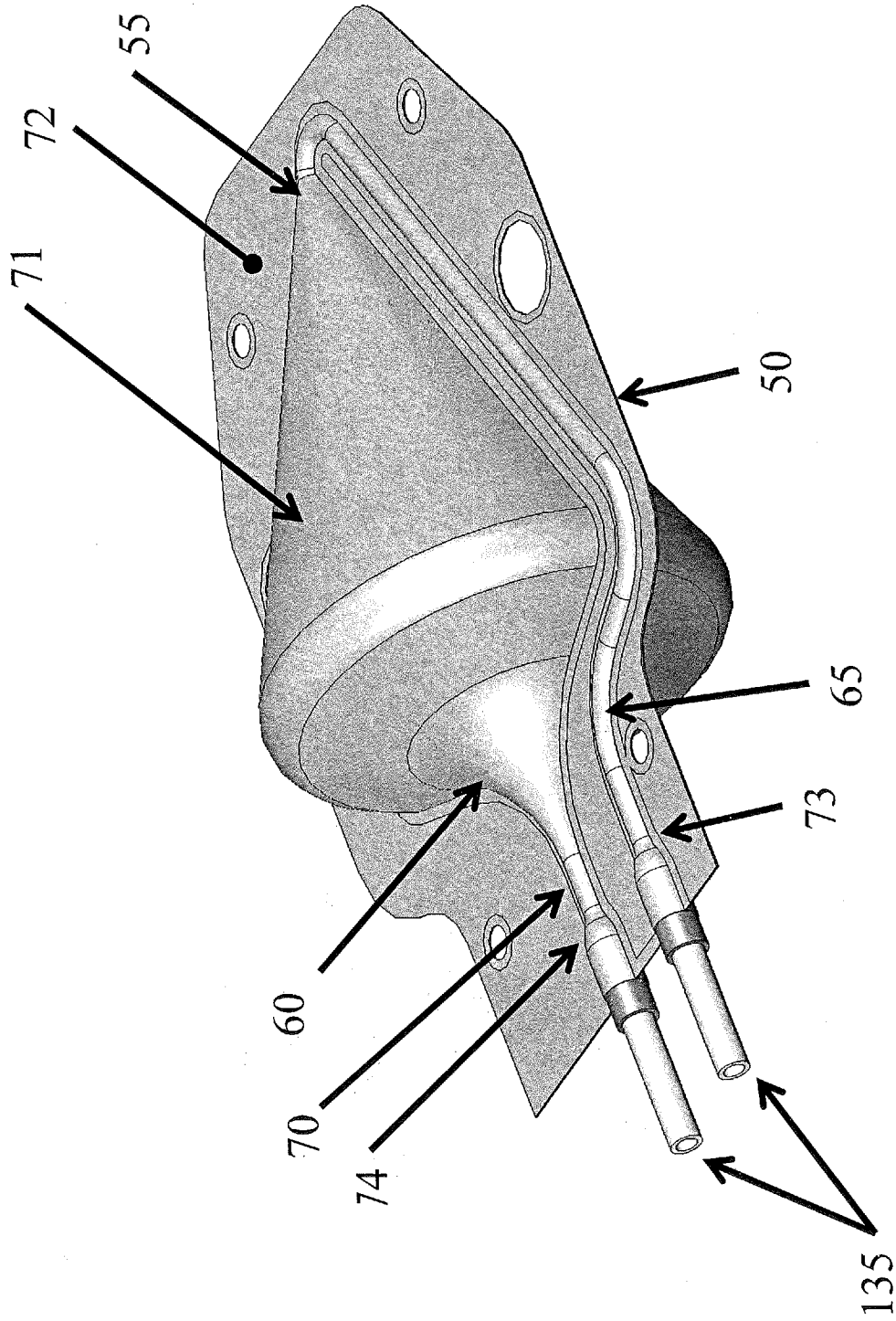

Figure 5A

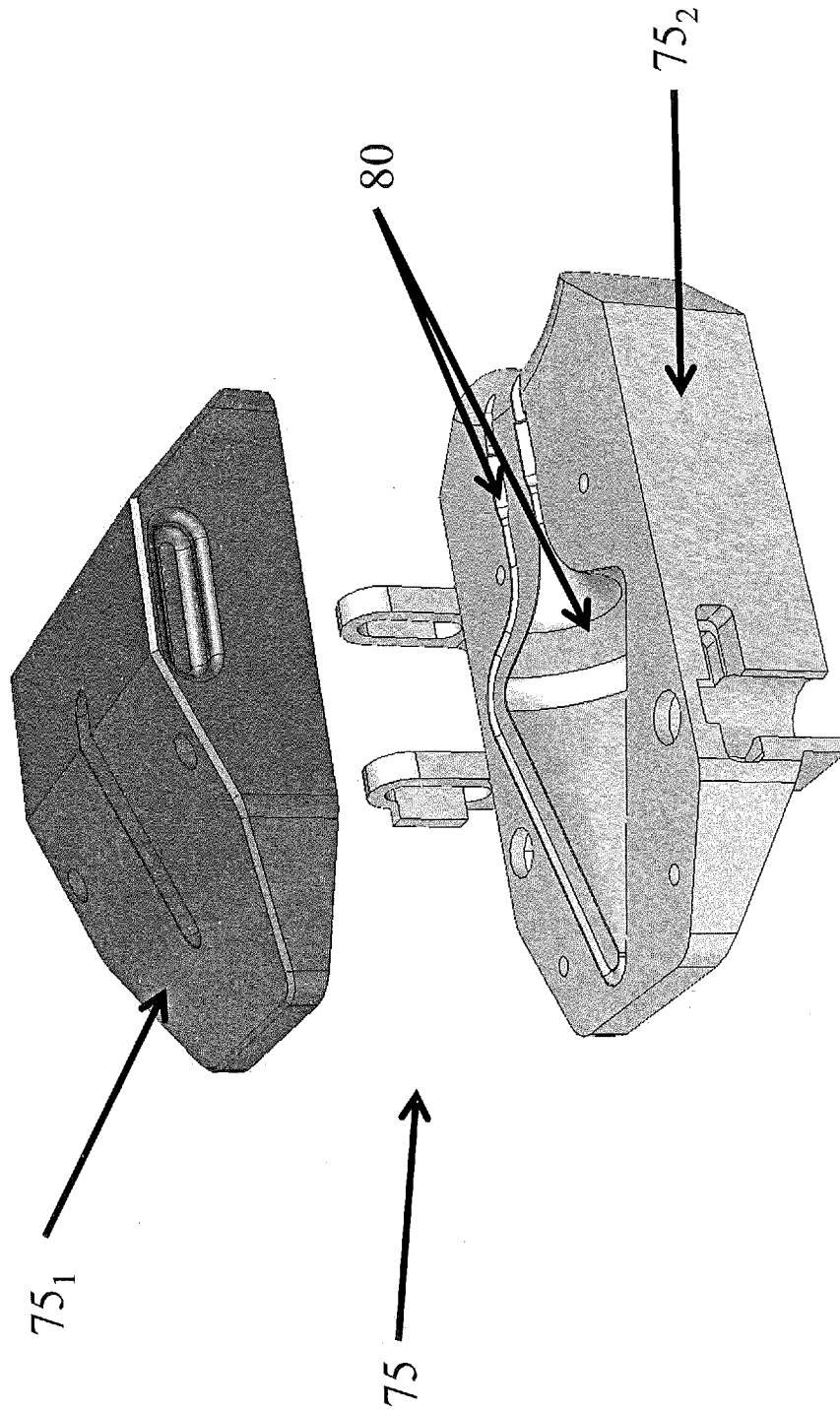

Figure 5B

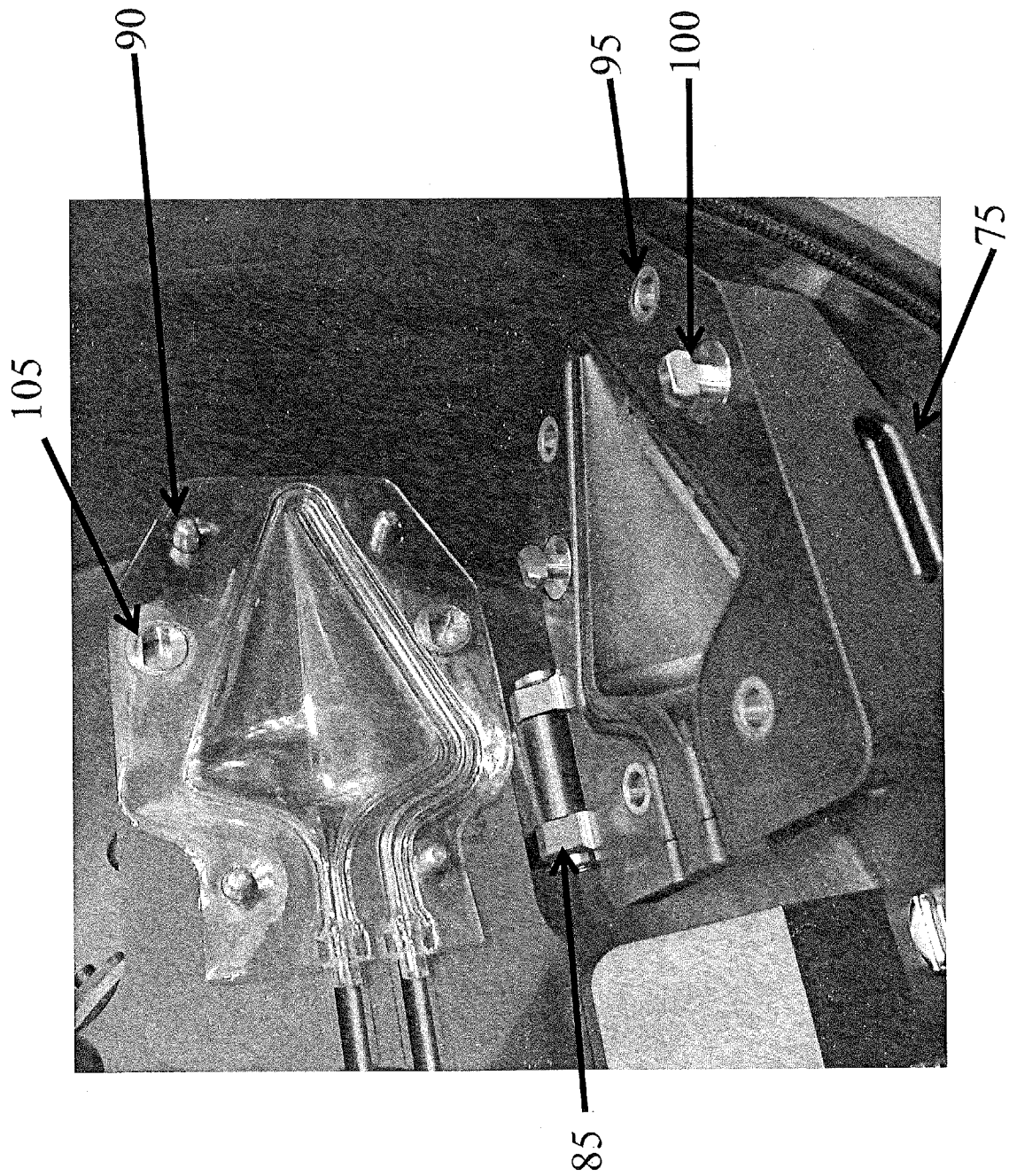

Figure 6

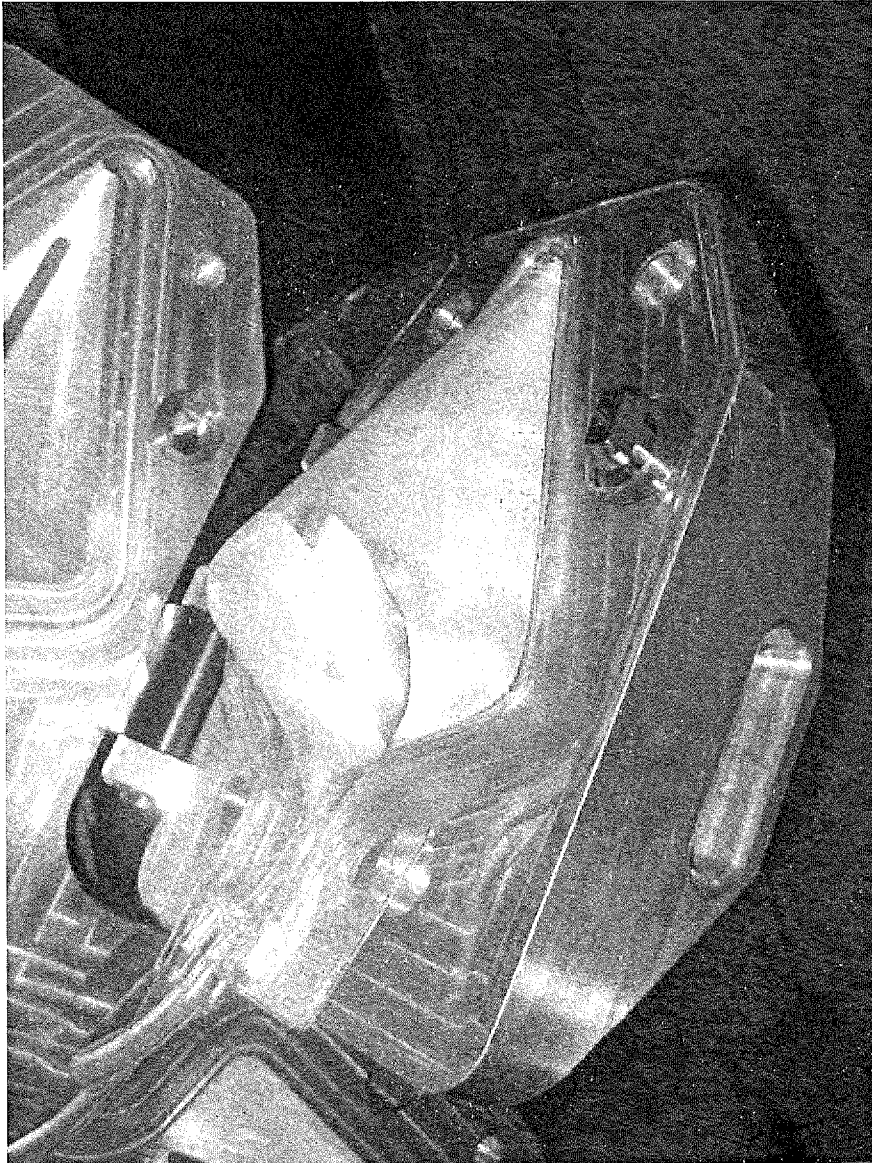

Figure 7

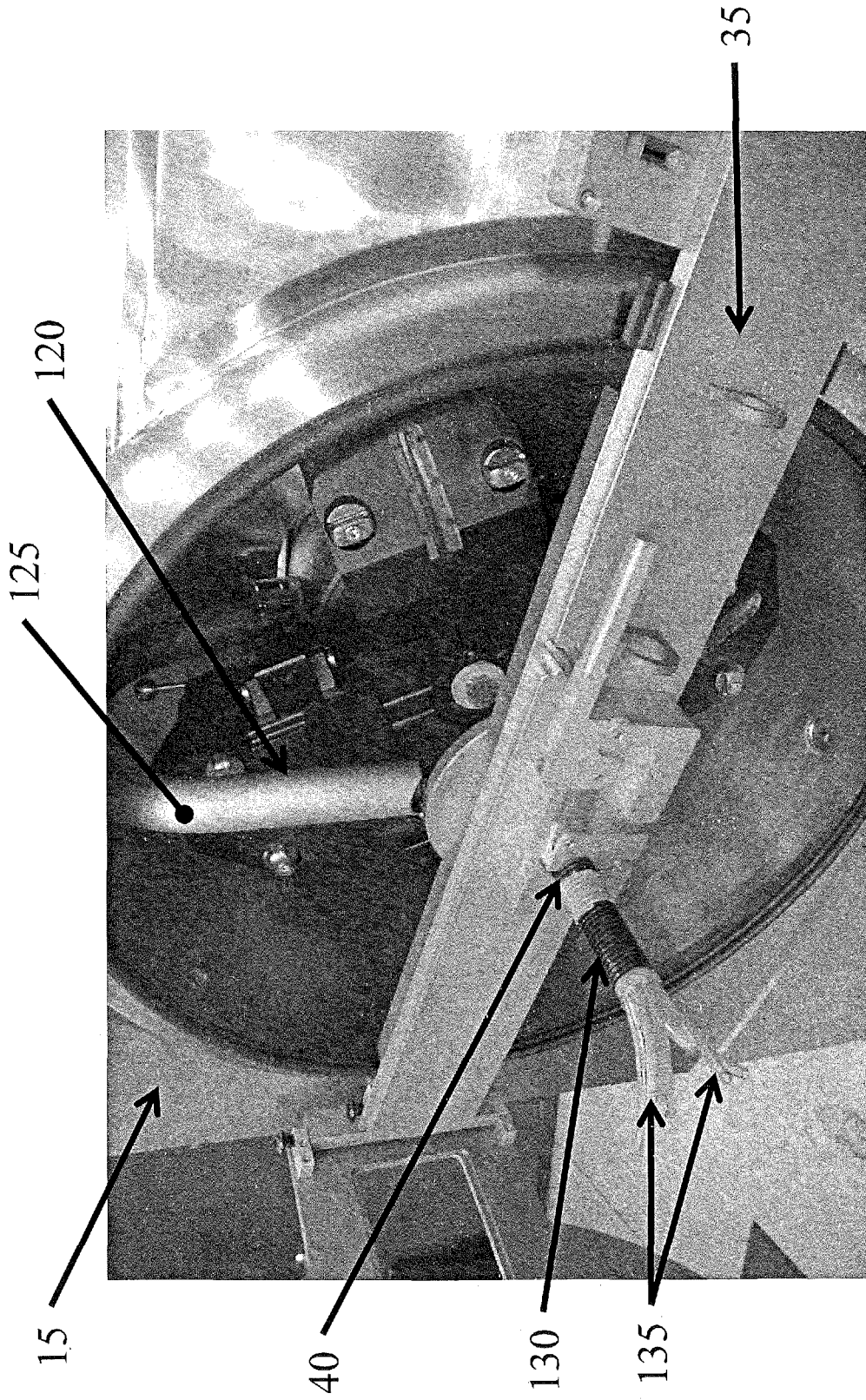

Figure 8



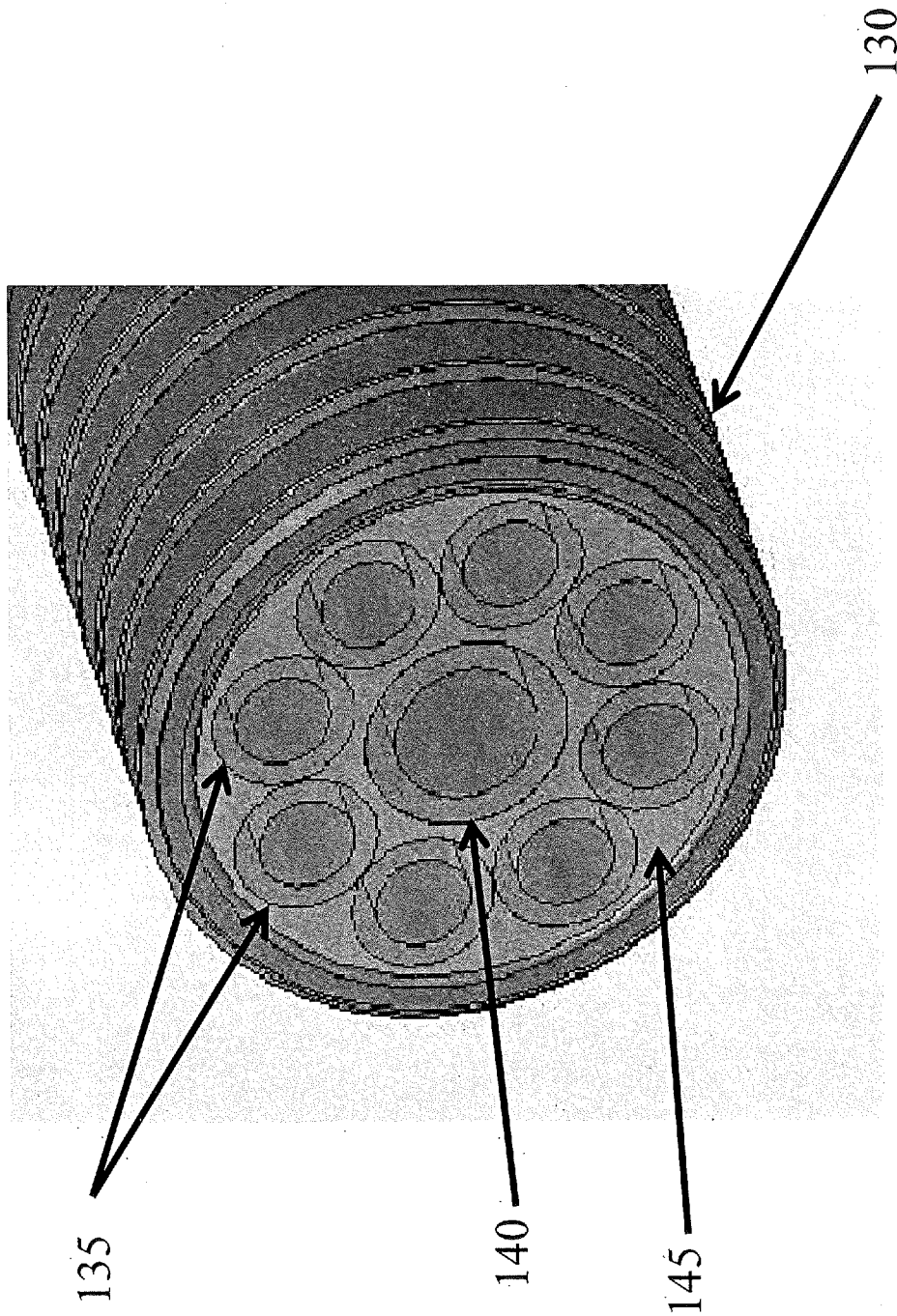

Figure 9A

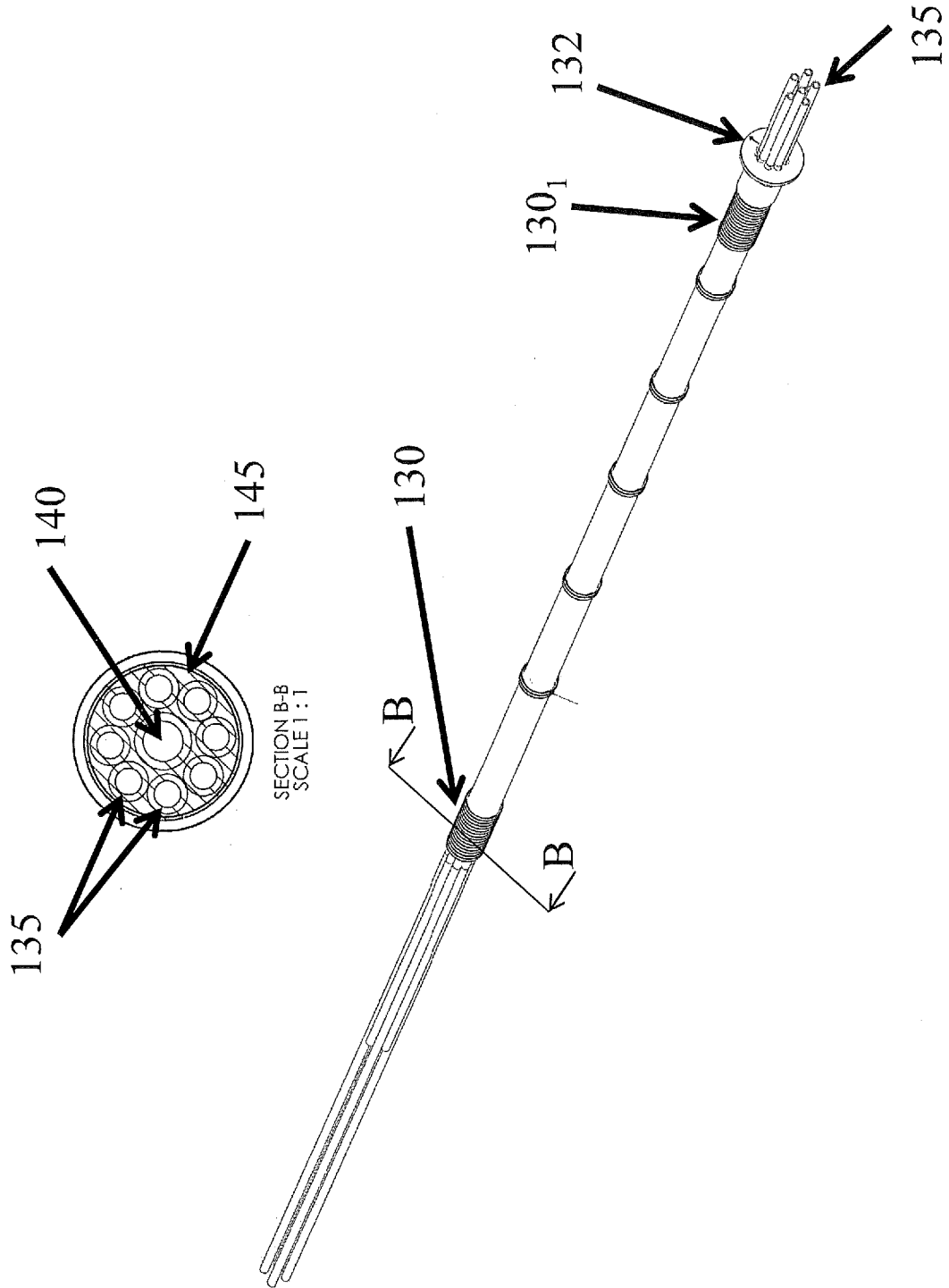

Figure 9B

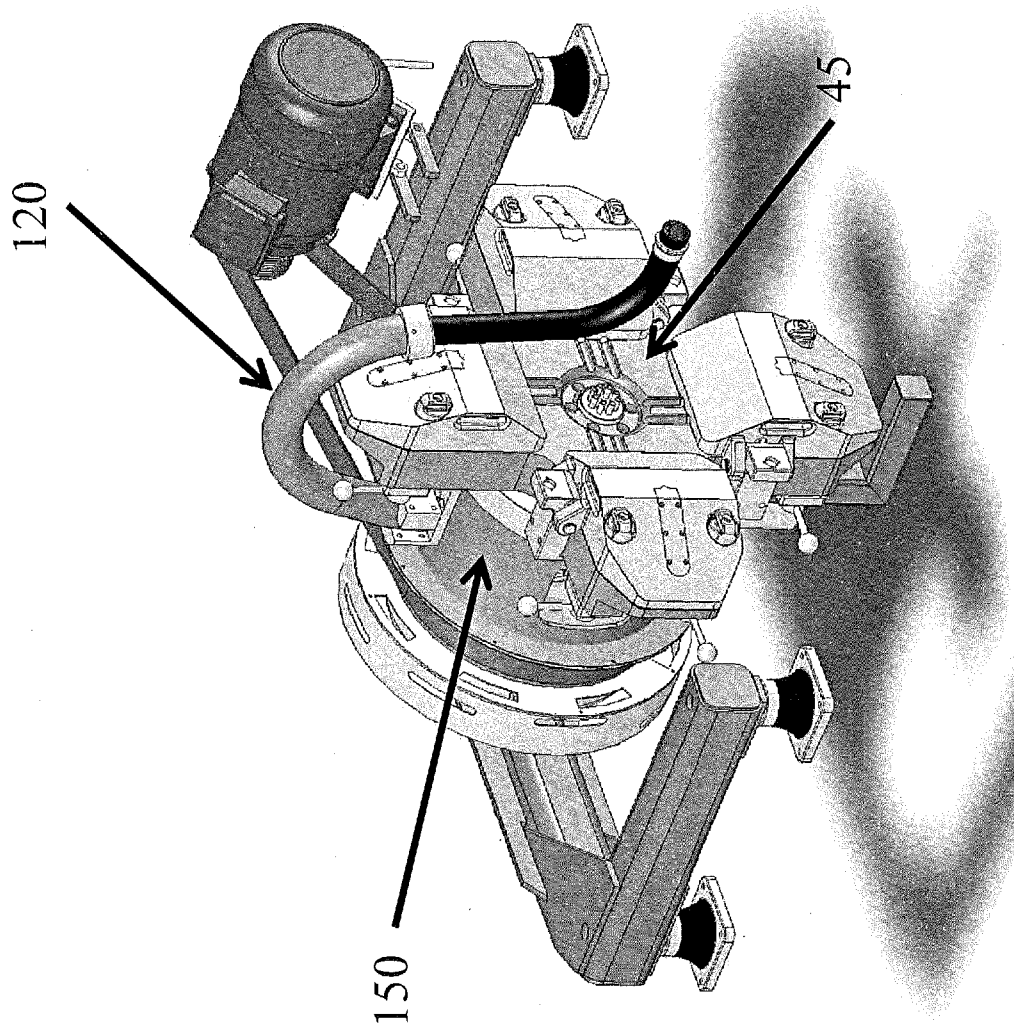

Figure 10

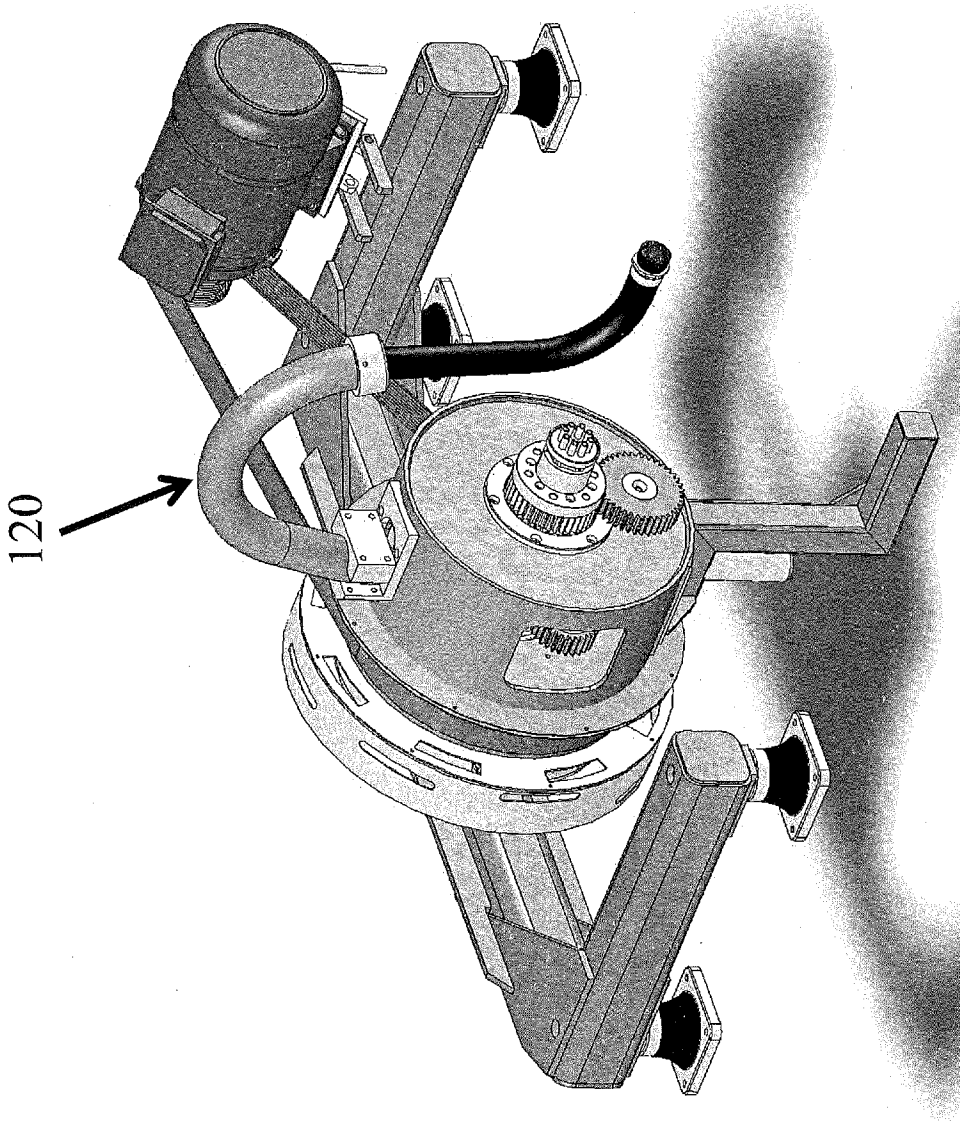

Figure 11

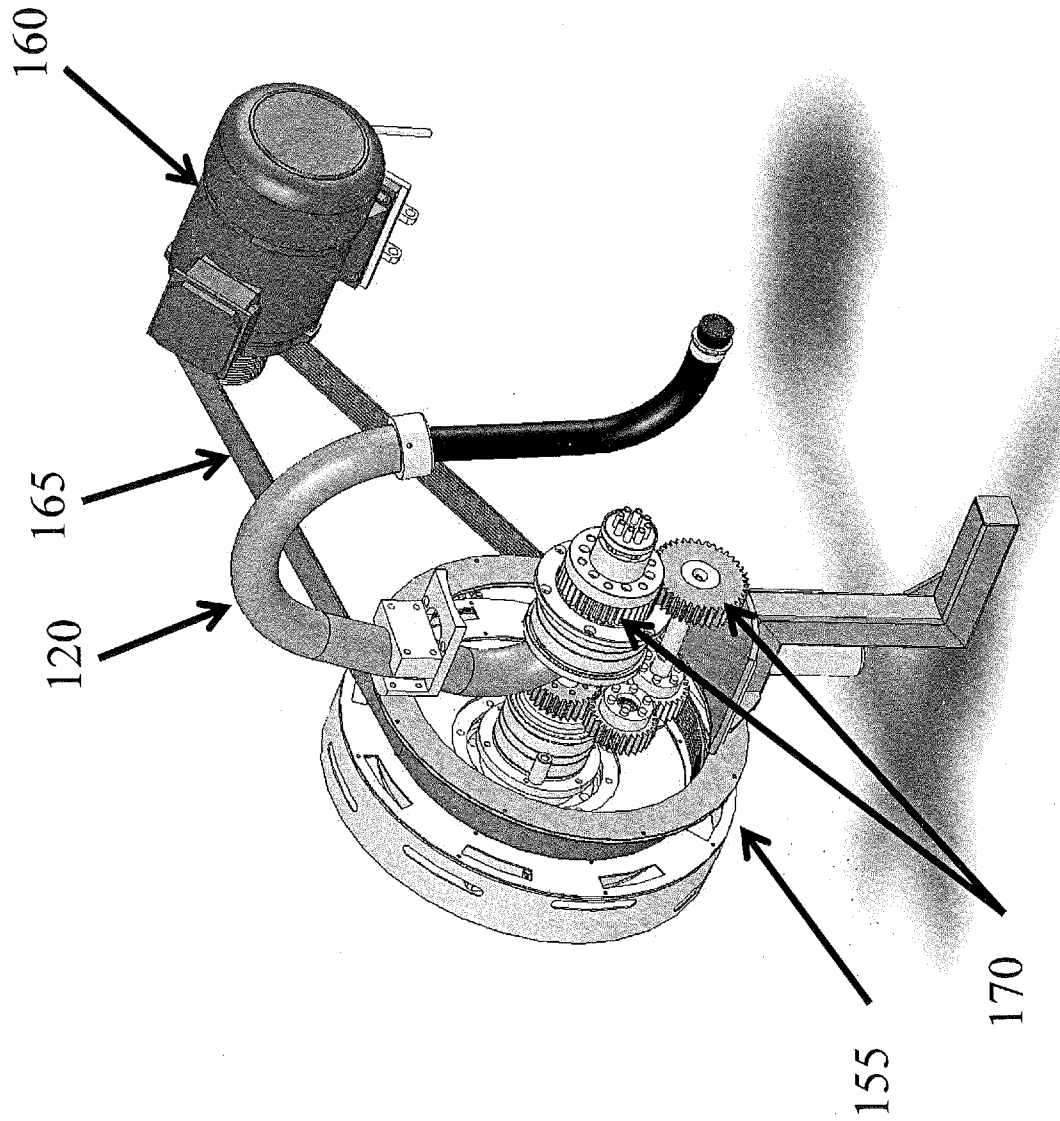

Figure 12

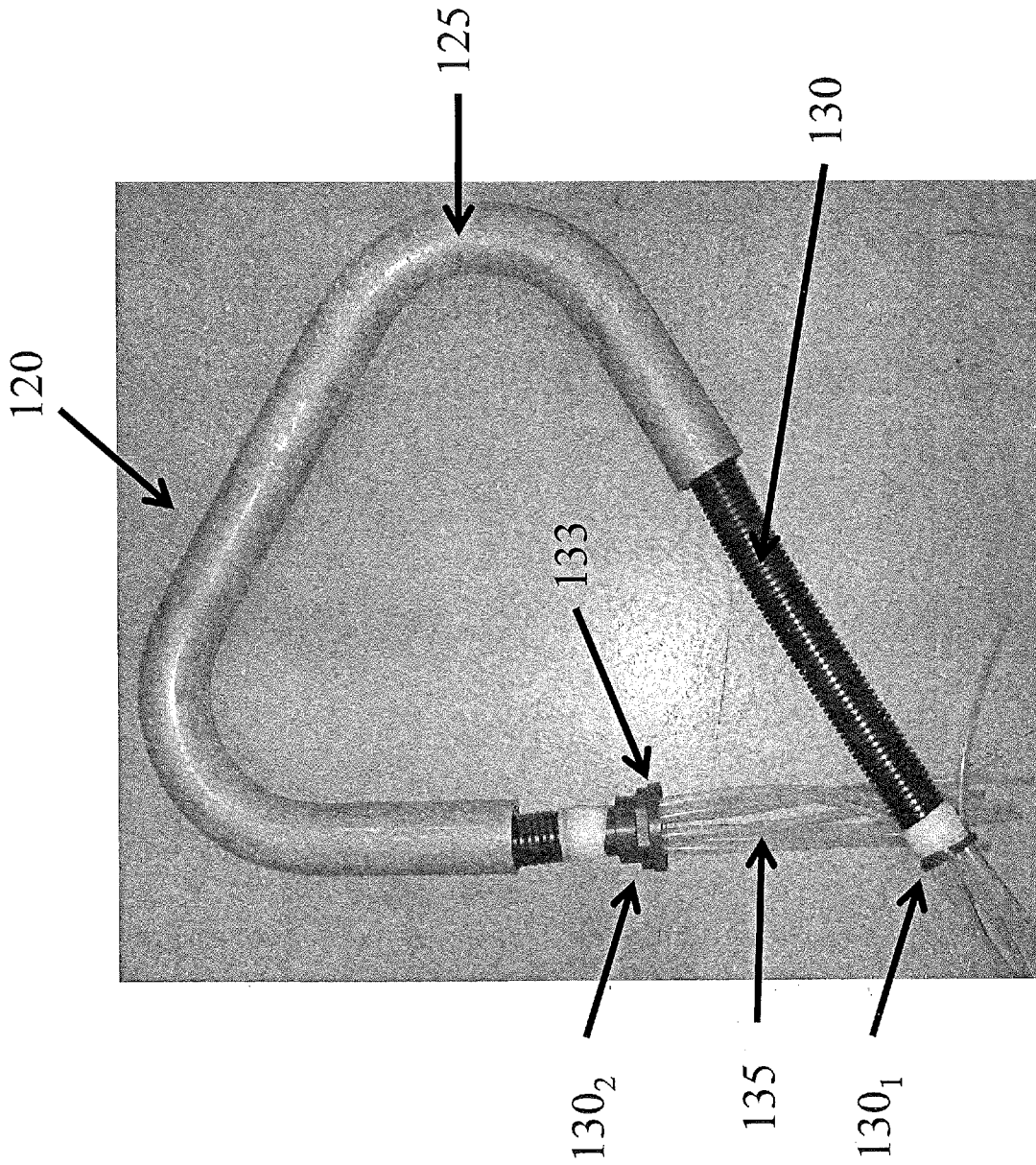

Figure 13

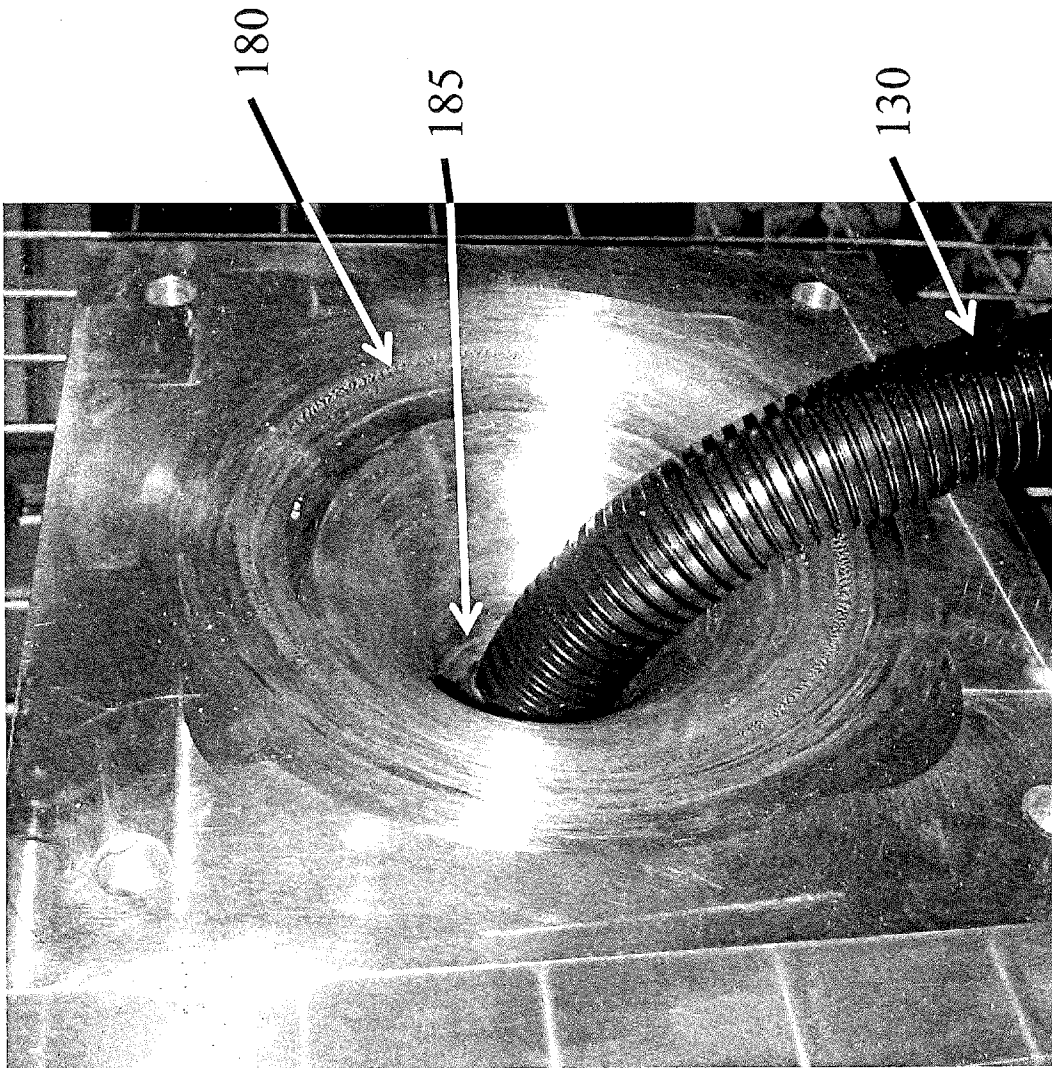

Figure 14A

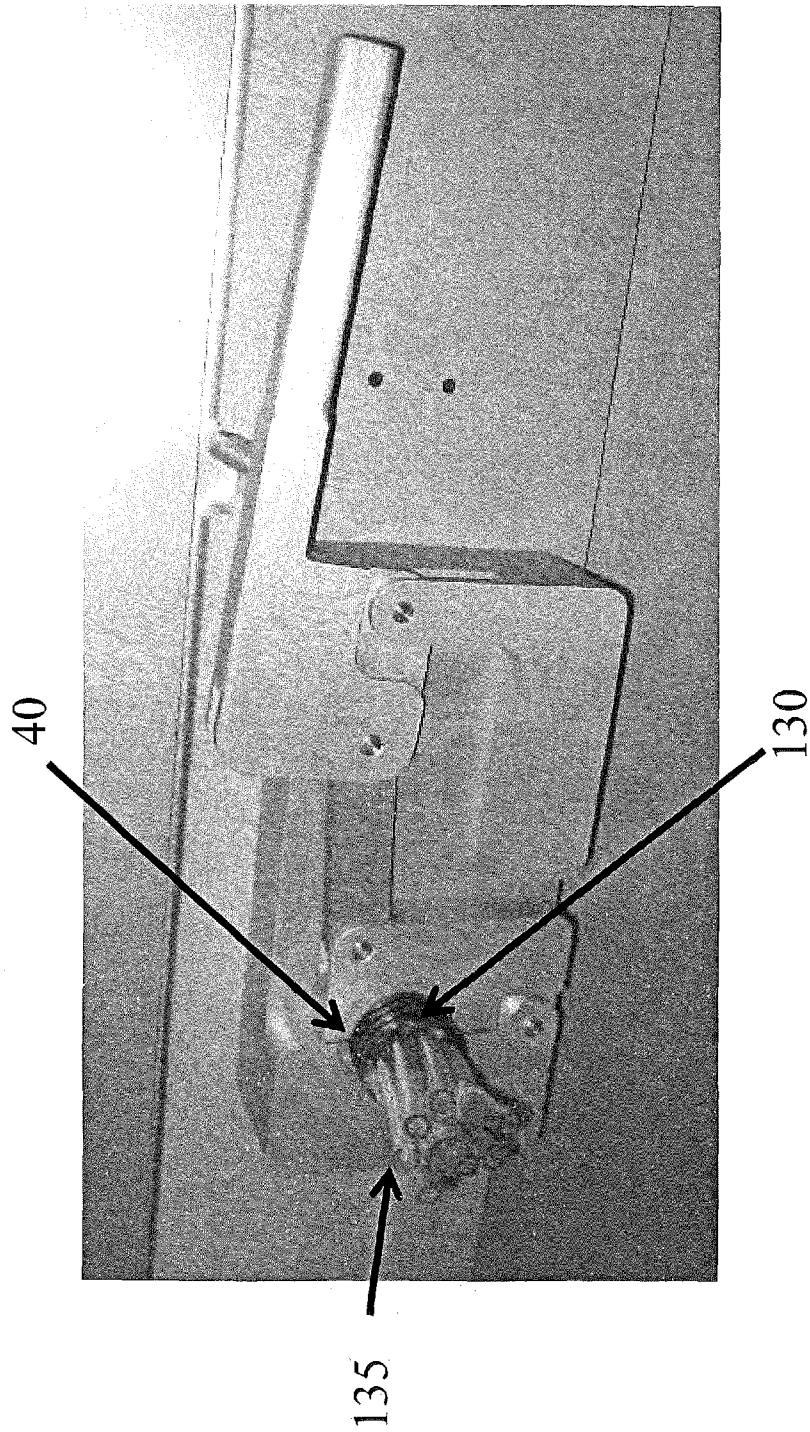

Figure 14B



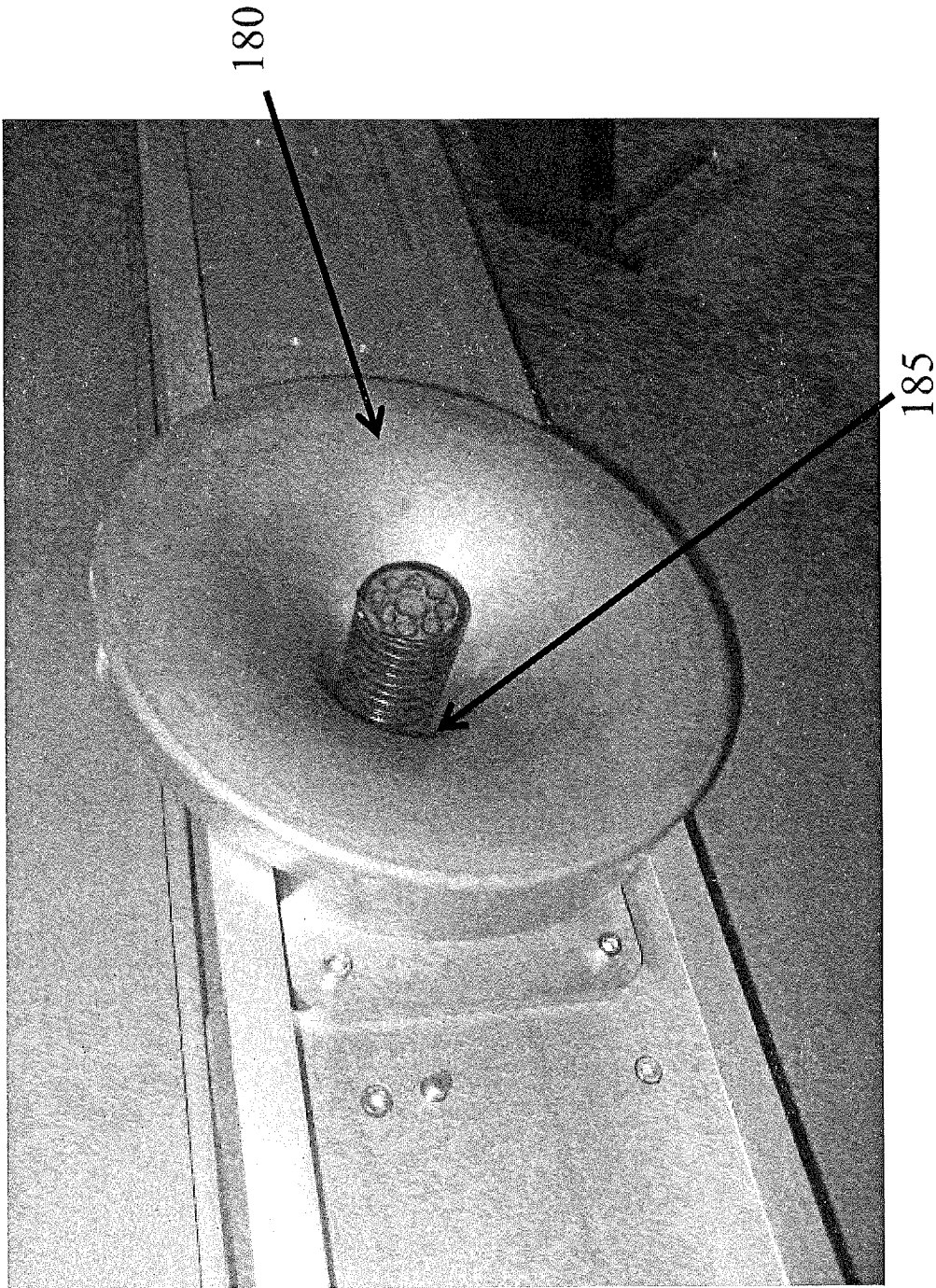

Figure 14C

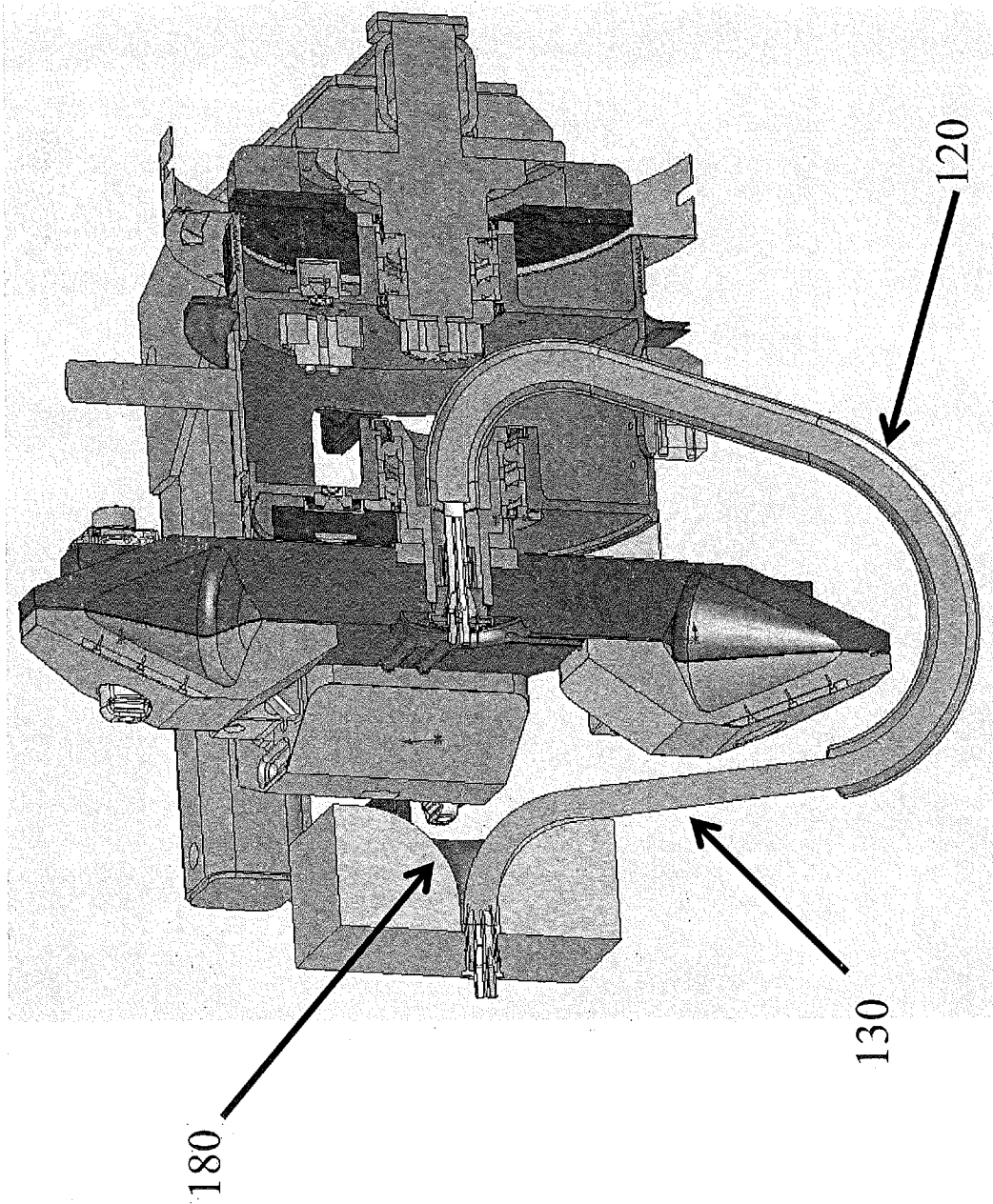

Figure 14D

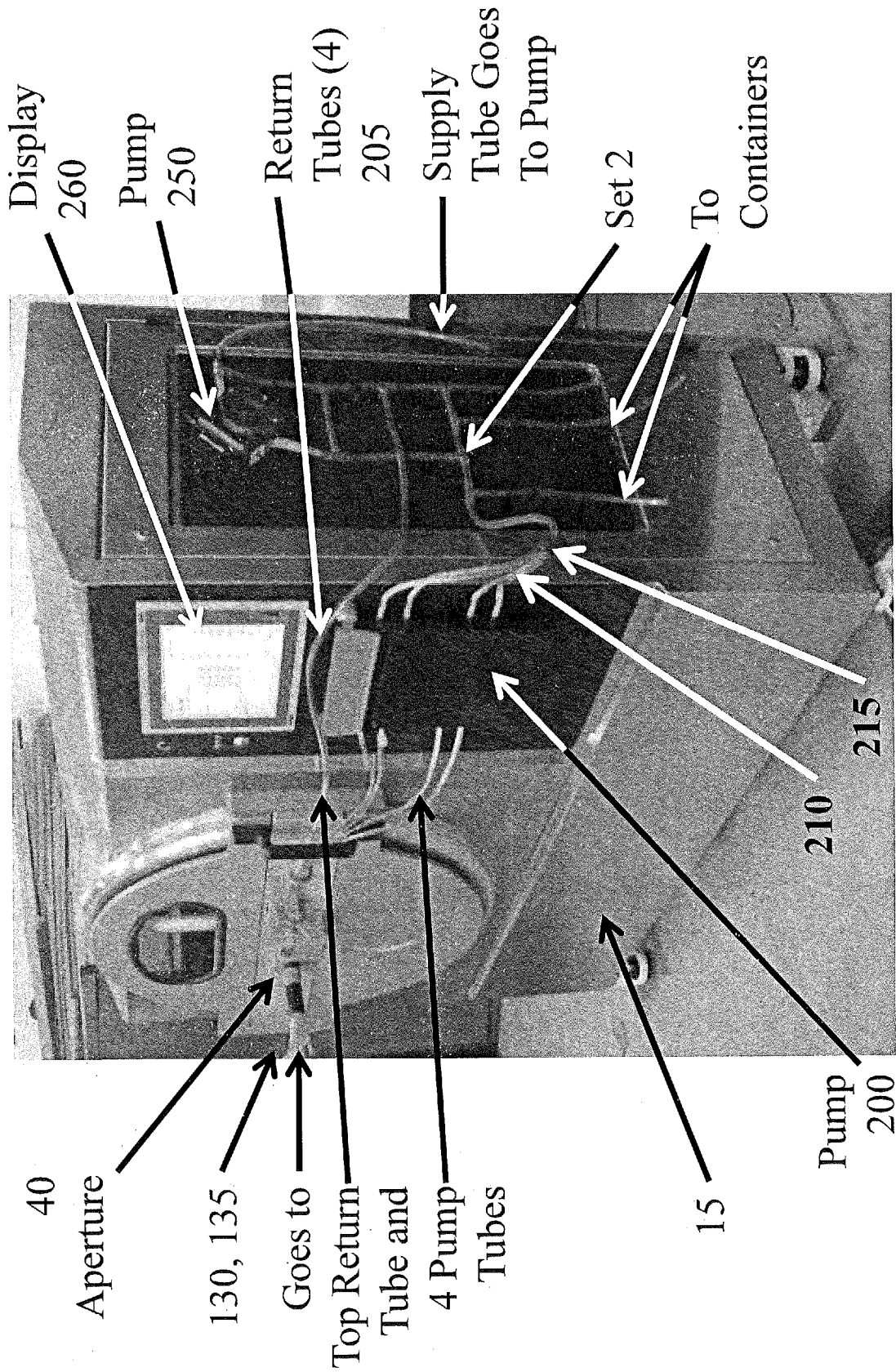

Figure 15

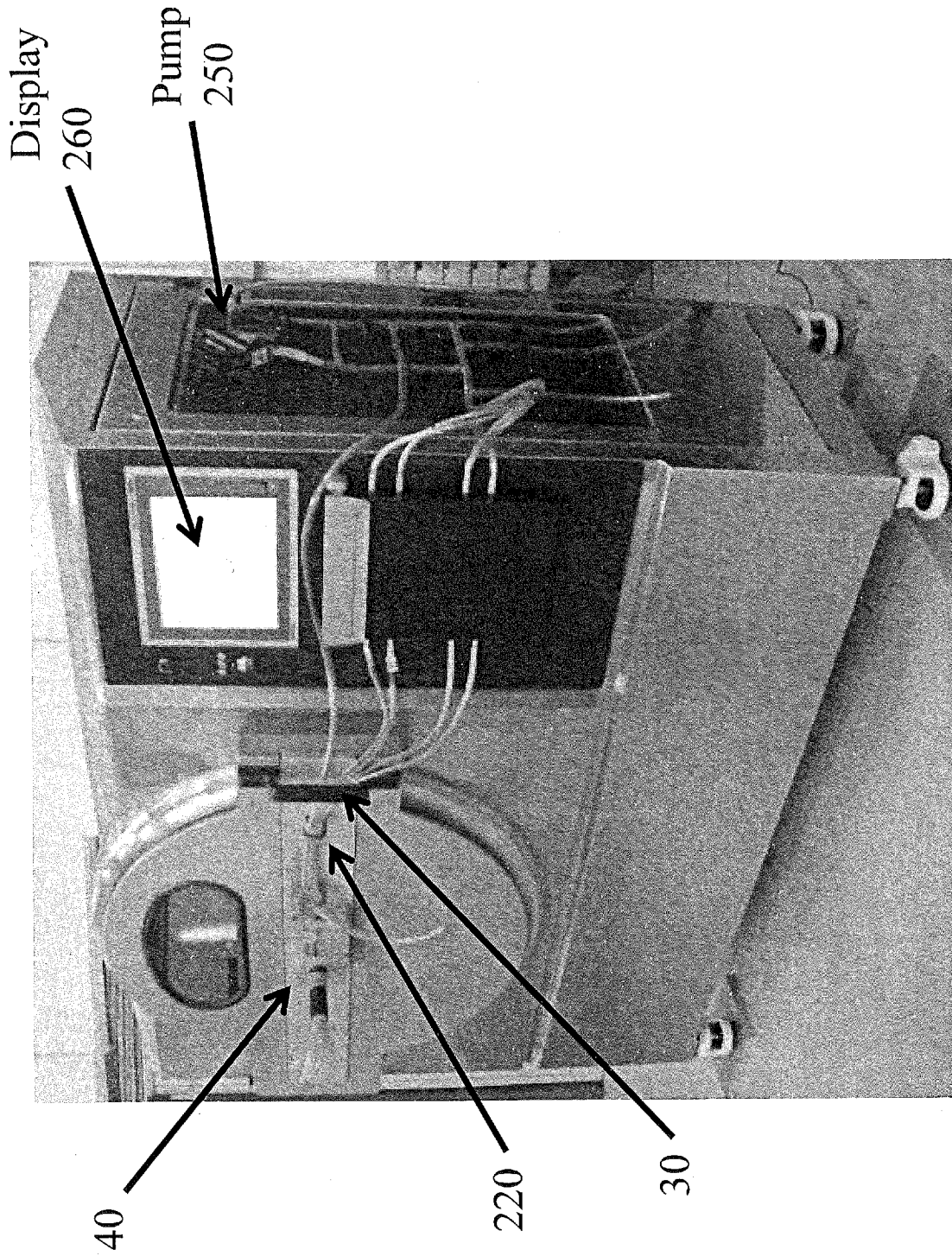

Figure 16

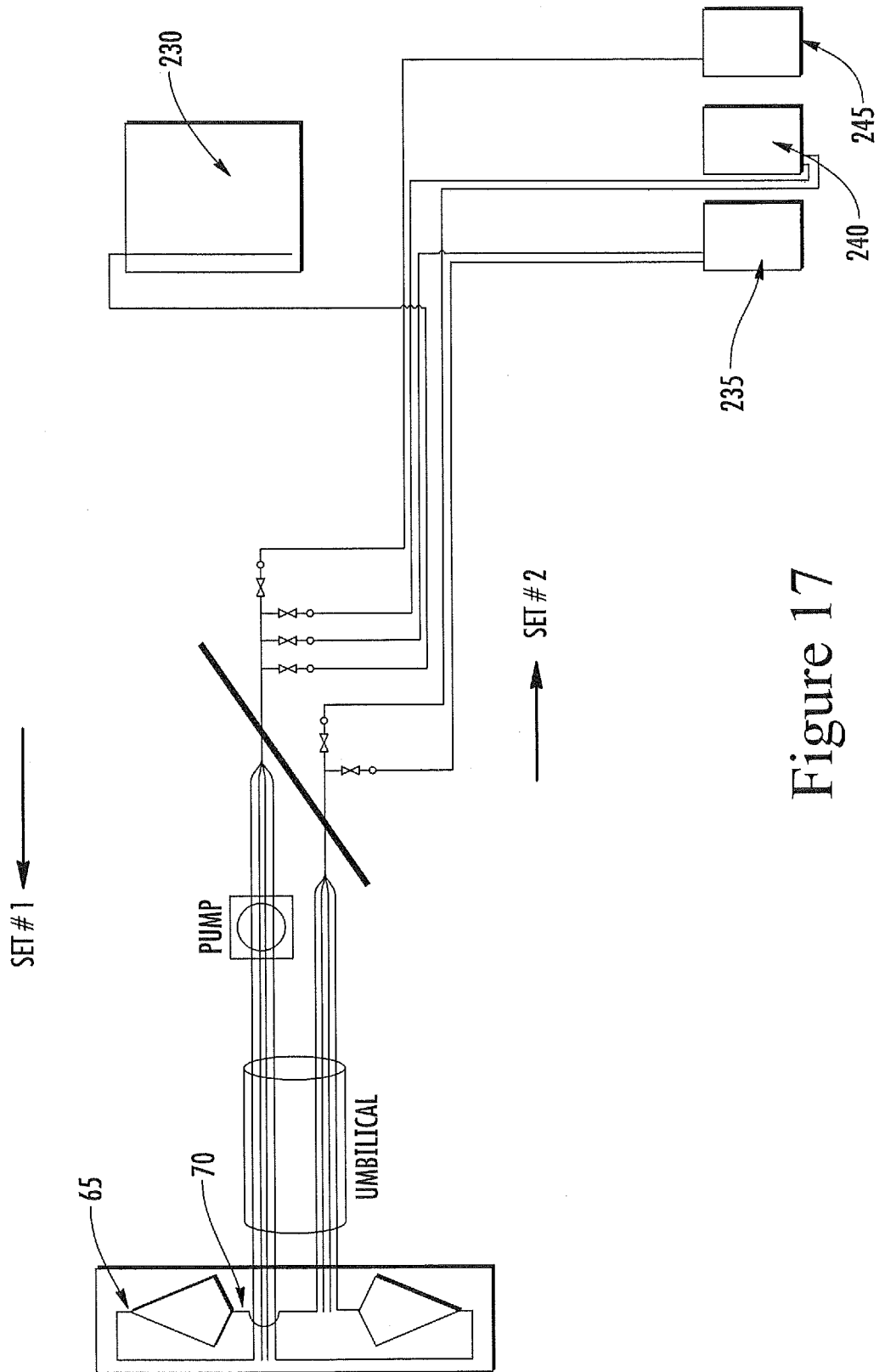



Figure 17

  
**KBI**

  
**Invetech**

Main  
Screen

**Manual Control**

CENTRIFUGE / PERISTALTIC PUMPS

	Speed	REV	Stop	FWD
Pump A	(ml/min)	▼	■	▲
Pump B	(ml/min)	▼	■	▲
Pump C	(ml/min)	▼	■	▲
Pump D	(ml/min)	▼	■	▲
Media Pump	(ml/min)	▼	■	▲
Centrifuge	(g)	▼	■	▲

PINCH VALVES

Open	PV1 (Open)	Close
Open	PV2 (Open)	Close
Open	PV3 (Open)	Close
Open	PV4 (Open)	Close
Open	PV5 (Open)	Close
Open	PV6 (Open)	Close
Open	PV7 (Open)	Close
Open	PV8 (Open)	Close
Open All		Close All

11:32:24 AM

BUBBLE SENSORS

Bubble Sensor 1: Air/uid	Bubble Sensor 3: Air/uid
Bubble Sensor 2: Air/uid	Bubble Sensor 4: Air/uid

\$\$\$\$\$

Figure 18



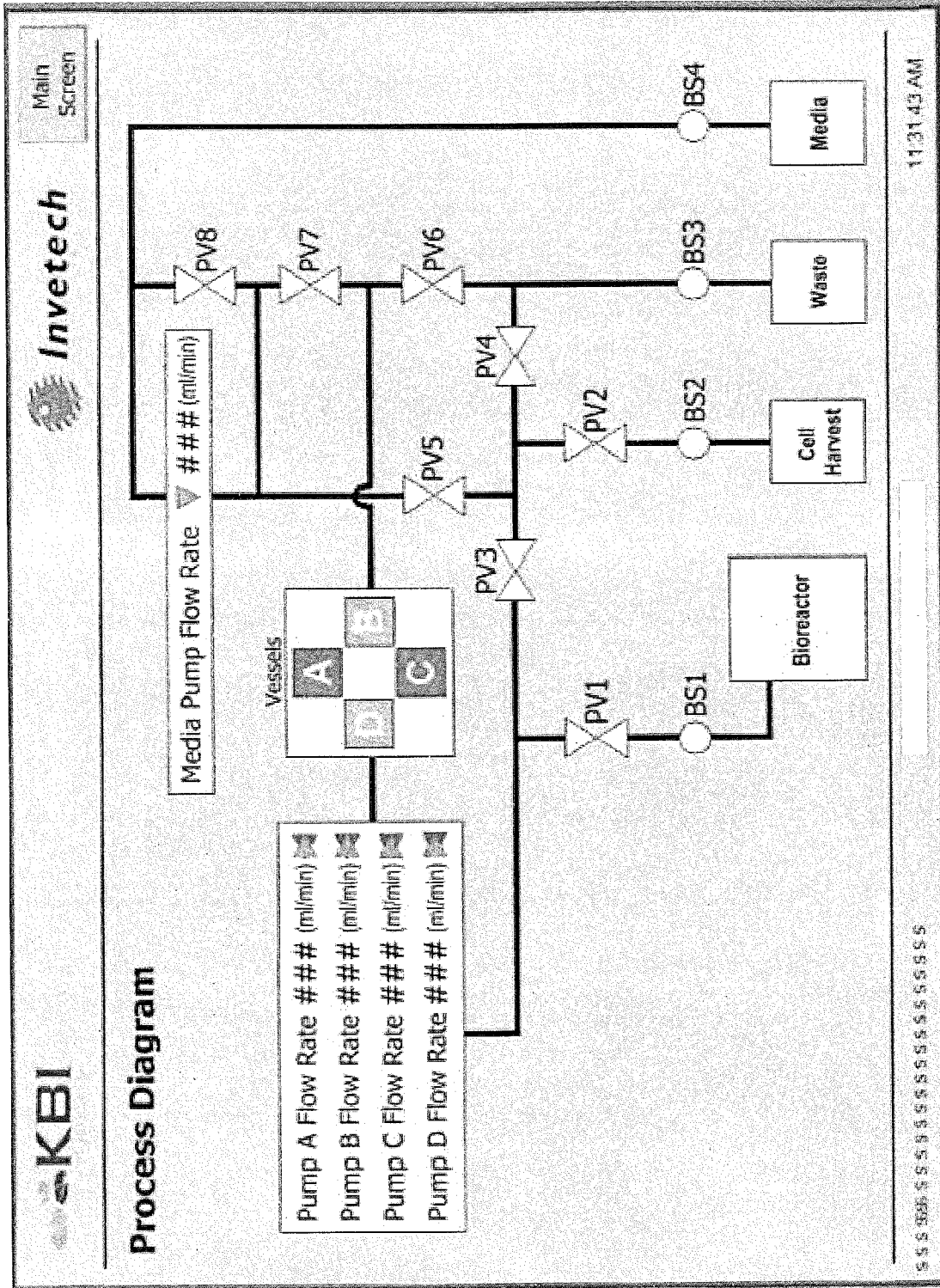

Figure 20



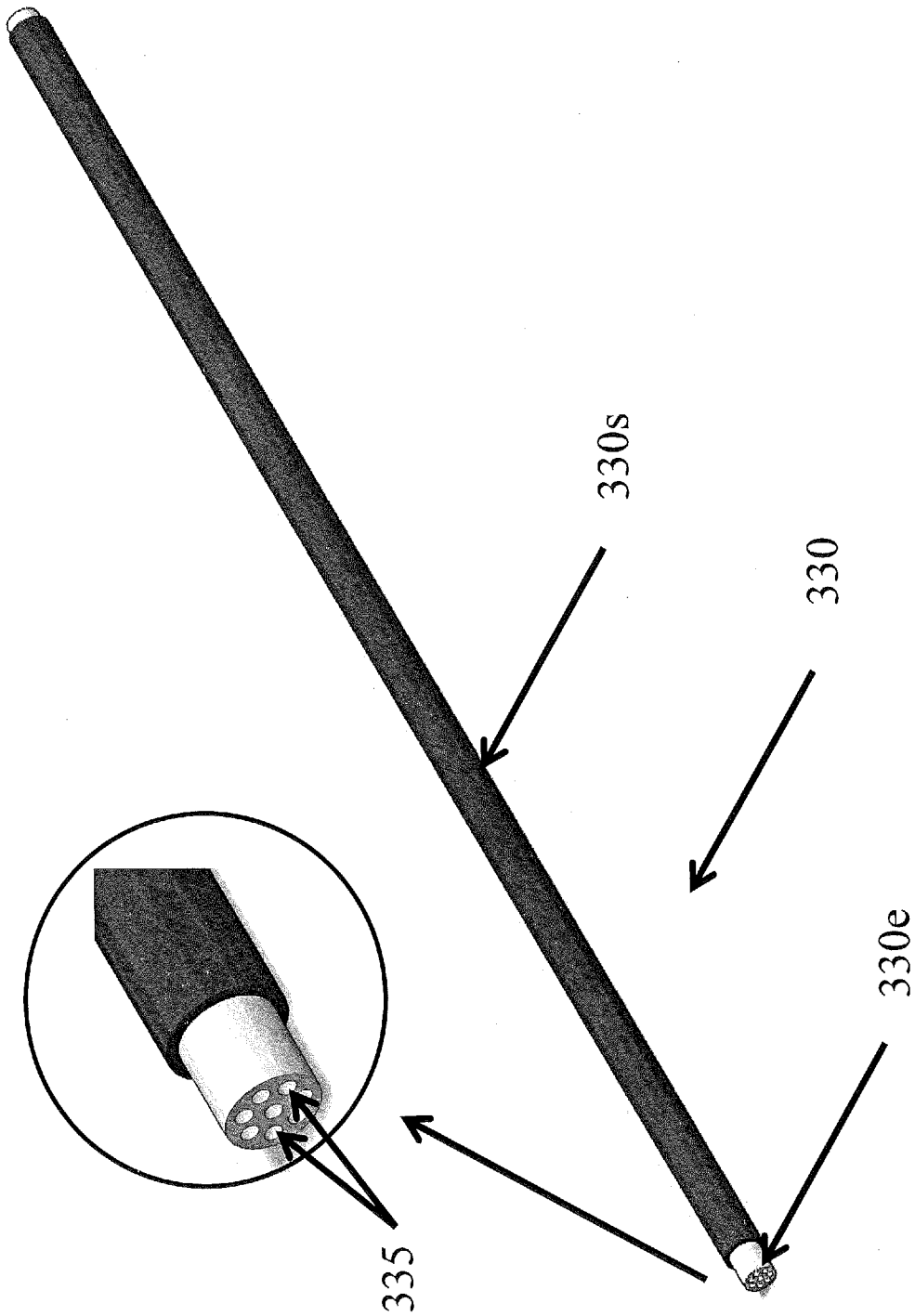

Figure 21

# INTERNATIONAL SEARCH REPORT

International application No.  
PCT/US2010/051631

## Box No. II Observations where certain claims were found unsearchable (Continuation of item 2 of first sheet)

This international search report has not been established in respect of certain claims under Article 17(2)(a) for the following reasons:

1.  Claims Nos.:  
because they relate to subject matter not required to be searched by this Authority, namely:
  
2.  Claims Nos.: 33-39, 41, 42  
because they relate to parts of the international application that do not comply with the prescribed requirements to such an extent that no meaningful international search can be carried out, specifically:  
see FURTHER INFORMATION sheet PCT/ISA/210
  
3.  Claims Nos.:  
because they are dependent claims and are not drafted in accordance with the second and third sentences of Rule 6.4(a).

## Box No. III Observations where unity of invention is lacking (Continuation of item 3 of first sheet)

This International Searching Authority found multiple inventions in this international application, as follows:

1.  As all required additional search fees were timely paid by the applicant, this international search report covers all searchable claims.
  
2.  As all searchable claims could be searched without effort justifying an additional fees, this Authority did not invite payment of additional fees.
  
3.  As only some of the required additional search fees were timely paid by the applicant, this international search report covers only those claims for which fees were paid, specifically claims Nos.:
  
4.  No required additional search fees were timely paid by the applicant. Consequently, this international search report is restricted to the invention first mentioned in the claims; it is covered by claims Nos.:

### Remark on Protest

- The additional search fees were accompanied by the applicant's protest and, where applicable, the payment of a protest fee.
- The additional search fees were accompanied by the applicant's protest but the applicable protest fee was not paid within the time limit specified in the invitation.
- No protest accompanied the payment of additional search fees.

**INTERNATIONAL SEARCH REPORT**

International application No  
PCT/US2010/051631

**A. CLASSIFICATION OF SUBJECT MATTER**  
 INV. B04B5/04  
 ADD.  
 According to International Patent Classification (IPC) or to both national classification and IPC

**B. FIELDS SEARCHED**  
 Minimum documentation searched (classification system followed by classification symbols)  
 B04B A61M

Documentation searched other than minimum documentation to the extent that such documents are included in the fields searched

Electronic data base consulted during the international search (name of data base and, where practical, search terms used)  
 EPO-Internal

**C. DOCUMENTS CONSIDERED TO BE RELEVANT**

Category*	Citation of document, with indication, where appropriate, of the relevant passages	Relevant to claim No.
X	US 4 056 224 A (LOLACHI HOUSHANG) 1 November 1977 (1977-11-01)	1-7, 18, 19, 22, 29-32, 40
Y	the whole document	8-17, 20, 28, 43
X	----- EP 0 260 034 A1 (ALFA LAVAL SEPARATION AB [SE]) 16 March 1988 (1988-03-16)	1-5, 15, 16, 18, 19, 21, 23-27, 29-32, 40
Y	column 4, line 12 - column 6, line 36; figures 1-3 ----- -/--	43

Further documents are listed in the continuation of Box C.

See patent family annex.

\* Special categories of cited documents :

<p>"A" document defining the general state of the art which is not considered to be of particular relevance</p> <p>"E" earlier document but published on or after the international filing date</p> <p>"L" document which may throw doubts on priority claim(s) or which is cited to establish the publication date of another citation or other special reason (as specified)</p> <p>"O" document referring to an oral disclosure, use, exhibition or other means</p> <p>"P" document published prior to the international filing date but later than the priority date claimed</p>	<p>"T" later document published after the international filing date or priority date and not in conflict with the application but cited to understand the principle or theory underlying the invention</p> <p>"X" document of particular relevance; the claimed invention cannot be considered novel or cannot be considered to involve an inventive step when the document is taken alone</p> <p>"Y" document of particular relevance; the claimed invention cannot be considered to involve an inventive step when the document is combined with one or more other such documents, such combination being obvious to a person skilled in the art.</p> <p>"&amp;" document member of the same patent family</p>
--	--

Date of the actual completion of the international search  11 February 2011	Date of mailing of the international search report  18/02/2011
---	--

Name and mailing address of the ISA/ European Patent Office, P.B. 5818 Patentlaan 2 NL - 2280 HV Rijswijk Tel. (+31-70) 340-2040, Fax: (+31-70) 340-3016	Authorized officer  Leitner, Josef
--	--

## INTERNATIONAL SEARCH REPORT

International application No  
PCT/US2010/051631

C(Continuation). DOCUMENTS CONSIDERED TO BE RELEVANT		
Category*	Citation of document, with indication, where appropriate, of the relevant passages	Relevant to claim No.
X	WO 2009/062714 A1 (MILTENYI BIOTEC GMBH [DE]; SCHIMMELPFENNIG WINFRIED [DE]; LANTOW HOLGE) 22 May 2009 (2009-05-22) page 13, line 19 - page 14, line 11; figures	1-5, 23-26, 29-32
X	----- US 4 372 484 A (LARSSON LARS-AKE L [SE] ET AL) 8 February 1983 (1983-02-08)  column 4, line 45 - column 7, line 48; figures	1-5, 23-26, 29-32
Y	----- US 4 146 172 A (CULLIS HERBERT M ET AL) 27 March 1979 (1979-03-27) figures	8-14
Y	----- US 5 665 048 A (JORGENSEN GLEN [US]) 9 September 1997 (1997-09-09) cited in the application figures	15-17
Y	----- US 4 114 802 A (BROWN RICHARD I) 19 September 1978 (1978-09-19) figure 1	20,28
Y	----- US 6 051 146 A (GREEN TODD CURTIS [US] ET AL) 18 April 2000 (2000-04-18) * abstract; figures	8,43
	-----	

## INTERNATIONAL SEARCH REPORT

Information on patent family members

International application No

PCT/US2010/051631

Patent document cited in search report	Publication date	Patent family member(s)	Publication date
US 4056224	A	01-11-1977	AU 507995 B2 06-03-1980
			AU 1203876 A 22-09-1977
			BR 7601897 A 28-09-1976
			CA 1048464 A1 13-02-1979
			DE 2612990 A1 21-10-1976
			DK 119576 A 28-09-1976
			ES 446428 A1 01-11-1977
			FI 760813 A 28-09-1976
			FR 2305239 A1 22-10-1976
			GB 1537096 A 29-12-1978
			IT 1058594 B 10-05-1982
			JP 51120469 A 21-10-1976
			JP 58003747 B 22-01-1983
			NL 7603038 A 29-09-1976
NO 761021 A 28-09-1976			
EP 0260034	A1	16-03-1988	DE 3763784 D1 23-08-1990
			JP 1633804 C 20-01-1992
			JP 2049788 B 31-10-1990
			JP 63119861 A 24-05-1988
			SE 454414 B 02-05-1988
			SE 8603851 A 13-03-1988
			US 4778444 A 18-10-1988
WO 2009062714	A1	22-05-2009	DE 102007054339 A1 28-05-2009
			EP 2200747 A1 30-06-2010
			US 2010261596 A1 14-10-2010
US 4372484	A	08-02-1983	NONE
US 4146172	A	27-03-1979	CA 1090749 A1 02-12-1980
			DE 2845364 A1 19-04-1979
			FR 2406478 A1 18-05-1979
			GB 2006058 A 02-05-1979
			JP 1473563 C 27-12-1988
			JP 54064893 A 25-05-1979
			JP 63014628 B 31-03-1988
US 5665048	A	09-09-1997	AU 1345497 A 17-07-1997
			DE 69606558 D1 09-03-2000
			DE 69606558 T2 21-06-2000
			EP 0868219 A1 07-10-1998
			JP 3320737 B2 03-09-2002
			JP 11504857 T 11-05-1999
			WO 9723297 A1 03-07-1997
US 4114802	A	19-09-1978	NONE
US 6051146	A	18-04-2000	CA 2281649 A1 22-07-1999
			DE 69926313 D1 01-09-2005
			DE 69926313 T2 20-04-2006
			DE 69931085 T2 26-04-2007
			EP 0973564 A1 26-01-2000
			ES 2243043 T3 16-11-2005
			JP 3299284 B2 08-07-2002
			JP 2000514103 T 24-10-2000
			WO 9936111 A1 22-07-1999

# INTERNATIONAL SEARCH REPORT

Information on patent family members

International application No

PCT/US2010/051631

Patent document cited in search report	Publication date	Patent family member(s)	Publication date
-----			

**FURTHER INFORMATION CONTINUED FROM PCT/ISA/ 210**

Continuation of Box II.2

Claims Nos.: 33-39, 41, 42

The present application contains 43 claims, of which 9 are independent. There is no clear distinction between the independent claims because of overlapping scope. There are so many claims, and they are drafted in such a way that the claims as a whole are not in compliance with the provisions of clarity and conciseness of Article 6 PCT, as it is particularly burdensome for a skilled person to establish the subject-matter for which protection is sought. The non-compliance with the substantive provisions is to such an extent, that the search was performed taking into consideration the non-compliance in determining the extent of the search (PCT Guidelines 9.19 and 9.25). The search was based on the subject-matter that, as far as can be understood, could reasonably be expected to be claimed later in the procedure, and the corresponding claims, namely 1-32, 40 and 43.

The applicant's attention is drawn to the fact that claims relating to inventions in respect of which no international search report has been established need not be the subject of an international preliminary examination (Rule 66.1(e) PCT). The applicant is advised that the EPO policy when acting as an International Preliminary Examining Authority is normally not to carry out a preliminary examination on matter which has not been searched. This is the case irrespective of whether or not the claims are amended following receipt of the search report or during any Chapter II procedure. If the application proceeds into the regional phase before the EPO, the applicant is reminded that a search may be carried out during examination before the EPO (see EPO Guideline C-VI, 8.2), should the problems which led to the Article 17(2) declaration be overcome.