

(19) World Intellectual Property Organization
International Bureau



(43) International Publication Date
1 April 2010 (01.04.2010)

(10) International Publication Number
WO 2010/035201 A2

(51) International Patent Classification:
B65D 90/48 (2006.01) *G08C 17/02* (2006.01)
B65D 88/34 (2006.01)

Dale [CA/CA]; 1082 Mount Newton X-Road, Victoria,
British Columbia V8M 1S2 (CA).

(21) International Application Number:
PCT/IB2009/054117

(74) Agent: **THOMSON, J. Gordon**; Suite 2045, 1027 Pandora Avenue, Victoria, British Columbia V8V 3P6 (CA).

(22) International Filing Date:
21 September 2009 (21.09.2009)

(81) Designated States (unless otherwise indicated, for every kind of national protection available): AE, AG, AL, AM, AO, AT, AU, AZ, BA, BB, BG, BH, BR, BW, BY, BZ, CA, CH, CL, CN, CO, CR, CU, CZ, DE, DK, DM, DO, DZ, EC, EE, EG, ES, FI, GB, GD, GE, GH, GM, GT, HN, HR, HU, ID, IL, IN, IS, JP, KE, KG, KM, KN, KP, KR, KZ, LA, LC, LK, LR, LS, LT, LU, LY, MA, MD, ME, MG, MK, MN, MW, MX, MY, MZ, NA, NG, NI, NO, NZ, OM, PE, PG, PH, PL, PT, RO, RS, RU, SC, SD, SE, SG, SK, SL, SM, ST, SV, SY, TJ, TM, TN, TR, TT, TZ, UA, UG, US, UZ, VC, VN, ZA, ZM, ZW.

(25) Filing Language: English

(26) Publication Language: English

(30) Priority Data:
61/194,005 24 September 2008 (24.09.2008) US

(71) Applicant (for all designated States except US):
SYSCOR RESEARCH AND DEVELOPMENT INC.
[CA/CA]; Suite 201, 60 Bastion Square, Victoria, British Columbia V8W1J2 (CA).

(84) Designated States (unless otherwise indicated, for every kind of regional protection available): ARIPO (BW, GH, GM, KE, LS, MW, MZ, NA, SD, SL, SZ, TZ, UG, ZM, ZW), Eurasian (AM, AZ, BY, KG, KZ, MD, RU, TJ, TM), European (AT, BE, BG, CH, CY, CZ, DE, DK, EE, ES, FI, FR, GB, GR, HR, HU, IE, IS, IT, LT, LU, LV,

(72) Inventors; and

(75) Inventors/Applicants (for US only): **TZONEV, Nikolay Nikolov** [CA/CA]; Unit 211, 2174 Cadboro Bay Road, Victoria, British Columbia V8R 5H1 (CA). **SHPAK,**

[Continued on next page]

(54) Title: APPARATUS FOR THE WIRELESS REMOTE MONITORING OF COVERED FLOATING STORAGE TANK ROOFS

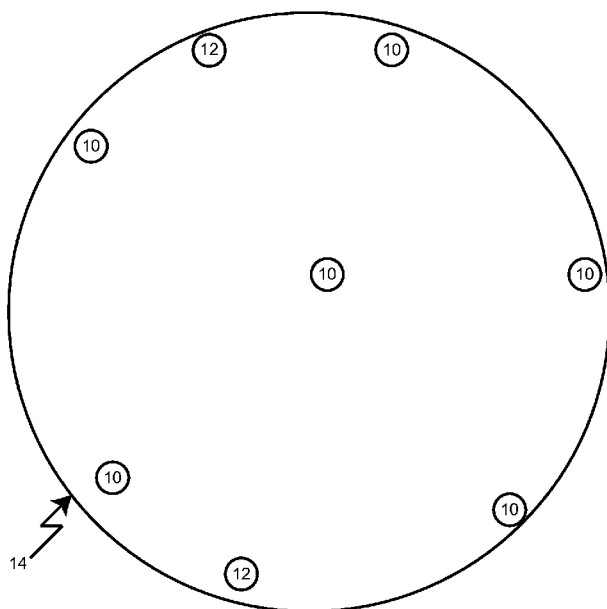

FIG. 1

(57) Abstract: An apparatus for the wireless and remote monitoring of covered floating storage tanks monitors roof position, flexure, fires and the presence of vapours or liquids from water, hydrocarbons or other chemicals. The apparatus relies upon one or more encapsulated intelligent sensor units and communication units. The sensors are deployed on the floating roof of a storage tank and the communication units are deployed near the top wall of the floating roof storage tank or on the fixed roof of the tank.

WO 2010/035201 A2



MC, MK, MT, NL, NO, PL, PT, RO, SE, SI, SK, SM,
TR), OAPI (BF, BJ, CF, CG, CI, CM, GA, GN, GQ, GW,
ML, MR, NE, SN, TD, TG).

- *as to the applicant's entitlement to claim the priority of the earlier application (Rule 4.17(iii))*
- *of inventorship (Rule 4.17(iv))*

Declarations under Rule 4.17:

- *as to the identity of the inventor (Rule 4.17(i))*
- *as to applicant's entitlement to apply for and be granted a patent (Rule 4.17(ii))*

Published:

- *without international search report and to be republished upon receipt of that report (Rule 48.2(g))*

Apparatus for the Wireless Remote Monitoring of Covered Floating Storage Tank Roofs

CROSS-REFERENCE TO RELATED APPLICATIONS

5 This application claims the benefit of United States Provisional Patent Application 61/194,005 filed with the USPTO on September 24, 2008

The Inventors have filed a related application regarding uncovered floating storage tank roofs as disclosed in PCT Application PCT/CA2009/000388, filed on March 24, 2009.

10

FIELD OF THE INVENTION

This invention relates to the remote monitoring of the floating roofs of large storage tanks, including tanks used for storing liquid petroleum products or other chemicals where the floating
15 roof is covered by a roof that is fixed to the top of the tank. The invention is used to monitor roof position, flexure, and other conditions such as fires or the presence of vapors or liquids from water, hydrocarbons, or other chemicals. The invention can be connected to a monitoring system using wired or wireless means and can be used for routine status monitoring or for notifying
plant operators in the event of alarm conditions. The invention can be completely self-contained
20 and is suitable for encapsulation and use in harsh environments.

BACKGROUND OF THE INVENTION

Large storage tanks are often cylindrical and have a circular floating roof. The roof floats on the surface of the liquid, thereby decreasing the vapor space inside of the tank. A floating roof may
5 be required for reasons of safety or for pollution reduction. The floating roof has a seal to seal it to the wall of the tank that helps to prevent the escape of the contained liquid or vapors from that liquid.

There are two broad types of storage tanks that utilize floating roofs: tanks having an exposed
10 floating roof and tanks having a fixed roof covering the floating roof. An advantage of the covered tank is that it protects the floating roof from undesirable effects from the external environment, such as rain or birds. A disadvantage of the covered tank is that volatile, explosive, corrosive, or toxic gasses or liquids can accumulate between the floating roof and the fixed roof.

15 The floating roof is a large dynamic structure having a diameter of up to 100 meters and weighing several tons. This dynamic structure is subjected to changing forces from environmental conditions (temperature, wind, etc.) that affect the tank, the lid, or the contained liquid; convective forces within the liquid; or forces that occur when liquid is added or removed, including friction from the seal. The roof will flex and possibly tilt in response to these changes,
20 which may result in the loss of the contained liquid or vapor into the space between the floating roof and the fixed roof. In extreme cases, the roof may tilt enough to cause it to sink into the tank.

The industry is therefore quite interested in monitoring systems that can be used to improve safety, reduce environmental concerns, or avoid major problems such as seal failure or a sunken roof.

5

There are existing patents that address the application of electronic monitoring or control to storage tank systems. For example, US patent 4,596,266 (Kinghorn, et al.,1986) describes an electronic safety valve and system for controlling the roof drain on a hydrocarbon storage tanks for the purpose of allowing water drainage while preventing the escape of the contained liquid.

10 US patent 4,176,553 (Wood, 1979) describes a system for measuring the level of a liquid in a storage tank having a predetermined reference level. Although these patents are applied to storage tanks, they are essentially unrelated to the invention described herein. There is no existing art that addresses the roof monitoring system described herein.

15 US patent 6,700,503 (Masar, et al. 2004) describes a means for wireless remote monitoring and graphically displaying the liquid level inside of a tank. The invention described herein does not incorporate a graphical display.

WIPO PCT filing 94/26627 (Christensen, 1994) describes a system for estimating the inclination
20 of a storage tank roof by using float-based liquid level sensors and reed switches whereas the invention described herein uses solid-state micro electro-mechanical devices to directly measure inclination.

There is a considerable body of literature, standards, and patents that describe wireless sensor networks. A representative book that describes the current art is *Protocols and Architectures for Wireless Sensor Networks* by Karl Holger and Andreas Willig (Wiley, 2005).

5

US patent 7,339,957 (Hitt, 2008) describes how transmission time slots are allocated to transmitting nodes in a system of wireless environmental sensors and actuators for the purpose of controlling irrigation systems. Although the invention described herein utilizes environmental sensors, it does use actuators nor does it rely upon a slotted communications protocol.

10

US patent 7,386,352 (Davis, et al., 2008) describes a modular sensor network node architecture where the node architecture has each sensor coupled to its own small microprocessor so that it can be "plugged" into a sensor node containing a master microprocessor. The invention described herein is not modular and requires only a single microprocessor.

15

US patent 7,468,661 (Petite et al. 2008) describes a system and method for monitoring and controlling remote devices. This patent describes a variety of application areas but does not address storage tank monitoring. In its Detailed Description, this patent "describes the data structure of messages sent and received using the invention". Throughout its claims, the

20

communications system requires a retransmission device (e.g., "one or more retransmitting receivers") or a "computer program that formats and stores select information for retrieval on demand". The invention described herein does not require any of these components.

BRIEF SUMMARY OF THE INVENTION

The present invention provides a new apparatus for monitoring floating tank roofs where the floating roof is covered by a fixed roof. The invention comprises one or more intelligent Sensor Units and one or more Communication Units. The Sensor Unit integrates multiple sensors into a self-contained unit that can be completely encapsulated for use in harsh environments.

Additionally, any Unit may have a magnetic base for rapid installation on steel tank roofs. Each Communication Unit communicates with the Sensor Units and with a Monitoring System. The Communication Unit can be used to relay information from the Sensor Units to or from a Monitoring System and may contain a microprocessor for sensor fusion or for computing alarm conditions.

Each Sensor Unit incorporates a power source and communicates with the Communication Unit using a wireless communications link. Therefore, the Sensor Unit does not require any external wiring, thereby simplifying deployment and improving reliability. It may also be encapsulated, thereby further improving reliability. The Sensor Units may also communicate with each other, either to share information or to improve network reliability by providing alternate communication paths (e.g., mesh networking).

20

It is also possible to use radio-frequency power transmission or optical means to wirelessly provide power to the Units. Both of these methods are well-known in the existing art.

The Sensor Unit is comprised of several functional units including a microcontroller; a wireless communication module; an inclinometer or tilt sensor; and a liquid and/or vapor sensor (such as a hydrocarbon sensor). Any combination of other functional modules may be incorporated into
5 any particular Sensor Unit: a temperature sensor; and a flame sensor.

There is no known existing apparatus that is similar to the current invention.

BRIEF DESCRIPTION OF THE DRAWINGS

10

Figure 1: Conceptual Plan View of the System Deployed on a Tank Roof

Figure 2: Functional Block Diagram of the Sensor Unit

Figure 3: Liquid Level Measurement Technique

Figure 4: Use of a Channel to Protect the Vapor Sensor from Immersion

15 Figure 5: Submerged Sensor Unit

DETAILED DESCRIPTION OF THE INVENTION

With reference to the conceptual plan view of a deployed system in Figure 1, the invention
20 consists of one or more encapsulated intelligent Sensor Units 10 and one or more
Communication Units 12. The Sensor Units 10 are deployed on the floating roof of the tank

whereas the Communication Units 12 are normally located near the top of the wall of the tank or on the fixed roof.

The Sensor Units 10 communicate with one or more Communication Units 12 via wireless means. As shown in Figure 1, a plurality of Communication Units 12 can be employed, thereby adding redundancy to the system and improving the overall system reliability. Communication reliability can also be enhanced by allowing Sensor Units 10 to relay communications through other Sensor Units 10 (e.g., mesh networking).

10 With reference to the functional block diagram in Figure 2, said Sensor Unit 10 minimally comprises a power module 26 and the following core functional modules: a microcontroller 16; a communications module 18; an inclinometer or tilt sensor 28; and a liquid sensor 20 or vapor sensor 30. Optional functional modules that can be incorporated to enhance the utility of the Sensor Unit include: additional vapor 30 or liquid sensors 20; a pressure sensor 32; a temperature
15 sensor 22; and a flame sensor 24.

Sensor Units 10 need not be functionally identical. For example, there may be a need for more tilt sensors 28 than flame sensors 24 for a particular deployment scenario.

20 With reference to Figure 2, the connecting lines between the microcontroller 16 and the modules indicate communication links and are shown as being bidirectional but unidirectional connections are also possible. The communication link for the power module 26 is optional.

The Sensor Unit 10 is powered by a power module 26 employing batteries, photovoltaic cells, radio-frequency power transmission, optical power transmission, or any combination thereof.

The Communication Unit 12 can be line powered, use power-over-ethernet, use batteries, use
5 photovoltaic cells, or any combination thereof.

For the purpose of identifying each Sensor Unit 10, each Sensor Unit 10 is uniquely identified by one or more identification numbers: an electronic identification number that is set up during system configuration or a unique electronic identification number that is set up before system
10 configuration. The identification number need not be globally unique: it can be unique to a particular deployment.

In the current embodiment, the Communication Unit 12 is comprised of a Texas Instruments MSP430 microcontroller; a Texas Instruments CC2520 communications module for
15 communicating with the Sensor Units 10; a Cirrus Logic CS8900A Ethernet Controller; and a power module 26 that is connected to line power and contains a rechargeable battery pack as a secondary source of power. The Communication Unit 12 wirelessly communicates with the Sensor Units 10 and communicates with an external Monitoring System over ethernet. The Communication Unit 12 can be used to relay information to or from the Sensor Units 10 and to
20 or from a Monitoring System.

The microprocessor 16 is programmable and can have software for supporting sensor fusion or for computing alarm conditions. Optionally, the microprocessor 16 can be re-programmed in the field by wired or wireless means.

- 5 For either the Communication Unit 12 or the Sensor Unit 10, the microcontroller and the communications module may be integrated into a single device such as the Freescale MC13224.

The Communication Unit 12 uses known technologies and is not described further.

- 10 The Sensor Unit 10 is preferentially encapsulated for use in harsh environments, including but not limited to chemical plants, petrochemical plants, and marine environments. The alternative to encapsulation is mechanical sealing systems, such as enclosures sealed with gaskets. The Sensor Unit 10 is preferentially weatherproof and immersible.
- 15 Preferentially, each Sensor Unit 10 incorporates a magnetic base 38 for rapid attachment to ferrous metal structures such as the floating lid of a storage tank. It may also be mounted using adhesives or mechanical means including fasteners or clamps.

- In the current embodiment of the Sensor Unit 10, the core functional modules displayed in
- 20 Figure 2 are implemented using: a Texas Instruments MSP430 microcontroller; a Texas Instruments CC2520 communications module; an Analog Devices ADIS16209 digital inclinometer; and an ultrasonic liquid sensor that is described next.

With reference to Figure 3, the preferred embodiment of the ultrasonic liquid sensor is comprised of an ultrasonic transducer 40; an electronics module for the transducer; and an acoustically-reflective surface 42, which may be the surface of the tank roof. In response to a command
 5 signal from the microcontroller 16, the transducer 40 emits an acoustic pulse 44 toward said reflective surface 42 located at a known distance d_2 50. The first reflection from said pulse 44 will be received by the transducer 40 after a propagation delay of

$$t_S = \frac{2d_1}{v_A}$$

where t_S is the round-trip propagation delay for the pulse; d_1 48 is the distance to the surface 46
 10 of the liquid; and v_A is the velocity of acoustic propagation in the ambient atmosphere. Since we can use well-known methods to measure the propagation delay t_S , and we know the distance d_2 50 and v_A , we can use this equation to accurately determine the depth ($d_2 - d_1$) of the liquid. If d_1 is computed to be approximately equal to d_2 , then no measurable amount of liquid is present.

15 The utility of the invention can be enhanced by additionally considering a second reflection due to the acoustic pulse being reflected by the acoustically-reflective surface 42. The round-trip propagation delay, t_2 , of said second pulse is given by

$$t_2 = \frac{2d_1}{v_A} + \frac{2(d_2 - d_1)}{v_L}$$

where v_L is the velocity of acoustic propagation in the liquid. Since we can use the previous
 20 equation (for t_S) to determine d_1 48 and we know v_A and d_2 50, we can use this new equation to determine v_L . In many practical application areas, such as the storage of petrochemicals, v_L can be used to determine if the liquid that is detected by the liquid sensor is the stored liquid, water,

or a combination thereof. This type of liquid sensor and the techniques and the specific components required for its implementation are known in the existing state of the art.

The current embodiment of the Sensor Unit 10 includes the following optional sensor modules:

- 5 an e2v Technologies IR603 hydrocarbon vapor sensor; a Texas Instruments TMP275 temperature sensor; and a General Monitors FL4000 Multi-Spectral Infrared Flame Detector.

Since the Sensor Unit 10 is designed to be immersible, the vapor sensor should be protected from contact with possibly damaging liquids. With reference to the conceptual cross-sectional

- 10 diagram in Figure 4, this is accomplished by placing the vapor sensor 52 inside of a hollow channel or dome. As the liquid level rises into said channel 54, the atmospheric pressure inside of the channel 54 increases. As shown in Figure 5, this increase in atmospheric pressure in the entrained atmosphere 60 prevents the liquid from rising into the channel 54 far enough to reach the vapor sensor 52.

15

With reference to Figure 4, the channel 54 preferentially contains a means, such as a rotary or piezoelectric fan 56 or a pump 58, for circulating the ambient atmosphere across the surface of the vapor sensor 52. The operation of said circulation device is controlled by the microcontroller 16. In Figure 4, the conceptual flow of atmosphere is indicated by curved arrows.

20

Communications among the system components (the Sensor Units 10, the Communication Units 12, and the Monitoring System) may be initiated using one or more of the methods described in

the following four paragraphs. In all cases, communications between any Sensor Unit 10 and the Monitoring System must pass through one or more Communication Units 12.

The Monitoring System can send a request to one or more Sensor Units 10. The Sensor Units 10
5 will subsequently reply with the requested information. This type of communications is referred to as polling.

The Sensor Units 10 can send periodic status messages to the Monitoring System. These periodic messages can contain information from the sensors; alarm status; and/or information
10 regarding the state of the Sensor Unit 10, such as battery condition. This type of communications is referred to as periodic.

The Sensor Units 10 can send messages to the Monitoring System in the event that that an alarm condition has been detected by one or more Sensor Units 10. This type of communication is
15 referred to as event-driven.

The Sensor Units 10 can communicate with each other to exchange sensor status and/or they can act as communications relays to improve the reliability or the range of the wireless communication system. This type of communication is referred to as local.
20

Communications between the Sensor Units 10 and/or Communication Units 12 can use mesh networking protocols to improve reliability.

This invention can be used to address critical concerns in industrial applications. Notably, government regulation in the petroleum industry requires the industry to comply with stringent safety and emissions standards. This invention can be used not only for monitoring the sensor
5 readings and generating alarm signals but also for monitoring vapors at discrete locations in the tank and calculating total tank emissions (incorporating temperature and pressure data) for the purpose of government reporting and deciding on when to replace the seals.

Although the description above contains much specificity, these should not be construed as
10 limiting the scope of the invention but as merely providing illustrations of the presently preferred embodiment of this invention. Thus the scope of the invention should be determined by the appended claims and their legal equivalents.

15

20

What is claimed is:

1. A system for monitoring the state of a covered floating storage tank roof and its local environment where said system requires no external wiring, comprising: a wireless communication device for communicating with other such systems or for communicating with a unidirectional communications relay device; a tilt sensor to measure the local inclination of the tank roof; a liquid sensor to measure the level of liquid accumulation on the tank roof; and a microcontroller that is connected to said wireless communication device and that monitors the status of said sensors.
2. The system of claim 1, further comprising a vapor sensor such as a hydrocarbon vapor sensor that is used to detect vapors that may have been released from the storage tank.
3. The system of claim 1, further comprising a temperature sensor that is used for measuring the ambient temperature.
4. The system of claim 1, wherein said liquid sensor uses ultrasonic time-of-flight information and the system computes both the depth and acoustic velocity for any liquid that is present.
5. The system of claim 1, wherein the wireless communication system is bidirectional.

6. The system of claim 1, wherein system power is provided using photovoltaic cells that are physically attached to the system.

7. The system of claim 1, wherein system power is provided using radio-frequency power transmission.

8. The system of claim 1, wherein system power is provided using batteries contained within the system.

9. The system of claim 1, further comprising a magnetic means for attaching the system to the tank roof.

10. The system of claim 1, wherein the system is encapsulated or mechanically sealed to protect it from its external environment.

11. The system of claim 2, wherein the vapor sensor is protected from immersion by placing the vapor sensor within a physical channel within the system.

12. The system of claim 2, further comprising a fan or pump to circulate ambient vapors across the vapor sensor.

13. The system of claim 1, wherein the system periodically sends information using said communications relay device.

14. The system of claim 1, wherein the system sends information using said communications relay device whenever an alarm condition has been detected by the system and wherein said alarm condition comprises the detection of any of: excessive inclination; excessive liquid accumulation; excessive accumulation of the contained liquid; or extreme temperature.

15. A system comprising one or more of systems of the type described in claim 1, each hereinafter referred to as a Sensor Unit, and one or more communications relay devices that relay information to or from a supervisory or control system, each hereinafter referred to as a Communication Unit.

16. The system of claim 15, wherein the Sensor Units are wirelessly interconnected using a mesh networking topology to improve communications reliability.

17. The system of claim 15, wherein a polling protocol is used by the Communication Units to request information from the Sensor Units.

1/5

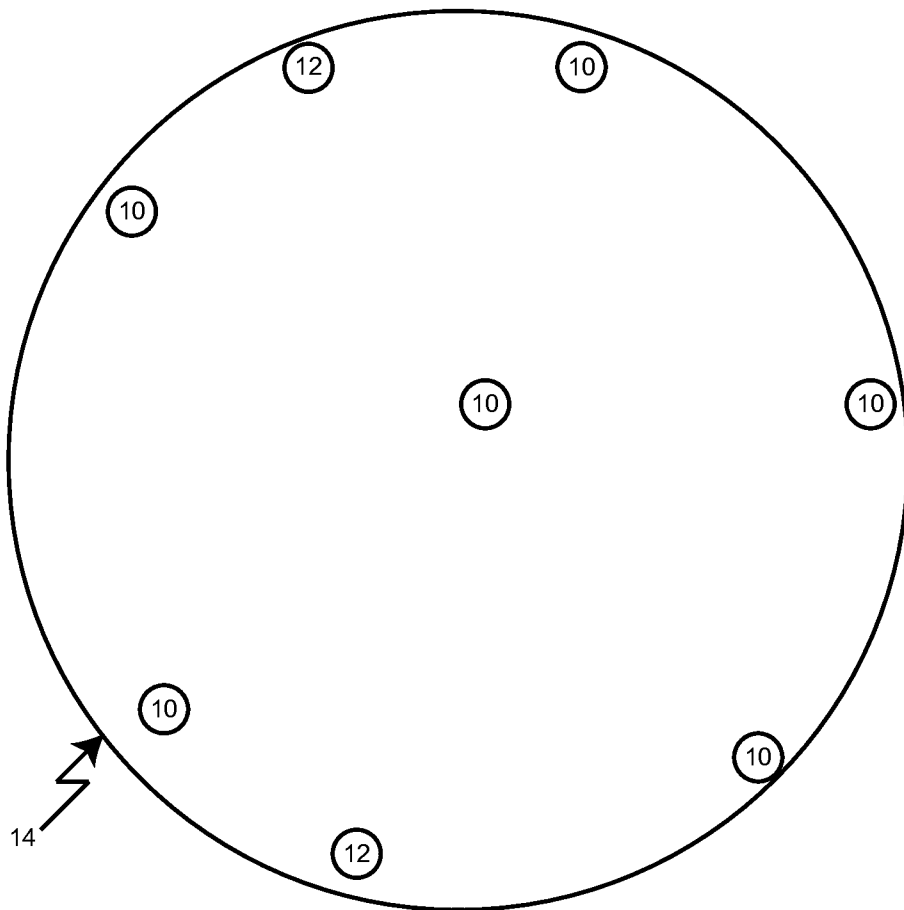

FIG. 1

2/5

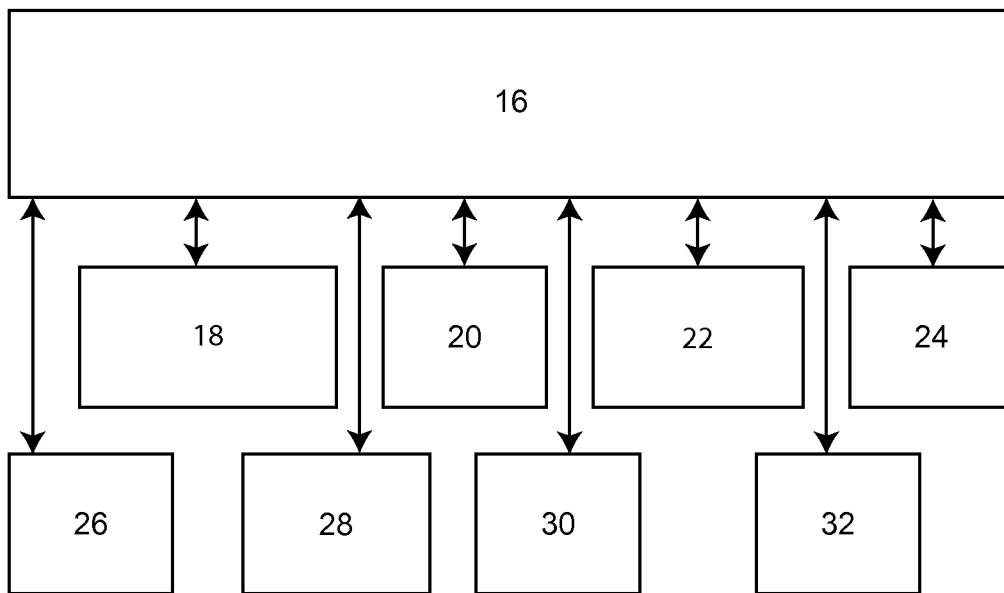

FIG. 2

3/5

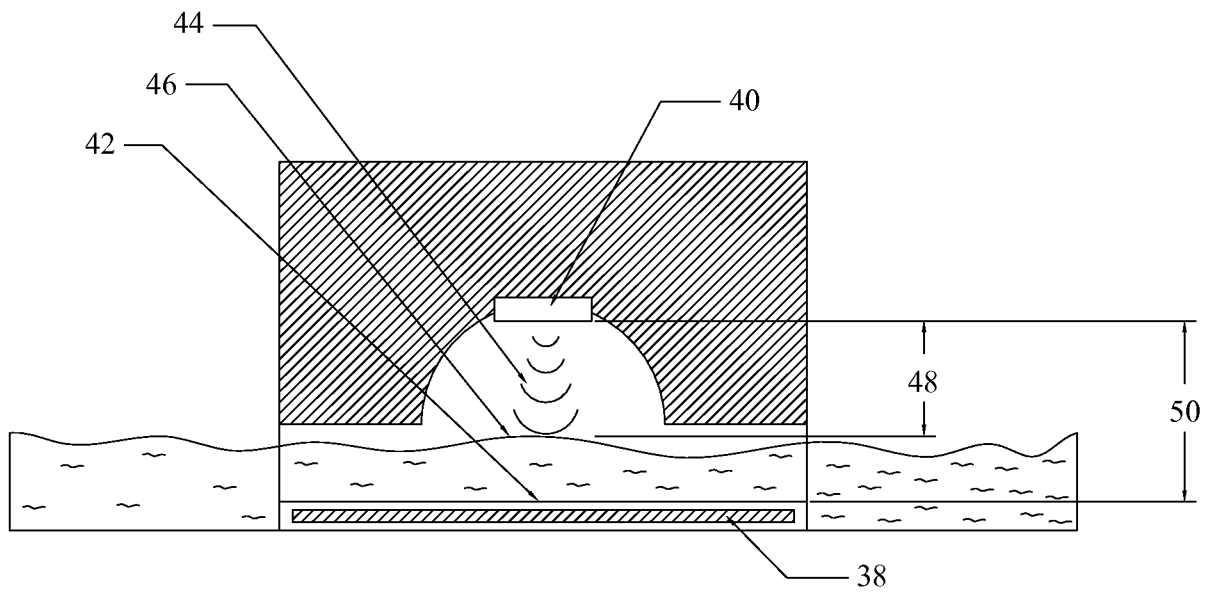

FIG. 3

4/5

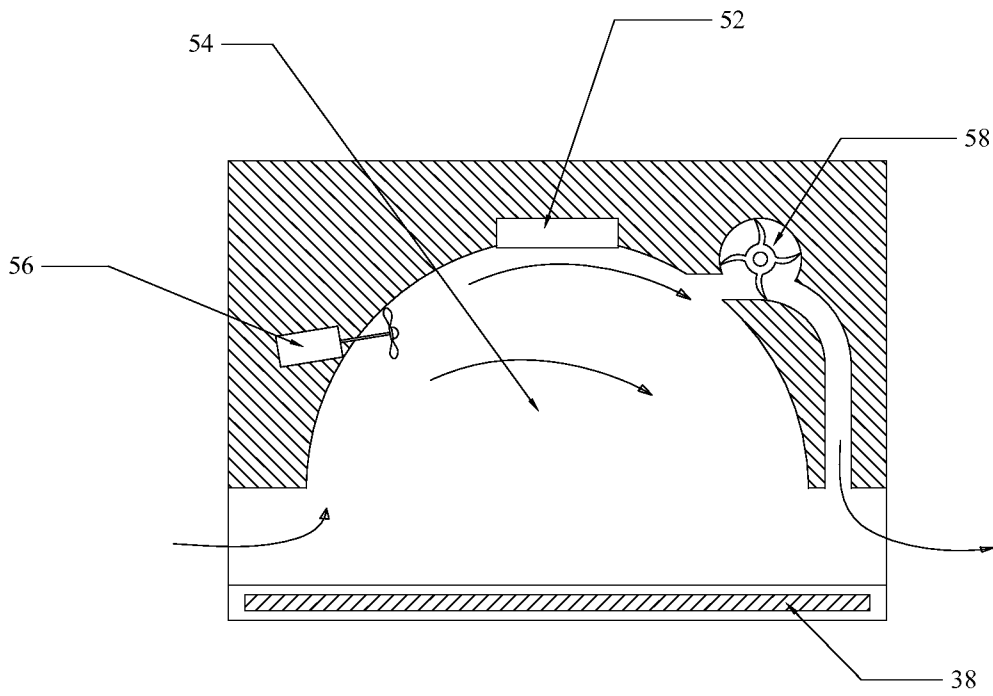

FIG. 4

5/5

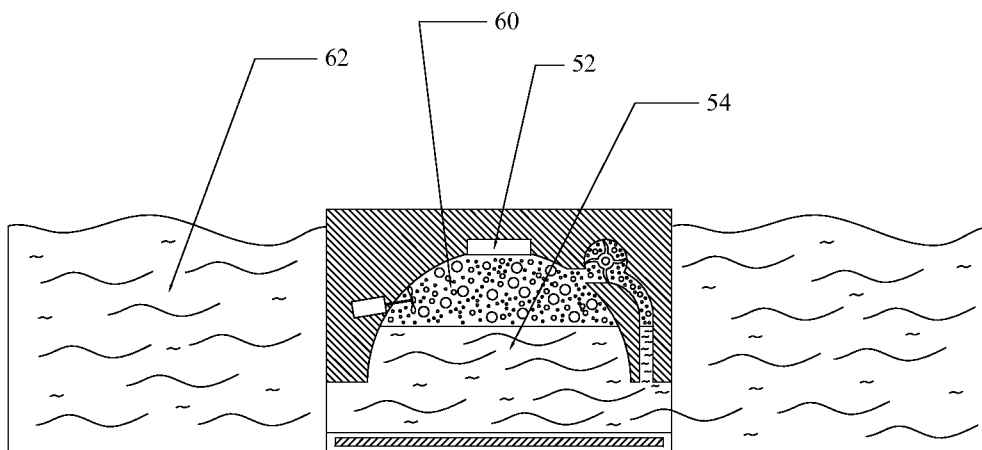

FIG. 5