

Fig. 1

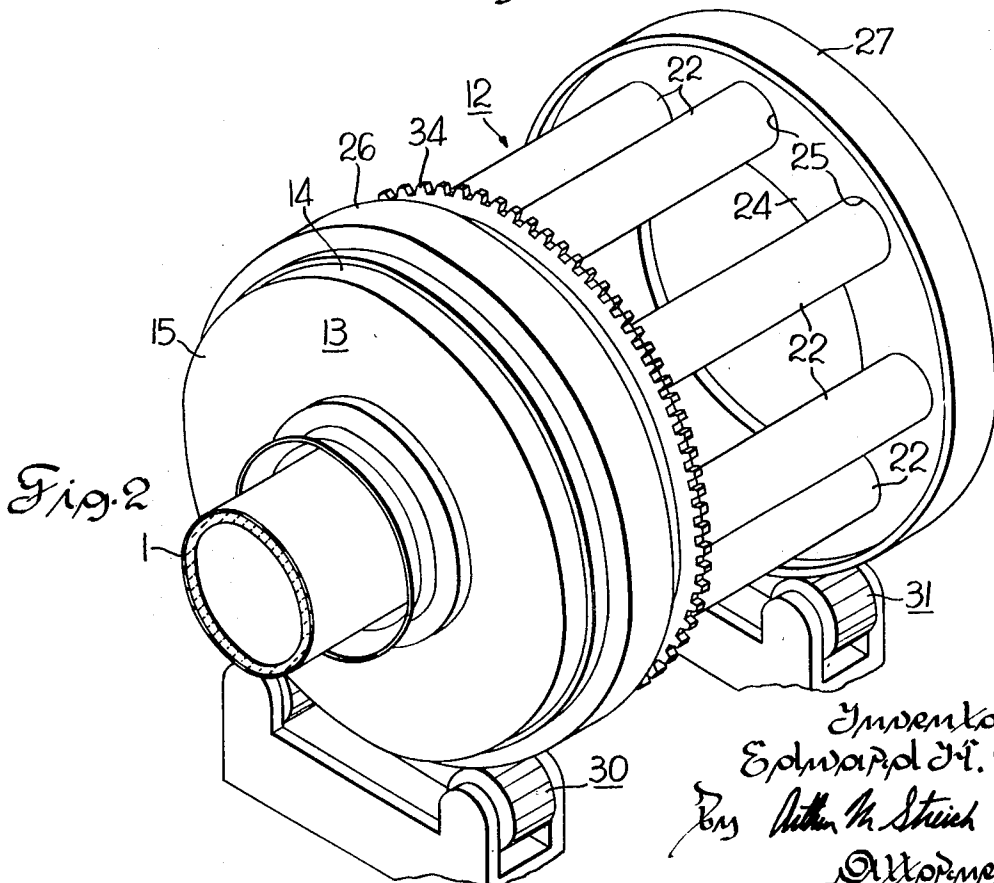

Fig. 2

Inventor  
Edward H. Baxa  
By *Arthur M. Strick*  
Attorney

## TUBULAR ROTARY COOLER

## BACKGROUND OF THE INVENTION

## 1. Field of the Invention

This invention relates to rotary kiln and cooler installations and in particular to a rotary cooler assembly having a plurality of tubes arranged in a ringlike cluster with each tube parallel to the kiln, and adapted to receive hot material from the rotary kiln, for cooling in the tubes.

## 2. Description of the Prior Art

Rotary kiln and tubular cooler installations having a ringlike cluster of tubular coolers arranged around the discharge end of the kiln to rotate with the kiln are shown in such patents as U.S. Pat. No. 2,173,182 of 1939 and U.S. Pat. No. 2,740,620 of 1956. An arrangement in which a rotating cluster of material distributing tubes are arranged in an annular ring projecting axially away from the discharge end of a kiln and fed from ports in an end section of a kiln having reduced diameter, is shown in U.S. Pat. No. 3,358,977 of 1967.

The arrangements taught by the foregoing prior art cannot be applied to large diameter kilns. Kilns designed with larger diameters must also be made longer, to maintain length to diameter ratios that meet process requirements, and the capacity and cooling air requirements increase as approximately the third power of an increase in kiln diameter. However, the surface available for mounting cooling tubes increases at only about a 1:1 ratio with increased diameter. Thus increasing kiln diameter calls for more cooling tubes which must be brought closer together. There is a limit as to how close together such tubes can be placed before the ports in the kiln shell come so close together as to weaken the kiln structure and therefore there is a diameter size limit for such installations. It is to this problem that the present invention is directed and a new and improved solution thereto is its principal object.

## SUMMARY OF THE PRESENT INVENTION

A rotary kiln and tubular cooler installation according to the present invention not only achieves the aforesaid principal object relative to the described prior art, but also achieves other objects. Another such object of the present invention is to provide a cluster of cooling tubes that may be turned about a central axis at a rate independent of kiln speed.

Another object of the present invention is to provide a structure between a kiln and cooler tubes that can be made large enough to support a sufficient number of tubes to reduce air velocity through each tube to permit hot materials to flow into all tubes without being hindered by the oppositely flowing cooling air.

In a preferred embodiment of the present invention a rotary kiln engages a cooler assembly having a material receiving and distributing drum of larger diameter than the kiln. The drum has a first end wall which is annular and surrounds the discharge end of the kiln. The drum has a second end wall defining a plurality of material discharge ports arranged around its outer circumference. A material-cooling tube is connected to each port with all tubes parallel to the outer shell of the drum. The tubes each have a discharge opening on an end thereof remote from said drum. Support means engage the assembly for carrying the drum and tubes for rotation about a central axis sloped downwardly from the drum toward the tube discharge openings. Means engage the cooler assembly for turning the drum and cluster of tubes around the central axis at a rate independent of the rotation of the kiln; and the large diameter drum, between the kiln into each of the tubes.

Other features and objects of the invention that have been attained will appear from the more detailed description to follow with reference to an embodiment of the present invention shown in the accompanying drawing.

## BRIEF DESCRIPTION OF THE DRAWING

FIG. 1 of the accompanying drawing shows diagrammatically a side elevation, partly in section, a rotary kiln and cooler according to the present invention; and

FIG. 2 is a view, in perspective, of apparatus shown in FIG. 1.

## DESCRIPTION OF THE PREFERRED EMBODIMENT

Referring to the drawing, a portion of a rotary kiln shell 1 and its discharge end 2 is shown having a riding ring 4 mounted around its circumference, and a roller support assembly 5 which engages ring 4 to carry the kiln shell 1 for rotation about a central axis  $x-x$  sloped downwardly slightly toward the discharge end 2. A drive means for turning the kiln shell 1 about the central axis  $x-x$ , includes a motor 6 that drives a pinion gear 7 which in turn engages a girth gear 8 mounted around the kiln shell 1. The rotary kiln shell 1 may be provided with a refractory lining 9 and the discharge end 2 may be constructed to retain such lining 9 as described in U.S. Pat. No. 3,016,236 and including an annular cooling jacket 10.

Associated with the discharge end 2 of the kiln shell 1, is a cooler 12 arranged to receive hot material spilling from the discharge end 2 of kiln 1 and cool such hot material with air which is thereby preheated for use as combustion air in the kiln. The cooler 12 is an assembly including a material receiving and distributing drum 13 having a cylindrical shell 14, a first end wall 15 and a second end wall 16. The first end wall 15 is an annular end wall defining a central material receiving opening 17 surrounding the discharge end 2 of the rotary kiln 1. The second end wall 16 defines a plurality of material discharge ports 20 at the outer circumference of wall 16. The drum 13, so formed by shell 14 and end walls 15, 16, has a diameter greater than the distance between end walls 15, 16 along the axis  $x-x$ .

A cluster of material cooling tubes 22 project from the drum 13 in a direction away from the rotary kiln 1. Each one of the tubes 22 is connected to enclose one of the ports 20, there being a tube 22 for each such port 20, and each tube 22 has a discharge opening 23 on the end thereof remote from the drum 13. An annular ring 24, having holes 25 through which the tubes 22 project, is provided near the discharge opening 23 ends of the tubes 22 to provide support for the tubes at a location axially spaced away from the end wall 16 of the drum 13. In order to support the drum 13 and the annular ring 24, a first riding ring 26 encircles the shell 14 of drum 13 and a second riding ring 27 encircles ring 24. Roller support assemblies 30, 31 engage riding rings 26, 27 to thereby carry the entire cooler assembly 12 for rotation about the axis  $x-x$ . Cooler drive means are provided that include a motor 32 that drives a pinion gear 33 which in turn engages a girth gear 34 which may be mounted on the outer periphery of the shell 14 of drum 13.

A burner 36, for the rotary kiln 1, projects through a central opening 37 in end wall 16 of drum 13. The burner 36 extends through the drum 13 and projects a short distance into the discharge end 2 of the rotary kiln 1. An annular seal 38 is provided around the discharge end 2 of the rotary kiln 1. This seal 38 may be of a well-known type, as shown in U.S. Pat. No. 2,266,396 to C. S. Lincoln et al. and U.S. Pat. No. 2,332,724 to W. C. Johnson. The seal 38 comprises an annular seal ring 39, which may be attached to the outer periphery of the cooling jacket 10, and the ring 39 projects into an annular hood 40 attached to end wall 15 of the drum 13.

In the operation of the described apparatus, material moving down the slight downward slope of the kiln 1, turned about axis  $x-x$  by motor 6, spills out through the discharge end of kiln 1 and falls into the drum 13. Drum 13 and the cooling tubes 22 projecting therefrom, are also sloped downwardly, along the central axis  $x-x$ , toward the discharge openings 23 on the ends of tubes 22. The drum 13 and cluster of tubes 22,

are turned about axis  $x-x$  by the cooler drive motor 32 and material in drum 13 spills uniformly into the tubes 22. As material moves through tubes 22 toward discharge openings 23, air is drawn in the material discharge openings 23 by a draft provided by a stack and exhaust fans connected to the material feed end of the kiln (not shown). Air moving in the material discharge openings 23 and passing through tubes 22 toward drum 13, cools material passing therethrough while such air recuperates heat from the material for return to the kiln as preheated combustion air. The operation of the cooler 12 may be speeded up or slowed down by adjusting the speed of motor 32, without changing the turning speed of the rotary kiln. Thus both the kiln 1 and the cooler 12 may be operated at their own optimum speed to achieve maximum efficiency of both units. Further, tubes 22 may be lengthened, shortened or replaced with greater or fewer numbers of such tubes of the same or different diameters. All the foregoing changes to the cooler may be achieved by merely changing wall 16, ring 24 and the tubes 22; and none of these changes require any rebuilding of the kiln or the shell 14 or wall 15 of the drum 13.

From the foregoing detailed description of the present invention, it has been shown how the objects of the invention have been attained in a preferred manner. However, modifications and equivalents of the disclosed concepts such as readily occur to those skilled in the art are intended to be included within the scope of this invention. Thus, the scope of this invention is intended to be limited solely by the scope of the claims such as are or may hereafter be appended hereto.

The embodiments of the invention in which an exclusive property or privilege is claimed are defined as follows:

1. In a rotary kiln and cooler installation, a generally horizontal rotary kiln, a drive means engaging the kiln for turning the kiln about a central axis passing therethrough, and a cooler engaging with the discharge end of the kiln, the cooler comprising an assembly of: a material receiving and distributing drum having an outer shell having a diameter greater than the diameter of the kiln, and first and second end walls transverse to a central axis passing through said shell; the first end wall being an annular end wall defining a central material receiving opening surrounding the discharge end of the kiln; the second end wall defining a plurality of material discharge ports each arranged in the second wall to be radially outward of the central opening in the first wall; a cluster of material-cooling tubes with one of the tubes being connected to each of the ports in the second end wall of the drum, said tubes being arranged to be parallel to each other and the cen-

tral axis of the drum, and said tubes each having a discharge opening on an end thereof remote from said drum; support means engaging the cooler assembly for carrying the drum and tubes for rotation about said central axis passing through the drum and cluster of tubes and with said axis sloped downwardly from said drum toward said tube discharge openings; and means engaging the cooler assembly operative for turning the drum and cluster of tubes around the central axis at a rate of rotation different than the rate of rotation of the kiln, to distribute material from the drum into the tubes for cooling as such material flows through the tubes to said tube discharge openings.

2. In a kiln and cooler installation according to claim 1, a rotating seal connecting the outer periphery of the kiln to the inner periphery of the surrounding annular end wall to substantially block entry of atmospheric air into the kiln and drum through the annular end wall of the drum.

3. In a kiln and cooler installation according to claim 1, a burner projecting through a central portion of the second end wall of the drum, through the interior of the drum, through the central opening in the first and annular end wall of the drum, and into the discharge end of the kiln.

4. A cooler comprising an assembly of: a material receiving and distributing drum having an outer shell and first and second end walls transverse to a central axis passing through said shell; the first end wall being an annular end wall defining a central material receiving opening; the drum defining a plurality of material discharge ports each arranged radially outward of the central opening in the first wall; a cluster of material cooling tubes with one of the tubes being connected to each of the discharge ports in the drum, said tubes being arranged to be parallel to each other and the central axis of the drum, and said tubes each having a discharge opening on an end thereof remote from said drum; support means engaging the assembly for carrying the drum and tubes for rotation about said central axis passing through the drum and cluster of tubes and with said axis sloped downwardly from said drum toward said tube discharge openings; means engaging the assembly for turning the drum and cluster of tubes around the central axis to distribute material from the drum into the tubes for cooling as such material flows through the tubes to said tube discharge openings; a first riding ring encircling the cylindrical shell of the drum; a second riding ring encircling the annular ring; and roller support means engaging each of the riding rings to carry the drum and cluster of tubes for rotation about the central axis.

50

55

60

65

70

75