



US011189176B2

(12) **United States Patent**
Rech et al.

(10) **Patent No.:** **US 11,189,176 B2**

(45) **Date of Patent:** **Nov. 30, 2021**

(54) **METHOD, DEVICES AND COMPUTER PROGRAM FOR INITIATING OR CARRYING OUT A COOPERATIVE DRIVING MANEUVER**

(71) Applicant: **VOLKSWAGEN AKTIENGESELLSCHAFT, Wolfsburg (DE)**

(72) Inventors: **Bernd Rech, Bokensdorf (DE); Stefan Gläser, Braunschweig (DE); Monique Engel, Braunschweig (DE); Bernd Lehmann, Wolfsburg (DE); Sandra Kleinau, Rötgesbüttel (DE); Hendrik-Jörn Günther, Hannover (DE); Teodor Buburuzan, Braunschweig (DE); Axel Köhnke, Dülmen (DE)**

(73) Assignee: **Volkswagen Aktiengesellschaft**

(*) Notice: Subject to any disclaimer, the term of this patent is extended or adjusted under 35 U.S.C. 154(b) by 0 days.

(21) Appl. No.: **16/086,929**

(22) PCT Filed: **Mar. 15, 2017**

(86) PCT No.: **PCT/EP2017/056121**

§ 371 (c)(1),

(2) Date: **Sep. 20, 2018**

(87) PCT Pub. No.: **WO2017/167580**

PCT Pub. Date: **Oct. 5, 2017**

(65) **Prior Publication Data**

US 2019/0098471 A1 Mar. 28, 2019

(30) **Foreign Application Priority Data**

Mar. 29, 2016 (DE) 10 2016 205 142.3

(51) **Int. Cl.**
G08G 1/00 (2006.01)
G08G 1/16 (2006.01)
H04W 4/46 (2018.01)

(52) **U.S. Cl.**
CPC **G08G 1/22** (2013.01); **G08G 1/162** (2013.01); **G08G 1/167** (2013.01); **H04W 4/46** (2018.02); **G08G 1/166** (2013.01)

(58) **Field of Classification Search**
CPC G08G 1/166; G08G 1/167; G08G 1/0112; G08G 1/012; G08G 1/0133; G08G 1/0141;

(Continued)

(56) **References Cited**

U.S. PATENT DOCUMENTS

8,810,431 B2 8/2014 Mudalige et al.
9,550,528 B1 * 1/2017 Hakeem G08G 1/162
(Continued)

FOREIGN PATENT DOCUMENTS

CN 102066185 A 5/2011
CN 102431556 A 5/2012
(Continued)

OTHER PUBLICATIONS

Search Report for German Patent Application No. 10 2016 205 142.3; dated Jan. 20, 2017.

(Continued)

Primary Examiner — Golam Sorowar

(74) *Attorney, Agent, or Firm* — Barnes & Thornburg LLP

(57) **ABSTRACT**

A method, devices and computer program for initiating and/or carrying out a cooperative driving maneuver. The method includes a driving intention message for transportation vehicles in an environment of a transportation vehicle which includes information relating to an intention of a

(Continued)

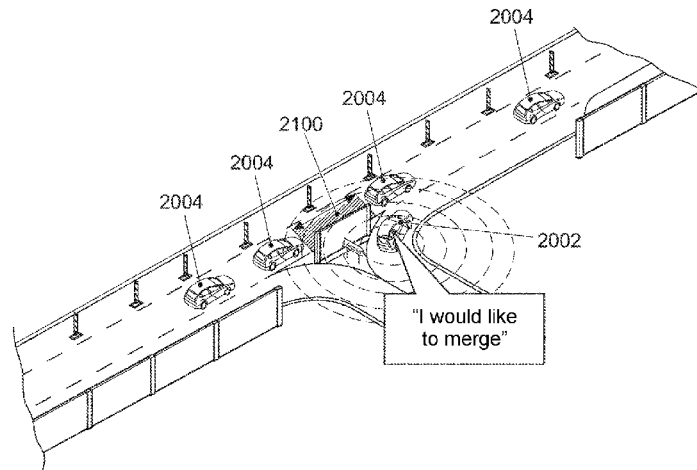

driver or an at least partially automatic transportation vehicle control system of the transportation vehicle to carry out a driving maneuver. The method includes obtaining information relating to a driving intention based on the intention to carry out the driving maneuver, determining a position of the transportation vehicle, determining the driving intention message based on the information relating to the driving intention, and calculating transmission parameters for the driving intention message. The transmission parameters include a repetition rate and a transmission time, and the calculation is based on a desired probability of receipt of the driving intention message, the driving intention, and the position of the transportation vehicle.

14 Claims, 6 Drawing Sheets

(58) **Field of Classification Search**

CPC G08G 1/096716; G08G 1/096725; G08G 1/096741; G08G 1/096775; G08G 1/133; G08G 1/161; G08G 1/162; G08G 1/163; G08G 1/164; B60W 30/08; B60W 10/04; B60W 10/18; B60W 10/20; B60W 2050/008; B60W 2550/30; B60W 2550/402; B60W 2710/18; B60W 2710/20; B60W 2720/10; B60W 2900/00; B60W 30/18163; H04W 4/021; H04W 4/44; H04W 4/90

See application file for complete search history.

(56) **References Cited**

U.S. PATENT DOCUMENTS

2013/0099911 A1* 4/2013 Mudalige G08G 1/163
340/438
2013/0158800 A1 6/2013 Trageser

2014/0107867 A1* 4/2014 Yamashiro G05D 1/0293
701/2
2015/0254977 A1* 9/2015 Grabow G08G 1/163
340/903
2015/0327028 A1* 11/2015 Zhang H04W 4/46
455/452.1
2016/0318511 A1* 11/2016 Rangwala B60W 30/09

FOREIGN PATENT DOCUMENTS

CN	102750837	A	10/2012
CN	103065500	A	4/2013
CN	104960524	A	10/2015
CN	105261236	A	1/2016
DE	19910153	A1	1/2001
DE	102005026693	A1	6/2006
DE	102008040566	A1	1/2010
DE	102012218935	A1	4/2013
DE	102012210344	A1	12/2013
DE	102013001326	A1	7/2014
DE	102013013799	A1	2/2015
DE	102013217434	A1	3/2015
DE	102014002116	A1	8/2015
DE	102014204333	A1	9/2015
DE	102014105474	A1	10/2015
DE	112009001028	B4	5/2017
JP	2016020125	A	2/2016
KR	20150106260	A	9/2015
WO	9963502	A2	12/1999
WO	2009138942	A2	11/2009

OTHER PUBLICATIONS

Search Report for International Patent Application No. PCT/EP2017/056121; dated Jun. 9, 2017.

* cited by examiner

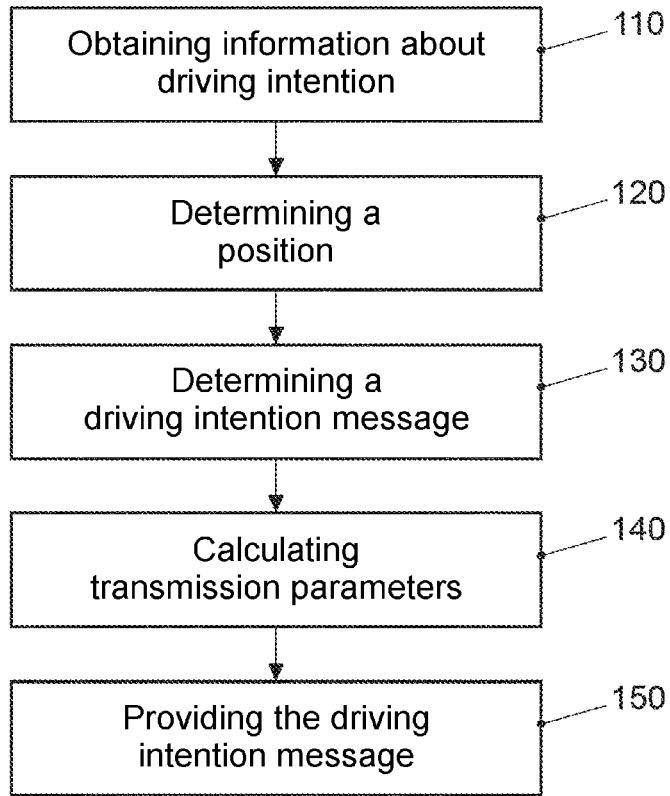

FIG. 1

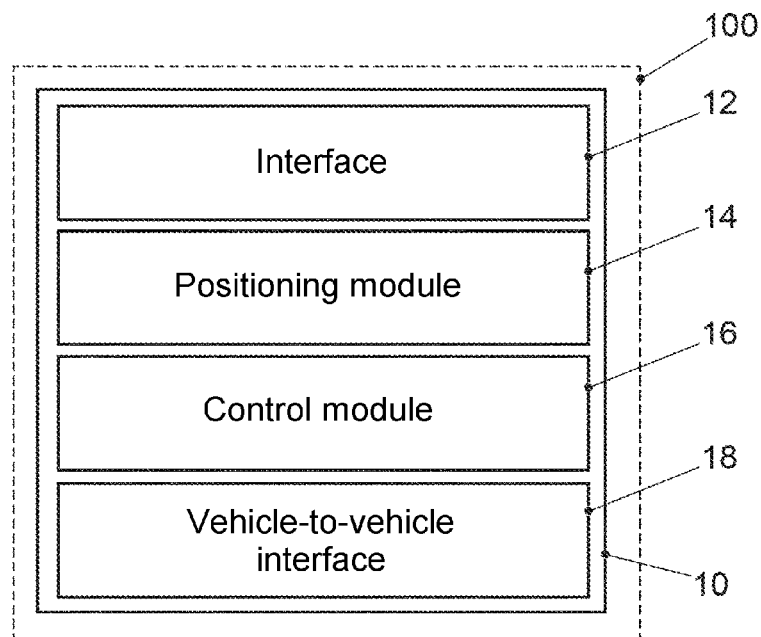

FIG. 1a

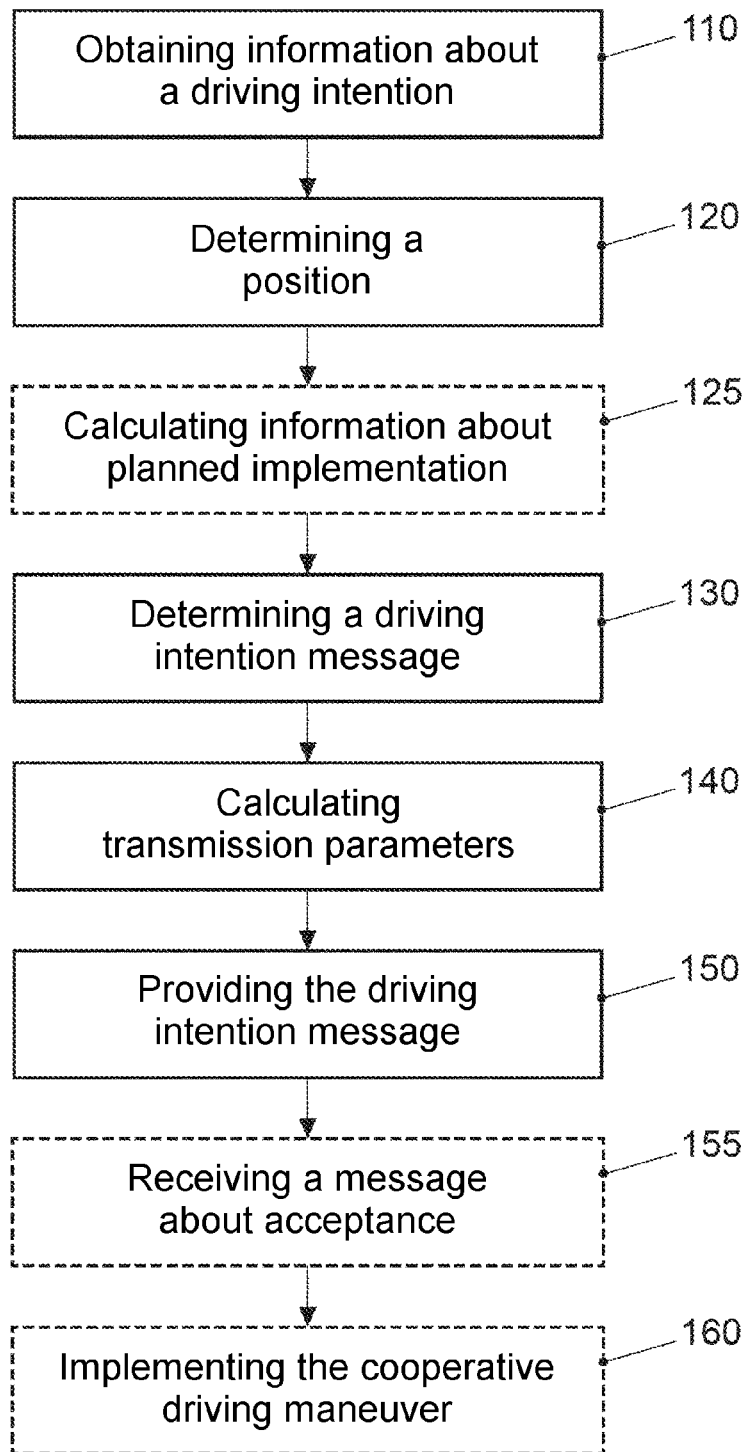

FIG. 1b

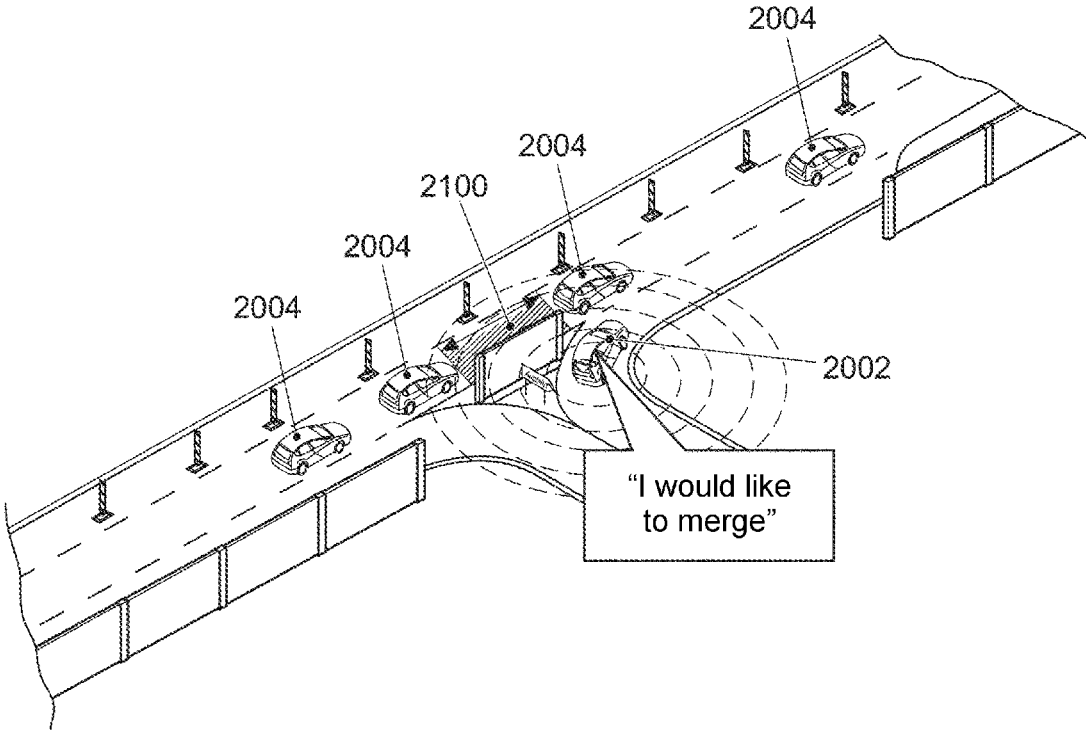

FIG. 2

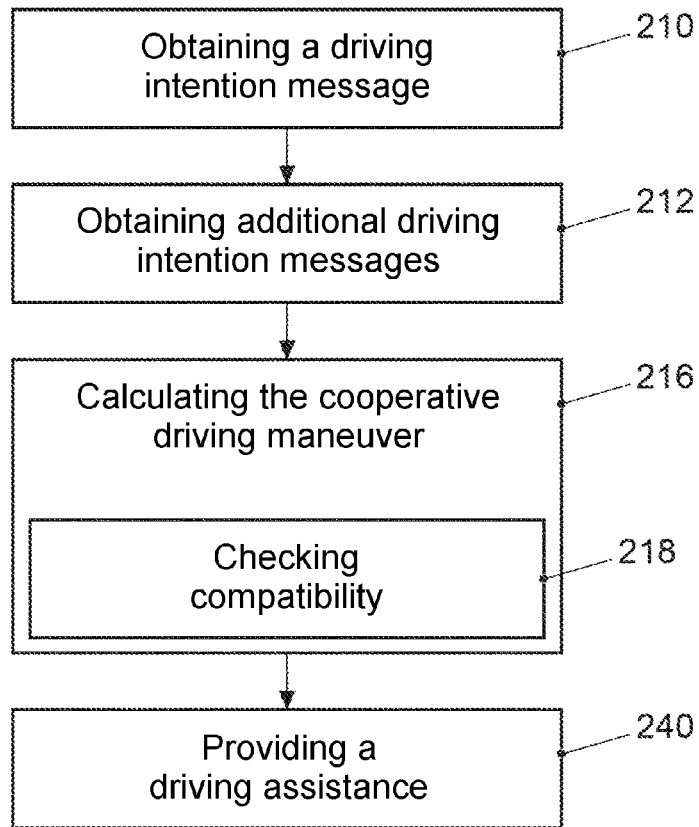

FIG. 3

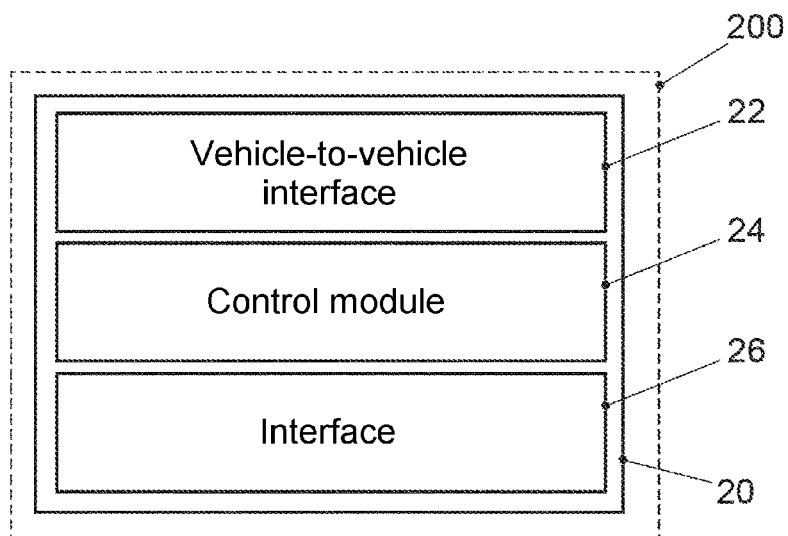

FIG. 3a

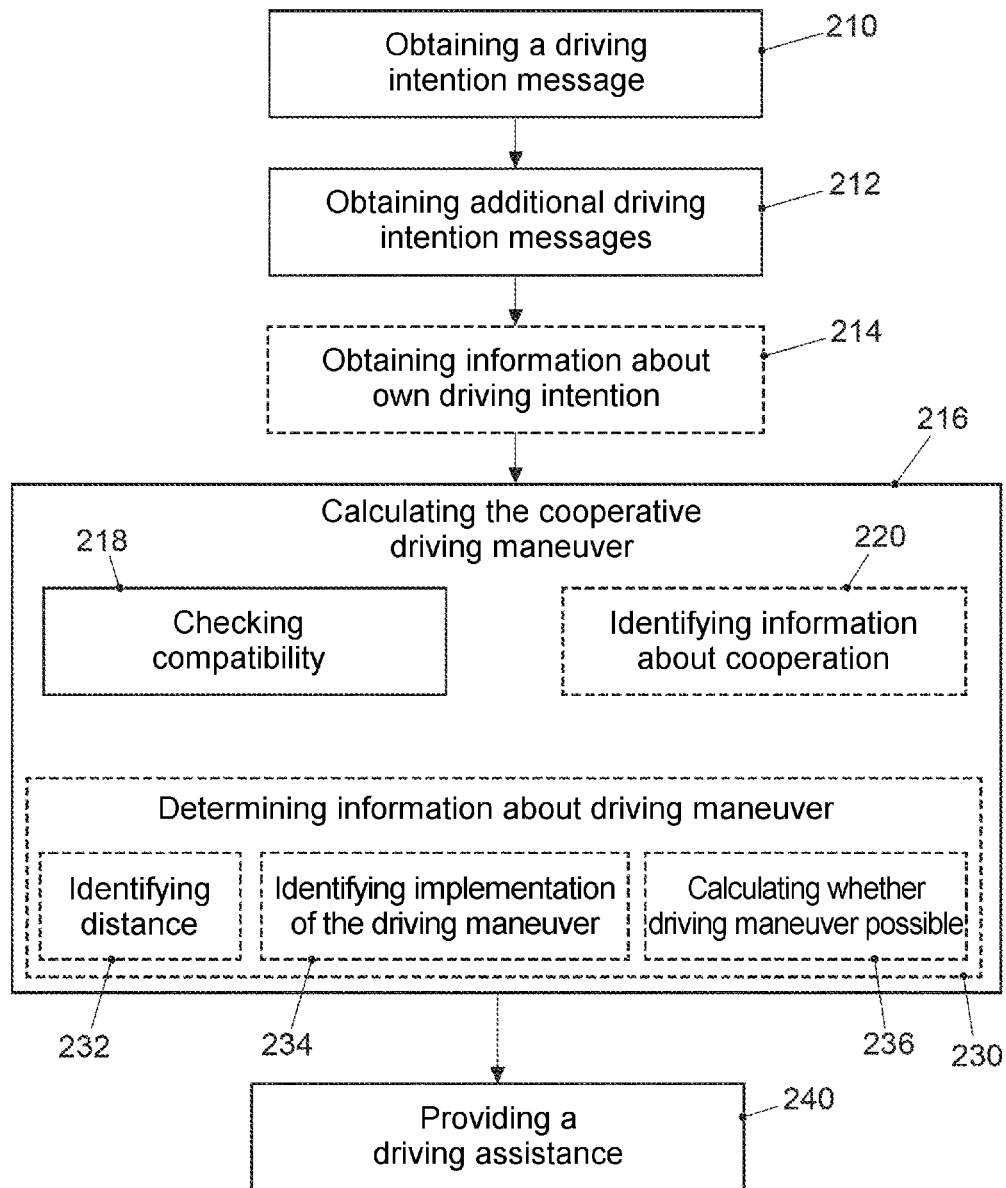

FIG. 3b

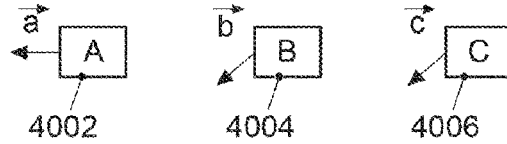

FIG. 4a

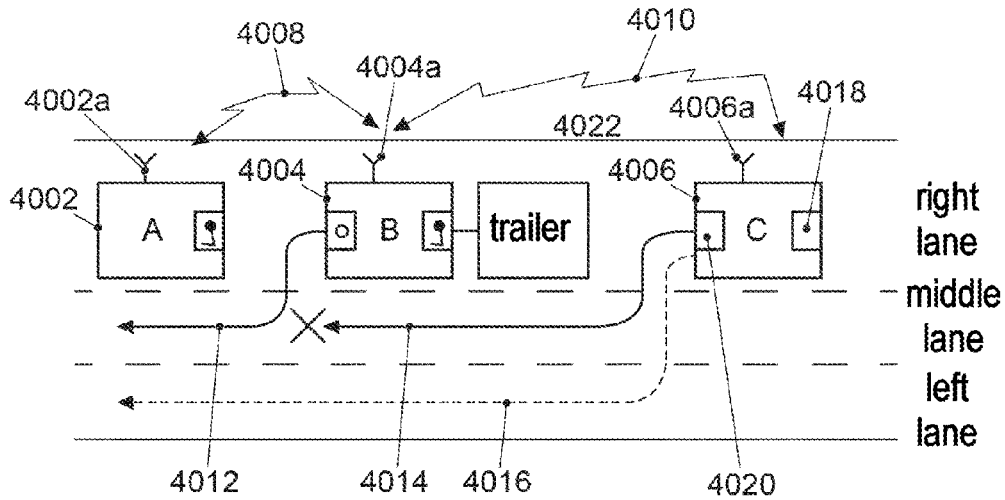

FIG. 4b

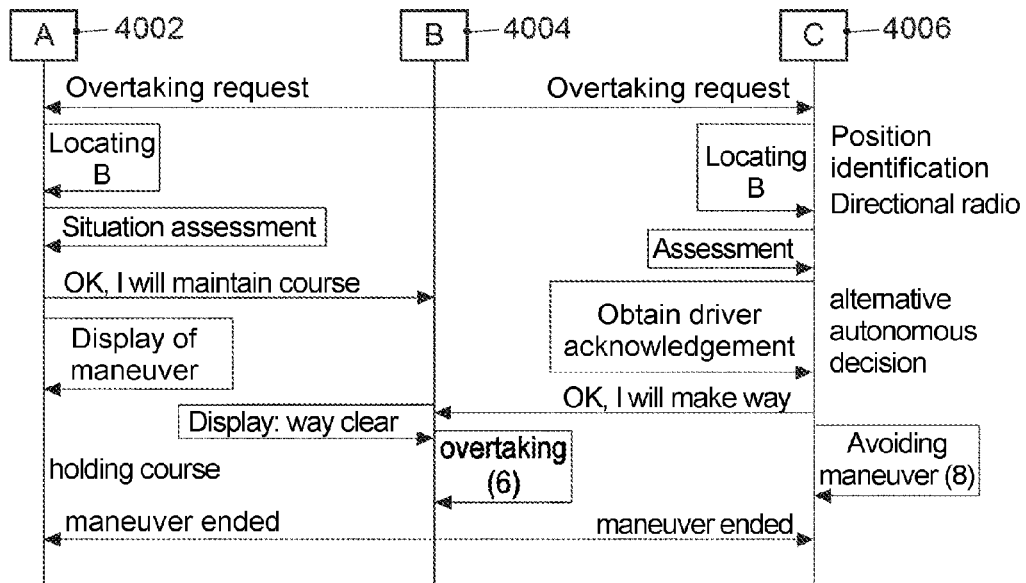

FIG. 4c

1

**METHOD, DEVICES AND COMPUTER
PROGRAM FOR INITIATING OR
CARRYING OUT A COOPERATIVE
DRIVING MANEUVER**

PRIORITY CLAIM

This patent application is a U.S. National Phase of International Patent Application No. PCT/EP2017/056121, filed 15 Mar. 2017, which claims priority to German Patent Application No. 10 2016 205 142.3, filed 29 Mar. 2016, the disclosures of which are incorporated herein by reference in their entireties.

SUMMARY

Illustrative embodiments relate to methods, devices and a computer program for initiating and/or implementing a cooperative driving maneuver, more specifically, but not exclusively, based on driving intention messages which are provided via vehicle-to-vehicle communication.

BRIEF DESCRIPTION OF THE DRAWINGS

Exemplary embodiments are described in detail below based on the drawings, to which exemplary embodiments are not generally limited, however. In the figures:

FIG. 1 illustrates a flow diagram of an exemplary embodiment of a method for initiating a cooperative driving maneuver;

FIG. 1a illustrates a block diagram of an exemplary embodiment of a device for initiating a cooperative driving maneuver;

FIG. 1b illustrates a flow diagram of a further exemplary embodiment of a method for initiating a cooperative driving maneuver;

FIG. 2 shows an example of an exemplary embodiment;

FIG. 3 illustrates a flow diagram of an exemplary embodiment of a method for a transportation vehicle for carrying out a cooperative driving maneuver;

FIG. 3a illustrates a block diagram of an exemplary embodiment of a device for a transportation vehicle for carrying out a cooperative driving maneuver;

FIG. 3b illustrates a flow diagram of a further exemplary embodiment of a method for a transportation vehicle for carrying out a cooperative driving maneuver; and

FIGS. 4a-4c show an example of an exemplary embodiment of a method for carrying out a cooperative driving maneuver.

DETAILED DESCRIPTION

Vehicle-to-vehicle communication (also Car2Car, C2C, or Vehicle2Vehicle, V2V) and vehicle-to-infrastructure communication (also Car2Infrastructure, C2I or Vehicle2Roadside, V2R) are a focal point of automotive research in the 21st century. The communication between transportation vehicles or between transportation vehicles or transport infrastructure allows a multitude of novel possibilities, such as a co-ordination between transportation vehicles or a communication of transportation vehicles with the transport infrastructure, for example, to provide traffic jam warnings to the transportation vehicles. In this situation, the transportation vehicles which are designed for C2C or C2I (also grouped together under vehicle-to-X communication, Car2X, C2X or vehicle2X, V2X) have a transmitting and receiving unit to be able to communicate with other

2

transportation vehicles, for example, via direct radio connections or mobile radio networks. Such communication can be limited, for example, between transportation vehicles or between transportation vehicles and transport infrastructure within a radius of a few hundred meters.

A coordination of transportation vehicles, for example, for the cooperative implementation of maneuvers or for the co-ordination of automated transportation vehicles, is often dependent on the quality of the information about the transportation vehicles which is available in an environment. If transportation vehicles are equipped with vehicle-to-vehicle communication systems, then these can often be co-opted for use in cooperative driving situations.

There is a need for an improved approach to supporting cooperative driving functions. This need is met by the methods and devices in accordance with the independent claims.

Exemplary embodiments create a method for initiating a cooperative driving maneuver. If a transportation vehicle in at least some exemplary embodiments intends to perform a driving maneuver, such as a lane change, then the method can provide driving intention messages via a vehicle-to-vehicle interface to other transportation vehicles in the environment, for example, to inform the latter that the transportation vehicle would like to carry out the maneuver. To enable an increased reception probability, transmission parameters are also calculated, for example, a repetition rate or a transmission time, depending on the position and driving intention. Based on these transmission parameters, the driving intention message is then transmitted to the transportation vehicles in an environment of the transportation vehicle as a direct vehicle-to-vehicle message.

Exemplary embodiments create a method for initiating a cooperative driving maneuver by providing a driving intention message for transportation vehicles in an environment of a transportation vehicle. The driving intention message includes information about an intention of a driver, or an at least partially automatic transportation vehicle control system, of the transportation vehicle to carry out a driving maneuver. The method comprises obtaining information about a driving intention. The driving intention is based on the intention to carry out the driving maneuver. The method further comprises determining a position of the transportation vehicle. The method also comprises determining the driving intention message, based on the information about the driving intention. The method also comprises calculating transmission parameters for the driving intention message. The transmission parameters comprise a repetition rate and a time of transmission. The calculation of the transmission parameters is based on a desired reception probability of the driving intention message, the driving intention and the position of the transportation vehicle. The method also comprises providing the driving intention message as a direct vehicle-to-vehicle message for the transportation vehicles in the environment of the transportation vehicle based on the transmission parameters. The provision of the driving intention message can enable a cooperation of transportation vehicles to facilitate or simplify a driving maneuver, such as a lane change operation. The calculation of the transmission parameters enables an improvement in a transmission probability of the driving intention message, by the transmission being adapted, for example, according to the situation and/or based on the driving intention.

In some exemplary embodiments the method can also comprise receiving a message about acceptance of the cooperative driving maneuver as a response to the driving intention message, from at least one of the transportation

vehicles in the environment of the transportation vehicle. The calculation of the transmission parameters may also be based on the message about the acceptance of the cooperative driving maneuver. The receipt of the message about the acceptance of the cooperative driving maneuver may enable the transportation vehicle to carry out the cooperative driving maneuver with the accepting transportation vehicle. The calculation of the transmission parameters based on the message about the acceptance of the cooperative driving maneuver may also enable an adjustment of the transmission rate (or, for example, a spatially targeted transmission), for example, to reduce the total number of messages and therefore the utilization rate of the radio resources.

In some exemplary embodiments, the method can also comprise carrying out the cooperative driving maneuver, based on the driving intention message and based on the message about the acceptance of the cooperative driving maneuver. The implementation of the cooperative driving maneuver can increase driving safety and enable the transportation vehicle (or a driver of the transportation vehicle) to carry out the driving maneuver more easily.

In at least some exemplary embodiments, the information about the driving intention can comprise information about at least one intention from the set of Single lane change to the left, Single lane change to the right, Double lane change to the left, Double lane change to the right, Triple lane change to the left, Triple lane change to the right, Turning left, Turning right, Pulling out from a parking space and Parking the transportation vehicle. Signaling of the driving intention for transportation vehicles in an environment of the transportation vehicle enables cooperative driving maneuvers and can improve traffic flow.

In at least some exemplary embodiments, determining the driving intention message can also be based on the position of the transportation vehicle. The driving intention message may also comprise information about the position of the transportation vehicle and/or information about a driving lane currently used by the transportation vehicle. Determining the driving intention message based on the position of the transportation vehicle can enable the consideration of road incidents and/or the inclusion of absolute or relative positions of transportation vehicles.

In some exemplary embodiments, the method can also comprise calculating information about a planned implementation of the driving maneuver, based on the position of the transportation vehicle. The information about the planned implementation of the driving maneuver can comprise information about at least one element of the set of first possible lane change point, planned lane change point, last possible lane change point, and phase of the driving maneuver. The driving intention message may also comprise the information about the planned implementation of the driving maneuver. The provision of the information about the planned implementation of the driving maneuver can enable a better co-ordination of the cooperative driving maneuver and/or allow a relevance assessment for the transportation vehicles in the surrounding area, i.e., an assessment of whether the driving intention message is relevant to them.

Exemplary embodiments also create a method for a transportation vehicle for carrying out a cooperative driving maneuver. The method comprises obtaining a driving intention message from a requesting transportation vehicle. The driving intention message comprises information about an intention of a driver, or of an at least partially automatic transportation vehicle control system, of the transportation vehicle to carry out a driving maneuver. The method also comprises receive one or more other driving intention mes-

sages of transportation vehicles in an environment of the transportation vehicle. The one or more other driving intention messages comprise information about one or more driving intentions of the transportation vehicles in an environment of the transportation vehicle. The method also comprises calculating the cooperative driving maneuver based on the driving intention message of the requesting transportation vehicle and on the one or more other driving intention messages of the transportation vehicles in an environment of the transportation vehicle. The calculation of the cooperative driving maneuver comprises checking whether the cooperative driving maneuver is compatible with the one or more driving intentions of the transportation vehicles in an environment of the transportation vehicle. The method also comprises providing a driving assistance to implement the cooperative driving maneuver, provided the cooperative maneuver is compatible with the one or more further driving intention messages of the transportation vehicles in an environment of the transportation vehicle. The method can enable an implementation of the cooperative driving maneuver, for example, allowing for possible further driving intention messages of other transportation vehicles, for example, to be better able to coordinate driving maneuvers in the event of incompatibility of a plurality of driving intentions, and/or to improve traffic flow.

In some exemplary embodiments, the method can also comprise obtaining information about a driving intention on the part of the transportation vehicle. The calculation of the cooperative driving maneuver may also be based on the information about the transportation vehicle's own driving intention. The checking operation can also check whether the cooperative driving maneuver is compatible with the transportation vehicle's own driving intention. The provision can also be based on whether the cooperative driving maneuver is compatible with the transportation vehicle's own driving intention. The allowance for the transportation vehicle's own driving intention can enable a continuing co-ordination and cooperation, for example, by allowing driving maneuvers over a plurality of driving lanes.

In at least some exemplary embodiments the driving maneuver can be a simple lane change maneuver to the left. The calculation of the cooperative driving maneuver can calculate the cooperative driving maneuver in such a way that the cooperative driving maneuver comprises a double lane change of the transportation vehicle to the left, if the driving intention on the part of the transportation vehicle comprises a lane change to the left, for example, to facilitate the Single lane change to the left of the requesting transportation vehicle. This allows, for example, a traffic flow to be increased and braking by one or both of the road users to be prevented.

Exemplary embodiments also create a device for a transportation vehicle. The device is designed for initiating a cooperative driving maneuver by providing a driving intention message for transportation vehicles in an environment of the transportation vehicle. The driving intention message comprises information about an intention of a driver, or an at least partially automatic transportation vehicle control system, of the transportation vehicle to carry out driving maneuvers. The device comprises an interface, designed to obtain information about a driving intention. The driving intention is based on the desire of the driver to carry out the driving maneuver. The device also comprises a positioning module, designed to determine a position of the transportation vehicle. The device also comprises a control module which is designed for controlling the interface, the positioning module and a vehicle-to-vehicle interface. The control

module is also designed to determine the driving intention message, based on the information about the driving intention. The control module is also designed to calculate transmission parameters for the driving intention message. The transmission parameters comprise a repetition rate and a time of transmission. The control module is designed to calculate the transmission parameters based on a desired reception probability of the driving intention message, the driving intention and the position of the transportation vehicle. The control module is also designed to provide the driving intention message as a direct vehicle-to-vehicle message via the vehicle-to-vehicle interface for the transportation vehicles in the environment of the transportation vehicle based on the transmission parameters.

Examples also create a device for a transportation vehicle, for carrying out a cooperative driving maneuver. The device comprises a vehicle-to-vehicle interface, designed to obtain a driving intention message from a requesting transportation vehicle. The driving intention message comprises information about an intention of a driver, or of an at least partially automatic transportation vehicle control system, of the transportation vehicle to carry out a driving maneuver. The vehicle-to-vehicle interface is also designed to receive one or more further driving intention messages from transportation vehicles in an environment of the transportation vehicle. The one or more further driving intention messages comprise information about one or more driving intentions of the transportation vehicles in an environment of the transportation vehicle. The device also comprises a control module which is designed for controlling the vehicle-to-vehicle interface and an interface. The control module is also designed for calculating the cooperative driving maneuver based on the driving intention message of the requesting transportation vehicle and on the one or more further driving intention messages of the transportation vehicles in an environment of the transportation vehicle. The calculation of the cooperative driving maneuver comprises checking whether the cooperative driving maneuver is compatible with the one or more driving intentions of the transportation vehicles in an environment of the transportation vehicle. The method is also designed for providing a driving assistance for executing the cooperative driving maneuver via the interface, provided the cooperative maneuver is compatible with the one or more further driving intention messages of the transportation vehicles in an environment of the transportation vehicle.

Exemplary embodiments also create a transportation vehicle comprising at least one of the devices. In addition, exemplary embodiments create a system comprising a transportation vehicle equipped with a device for initiating a cooperative driving maneuver and further comprising another transportation vehicle equipped with a device for carrying out a cooperative driving maneuver. Exemplary embodiments also create a program with a program code for implementing at least one of the methods when the program code is executed on a computer, a processor, a control module or a programmable hardware component.

Various exemplary embodiments will now be described in more detail with reference to the accompanying drawings, in which several exemplary embodiments are shown. In the figures, the thickness dimensions of lines, layers and/or regions are shown exaggerated for the sake of clarity.

In the following description of the attached figures, which only show some exemplary examples, the same reference numerals can be used to designate identical or equivalent components. In addition, collective reference numerals can be used for components and objects, which occur multiple

times in at least one exemplary embodiment or in a drawing, but which are described together in relation to one or more features. Components or objects described with the same or collective reference numerals can be embodied in the same way in terms of individual, multiple or all features, for example, in terms of their dimensions, but may also be embodied differently, unless otherwise explicitly or implicitly given by the description.

Although exemplary embodiments can be modified and amended in different ways, the exemplary embodiments shown in the figures are examples and are described in detail herein. It should, however, be made clear that it is not intended to restrict exemplary embodiments to the disclosed forms, but that instead exemplary embodiments should cover functional and/or structural modifications, equivalents and alternatives which lie within the field of the disclosure. Identical reference numerals designate the same or similar elements throughout the description of the figures.

It is important to note that for any element, which is designated as being “connected” or “coupled” to any other element, it can either be directly connected or coupled to the other element or else intervening elements may be present. If on the other hand, an element is designated as being “directly connected” or “directly coupled” to another element, then there are no intervening elements present. Other terms used to describe the relationship between elements should be interpreted in a similar way (e.g., “between” compared to “directly between”, “adjacent” compared to “directly adjacent”, etc.).

The terminology used herein is used only for the description of certain exemplary embodiments and is not intended to restrict the exemplary embodiments. As used herein, the singular forms “a” and “an” and “the/this” are also meant to include the plural forms, unless the context clearly indicates otherwise. In addition, it should be clarified that the expressions such as “contains”, “containing”, “has”, “comprises”, “comprising” and/or “having” as used herein, indicate the presence of cited features, whole numbers, operations, work processes, elements and/or components, but do not exclude the presence or addition of one more or one or a plurality of features, whole numbers, operations, work processes, elements, components and/or groups thereof.

Unless otherwise defined, all of the terms used herein (including technical and scientific terms) have the same meanings as would be ascribed to them by an average person skilled in the art in the field to which the exemplary embodiments belong. It should also be clarified that expressions, such as those that are defined in commonly used dictionaries, are to be interpreted as if they had the meaning consistent with their meaning in the context of the relevant technology and should not be interpreted in an idealized or overly formal sense, unless this is expressly defined herein.

Cooperative driving designates a behavior in road traffic, in which the road users enable, facilitate or support mutually planned maneuvers by appropriate adaptation of their own driving behavior. For example, cooperation can take place between different types of transportation vehicles (cars, commercial vehicles, motorcycles, etc.). A cooperative maneuver involves two roles: that of the road user who asks for a cooperation/requests a cooperation, such as creating a gap for lane changing/merging, and that of the road user who fulfills the request/accepts the request and, for example, creates a suitable gap.

The idea of at least some exemplary embodiments is to send, in addition to the already standardized V2X messages (Cooperative Awareness Message (CAM, periodic status message of the transportation vehicle), Decentralized Envi-

ronmental Notification Message (DENM, event-based message), Basic Safety Message (BSM, elementary safety message), Signal Phase and Timing message signal, (SPAT)), explicit intention messages, on the basis of which the cooperative behavior can be implemented. In cooperative 5 maneuvers it is always helpful if the intention of the transportation vehicles is known. Among other things, for the transportation vehicles which are potentially eligible for the Accept role, a driving intention message facilitates the decision as to whether they should respond to the request (relevance assessment), as well as the implementation of the cooperative maneuver itself.

As an example, in FIG. 2 a transportation vehicle **2002** is shown, which would intends to enter a freeway and merge into the traffic. To this end, it sends a driving intention 15 message, for example, to the transportation vehicles **2004** in the environment, which message comprises an intention to merge into a traffic gap **2100**. The transportation vehicles **2004** in the environment can be designed to receive the driving intention message and to actively or passively enable a cooperative maneuver based on the driving intention message.

FIG. 1 illustrates a flow diagram of an exemplary embodiment of a method for initiating a cooperative driving maneuver by providing a driving intention message for transportation vehicles in an environment of a transportation vehicle **100**. The driving intention message comprises information about an intention of a driver, or an at least partially automatic transportation vehicle control system, of the transportation vehicle **100** to carry out a driving maneuver. FIG. 1a illustrates a block diagram of an exemplary embodiment of a device **10** which is designed to implement the method.

In some exemplary embodiments, the driving intention message can comprise information on a projected trajectory of the projected driving maneuver, for example, as a time- 35 position specification or as a specification of a target range of the driving intention.

The driving intention can comprise, for example, information about a future intention to merge, a future intention to overtake, or a future intention to turn off on the part of the transportation vehicle **100**. Driving intentions can also include, for example, a lane change, a merging, a parking operation, pulling out from a parking space, or an allocation of road area to maneuvering.

For example, the information about the driving intention can comprise information about at least one intention from the set of Single lane change to the left, Single lane change to the right, Double lane change to the left, Double lane change to the right, Triple lane change to the left, Triple lane change to the right, Turning left, Turning right, Pulling out 50 from parking space and Parking the transportation vehicle. The driving intention can accordingly comprise, for example, at least one element from the set of Single lane change to the left, Single lane change to the right, Double lane change to the left, Double lane change to the right, Triple lane change to the left, Triple lane change to the right, Turning left, Turning right, Pulling out from a parking space and Parking the transportation vehicle.

In at least some exemplary embodiments the transportation vehicle **100** could correspond, for example, to an agricultural vehicle, a road vehicle, a car, a motor vehicle or a heavy goods vehicle.

The at least partially automatic transportation vehicle control system can correspond, for example, to a control unit of an automatically driven transportation vehicle, a control unit of a lane change assistant, or a control unit of an adaptive distance-regulating cruise control system.

The method comprises obtaining **110** information about a driving intention. The driving intention is based on the intention to carry out the driving maneuver. The device **10** comprises an interface **12**, designed to obtain **110** the information about the driving intention. The interface **12** and an interface **26** of FIG. 3a, can correspond, for example, to one or more inputs and/or one or more outputs for receiving and/or transmitting information, for example, in digital bit values, based on a code, within a module, between modules, or between modules of different entities. For example, the information about the driving intention can comprise a textual or coded representation of the driving intention, for example, as a bit vector, as a bit-code or as one or more coded driving maneuvers. The driving intention can be based, for example, on patterns of driving intentions. For example, can correspond for example, to a representation of the driving maneuver based on a pattern. The information about the driving intention can comprise, for example, a reference to the pattern used and information about parameters of the pattern, for example, a speed, target position, etc. For example, patterns can be used that correspond to the intentions. For example, one or more patterns can be defined for a given intention. For example, the operation of obtaining **110** can be derived from the fact that no traffic gap was identified in an upstream process to implement the driving maneuver.

The method further comprises determining **120** a position of the transportation vehicle **100**. The device **10** comprises a positioning module **14**, designed to determine the position of the transportation vehicle. In exemplary embodiments, the positioning module **14** can be implemented as any component which allows calculation or determination of information relating to a position of the device or of the positioning module **14**. Examples of conceivable components are receivers for satellite-based navigation systems, for example, a GPS receiver (Global Positioning System), or else other components which allow a position determination, for example, via triangulation of received radio signals. The position of the transportation vehicle **100** can comprise, for example, an absolute position of the transportation vehicle **100**, for example, as a length and width measurement or as GPS coordinates, or a relative position of the transportation vehicle, for example, relative to coordinates of the digital map.

The method also comprises determining **130** the driving intention message, based on the information about the driving intention. The driving intention message can be based, for example, on a communication protocol, for example, on a communications protocol of a vehicle-to-vehicle communication system. In some exemplary embodiments, the determination **130** of the driving intention message can also be based on the position of the transportation vehicle **100**. The driving intention message may also comprise, for example, information about the position of the transportation vehicle **100** and/or information about a driving lane currently being used by the transportation vehicle **100**. For example, the driving intention can also be adapted based on the position. For example, the determination **130** of the driving intention message **130** can also assign the driving intention a position, for example, a position relative to the transportation vehicle **100** or an absolute position, at which the driving intention can be implemented, for example, as a driving maneuver.

In an exemplary implementation the driving intention message has a header which can comprise checking or control data, and containers which can comprise content data, with information on the intention (Request Containers

and Accept Containers) and a container with information on the maneuver itself (Maneuver Information Container). A driving intention message with a request container can correspond, for example, to the driving intention message from FIG. 1, a driving intention message with an accept container can correspond, for example, to a message about an acceptance of the cooperative driving maneuver from FIG. 1b.

The header can a protocol version and a message identification (also Message ID), which can be implemented similarly to that used in CAM, as well as a session identification (or Session ID). The session ID can prevent ambiguities and in a cooperative maneuver can facilitate the relevance filtering and the maneuver planning. It can be retained until no more messages are sent to the maneuver according to the transmission rules valid for the maneuver. A new session ID can be used for a new maneuver.

The session ID can be generated, for example, according to specified rules. These can be defined, for example, such that no identical session ID may be used in the environment of the maneuver (uniqueness requirement), and that the session ID cannot be used for tracking transportation vehicles (privacy requirement), roughly similar to pseudonym certificates. The algorithm used to generate the session ID could contain, for example, the transportation vehicle pseudonym, the start time of the session, a random number and a hash function.

The request container can transfer information about the planned maneuver (the driving intention), for example, as a defined, function-dependent key. The request container can comprise, for example, information about the driving maneuver (a type of the driving maneuver), for example, about a single lane change to the left, a single lane change to the right, a double lane change (cutting across) to the left, a double lane change (cutting across) to the right, a triple lane change (cutting across) to the left, a triple lane change (cutting across) to the right, turning off to the left, turning off to the right, pulling out from a parking space and/or parking. The request container can also comprise information about a current driving lane of the transportation vehicle **100**, for example, a number of the driving lane (also a part of CAM and BSM), whether it is an on-ramp/acceleration lane and/or a lay-by/bus stop, a position of the transportation vehicle (also part of CAM) and/or a length of the transportation vehicle, such as the length of a single transportation vehicle or the length of a car/trailer combination.

The Accept container can comprise, for example, information about the acceptance of the cooperative driving maneuver, information on the type of the intended maneuver (such as creating a traffic gap with the required size, change of lane to the left, change of lane to the right), and/or information about an acknowledgment of receipt.

In at least some exemplary embodiments, as shown in FIG. 1b, the method can also comprise calculating **125** information about a planned implementation of the driving maneuver, based on the position of the transportation vehicle. For example, the calculation **125** can comprise calculating a first possible, a desired and/or a last possible time for the change of lane, and a prediction of an estimated speed of the transportation vehicle **100** and an estimated change of position of the transportation vehicles in an environment of the transportation vehicle **100**. The information about the planned implementation of the driving maneuver can comprise, for example, information about at least one element of the set of first possible lane change point, planned lane change point, last possible lane change point, and phase of the driving maneuver. The driving

intention message may also comprise the information about the planned implementation of the driving maneuver. For example, a driving maneuver can comprise one or more phases, for example, at least one element of the set of planning stage, waiting phase, one or more partial driving maneuvers, and a final phase.

The maneuver information container, which can correspond, for example, to a piece of information about a planned implementation of the driving maneuver, can comprise, for example, information on the planned implementation of the maneuver (e.g., planned lane change point (geospatial coordinates of the calculated lane change point and the calculated period until this lane change point)), information about the phases of a maneuver (maneuver progress), and/or boundary conditions of the maneuver, which must be complied with by the transportation vehicle (for example, first possible lane change point (geospatial coordinates of the first possible lane change point and period until this lane change point). "First possible" here means: the earliest lane change point due to the structural circumstances), and, for example, information about a termination of a driving maneuver.

In accordance with its role in a cooperative driving maneuver, a transportation vehicle can send the request or accept container. The driving intention message can be sent, for example, as a separate message or else integrated in the status message (CAM or BSM), where a part of the information is already included (e.g., transportation vehicle length, driving lane, turn signal status).

The method also comprises calculating **140** transmission parameters for the driving intention message. The transmission parameters comprise a repetition rate and a time of transmission. The calculation **140** of the transmission parameters can be based, for example, on a desired reception probability of the driving intention message, the driving intention and the position of the transportation vehicle. For example, the calculation **140** can comprise obtaining information about location-dependent transmission parameters. The information about the location-dependent transmission parameters can be based, for example, on at least one element of the set of signal strength, received signal strength, error rate, transmission probability, reception probability, information about an influence of a route guidance system on the direct vehicle-to-vehicle communication, information about static and/or mobile obstacles for a direct vehicle-to-vehicle communication between different points on a section of road and/or comprise at least one element of the set. In at least some exemplary embodiments, the information about the location-dependent transmission parameters can comprise one or more sets/groups of transmission parameters, for example, settings for transmit/receive units, related for example, to the transmission gain or a pre-distortion, and/or settings at the protocol level, which indicate a repetition rate, for example. Alternatively or additionally, the information about the location-dependent transmission parameters can comprise measurement results of received signals or data that are based on one or a plurality of sets of sending parameters. Based on the information about the location-dependent transmission parameters, the calculation **140** can determine transmission parameters for the current position of the transportation vehicle.

For example, the calculation **140** of the transmission parameters can be based on the driving intention: for example, different driving intentions can require different transmission parameters. For example, the calculation **140** can be based on the direction in which, for a particular driving intention, transportation vehicles can be located in

the environment for which the driving intention is relevant, for example, if the transportation vehicle **100** is designed (for example, by the vehicle-to-vehicle interface **18**) to provide the driving intention message to a specific target.

For example, the calculation **140** can compute the repetition rate for the transmission parameters. For the repetition rate of the intention message, for example

1. a fixed value can be specified (such as in BSM) or
2. the transmission rate can be adjusted dynamically (such as in CAM). In the case of dynamic adjustment either of these is possible:
 - a. it is performed based on the CAM standard or
 - b. separate rules are used for sending an intention message.

In at least one disclosed design, the repetition rate of the intention messages can be dynamically specified by the calculation **140** such that at a specified distance a minimum reception probability, to be defined, of the intention messages is reached. With increasing repetition rate the reception probability usually increases, since it is a cumulative reception probability.

The distance to be defined can be selected, for example, such that the potentially cooperating road users receive intention messages sufficiently early that a relevance assessment and the implementation of the cooperative maneuver is possible. Therefore, the distance associated with a reception probability (e.g., 99%) to be defined depends on the type of intention (e.g., merging, parking), on the cooperative maneuver (lane change, deceleration), on the traffic situation (e.g., inner-city 30 mph zone, highway without speed restriction), on the traffic density, among others. The calculation **140** of the transmission parameters can be based, for example, on at least one element of the set of type of intention, type of cooperative maneuver, traffic situation and traffic density.

The probability that intention messages sent by the transportation vehicle **100** (and other types of messages) are received at a specific distance from other road users often depends on the location (shading by buildings, hills, forest, etc.). It can be estimated, for example, from an observation of the radio channel or be based on location-dependent transmission parameters. For example, the reception probability can be determined by measurement techniques and be available from a digital map, for example, contained in the information about the location-dependent transmission parameters.

In a further disclosed design, the repetition rate of the intention messages is dynamically adjusted to the procedure of the cooperation maneuver. If two cooperation partners have met for a cooperative maneuver and a request driving intention message has been provided **150** (FIG. 1), and a message about an acceptance of the cooperative driving maneuver has been received **155** (FIG. 1b) (Accept driving intention message), the repetition rate of the intention messages can be reduced, for example, if the cooperation partners are located close together in space. For example, on a highway on-ramp, if the cooperation partners are still far apart from each other the repetition rate can be higher. If the merging operation takes place and one of the cooperation partners is driving almost right behind the other, the repetition rate can be lower. The reduction of the repetition rate can take place, for example, in a location-dependent or distance-dependent way according to a specified algorithm, which in at least one exemplary embodiment takes the distance and the relative speeds of the cooperation partners as inputs, e.g., linear reduction of the repetition rate from the start value to a value to be defined (e.g., 2 Hz).

A period of validity of a driving intention message can end, for example, on receipt of a further driving intention message with the same session ID, or if no further message is received after a specified lifetime (the value can depend on the transmission rate, for example).

The method also comprises providing **150** the driving intention message as a direct vehicle-to-vehicle message for the transportation vehicles in the environment of the transportation vehicle **100** based on the transmission parameters.

The device **10** comprises a control module **16**, which is designed for controlling the interface **12**, the positioning module **14** and a vehicle-to-vehicle interface **18**. The control module **16** is designed to determine **130** the driving intention message based on the information about the driving intention, to calculate **140** the transmission parameters and to provide **150** the driving intention message via the vehicle-to-vehicle interface **18**. The control module **16** is coupled to the interface **12**, the positioning module **14** and the vehicle-to-vehicle interface **18**. In at least some exemplary embodiments the control module **16** can be designed to implement the process operations at **110-160**, for example, using the interface **12**, the positioning module **14** and/or the vehicle-to-vehicle interface **18**.

In exemplary embodiments, the control device or control module **16**, and a control module **24** from FIG. 3a, can correspond to any controller or processor or a programmable hardware component. For example, the control module **16**; **24** can also be implemented as software which is programmed for a corresponding hardware component. In this respect, the control module **16**; **24** can be implemented as programmable hardware with appropriately adapted software. Any type of processors, such as digital signal processors (DSPs), can be used for this. Exemplary embodiments are not restricted to a specific type of processor. Any number of processors or even a plurality of processors is conceivable for the implementation of the control module **16**; **24**.

A direct vehicle-to-vehicle communication for providing **150** the driving intention message can be carried out, for example, via a vehicle-to-vehicle interface, such as the vehicle-to-vehicle interface **18** of the device **10**. The provision **150** of the driving intention message can take place, for example, via a shared communication channel (shared channel, broadcast channel). In some exemplary embodiments, the provision **150** can be carried out via a direct vehicle-to-vehicle communication by a direct wireless communication link between two transportation vehicles, for example, without the use of a base station, for example, in accordance with IEEE 802.11p (a standard of the Institute of Electrical and Electronics Engineers). The vehicle-to-vehicle interface **18** and a vehicle-to-vehicle interface **22** from FIG. 3a can be designed, for example, to communicate directly with other transportation vehicles in an environment by wireless. The vehicle-to-vehicle interface **18**; **22** can be designed, for example, for a direct vehicle-to-vehicle communication and comprise one or more inputs and/or one or more outputs for receiving and/or transmitting information, for instance, in digital bit values, between different transportation vehicles. Alternatively or additionally, the vehicle-to-vehicle interface **18**; **22** can be designed to use a transportation vehicle light, for example, a transportation vehicle light directed in the direction of travel or in the direction opposite to the direction of travel (front headlights, daytime running lights for traffic driving ahead and tail lights for following traffic), to provide a vehicle-to-vehicle communication using information modulated on to the light beam. Camera systems in the front/rear section or appropriate light sensors are conceivable as receivers.

The provision **150** can be, for example, the beginning of the exemplary communication protocol described in the following.

A request driving intention message can correspond to the driving intention message of FIG. **1** and/or FIG. **3**. If corresponding trigger conditions are met, the transportation vehicle which requests a cooperation, such as a requesting transportation vehicle **100** from FIG. **1** or **3**, can send a request driving intention message with a filled request container and driving maneuver container (optional) and with an empty accept container. The driving intention message can be sent, for example,

1. up to the completion of the cooperative driving maneuver or
2. if no maneuver is implemented, until a cooperation is no longer relevant, for example, because in the meantime the intended maneuver can be carried out without cooperation partners.

In some exemplary embodiments, as shown in FIG. **1b**, the method can also comprise receiving **155** a message about an acceptance of the cooperative driving maneuver as a response to the driving intention message, from at least one of the transportation vehicles in the environment of the transportation vehicle, for example, by the control module **16** via the vehicle-to-vehicle interface **18**. The message about the acceptance of the cooperative driving maneuver can indicate, for example, that at least one transportation vehicle is ready to carry out the cooperative driving maneuver. The calculation **140** of the transmission parameters can also be based on the message about the acceptance of the cooperative driving maneuver. For example, the transmission parameters can be based on a position or an identification of a transportation vehicle which provided the message about the acceptance. For example, the method can also comprise determining a distance of the at least one transportation vehicle or its position, and these can be used to adjust a repetition rate, a transmission power or a transmission direction using the transmission parameters.

It can be useful in some cases to carry out a direct consultation of the cooperation partners to validate the driving maneuver. In this case, a possible response of the transportation vehicle **100** to the message about the acceptance of the cooperative driving maneuver of the cooperating transportation vehicle can be a confirmation (or Acknowledge) message. The control module **16** can be designed to send, in addition to the request container, an accept container with the acknowledgment message. This can be carried out, for example, as long as request containers are being sent.

It is conceivable that situations will occur which require the planned cooperative maneuver to be aborted, for example, transportation vehicles in front of the accept transportation vehicle force it to brake so it cannot generate the planned gap. In this case, the accept transportation vehicle can be configured to suspend the sending of a message about acceptance of the cooperative driving maneuver, or to provide messages with an empty accept container and the abort information in the maneuver information container. The abort intention message can be sent, for example, with a fixed number of repetitions (e.g., 5 times). In some exemplary embodiments, no further messages are then sent by the accept transportation vehicle about acceptance of the cooperative driving maneuver.

In the event that the transportation vehicle **100** no longer wishes to or cannot carry out the planned co-operative maneuver, the control module **16** can be designed, for example, to suspend the provision of driving intention

messages or to provide a maneuver abort message with the specified number of repetitions.

In at least some exemplary embodiments, the method can also comprise implementation **160** of the cooperative driving maneuver, for example, based on the driving intention message and based on the message about the acceptance of the cooperative driving maneuver. The implementation **160** can comprise, for example, at least one element of the set of providing a speed-time curve for an adaptive cruise control system, providing a longitudinal and/or transverse control assistance, triggering an automated lane change, and providing parameters for an at least partially automatic driving control system.

The implementation **160** can also comprise providing a control signal for controlling the braking, acceleration or lane change functionalities, for example, via an interface, such as a Controller Area Network Bus (CAN bus) of the transportation vehicle **100**.

The implementation **160** can correspond, for example, to an automated execution of the driving maneuver, for example, via a driver assistance system or by adaptation of an automatically driven transportation vehicle. Alternatively or additionally, the implementation **160** can correspond to provision of instructions for implementing the driving maneuver for a driver of the transportation vehicle **100** via a human-machine interface. The human-machine-interface can be, for example, a screen, a projector or an audio output module. The instructions can be, for example, spoken instructions, audio signals and/or visual representation of the instructions.

In some exemplary embodiments, the implementation **160** can also comprise a longitudinal control and/or a transverse control, based on the driving intention messages and status messages, of the at least one other transportation vehicle, environment information of the at least one other transportation vehicle and/or sensor data of the transportation vehicle **100**.

FIG. **3** illustrates a flow diagram of an exemplary embodiment of a method for a transportation vehicle **200** for implementing a cooperative driving maneuver. FIG. **3a** illustrates a block diagram of an exemplary embodiment of a device **20** for the transportation vehicle **200** for implementing a cooperative driving maneuver, designed for executing the method.

The method comprises obtaining **210** a driving intention message from a requesting transportation vehicle **100**. The driving intention message comprises information about an intention of a driver, or an at least partially automatic transportation vehicle control system, of the transportation vehicle **100** to implement a driving maneuver. The reception **210** can be performed, for example, by vehicle-to-vehicle communication, for example, via a vehicle-to-vehicle interface **22** of the device **20**, which is designed for vehicle-to-vehicle communication. The device also comprises a control module **24**, designed for receiving **210** via the vehicle-to-vehicle interface **22**. The vehicle-to-vehicle interface **22** is coupled to the control module **24**. The device also comprises an interface **26** which is coupled to the control module **24**.

The method also comprises receiving **212** one or more additional driving intention messages of transportation vehicles in an environment of the transportation vehicle **200**. The one or more further driving intention messages comprise information about one or more driving intentions of the transportation vehicles in an environment of the transportation vehicle **200**. The driving intention messages can be implemented, for example, similarly to the driving intention message of the requesting transportation vehicle **100**. The

control module **24** is designed for receiving **212** via the vehicle-to-vehicle interface **22**.

The method also comprises calculation **216** of the cooperative driving maneuver, based on the driving intention message of the requesting transportation vehicle **100** and on the one or more further driving intention messages of the transportation vehicles in an environment of the transportation vehicle **200**. The control module **24** is designed for calculating **16**. The calculation **216** comprises checking **218** whether the cooperative driving maneuver is compatible with the one or more driving intentions of the transportation vehicles in an environment of the transportation vehicle **200**. For example, the calculation **218** can check whether a possible lane change point is compatible with the one or more driving intentions, which in some exemplary embodiments can already be carried out. For example, this may be based on a piece of information about the progress of the driving maneuver (phase). In some exemplary embodiments, the checking operation at **218** can also be based on sensor data of the transportation vehicle **200**. The checking operation at **218** may also comprise capturing a traffic situation, based on the sensor data. The checking operation at **218** can also verify whether the planned driving maneuver is compatible with the traffic situation. The sensor data can comprise, for example, camera sensor data, radar sensor data, lidar sensor data or propagation time sensor data.

In some exemplary embodiments the calculation **216** can comprise, for example, determining **220** a piece of information about a cooperation in a cooperative driving maneuver with the requesting transportation vehicle **100**. The information about the cooperation can indicate whether the transportation vehicle **200** is eligible as a cooperation partner and whether a cooperative behavior is possible given the traffic situation, based on the driving intention message. In some exemplary embodiments it may also be checked/displayed whether the cooperative behavior is possible based on further restrictions.

The determination operation at **220** as a relevance assessment can check, for example, in a plurality of operations, whether the receiving transportation vehicle is eligible in principle as a cooperation partner and whether a cooperative behavior is possible, taking into account the traffic situation as well as possible further restrictions. These restrictions result, for example, from the limits of the driver's readiness to co-operate and from other goals, such as an efficient driving. For example, the determination operation at **220** can be based on information about a driving behavior of a driver of the transportation vehicle **200**. The method can also comprise determining the information about the driving behavior, for example, to determine a driving dynamics or a probability of overtaking for the driver.

For example, the driver could specify the maximum permissible deceleration when increasing the size of gaps using the information about the driving behavior. This could derive the determination of the driving dynamics from its driver's experience, according to the facility of an ACC to configure the distance to the transportation vehicle in front within certain limits. It could also be determined whether driving lane changes are allowed to be considered for a cooperative maneuver or not.

In some exemplary embodiments, for example, the calculation **216** can also comprise determining **230** information about a driving maneuver for planning a maneuver. The information about the driving maneuver can comprise, for example, a trajectory of a driving maneuver, for example, as a time-position chain. In at least some exemplary embodiments the maneuver planning also takes place in several

operations. The determination operation at **230** can comprise, for example, determination **232** of information about at least one distance to a transportation vehicle in front and/or to a following transportation vehicle, to enable a calculation of whether the desire to change lanes can be met in a possible cooperation area. The determination operation can calculate, for example, the extent to which the distance to its leading transportation vehicle and, if appropriate, also to its following transportation vehicle, can be adjusted for a lane change maneuver at the current driving speed. If the length of the request transportation vehicle (and any trailer, etc.) is transmitted, for example, in the driving intention message or by status messages of the request transportation vehicle, in some exemplary embodiments this can be taken into account.

In some exemplary embodiments the determination operation at **230** also comprises an identification **234** of an execution of the driving maneuver, based on the information about the driving maneuver, the information about the at least one distance, a speed of the transportation vehicle **205** and a distance to the possible cooperation area. On the basis of the result of the previous operations, taking into account its speed and the distance to the possible cooperation area, the identification operation at **234** can identify which implementation of the driving maneuver (e.g., delay-time curve) would be necessary for the cooperation.

In some exemplary embodiments the determination operation at **230** also comprises calculating **236** whether the driving maneuver is possible, taking into account the traffic situation (and, for example, further restrictions). In the event of a negative test outcome, the maneuver planning may be aborted.

The method further comprises providing **240** a driving assistance for implementing the cooperative driving maneuver via the interface **26**, provided the cooperative maneuver is compatible with the one or more further driving intention messages of the transportation vehicles in an environment of the transportation vehicle **200**.

The provision **240** of the driving assistance can correspond, for example, to an automated execution of the driving maneuver, for example, via a driver assistance system or by adjustment of an automatically driven transportation vehicle. Alternatively or additionally, the provision **240** can correspond to a provision of instructions for implementing the driving maneuver for a driver of the transportation vehicle **240** via a human-machine interface. The human-machine-interface can be, for example, a screen, a projector or an audio output module. The device **20** can comprise, for example, the human-machine interface. The instructions can be, for example, spoken instructions, audio signals and/or visual representation of the instructions.

In some exemplary embodiments, the provision operation at **240** can also comprise a longitudinal control and/or a transverse control, based on the driving intention messages and status messages of the at least one other transportation vehicle, environment information of the at least one other transportation vehicle and/or sensor data of the transportation vehicle **200**.

Depending on the degree of automation, the transportation vehicle **200** can perform the planned maneuver automatically, the provision **240** can also inform the driver via a suitable HMI, or in the case of manual operation of the transportation vehicle it can prompt the driver to implement the cooperative maneuver. In addition, it can provide **240** appropriate instructions via a corresponding HMI.

The provision **240** may also comprise providing a message about an acceptance of the lane change request for the

requesting transportation vehicle **100** and the at least one other transportation vehicle **200** (Accept message).

Transportation vehicles which receive request intention messages can carry out, for example, a relevance assessment, for instance, by obtaining **220** information about cooperation in a cooperative driving maneuver. An example of an item to be assessed is whether they qualify as potential cooperation partners. Example criteria are whether they are located on the driving lane concerned, whether cooperative maneuvers are possible for them at all, etc. In the event of a negative relevance assessment the received request message may be discarded and further request messages with this session ID ignored. In some cases, no response is then made to the request (no answer).

In the event of a positive relevance assessment a feasibility assessment can be carried out, for instance, by determining (**230**) information about a driving maneuver (FIG. **3b**). In some exemplary embodiments, it can be verified that

1. no other transportation vehicle is already sending an Accept intention message with this session ID (uniqueness of the cooperation partners involved) and
2. no conflicts occur with other cooperative maneuvers already planned (with a different session ID). This requires, among other things, an analysis of the spatial arrangement of the various cooperation pairs relative to each other and a check of whether the “choreography” of the cooperation processes is possible without a collision.

In the case of a positive feasibility assessment an intention message with Accept container can be sent, which can comprise the Accept and the type of the proposed maneuver (create gap with the required size, change of lane). The Accept intention message in some exemplary embodiments is sent

1. up to the completion of the cooperative maneuver or
2. until the cooperative maneuver is aborted

For reasons of uniqueness, in some exemplary embodiments only one cooperative maneuver can be processed by a transportation vehicle. The control module **24** can be designed, for example, not to send Accept intention messages relating to more than one session at the same time.

In some exemplary embodiments, as shown in FIG. **3b**, the method can also comprise obtaining **214** information about the transportation vehicle's **200** own driving intention. This can be implemented, for example, in a similar way to the obtaining operation at **110**. The calculation **216** can also be based on the information about the transportation vehicle's own driving intention, for example, the transportation vehicle's own driving intention can be used analogously to the one or more other driving intentions. Alternatively or in addition to checking the compatibility of the driving intentions of the driving intention message and the additional driving intention messages, the checking operation at **218** can check whether the cooperative maneuver is compatible with the transportation vehicle's own driving intention. The provision **240** can also be based on whether the cooperative driving maneuver is compatible with the transportation vehicle's own driving intention.

In at least one exemplary embodiment the driving maneuver can be a Single lane change maneuver to the left. If the transportation vehicle's **200** own intention comprises a driving lane change to the left, then the calculation operation at **216** can calculate the cooperative maneuver in such a way that the cooperative driving maneuver comprises a double lane change of the transportation vehicle (**200**) to the left, for example, to enable the single lane change to the left of the requesting transportation vehicle **100**.

FIG. **4a** shows an overview of the exemplary embodiment. Three Vehicles A **4002**, B **4004**, C **4006** are driving one behind the other. The velocities behave as follows: $V_a < V_b < V_c$. Both B **4004** and C **4006** are planning an overtaking maneuver. This situation often occurs, for example, on freeways if a transportation vehicle B **4004** with a trailer overtakes a truck A **4002** and in doing so must take into account the faster, following traffic C **4006**.

It would be beneficial if C **4006** had knowledge of the overtaking intention and is prepared to move out of the way, for example, onto a third lane. In addition, it would be beneficial if C **4006** could have knowledge of the planned overtaking maneuver in good time, to react accordingly. In the ideal case, the overtaking maneuver of B **4004** and C **4006** could be automatically synchronized and implemented.

FIG. **4b** shows another overview of the system. A **4002**, B **4004** and C **4006** are transportation vehicles with different speeds, **4002a**, **4004a** and **4006a** are antennas of a car-2-car communication system, **4008** and **4010** communication paths between the transportation vehicles, **4012** is a planned path of the overtaking operation of B, **4014** is a planned path of the overtaking operation of C, which could lead to a collision with B, **4016** is a path of the overtaking operation of C, with knowledge of the overtaking intention of B, and **4018** is a rear-facing sensor device. This can comprise, for example, a camera, a light sensor, a radar system, a LIDAR system, or an ultrasonic sensor. **4020** shows a frontal sensor device. This can comprise, for example, a camera, a light sensor, a radar system, a LIDAR system or an ultrasonic sensor. **4022** shows a communication path in which a transportation vehicle communicates the fact a transportation vehicle is speeding ahead of it. The transportation vehicle in question is additionally provided with a processing unit for evaluating the sensor devices (for example, the control module **16** or **22**) and the communication data, and an HMI interface for interaction with the driver. The HMI allows the driver, for example, to signal an overtaking request and to receive a feedback message as to whether the following traffic will allow the overtaking maneuver. The detection of an overtaking request as a driving intention can in some exemplary embodiments be based on the detection of typical preparatory actions, such as head/eye movements in the direction of door or rear-view mirrors, downshifting, tailgating, accelerating, setting the turn indicator, etc.

In one exemplary implementation the transportation vehicle can be designed, for instance, in the determining operation at **220**, to create an environment model on the basis of the available data from different sources (vehicle-to-vehicle communication, online data, GPS, camera data, LIDAR data, propagation time sensors). The data can originate from the following sources, for example:

- online data about traffic density, position of other transportation vehicles
- position of the transportation vehicle from vehicle-to-vehicle messages, status and driving vectors of transportation vehicles in the vicinity
- GPS own position
- Front radar distance/driving vector of preceding transportation vehicles
- Front camera distance and number plate (identification) of preceding transportation vehicles
- rear radar distance/driving vector of following transportation vehicles.
- rear camera distance and number plate (identification) of following transportation vehicles

LIDAR laser scanner, radar
vehicle-to-vehicle 802.11p tracking of transportation
vehicles via their vehicle-to-vehicle 802.11p signal
(radio tracking)

Course data

Corresponding driving intention messages can comprise
the following data, for example:

transportation vehicle identification
position
driving vector/trajectory
change of driving vector
number of preceding transportation vehicles
distance to preceding transportation vehicles
presence of traffic gaps in chain of preceding transporta-
tion vehicles
maneuvering intention
acknowledgement

A driving vector/trajectory in this context can comprise,
for example, a direction, a speed and/or a change of direc-
tion/speed. For example, a driving vector can be defined for
the planned maneuver, for example, for a desired change in
the driving vector.

In the overtaking example with the transportation vehicles
A **4002**, B **4004**, C **4006**, for example, the following
environmental image is obtained with pre-calculated drive
vectors. Both B **4004** and C **4006** are planning an overtaking
maneuver.

To avoid a collision, the following vehicle-to-vehicle
communication shown in FIG. 4c takes place between
transportation vehicles, for example:

B **4004** provides a driving intention message with an
overtaking request (single lane change) for the transporta-
tion vehicles in the environment A **4002** and C
4006

A **4002** and C **4006** locate B **4004**, for example, via a
position which is included in the driving intention
message, its identification, or by directional radio

A **4002** and C **4006** carry out a situation assessment with
a relevance assessment (e.g., by identification **220**)

Vehicle A **4002** signals to B **4004** that it is maintaining its
course and indicates a corresponding notification to the
driver

Vehicle C **4006** obtains an acknowledgment by the driver
(or makes the decision autonomously) and provides a
message about acceptance to B, which indicates to B
4004, that C **4006** will execute a double lane change
and make way

Vehicle B **4004** signals to the driver (or an automatic
transportation vehicle control system) that the way is
free and overtakes

Vehicle B **4004** signals to A **4002** and C **4006** that the
process is completed

The upshot is that A **4002**, B **4004**, C **4006** have agreed
on a joint procedure. A **4002** maintains its driving vector. B
4004 overtakes A **4002** and has coordinated this with C
4006. C **4006** overtakes also, but in doing so takes B **4004**
into consideration. B4.

In at least some exemplary embodiments the control
module **24** can be designed to execute the process operations
at **210-240**.

Another exemplary embodiment is a computer program
for implementing at least one of the methods described
above, when the computer program is executed on a com-
puter, a processor or a programmable hardware component.
Another exemplary embodiment is also a digital storage
medium, which is machine- or computer-readable, and has
electronically readable control signals, which can interact

with a programmable hardware component such that one of
the methods described above is executed.

The features disclosed can be of significance and imple-
mented both individually as well as in any desired combi-
nation to realize exemplary embodiments in their various
configurations.

Although some properties have been described in con-
nection with a device, it goes without saying that these
properties also represent a description of the corresponding
method, so that a block or a component of a device is also
to be understood as a corresponding method operation or as
a feature of a method operation. Similarly, properties that
have been described in relation to or as a method operation
also represent a description of a corresponding block or
detail or feature of a corresponding device.

Depending on the specific implementation requirements,
exemplary embodiments can be implemented either in hard-
ware or in software. The implementation can be carried out
by using a digital storage medium, such as a floppy disk, a
DVD, a Blu-Ray disc, a CD, a ROM, a PROM, or an
EPROM, EEPROM or Flash memory, a hard disk or other
magnetic or optical storage, on which electronically read-
able control signals are stored, which can interact with a
programmable hardware component, or interact in such a
way that the respective method is carried out.

A programmable hardware component can be formed by
a processor, a computer processor (CPU=Central Processing
Unit), a graphics processing unit (GPU=Graphics Process-
ing Unit), a computer, a computer system, an application-
specific integrated circuit (ASIC), an integrated circuit (IC),
a single-chip system (SOC=System-on-Chip), a program-
mable logic element or a field-programmable gate array
(FPGA) with a microprocessor.

The digital storage medium can therefore be machine- or
computer-readable. Some exemplary embodiments thus
comprise a data carrier, which has electronically readable
control signals that are capable of interacting with a pro-
grammable computer system or a programmable hardware
component, in such a way that one of the methods described
herein is carried out. At least one exemplary embodiment
therefore is a data carrier (or a digital storage medium or a
computer-readable medium), on which the program is
recorded for carrying out one of the methods described
herein.

In general, exemplary embodiments can be implemented
as software, firmware, computer program or computer pro-
gram product with a program code or as data, wherein the
program code is, or the data are, effective in terms of
carrying out one of the methods if the program is running on
a processor or a programmable hardware component. The
program code or the data can also be stored, for example, on
a machine-readable medium or data carrier. The program
code or the data can exist as source code, machine code or
byte code, among other things, as well as other intermediate
code.

Another exemplary embodiment is also a data stream, a
signal train or a sequence of signals, which represent or
represents the program for carrying out one of the methods
described herein. The data stream, the signal train or the
sequence of signals can be configured, for example, so as to
be transferred over a data communication connection, for
example, via the internet or any other network. Exemplary
embodiments are thus also signal trains representing data,
which are suitable for transferring over a network or a data
communication connection, wherein the data represent the
program.

A program in accordance with at least one exemplary embodiment can implement one of the methods during its implementation, for example, by the program reading out memory locations or writing a datum or plurality of data into these locations, which enables switching operations or other operations to be invoked in transistor structures, in amplifier structures or in other electrical, optical, magnetic components or components operating according to another functional principle. Accordingly, by reading from a memory location, data, values, sensor values or other information can be recorded, determined or measured by a program. By reading out one or more memory locations, a program can therefore detect, determine or measure variables, values, measurement variables and other information, and can also by writing to one or more memory locations perform, initiate or implement an action, and also control other equipment, machinery and components.

The examples described above only represent an illustration of the principles of the present disclosure. It is implicit that modifications and variations of the arrangements and details described herein will be apparent other persons skilled in the art. It is therefore intended that the disclosure be limited only by the scope of protection of the following patent claims and not by the specific details, which have been presented herein on the basis of the description and explanation of the exemplary embodiments.

LIST OF REFERENCE NUMERALS

- 10 device
- 12 interface
- 14 positioning module
- 16 control module
- 18 vehicle-to-vehicle interface
- 20 device
- 22 vehicle-to-vehicle interface
- 24 control module
- 26 interface
- 100 transportation vehicle
- 110 obtaining information about a driving intention
- 120 determining a position
- 125 calculating information about planned implementation
- 130 determining the driving intention message
- 140 calculating transmission parameters
- 150 providing the driving intention message
- 155 receiving message about acceptance of the cooperative driving maneuver
- 160 implementing the cooperative driving maneuver
- 200 transportation vehicle
- 210 obtaining a driving intention message
- 212 obtaining one or more other driving intention messages
- 214 obtaining information about own driving intention
- 216 calculating a cooperative driving maneuver
- 218 compatibility checking
- 220 identifying information about cooperation
- 230 determining information about driving maneuver
- 232 identifying distance
- 234 identifying an implementation of the driving maneuver
- 236 calculating whether driving maneuver possible
- 240 providing a driving assistance
- 2002 transportation vehicle
- 2004 transportation vehicles in the environment of the transportation vehicle
- 2100 traffic gap
- 4002 vehicle A
- 4002a antenna of vehicle A
- 4004 vehicle B

- 4004a antenna of vehicle B
- 4006 vehicle C
- 4006a antenna of vehicle C
- 4008 communication path between vehicle A and B
- 4010 communication path between vehicle B and C
- 4012 planned path of B
- 4014 planned path of C
- 4016 corrected path of C
- 4018 rear-facing sensor device
- 4020 frontal sensor device
- 4022 communication path

The invention claimed is:

1. A method for initiating and/or carrying out a cooperative driving maneuver by providing a driving intention message for transportation vehicles in an environment of a transportation vehicle, wherein the driving intention message comprises information about an intention of a driver or of an at least partially automatic transportation vehicle control system of the transportation vehicle to carry out a driving maneuver, the method comprising:

- obtaining information about a driving intention, wherein the driving intention is based on the intention to carry out the driving maneuver;
- determining a position of the transportation vehicle;
- determining the driving intention message, based on the information about the driving intention;
- calculating transmission parameters for the driving intention message, wherein the transmission parameters comprise a repetition rate and a time of transmission, based on a desired minimum reception probability of the driving intention message, the driving intention and the position of the transportation vehicle;
- calculating information about a planned implementation of the driving maneuver based on the position of the transportation vehicle,
- wherein the information about the planned implementation of the driving maneuver comprises information about at least one element of the set of first possible planned lane change point, last possible lane change point, and phase of the driving maneuver;
- providing the driving intention message as a direct vehicle-to-vehicle message for the transportation vehicles in the environment of the transportation vehicle based on the transmission parameters; and
- receiving a message, as a vehicle-to-vehicle message, about an acceptance of the cooperative driving maneuver in response to the driving intention message, from at least one of the transportation vehicles in the environment of the transportation vehicle, the acceptance message including an acceptance and information about an intended type of maneuver of the at least one of the transportation vehicles in the environment, wherein the calculation of the transmission parameters is additionally based on the message about the acceptance of the cooperative driving maneuver.

2. The method of claim 1, further comprising: implementing the cooperative driving maneuver, based on the driving intention message and based on the message about the acceptance of the cooperative driving maneuver.

3. The method of claim 1, wherein the determination of the driving intention message is also based on the position of the transportation vehicle, and wherein the driving intention message also comprises information about the position of the transportation vehicle and/or information about a driving lane currently being used by the transportation vehicle.

23

4. The method of claim 1, wherein the driving intention message also comprises the information about the planned implementation of the driving maneuver.
5. A method for a transportation vehicle for carrying out a cooperative driving maneuver, the method comprising: obtaining a driving intention message from a requesting transportation vehicle, wherein the driving intention message comprises information about an intention of a driver, or an at least partially automatic transportation vehicle control system, of the requesting transportation vehicle to carry out a driving maneuver; obtaining one or more further driving intention messages from transportation vehicles in an environment of the transportation vehicle, wherein the one or more further driving intention messages comprise information about one or more driving intentions of the transportation vehicles in an environment of transportation vehicle; calculating the cooperative driving maneuver based on the driving intention message of the requesting transportation vehicle and on the one or more further driving intention messages of the transportation vehicles in an environment of the transportation vehicle, wherein the calculation comprises checking whether the cooperative maneuver is compatible with the one or more driving intentions of the transportation vehicles in an environment of the transportation vehicle; calculating information about a planned implementation of the driving maneuver based on the position of the transportation vehicle, wherein the information about the planned implementation of the driving maneuver comprises information about at least one element of the set of first possible planned lane change point, last possible lane change point, and phase of the driving maneuver; receiving a message, as a vehicle-to-vehicle message, about an acceptance of the cooperative driving maneuver in response to the driving intention message, from at least one of the transportation vehicles in the environment of the transportation vehicle, the acceptance message including an acceptance and information about an intended type of maneuver of the at least one of the transportation vehicles in the environment, wherein the calculation of the transmission parameters is additionally based on the message about the acceptance of the cooperative driving maneuver, and providing a driving assistance to implement the cooperative driving maneuver provided the cooperative maneuver is compatible with the one or more further driving intention messages of the transportation vehicles in an environment of the transportation vehicle.
6. The method of claim 5, further comprising: obtaining information about a driving intention on the part of the transportation vehicle, wherein the calculation is additionally based on the information about the transportation vehicle's own driving intention, wherein the checking step additionally checks whether the cooperative maneuver is compatible with the transportation vehicle's own driving intention, and wherein the provision is additionally based on whether the cooperative maneuver is compatible with the transportation vehicle's own driving intention.
7. The method of claim 6, wherein the driving maneuver is a single lane change to the left, wherein the calculation calculates the cooperative driving maneuver so the cooperative driving maneuver comprises a double lane change of the

24

transportation vehicle to the left, in response to the driving intention on the part of the transportation vehicle comprising a lane change to the left, to facilitate the single lane change to the left of the requesting transportation vehicle.

8. A device for a transportation vehicle for initiating a cooperative driving maneuver by providing a driving intention message for transportation vehicles in an environment of the transportation vehicle, wherein the driving intention message comprises information about an intention of a driver of the transportation vehicle to carry out a driving maneuver, the device comprising:

an interface to obtain information about a driving intention, wherein the driving intention is based on the desire of the driver to carry out the driving maneuver; a positioning module for determining a position of the transportation vehicle; and

a control module for:

controlling the interface, the positioning module and a vehicle-to-vehicle-interface,

determining the driving intention message, based on the information about the driving intention,

calculating transmission parameters for the driving intention message, wherein the transmission parameters comprise a repetition rate and a time of transmission, based on a desired minimum reception probability of the driving intention message, the driving intention and the position of the transportation vehicle,

providing the driving intention message as a direct vehicle-to-vehicle message via the vehicle-to-vehicle interface for the transportation vehicles in the environment of the transportation vehicle based on the transmission parameters, and

receiving a message, as a vehicle-to-vehicle message, about an acceptance of the cooperative driving maneuver in response to the driving intention message, from at least one of the transportation vehicles in the environment of the transportation vehicle, the acceptance message including an acceptance and information about an intended type of maneuver of the at least one of the transportation vehicles in the environment,

wherein the calculation of the transmission parameters is additionally based on the message about the acceptance of the cooperative driving maneuver,

wherein information about a planned implementation of the driving maneuver is calculated based on the position of the transportation vehicle, wherein the information about the planned implementation of the driving maneuver comprises information about at least one element of the set of first possible planned lane change point, last possible lane change point, and phase of the driving maneuver.

9. The device of claim 8, wherein the cooperative driving maneuver is implemented based on the driving intention message and based on the message about the acceptance of the cooperative driving maneuver.

10. The device of claim 8, wherein the determination of the driving intention message is also based on the position of the transportation vehicle, and wherein the driving intention message also comprises information about the position of the transportation vehicle and/or information about a driving lane currently being used by the transportation vehicle.

11. The device of claim 8, wherein the driving intention message also comprises the information about the planned implementation of the driving maneuver.

25

12. A device for a transportation vehicle for carrying out a cooperative driving maneuver, the device comprising:

a vehicle-to-vehicle interface for:

obtaining a driving intention message from a requesting transportation vehicle, wherein the driving intention message comprises information about an intention of a driver, or an at least partially automatic transportation vehicle control system, of the requesting transportation vehicle to carry out a driving maneuver, and

obtaining one or more further driving intention messages from transportation vehicles in an environment of the transportation vehicle, wherein the one or more further driving intention messages comprise information about one or more driving intentions of the transportation vehicles in an environment of transportation vehicle; and

a control module for:

controlling the vehicle-to-vehicle interface and an interface, calculating the cooperative driving maneuver based on the driving intention message of the requesting transportation vehicle and on the one or more further driving intention messages of the transportation vehicles in an environment of the transportation vehicle, wherein the calculation of the cooperative maneuver comprises checking whether the cooperative maneuver is compatible with the one or more driving intentions of the transportation vehicles in an environment of the transportation vehicle,

receiving a message, as a vehicle-to-vehicle message, about an acceptance of the cooperative driving maneuver in response to the driving intention message, from at least one of the transportation vehicles in the environment of the transportation vehicle, the acceptance message including an acceptance and information about an intended type of maneuver of the at least one of the transportation vehicles in the environment,

26

wherein the calculation of the transmission parameters is additionally based on the message about the acceptance of the cooperative driving maneuver, and

providing a driving assistance to implement the cooperative driving maneuver via the interface, provided the cooperative maneuver is compatible with the one or more further driving intention messages of the transportation vehicles in an environment of the transportation vehicle,

wherein information about a planned implementation of the driving maneuver is calculated based on the position of the transportation vehicle, wherein the information about the planned implementation of the driving maneuver comprises information about at least one element of the set of first possible planned lane change point, last possible lane change point, and phase of the driving maneuver.

13. The device of claim 12, wherein information about a driving intention on the part of the transportation vehicle is obtained, wherein the calculation is additionally based on the information about the transportation vehicle's own driving intention, wherein the checking step additionally checks whether the cooperative maneuver is compatible with the transportation vehicle's own driving intention, and wherein the provision is additionally based on whether the cooperative maneuver is compatible with the transportation vehicle's own driving intention.

14. The device of claim 12, wherein the driving maneuver is a single lane change to the left, wherein the calculation calculates the cooperative driving maneuver so the cooperative driving maneuver comprises a double lane change of the transportation vehicle to the left, in response to the driving intention on the part of the transportation vehicle comprising a lane change to the left, to facilitate the single lane change to the left of the requesting transportation vehicle.

* * * * *