

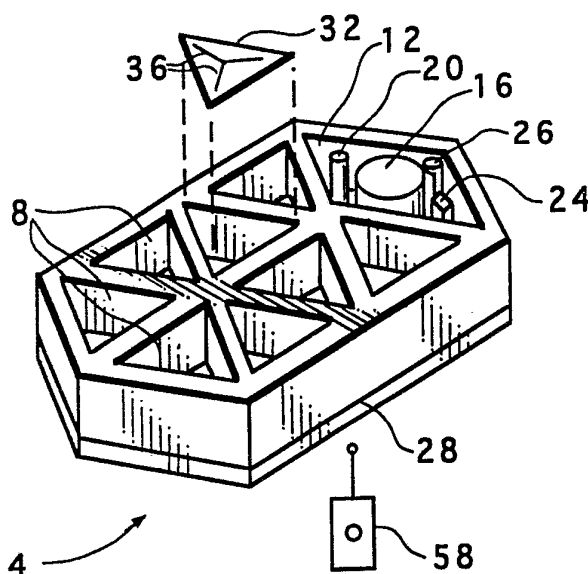

INTERNATIONAL APPLICATION PUBLISHED UNDER THE PATENT COOPERATION TREATY (PCT)

(51) International Patent Classification ⁵ : A61K 9/22	A1	(11) International Publication Number: WO 92/05777 (43) International Publication Date: 16 April 1992 (16.04.92)
<p>(21) International Application Number: PCT/US91/07361</p> <p>(22) International Filing Date: 2 October 1991 (02.10.91)</p> <p>(30) Priority data: 595,087 9 October 1990 (09.10.90) US</p> <p>(71) Applicant: SARCOS GROUP [US/US]; 261 East 300 South, Suite 150, Salt Lake City, UT 84111 (US).</p> <p>(72) Inventors: JACOBSEN, Stephen, C. ; 274 South 1200 East, Salt Lake City, UT 84102 (US). HANOVER, Barry, K. ; 2597 Sherwood Drive, Salt Lake City, UT 84108 (US). SIMON, Eric, M. ; 5619 Emigration Canyon, Salt Lake City, UT 84108 (US). PETELENZ, Thomasz, J. ; 2520 Blaine Avenue, Salt Lake City, UT 84108 (US). MLADEJOVSKY, Michael, G. ; 551 East 4880 South, No. 6L, Murray, UT 84107 (US).</p>	<p>(74) Agents: THORPE, Calvin, E. et al.; Thorpe, North & Western, 9035 South 700 East, Suite 200, Salt Lake City, UT 84070 (US).</p> <p>(81) Designated States: AT (European patent), BE (European patent), CA, CH (European patent), DE (European patent), DK (European patent), ES (European patent), FR (European patent), GB (European patent), GR (European patent), IT (European patent), JP, LU (European patent), NL (European patent), SE (European patent).</p> <p>Published <i>With international search report.</i></p>	

(54) Title: MULTIPLE VESICLE IMPLANTABLE DRUG DELIVERY SYSTEM



(57) Abstract

An implantable drug delivery system includes a housing (4) having a plurality of compartments (8) each of which includes an opening (48) on one side thereof and a floor generally opposite the opening. Also included are a plurality of flexible drug containment sacks (40), each having a mouth (44) circumscribing an opening in the sack, with the sack being disposed in a respective compartment and to enable holding a drug formulation in the sack. A plurality of covers (32) are disposed over a respective compartment opening for preventing the release of drug formulation contained in the sacks in the compartment covered, until ruptured or removed.

FOR THE PURPOSES OF INFORMATION ONLY

Codes used to identify States party to the PCT on the front pages of pamphlets publishing international applications under the PCT.

AT	Austria	ES	Spain	MG	Madagascar
AU	Australia	FI	Finland	ML	Mali
BB	Barbados	FR	France	MN	Mongolia
BE	Belgium	GA	Gabon	MR	Mauritania
BF	Burkina Faso	GB	United Kingdom	MW	Malawi
BG	Bulgaria	GN	Guinea	NL	Netherlands
BJ	Benin	GR	Greece	NO	Norway
BR	Brazil	HU	Hungary	PL	Poland
CA	Canada	IT	Italy	RO	Romania
CF	Central African Republic	JP	Japan	SD	Sudan
CG	Congo	KP	Democratic People's Republic of Korea	SE	Sweden
CH	Switzerland	KR	Republic of Korea	SN	Senegal
CI	Côte d'Ivoire	LI	Liechtenstein	SU ⁺	Soviet Union
CM	Cameroon	LK	Sri Lanka	TD	Chad
CS	Czechoslovakia	LU	Luxembourg	TG	Togo
DE*	Germany	MC	Monaco	US	United States of America
DK	Denmark				

+ Any designation of "SU" has effect in the Russian Federation. It is not yet known whether any such designation has effect in other States of the former Soviet Union.

5

10

MULTIPLE VESICLE IMPLANTABLE DRUG DELIVERY SYSTEM

BACKGROUND OF THE INVENTION

The present invention relates to simple and efficient multiple vesicle drug delivery systems for implantation into an animal or human for delivery of drug to the animal or human incrementally over some period of time.

It is well known in the fields of animal husbandry and veterinary medicine that it is desirable and in some instances necessary to treat or care for farm animals by periodically injecting the animals (or administering orally) with various drugs. If a series of injections or other administrations are required, this may require finding and rounding up the animals, administering the desired drug (or different drugs), and then releasing the animals until the next drug administration is due. Of course, it can be time consuming and costly, each time treatment of a farm animal is required, to locate the farm animal and bring it to a suitable location for treatment. It has been proposed that drug delivery devices be implanted in farm animals for the periodic release of drugs.

Although the devices disclosed in other previous patents serve to deliver a drug or solution to the body of an animal or person in which they are located, the

35

devices are typically limited to specific applications, allow for a one-time discharge (or continuous delivery) of drug into the system of the body in which the device is located, are bulky and therefore difficult to place and maintain in the body, or are complicated and costly to manufacture and use.

SUMMARY OF THE INVENTION

It is an object of the invention to provide a simple and efficient drug delivery system which may be implanted in the body of an animal or human for timed, periodic release of the drug into the body.

It is also an object of the invention to provide such a drug delivery system which is compact and can be readily manufactured.

It is a further object of the invention to provide such a drug delivery system which has a high ratio of drug volume to housing or package volume.

It is an additional object of the invention to provide such a drug delivery system which is reliable and substantially leak free.

The above and other objects of the invention are realized in a specific illustrative embodiment of an implantable drug delivery system which includes a housing having compartments each of which includes an opening on one side thereof and a floor generally opposite the opening, a flexible drug containment sack having a mouth circumscribing an opening in the sack, where the sack is disposed in the compartment with the mouth affixed to the opening of the compartment to seal the inside of the sack from the inside of the compartment and to enable holding a drug formulation in the sack, and a rupturable or removable cover disposed over the compartment opening for preventing release of drug formulation contained in the sack until rupture or removal. Gas generator elements are disposed at the floor of a respective compartment under the compartment sack and are responsive to initiation signals for

producing gas to force the corresponding sacks and drug solutions against the covers, to rupture or remove the covers, and force the formulations out of the compartments. A circuit is also provided in the housing for supplying initiation signals in some predetermined sequence to the gas generating elements to cause the sequential release of drug formulation from the housing.

In accordance with one aspect of the invention each compartment is formed to have a polygonal top cross-section to enable nesting together of the compartments in a compact, side-by-side relationship. A utility compartment is provided in the housing beside the other compartments for containing the signal supplying circuitry.

BRIEF DESCRIPTION OF THE DRAWINGS

The above and other objects, features and advantages of the invention will become apparent from a consideration of the following detailed description presented in connection with the accompanying drawings in which:

FIG. 1 is a perspective view of an implantable drug delivery multiple-vesicle device made in accordance with the principles of the present invention;

FIG. 2 is a side, fragmented, cross-sectional view of the device of FIG. 1;

FIG. 3 is a top, plan, cross-sectional view of another embodiment of a multiple-vesicle drug delivery system made in accordance with the principles of the present invention;

FIG. 4 is a side view of the embodiment of FIG. 3 but showing only a few of the component parts;

FIG. 5 is an isometric, exploded, partially cutaway view of still another embodiment of a drug delivery system made in accordance with the principles of the present invention and utilizing piston or plunger discharge elements in multiple vesicles;

FIG. 6 is a side, cross-sectional view of still another embodiment of a drug delivery system made in accordance with the principles of the present invention and utilizing a plunger in a single cylindrical vesicle;

5 FIG. 7 is a top, plan view of the release mechanism of FIG. 6;

FIG. 8 is a fragmented, side, cross-sectional view of another embodiment of a drug delivery system made in accordance with the principles of the present invention;

10 FIG. 9 is a side, elevational view of one embodiment of a pyrotechnic gas generating element made in accordance with the present invention;

FIG. 10 is a top plan view of the embodiment of FIG. 9;

15 FIG. 11 is a side, elevational view of another embodiment of a pyrotechnic gas generating element made in accordance with the present invention; and

FIG. 12 is a top plan view of the embodiment of FIG. 11.

20

DETAILED DESCRIPTION

Referring to FIGS. 1 and 2 of the drawings, there is shown a low profile, compact drug delivery system made in accordance with the present invention to include a housing 4 having formed therein two (or more) rows of vesicles or compartments 8, each having top, polygonally shaped cross-sections to allow compact nesting together of the compartments. The compartments shown in the FIGS. 1 and 2 embodiment have triangular top cross sections, but other shapes could also be used to achieve the desired nesting.

30

Positioned at one end of the two rows of compartments 8 is a utility compartment 12 in which is housed a battery 16, an oscillator 20, a timing circuit 24, and a receiver and antenna 26. The elements 16, 20, 24 and 26 are mounted on a substrate 28 which forms the floor of the utility compartment 12 and the other compartments 8.

35

Each compartment 8 has an opening at the top which is covered by a rupturable cover, such as the one cover 32 shown. The covers 32 might illustratively be made of a thin metal foil or might be made of a thin plastic sheet. Score lines 36 may be formed in the cover 32 to more readily facilitate the rupture of the cover and the release of the contents of the corresponding compartment (to be discussed momentarily). The housing 4 might advantageously be made of injection molded polycarbonate or other plastics. The substrate 28 might illustratively be made of conventional circuit board material such as a fiberglass and epoxy composite or polyamide film, for carrying the circuit component 16, 20, 24 and 26 and electrical conductors to be discussed later.

Disposed in each compartment 8 is a corresponding drug containment sack 40 having a mouth 44 which circumscribes an opening 48 to the interior of the sack (see FIG. 2). The mouth 44 of each drug containment sack is attached to the opening of the corresponding compartment, at the top thereof, to seal the inside of each sack from the inside of the corresponding compartment. The drug containment sacks are provided for holding drug solution (or powder or granular formulation) to be delivered to an animal into which the drug delivery system is implanted. The sacks 40 might illustratively be made of polyvinylidene chloride, fluorinated ethylene-propylene, or other suitably flexible and fluid and chemical impervious material.

Disposed at the bottom of each compartment on the substrate 28 is a pyrotechnic gas generating element, typically a bead of material 52 which is responsive to heat resulting from an electrical signal applied to a heating element, thereby igniting and producing gas for filling the corresponding compartment. Alternatively, a non-toxic foam may be produced by an ignition material to similarly fill a corresponding compartment. As a

compartment fills with gas, the gas forces the corresponding drug containment sack upwardly and the sack, in turn, forces drug solution against a corresponding cover 32 to rupture the cover and allow
5 the drug solution and sack to be emitted from the compartment. Sack 40b of FIG. 2 is shown fully pushed out of the compartment 8b which ensures that all drug solution initially contained in the sack is released into the animal.

10 The pyrotechnic gas generating material 52 might illustratively be a composition of nitrocellulose or polyvinyl nitrate. Although not shown, a second pyrotechnic gas generating bead might also be included in each compartment to be activated after the first bead
15 has been activated to thereby better ensure the complete release of drug solution from each compartment.

The timing circuit 24 operates in response to a remotely transmitted signal (transmitted by a transmitter 58) received by the receiver and antenna 26
20 to selectively and sequentially connect the battery 16 by way of electrical conductors 56 to the pyrotechnic gas generating beads 52. Remotely transmitted signals could be used simply to initiate operation of the timing circuit 24 which would then periodically activate
25 selected gas generating beads 52 on its own, or the transmitted signals could be used to directly activate a bead with each transmitted signal. (Although the conductors 56 are shown as being under the substrate 28 in FIG. 2, this is for illustrative purposes only and it
30 should be understood that the conductors would be formed upon the substrate by conventional photo-lithographic, vacuum deposition, or other conventional conductor forming techniques.) The conductors 56 could
35 illustratively be made of a relatively low resistance conductive ink made, for example, of a resin and carbon and silver particles. An alternative to initiating operation of the timing circuit 24 by radio or other

signal transmission would be simply to internally set the timing circuit to begin operation some predetermined time in the future--e.g., after supplying the drug delivery system to an animal.

5 The oscillator 20 supplies an oscillatory signal to the timing circuit 24 which is adapted to selectively connect the battery 16 to the pyrotechnic gas generating beads 52 in some preferred order (to activate the beads) and with a predetermined delay between activation of the
10 different beads, to thereby discharge boluses of drug solution into the animal over a period of time.

FIGS. 3 and 4 show another embodiment of a drug delivery system having a short, cylindrically-shaped housing 104 having a plurality of compartments 108
15 formed in a circle about a central utility compartment 112. The utility compartment 112 again includes a battery 116, an oscillator 120 and a timing circuit 124, all mounted on a substrate 128 which forms a common floor for the utility compartment 112 and the other
20 compartments 108. (A receiver and antenna could also be provided for this embodiment as well as the other embodiments, for remote operation, as explained for the FIGS. 1 and 2 embodiment.)

Although the compartments 108 could have openings
25 at the top of the housing 104, similar to the embodiment of FIGS. 1 and 2, the compartments are shown as having openings 132 in the circumferential outer wall of the housing. Drug containment sacks 136 are disposed in each compartment for holding a drug solution, and
30 rupturable covers 140 are disposed over the compartment openings as best seen in FIG. 3. Alternatively to placing individual covers 140 over each of the compartment openings, a single strip cover could be disposed at the circumferential outer side of the
35 housing 104 to cover all of the openings, with appropriate scoring of the cover being made to allow release of drug solution only from those compartments

which are activated. A pair of individually activatable pyrotechnic gas generating beads 144 and 148 (FIG. 3) are disposed in each compartment on the wall opposite the compartment opening (or on the substrate floor), for producing gas to discharge the contents of the compartment in response to an electrical ignition signal.

FIG. 5 shows an isometric, exploded, partially cutaway view of a drug delivery system having an elongate, tubular housing 204. Formed in the housing is a central compartment or vesicle 208, and a plurality of other vesicles 212 disposed in a circle about the central vesicle as shown. The vesicles extend along a substantial length of the housing 204 generally in parallel with one another and include openings at the upper end of the housing. A rupturable cover 216 is disposed over the upper end of the housing to cover the openings of the vesicles, but to also rupture and allow discharge of the contents of a vesicle when a certain fluid pressure is supplied to the cover from inside the vesicle. Although the vesicles 212 are shown to be generally the same size, different size vesicles could be provided to allow for delivery of different amounts of drug--both of this embodiment and the others.

The housing 204 also includes a bottom compartment 220 in which are disposed a battery 224, an oscillator 228 and a timing circuit 232. The compartment 220 is separated from the vesicles 208 and 212 by a floor or substrate 236 in which are located a plurality of pyrotechnic gas generating beads 240. The circuit components 224, 228 and 232 selectively and successively ignite the pyrotechnic gas generating beads 240 in the same manner as discussed for the embodiments of FIGS. 1 and 2 and FIGS. 3 and 4.

Disposed in each vesicle 208 and 212 near the bottoms thereof are pistons or plungers 244. The side surfaces of the plungers 244 are shaped to conform to

and snugly fit within the side walls of the corresponding vesicles so that as a plunger is forced upwardly in a vesicle by gas pressure, it pushes out of the housing a drug formulation contained in the vesicle.

5 The plungers 244 are forced upwardly in the corresponding vesicles by the activation of the pyrotechnic gas generating beads (or other geometric shapes) 240.

Advantageously, the plungers 244 are made of
10 polyurethane, synthetic rubber or paraffin which will allow for a slidably tight fit within the vesicles and will also provide some lubrication to facilitate the sliding of the plungers. The housing 204 could illustratively be made of injection molded
15 polycarbonate.

FIGS. 6 and 7 show respectively a side, cross-sectional view of another embodiment of an implantable drug delivery system, and a top plan view of the release mechanism of the system. The FIGS. 6 and 7 system
20 include a housing 304 having a base end 308 and a discharge end 312. A passive one-way valve 316 is disposed in the discharge end of the housing to allow release of drug formulation contained in the housing when a certain fluid pressure is applied from inside the
25 housing to the valve.

Disposed in the housing is a piston or plunger 320 having a spring receiving hollow 324 on the underneath side thereof. The exterior side wall of the plunger 320 includes axially spaced apart wipers or seals 328 and
30 332 for making intimate but slidable contact with the interior side wall of the housing 304. The plunger 320 is positioned in the housing 304 initially at a location to define a cavity or reservoir 336 above the plunger for holding a drug formulation.

35 Also disposed in the housing 304 is a coil spring 340 which extends from a bottom wall at the base end of the housing 308 upwardly into the hollow 324 of the

plunger 320. A battery 344, oscillator 348 and timing circuit 352 are disposed within the coil spring 340 on the bottom wall of the housing (but could also be disposed in the plunger 320). Disposed above the
5 circuit elements 344, 348 and 352 is a release circuit card 356 (a bottom view being shown in FIG. 7 with the oscillator 348 and timing circuit 352 mounted thereon).

A plurality of different length tethers or fibers 360 are attached at one end to the underside of the
10 plunger 320 and at the other end to release nodes 364 disposed on the circuit card 356. The tethers 360 serve to hold the plunger in place and prevent it from being moved upwardly toward the discharge end of the housing by the spring 340 until selected tethers are released
15 from the circuit cards. In particular, each of the tethers, being a different length, serve to hold or retain the plunger 320 at different distances away from the circuit card 356 until the tether holding the plunger at a respective length is released from its
20 corresponding release node 364. In this manner, the tethers 360 can be successively released to allow a stepwise movement upwardly of the plunger 320 to successively discharge boluses of drug formulation contained in the reservoir 336.

25 The release nodes 364 are composed of a material (e.g., ultra-high-modulus polyethylene) capable of holding the ends of the respective tethers 360 until the material is activated or ignited in response to an electrical signal to either sever or release the
30 corresponding tether end. Each release node 364 is coupled to the timing circuit 352 which selectively supplies an electrical release signal from the battery 344 to the nodes. Release signals are supplied to the release nodes 364 in the order of increasing tether
35 length so that the shortest tether is first released to allow the plunger 320 to move upwardly one increment, the next shortest tether is then released, etc. until

the plunger has been forced by the spring 340 to the top of the housing 304 at the discharge end.

In the event that any tether 360 is not released, then any subsequent release node 364 activated by the timing circuit 352 will not be able to allow any further movement of the plunger 320. Nevertheless, a completion release node 366, located at the point of connection of the tethers 360 to the plunger 320, may be activated to sever or release all tethers to allow a final thrust of the plunger 320 toward the discharge end 312 of the housing. In this manner, even though one of the tethers 360 may have failed to release, activation of the release node 366 would provide for the release of all the tethers and a final movement of the plunger 320.

FIG. 8 shows a fragmented, side, cross-sectional view of another embodiment of a drug delivery system which also utilizes a plunger 404 slidably disposed in a housing 408. A coil spring, not shown but similar to the spring 340 of the system of FIG. 6, is also disposed in the housing 408 to bias or urge the plunger 404 upwardly toward a discharge end of the housing.

The plunger 404 is prevented from its upward movement by a single tether 412 coupled at one end to the plunger 404 and at the other end to a circuit card 416. Successive pairs of points along the length of the tether 412 are joined together by release elements 420 to thus form a series of loops 424 in the tether. The release elements join the two corresponding points of the tether 412 together until activated by release signals supplied by way of conductors 428 by a circuit pack 432. As a release element 420 is activated, the two adjacent points of the tether 412 joined together are released so that the effective length of the tether increases to allow an upward movement of the plunger 404. As a next release element is activated, another loop of the tether is released so that the tether again increases its effective length to allow another upward

movement of the plunger 404. In this manner, by successive application of release signals to the release elements 420, the plunger 404 is allowed successive upward movements to thereby force drug solution located above the plunger to discharge out the discharge end of the housing 408.

FIGS. 9 and 10 show a side, elevational, partially cross-sectional view and a top plan view respectively of a pyrotechnic gas generating element suitable for use in the embodiments of FIGS. 1 through 5 of the drawings. The element is disposed on a substrate or base 504 to include a pyrotechnic material 508 which ignites easily and burns in response to an electrical signal supplied over lead 512 to an igniter strip 516. Such pyrotechnic material might advantageously be composed of nitrocellulose, barium styphnate or tetrazene. The igniter strip 516 might illustratively be made of nickel chromium. Lead 512 might illustratively be copper, copper alloy or gold. The burning of the pyrotechnic material produces gas as required for forcing drug formulation from vesicles of drug delivery apparatus.

To actuate the gas generating element of FIGS. 9 and 10, an electrical signal is supplied to the conductor 512 to flow through the igniter strip 516 causing it to heat and combust the pyrotechnic material 508.

FIGS. 11 and 12 show a side, elevational view and top plan view of another pyrotechnic gas generating element which may be used in the drug delivery apparatus of FIGS. 1-5. The element is disposed on a substrate 604 which includes an electrical conductor 608 formed of aluminum. Disposed on the aluminum strip 608 is a strip of a composition 612 of palladium (about 95 percent) and ruthenium (about 5 percent) which is narrowed or pinched at 616. Disposed over and about the composition 612 is a mass of pyrotechnic material 620 as discussed earlier.

When an electrical signal is supplied to the conductor 608 and to the composition 612, the composition alloys--heats exothermally--and this reaction progresses under the pyrotechnic material to
5 ignite it and thus produce the desired gas. The narrowed portion 616 presents greater resistance to the electrical signal to start the alloying process.

In the manner described, simple, compact drug delivery units may be provided for implantation into an
10 animal to release successive, timed bursts of drug solution. The volume of each unit utilized for drug containment is high relative to the volumes used for containing circuitry or other elements of the units.

It is to be understood that the above-described
15 arrangements are only illustrative of the application of the principles of the present invention. Numerous modifications and alternative arrangements may be devised by those skilled in the art without departing from the spirit and scope of the present invention and
20 the appended claims are intended to cover such modifications and arrangements.

CLAIMS

What is claimed:

1. An implantable drug delivery system comprising
a housing having at least one compartment which
5 includes an opening on one side thereof and a floor
generally opposite the opening,
at least one flexible drug containment sack having
a mouth circumscribing an opening in the sack, said sack
being disposed in the compartment with the mouth affixed
10 to the opening of the compartment to seal the inside of
the sack from the inside of the compartment, and to
enable holding a drug formulation in the sack,
a cover means disposed over the compartment opening
for preventing release of drug formulation contained in
15 the sack,
gas generating means disposed at the floor of the
compartment under the sack and responsive to an
initiation signal for producing gas to force the sack
and drug formulation against the cover means, to open
20 the cover means, and move out of the compartment, and
means for supplying an initiation signal to the gas
generating means.
2. A system as in Claim 1 wherein said cover means
25 comprises a rupturable cover.
3. A system as in Claim 1 wherein said housing has
a plurality of compartments, each having a polygonal top

cross-section, said compartments nesting together in the housing in a compact side-by-side relationship, said system further including a plurality of flexible drug containment sacks, each disposed in a different compartment, a plurality of rupturable cover means, each disposed over a different one of the compartments, and a plurality of gas generating means, each disposed at the floor of a different one of the compartments, wherein said housing has an additional utility compartment positioned beside the plurality of compartments, and wherein said initiation signal supplying means is disposed in the utility compartment to supply initiation signals to each of the gas generating means in a predetermined manner.

15

4. A system as in Claim 3 wherein said housing comprises an integral unitary structure.

5. A system as in Claim 4 wherein said housing further includes a common bottom substrate on which the compartments and initiation signal supplying means are carried.

6. A system as in Claim 5 wherein said plurality of compartments are formed in a circle about the utility compartment.

7. A system as in Claim 6 wherein the openings of the compartments are located on the circumferential outer side thereof, and wherein the gas generating means are each disposed on the circumferential wall of a
5 respective compartment opposite the respective opening.

8. A system as in Claim 6 wherein the openings of the compartments are located at the top of the housing, and wherein the gas generating means are each disposed
10 on the bottom substrate in a respective compartment.

9. A system as in Claim 5 wherein said plurality of compartments are formed in two or more rows, side-by-side, with the utility compartment being disposed at one
15 end of the rows.

10. A system as in Claim 9 wherein the openings of the compartments are located at the top of the housing, and wherein the gas generating means are each disposed
20 on the bottom substrate in a respective compartment.

11. A system as in Claim 2 wherein said covers include scoring at predetermined locations to weaken the covers and allow rupture at such locations when drug
25 solution is forced against the covers.

12. A system as in Claim 11 wherein said covers are comprised of thin metal foil.

13. A system as in Claim 11 wherein said covers are comprised of a polymeric sheet.

14. A system as in Claim 1 wherein said housing is
5 constructed of injection molded polycarbonate.

15. A system as in Claim 1 wherein said gas generating means comprise pyrotechnic compositions of a gas generating material responsive to heat for further
10 heating and producing gas, heating elements disposed in contact with the compositions for heating in response to an electrical signal, and wherein said initiation signals comprise electrical signals.

16. A system as in Claim 15 wherein said heating
15 elements comprises a nickel chromium alloy.

17. A system as in Claim 15 wherein said heating
elements comprise compositions of palladium and
20 rhenium disposed in contact with aluminum.

18. A system as in Claim 15 wherein said
initiation signal supplying means comprises
a power source, and
25 a switching circuit for operating to selectively temporarily couple the power source to the heating elements in a predetermined sequence.

19. A system as in Claim 18 wherein said signal supplying means comprises conductors for carrying electrical signals from the power source to the heating elements.

5

20. A system as in Claim 18 wherein said initiation signal supplying means further comprises means for receiving an externally transmitted signal and for initiating operation of the switching circuit.

10

21. A system as in Claim 1 further including a second plurality of gas generating means, each disposed at the floor of a different one of the compartments, and wherein said initiation signal supplying means comprises means for supplying initiation signals to each of the first plurality of gas generating means in a predetermined sequence, and for supplying initiation signals to the second plurality of gas generating means generally simultaneously following supply to the first plurality.

15
20

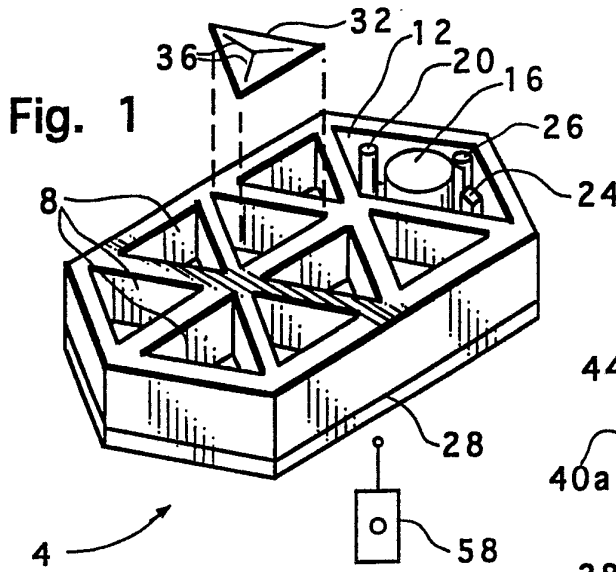

Fig. 1

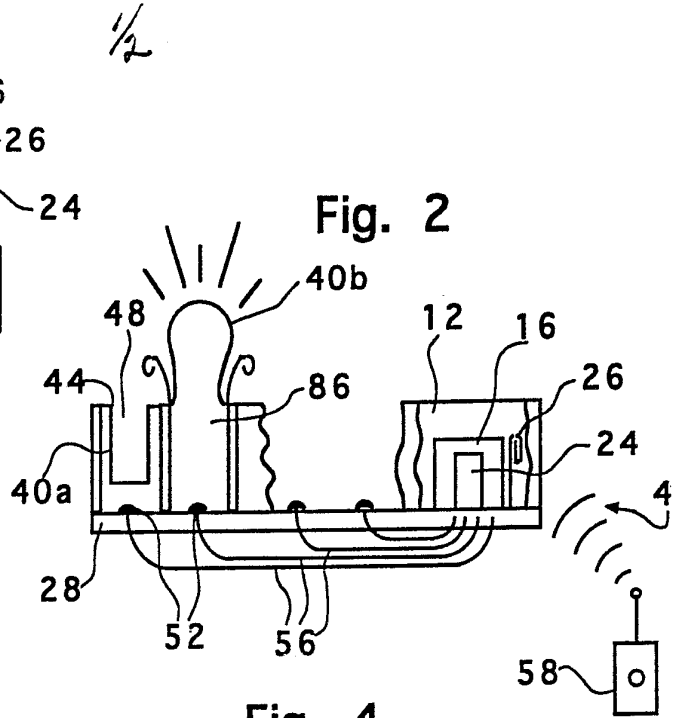

Fig. 2

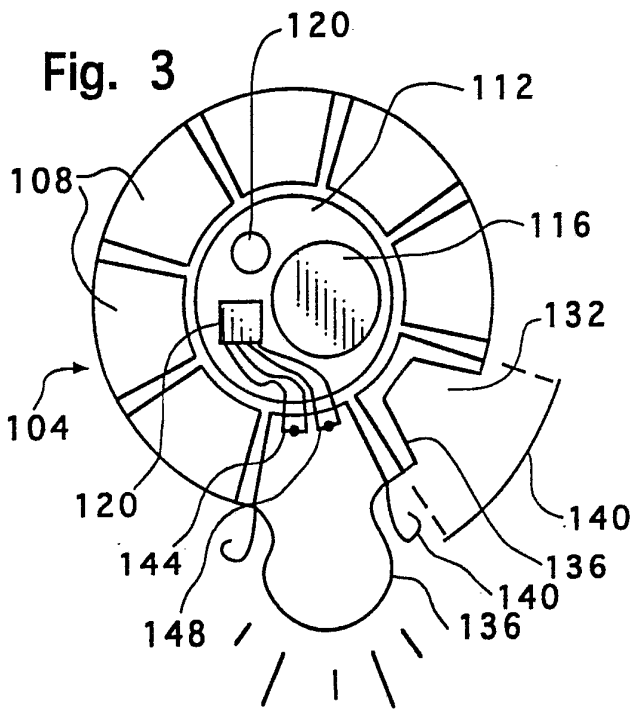

Fig. 3

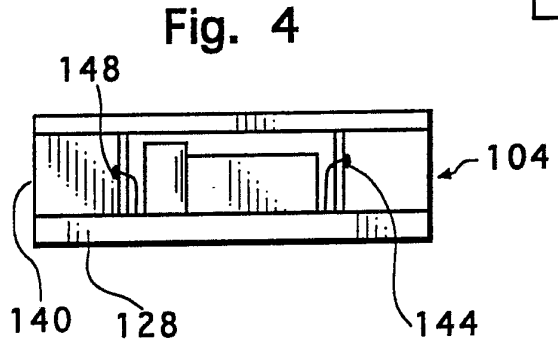

Fig. 4

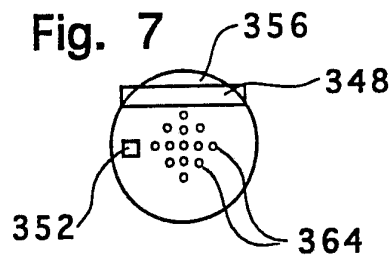

Fig. 7

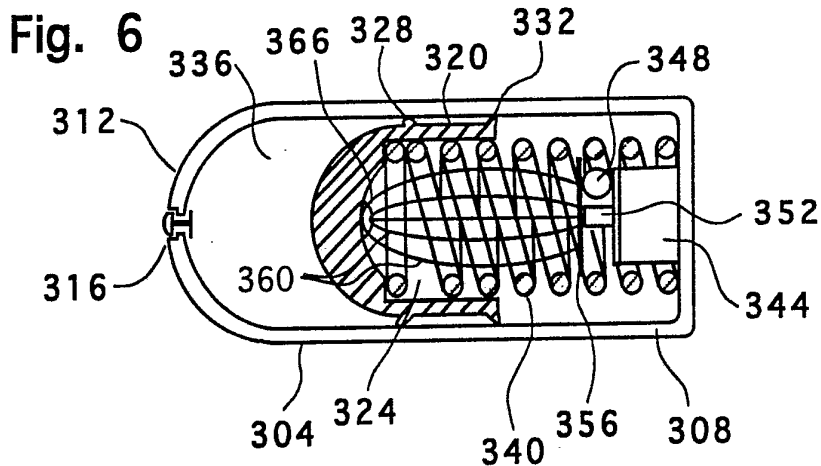

Fig. 6

Fig. 5

2/2

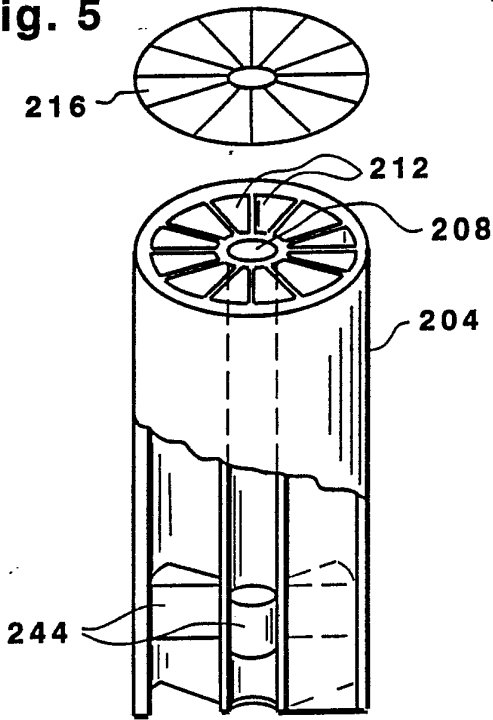

Fig. 8

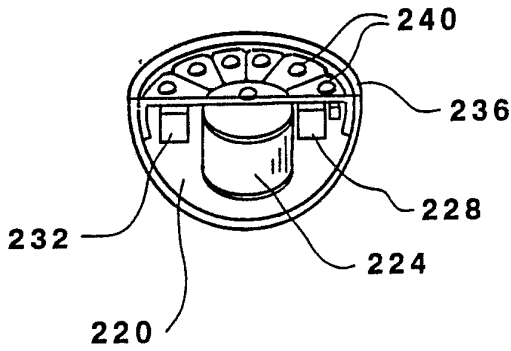
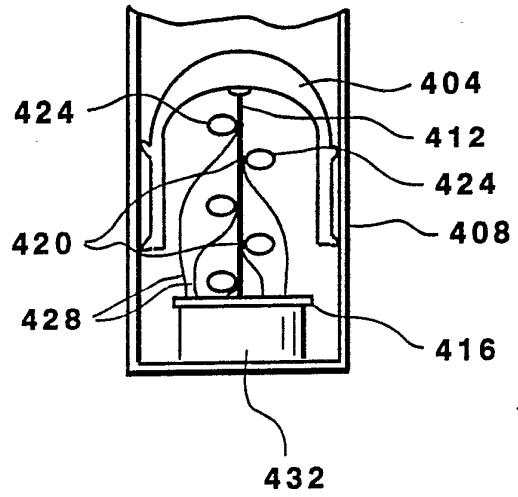

Fig. 10

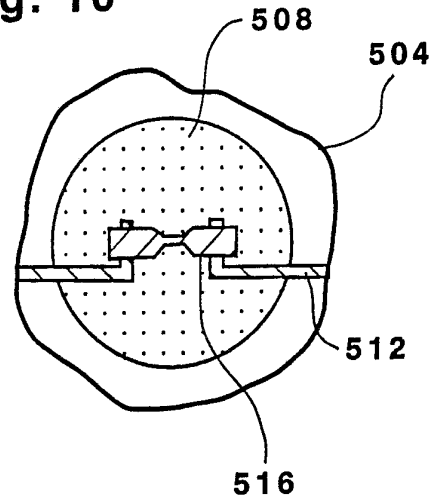

Fig. 9

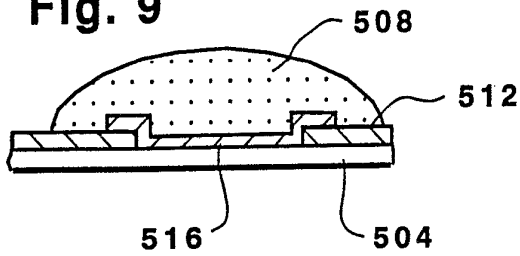

Fig. 12

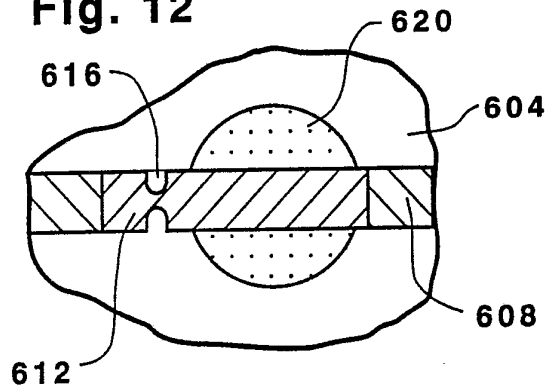
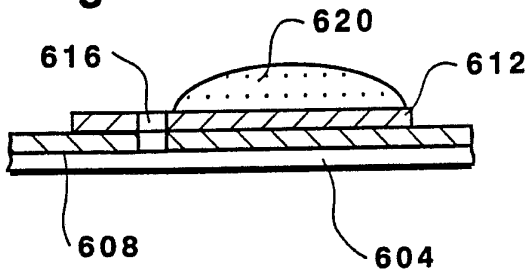

Fig. 11



INTERNATIONAL SEARCH REPORT

PCT/US91/07361

International Application No.

I. CLASSIFICATION OF SUBJECT MATTER (if several classification symbols apply, indicate all) ⁶ According to International Patent Classification (IPC) or to both National Classification and IPC <div style="display: flex; justify-content: space-between;"> US : 604/891.1 IPC(5) ; A61K 9/22 </div>													
II. FIELDS SEARCHED <div style="text-align: center; font-size: small;">Minimum Documentation Searched ⁷</div> <table border="1" style="width: 100%; border-collapse: collapse;"> <tr> <th style="width: 20%; padding: 5px;">Classification System</th> <th style="padding: 5px;">Classification Symbols</th> </tr> <tr> <td style="text-align: center; padding: 5px;">U.S.</td> <td style="padding: 5px;">604/890.1, 891.1, 19, 20, 22, 23, 65, 67, 244, 246, 131, 133, 140, 145, 148, 89, 90 ; 623/24, 25</td> </tr> </table> <div style="text-align: center; font-size: x-small; margin-top: 5px;">Documentation Searched other than Minimum Documentation to the Extent that such Documents are Included in the Fields Searched ⁸</div>		Classification System	Classification Symbols	U.S.	604/890.1, 891.1, 19, 20, 22, 23, 65, 67, 244, 246, 131, 133, 140, 145, 148, 89, 90 ; 623/24, 25								
Classification System	Classification Symbols												
U.S.	604/890.1, 891.1, 19, 20, 22, 23, 65, 67, 244, 246, 131, 133, 140, 145, 148, 89, 90 ; 623/24, 25												
III. DOCUMENTS CONSIDERED TO BE RELEVANT ⁹ <table border="1" style="width: 100%; border-collapse: collapse;"> <thead> <tr> <th style="width: 10%; padding: 5px;">Category [*]</th> <th style="padding: 5px;">Citation of Document, ¹¹ with indication, where appropriate, of the relevant passages ¹²</th> <th style="width: 15%; padding: 5px;">Relevant to Claim No. ¹³</th> </tr> </thead> <tbody> <tr> <td style="text-align: center; vertical-align: top; padding: 5px;">Y</td> <td style="padding: 5px;">US, A, 4564363 (BAGNALL), 14 January 1986 (see figures 7-11; column 3, lines 23-31; column 6, lines 30-33 and line 11; column 4, lines 44-68; column 5, lines 41-50)</td> <td style="vertical-align: top; padding: 5px;">1-5, 9, 10, 14, 15, 18-20</td> </tr> <tr> <td style="text-align: center; vertical-align: top; padding: 5px;">Y, P</td> <td style="padding: 5px;">US, A, 4969873 (STEINBACH ET AL.), 13 November 1990. (See column 3, lines 8-16; column 1, lines 42-68; column 4, lines 64-68; figure 1, elements 2, 3 and 5)</td> <td style="vertical-align: top; padding: 5px;">1-5, 9, 10, 14, 15, 18-20</td> </tr> <tr> <td style="text-align: center; vertical-align: top; padding: 5px;">Y</td> <td style="padding: 5px;">US, A, 4892037 (BETTS), 09 Jan 1990 (see column 1, line 64; column 2, line 6)</td> <td style="vertical-align: top; padding: 5px;">17</td> </tr> </tbody> </table>		Category [*]	Citation of Document, ¹¹ with indication, where appropriate, of the relevant passages ¹²	Relevant to Claim No. ¹³	Y	US, A, 4564363 (BAGNALL), 14 January 1986 (see figures 7-11; column 3, lines 23-31; column 6, lines 30-33 and line 11; column 4, lines 44-68; column 5, lines 41-50)	1-5, 9, 10, 14, 15, 18-20	Y, P	US, A, 4969873 (STEINBACH ET AL.), 13 November 1990. (See column 3, lines 8-16; column 1, lines 42-68; column 4, lines 64-68; figure 1, elements 2, 3 and 5)	1-5, 9, 10, 14, 15, 18-20	Y	US, A, 4892037 (BETTS), 09 Jan 1990 (see column 1, line 64; column 2, line 6)	17
Category [*]	Citation of Document, ¹¹ with indication, where appropriate, of the relevant passages ¹²	Relevant to Claim No. ¹³											
Y	US, A, 4564363 (BAGNALL), 14 January 1986 (see figures 7-11; column 3, lines 23-31; column 6, lines 30-33 and line 11; column 4, lines 44-68; column 5, lines 41-50)	1-5, 9, 10, 14, 15, 18-20											
Y, P	US, A, 4969873 (STEINBACH ET AL.), 13 November 1990. (See column 3, lines 8-16; column 1, lines 42-68; column 4, lines 64-68; figure 1, elements 2, 3 and 5)	1-5, 9, 10, 14, 15, 18-20											
Y	US, A, 4892037 (BETTS), 09 Jan 1990 (see column 1, line 64; column 2, line 6)	17											
<div style="font-size: x-small;"> <p>[*] Special categories of cited documents: ¹⁰</p> <p>"A" document defining the general state of the art which is not considered to be of particular relevance</p> <p>"E" earlier document but published on or after the international filing date</p> <p>"L" document which may throw doubts on priority claim(s) or which is cited to establish the publication date of another citation or other special reason (as specified)</p> <p>"O" document referring to an oral disclosure, use, exhibition or other means</p> <p>"P" document published prior to the international filing date but later than the priority date claimed</p> </div> <div style="font-size: x-small; margin-top: 5px;"> <p>"T" later document published after the international filing date or priority date and not in conflict with the application but cited to understand the principle or theory underlying the invention</p> <p>"X" document of particular relevance; the claimed invention cannot be considered novel or cannot be considered to involve an inventive step</p> <p>"Y" document of particular relevance; the claimed invention cannot be considered to involve an inventive step when the document is combined with one or more other such documents, such combination being obvious to a person skilled in the art.</p> <p>"&" document member of the same patent family</p> </div>													
IV. CERTIFICATION <table border="1" style="width: 100%; border-collapse: collapse;"> <tr> <td style="width: 50%; padding: 5px;"> Date of the Actual Completion of the International Search <div style="text-align: center; font-size: large;">14 December 1991</div> </td> <td style="width: 50%; padding: 5px;"> Date of Mailing of this International Search Report <div style="text-align: center; font-size: x-large; font-weight: bold;">16 JAN 1992</div> </td> </tr> <tr> <td style="padding: 5px;"> International Searching Authority <div style="text-align: center; font-size: large;">ISA/US</div> </td> <td style="padding: 5px;"> Signature of Authorized Officer <div style="text-align: center;"> Chalyn Smith </div> </td> </tr> </table>		Date of the Actual Completion of the International Search <div style="text-align: center; font-size: large;">14 December 1991</div>	Date of Mailing of this International Search Report <div style="text-align: center; font-size: x-large; font-weight: bold;">16 JAN 1992</div>	International Searching Authority <div style="text-align: center; font-size: large;">ISA/US</div>	Signature of Authorized Officer <div style="text-align: center;"> Chalyn Smith </div>								
Date of the Actual Completion of the International Search <div style="text-align: center; font-size: large;">14 December 1991</div>	Date of Mailing of this International Search Report <div style="text-align: center; font-size: x-large; font-weight: bold;">16 JAN 1992</div>												
International Searching Authority <div style="text-align: center; font-size: large;">ISA/US</div>	Signature of Authorized Officer <div style="text-align: center;"> Chalyn Smith </div>												

III. DOCUMENTS CONSIDERED TO BE RELEVANT (CONTINUED FROM THE SECOND SHEET)		
Category *	Citation of Document, with indication, where appropriate, of the relevant passages	Relevant to Claim No
Y	US, A, 4530664 (PRASAD ET AL), 23 July 1985. (See column 1, lines 57-60)	16
Y	US, A, 4299220 (DORMAN), 10 November 1987 (See figure 1, elements 25,31 and 36)	1-5,9,10,14, 15 and 18-20
Y	US, A, 4652261 (MECH ET AL.),24 March 1987 (See figure 2-4).	
Y	US, A, 3923060 (ELLINWOOD, Jr.), 02 December 1975 (See figures 1,2,11 and 12)	
Y	US, A, 4457752 (VADASZ), 03 July 1984. (See figures 2 and 3)	
Y	US, A, 4911692 (MARTIN), (see figure 1)	