



(72) BOGEN, STEVEN A., US  
(72) LOEFFLER, HERBERT H., US  
(71) CYTOLOGIX CORPORATION, US

(51) Int.Cl.<sup>6</sup> G01N 1/31

(30) 1998/02/27 (09/032,680) US

(54) **APPAREIL DE COLORATION DE LAMES DE MICROSCOPE A  
ACCES ALEATOIRE AVEC SEPARATION DE DECHETS  
LIQUIDES**

(54) **RANDOM ACCESS SLIDE STAINER WITH LIQUID WASTE  
SEGREGATION**

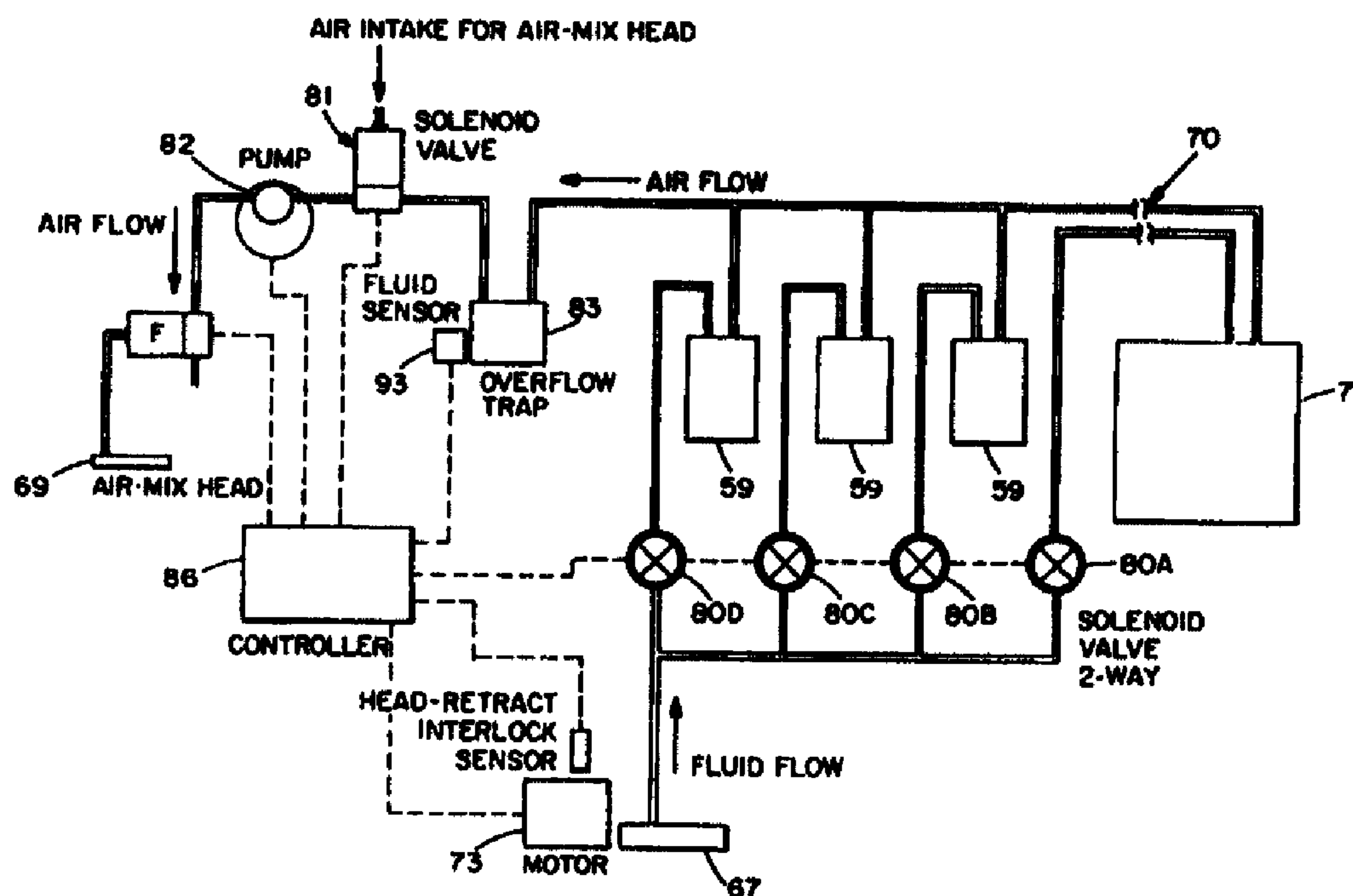

(57) L'invention concerne un appareil de coloration de lames automatique, les lames étant montées sur un carrousel rotatif, dans une position horizontale. Les réactifs et liquides de rinçage sont distribués automatiquement sur des sections tissulaires ou des cellules montées sur des lames, afin de réaliser des colorations chimiques ou immunohistochimiques. Les liquides de rinçage sont éliminés à l'aide d'une tête d'aspiration (31), reliée à une source de vide. La tête d'aspiration (31) est une chambre creuse (40), à fond plat. Huit trous (41) percés dans le fond de la tête d'aspiration permettent d'établir une communication

(57) An automated slide stainer with slides mounted in a horizontal position on a rotary carousel. Reagents and rinse liquids are automatically dispensed onto tissue sections or cells mounted on slides for the purpose of performing chemical or immunohistochemical stains. The rinse liquids are removed by an aspiration head (31) connected to a source of vacuum. The aspiration head (31) is a hollow chamber (40) with a flattened bottom aspect. Eight holes (41) in the bottom of the aspiration head provide for fluid communication between the exterior and interior of the aspiration head. To aspirate liquid off of a slide, the aspiration head is lowered so that



(21) (A1) **2,321,739**  
(86) 1999/02/25  
(87) 1999/09/02

fluidique entre l'extérieur et l'intérieur de la tête d'aspiration. Pour aspirer un liquide de la plaque, on abaisse la tête d'aspiration de sorte que le fond vient en contact avec ledit liquide. Ce liquide est aspiré dans l'intérieur creux (40) de la tête d'aspiration et collecté dans un flacon de collecte de déchets liquides. Plusieurs flacons de collecte de déchets liquides différents (59) sont placés en parallèle, entre la source de vide et la tête d'aspiration. Une électrovanne (80) est placée en ligne avec chaque flacon de collecte de déchets liquides. En fonction de l'électrovanne ouverte, l'opérateur peut orienter le liquide à collecter dans un flacon sélectionné de collecte de déchets liquides.

the bottom aspect contacts the liquid. The liquid is sucked into the hollow interior (40) of the aspiration head and collected into a liquid waste collection bottle. Several different liquid waste collection bottles (59) are placed in parallel, between the source of vacuum and the aspiration head. A solenoid valve (80) is positioned in line with each liquid waste collection bottle. Depending upon which solenoid valve is opened, the operator can direct the liquid waste to be collected into a specified liquid waste collection bottle.

PCT

WORLD INTELLECTUAL PROPERTY ORGANIZATION  
International Bureau

## INTERNATIONAL APPLICATION PUBLISHED UNDER THE PATENT COOPERATION TREATY (PCT)

<p>(51) International Patent Classification <sup>6</sup> : <b>G01N 1/31</b></p>	<p><b>A1</b></p>	<p>(11) International Publication Number: <b>WO 99/44031</b></p> <p>(43) International Publication Date: 2 September 1999 (02.09.99)</p>
<p>(21) International Application Number: PCT/US99/04093</p> <p>(22) International Filing Date: 25 February 1999 (25.02.99)</p> <p>(30) Priority Data: 09/032,680 27 February 1998 (27.02.98) US</p> <p>(63) Related by Continuation (CON) or Continuation-in-Part (CIP) to Earlier Application US 09/032,680 (CON) Filed on 27 February 1998 (27.02.98)</p> <p>(71) Applicant (for all designated States except US): CYTOLOGIX CORPORATION [US/US]; 99 Erie Street, Cambridge, MA 02139 (US).</p> <p>(72) Inventors; and (75) Inventors/Applicants (for US only): BOGEN, Steven, A. [US/US]; 35 Cheryl Drive, Sharon, MA 02067 (US). LOEFFLER, Herbert, H. [US/US]; 53 Spy Pond Drive, Arlington, MA 02474 (US).</p> <p>(74) Agents: SMITH, James, M. et al.; Hamilton, Brook, Smith &amp; Reynolds, P.C., Two Militia Drive, Lexington, MA 02421 (US).</p>		<p>(81) Designated States: AL, AM, AT, AU, AZ, BA, BB, BG, BR, BY, CA, CH, CN, CU, CZ, DE, DK, EE, ES, FI, GB, GD, GE, GH, GM, HR, HU, ID, IL, IN, IS, JP, KE, KG, KP, KR, KZ, LC, LK, LR, LS, LT, LU, LV, MD, MG, MK, MN, MW, MX, NO, NZ, PL, PT, RO, RU, SD, SE, SG, SI, SK, SL, TJ, TM, TR, TT, UA, UG, US, UZ, VN, YU, ZW, ARIPO patent (GH, GM, KE, LS, MW, SD, SL, SZ, UG, ZW), Eurasian patent (AM, AZ, BY, KG, KZ, MD, RU, TJ, TM), European patent (AT, BE, CH, CY, DE, DK, ES, FI, FR, GB, GR, IE, IT, LU, MC, NL, PT, SE), OAPI patent (BF, BJ, CF, CG, CI, CM, GA, GN, GW, ML, MR, NE, SN, TD, TG).</p> <p><b>Published</b> <i>With international search report. Before the expiration of the time limit for amending the claims and to be republished in the event of the receipt of amendments.</i></p>

## (54) Title: RANDOM ACCESS SLIDE STAINER WITH LIQUID WASTE SEGREGATION

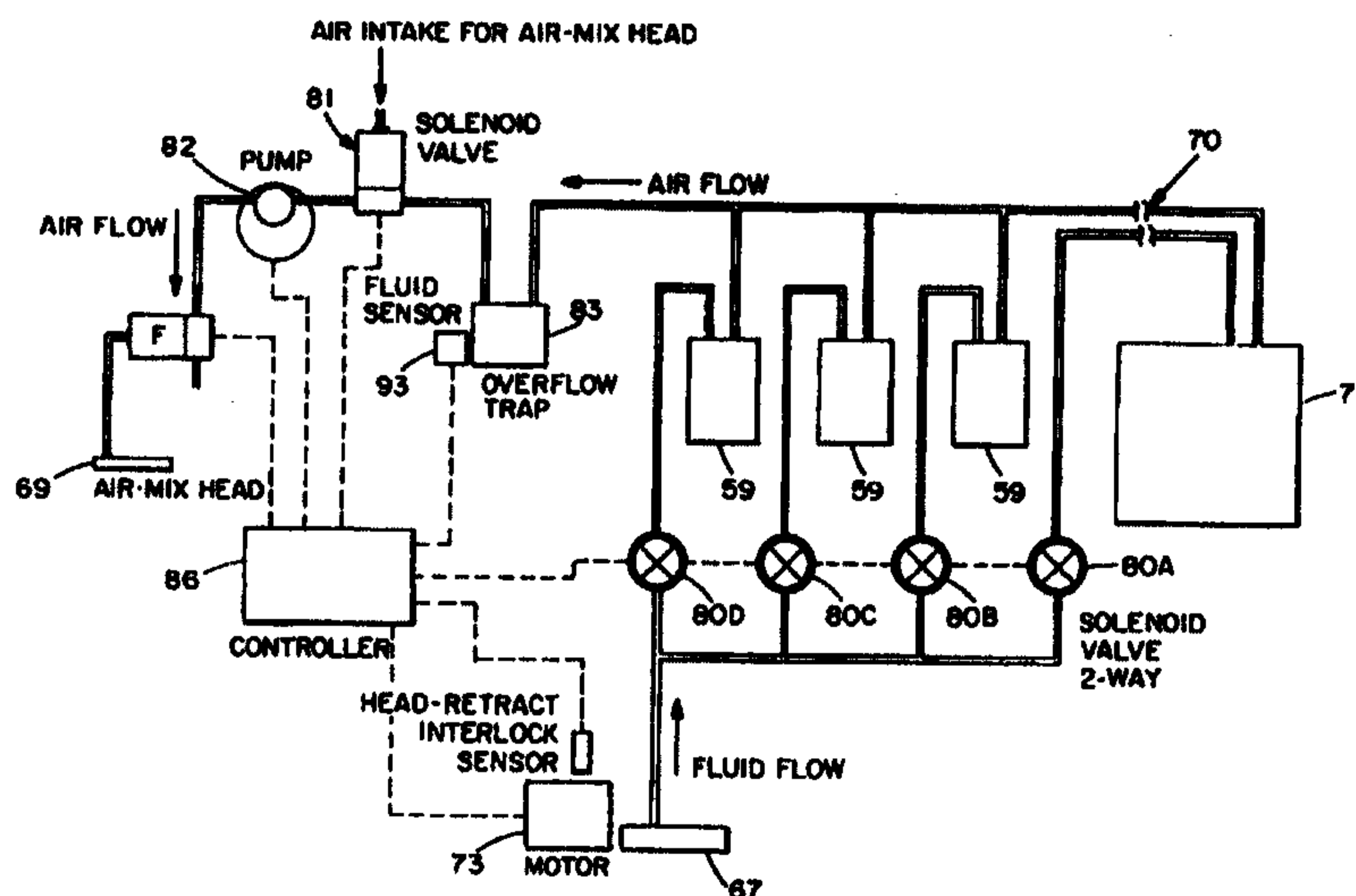

## (57) Abstract

An automated slide stainer with slides mounted in a horizontal position on a rotary carousel. Reagents and rinse liquids are automatically dispensed onto tissue sections or cells mounted on slides for the purpose of performing chemical or immunohistochemical stains. The rinse liquids are removed by an aspiration head (31) connected to a source of vacuum. The aspiration head (31) is a hollow chamber (40) with a flattened bottom aspect. Eight holes (41) in the bottom of the aspiration head provide for fluid communication between the exterior and interior of the aspiration head. To aspirate liquid off of a slide, the aspiration head is lowered so that the bottom aspect contacts the liquid. The liquid is sucked into the hollow interior (40) of the aspiration head and collected into a liquid waste collection bottle. Several different liquid waste collection bottles (59) are placed in parallel, between the source of vacuum and the aspiration head. A solenoid valve (80) is positioned in line with each liquid waste collection bottle. Depending upon which solenoid valve is opened, the operator can direct the liquid waste to be collected into a specified liquid waste collection bottle.

-1-

**RANDOM ACCESS SLIDE STAINER WITH LIQUID WASTE SEGREGATION****BACKGROUND OF THE INVENTION**

Tissue sections are commonly examined by microscopic examination, for both research and clinical diagnostic purposes. Thin tissue sections or cellular  
5 preparations are commonly 1 - 10 microns thick, and are nearly transparent if untreated. In order to visualize various histologic features, a wide array of staining procedures have been developed over the years that highlight various cellular or extracellular components of the tissues.

Histochemical stains, also commonly termed "special stains," employ chemical  
10 reactions to color various chemical moieties. Immunohistochemical stains employ antibodies as probes to color specific proteins, commonly via enzymatic deposition of a colored precipitate. Each of these histochemical and immunohistochemical stains requires the addition and removal of reagents in a defined sequence for specific time periods. Therefore, a need arises for a slide stainer that can perform a  
15 diversity of stains simultaneously under computer control, as specified by the technologist.

Some of these histochemical and immunohistochemical stains employ reagents that may be toxic, carcinogenic, or immiscible in water. Because of increasingly stringent local waste disposal requirements, many laboratories must  
20 now pay to dispose of these wastes through special, hazardous, waste disposal companies. It is therefore desirable to minimize the volume of waste liquid that has to be treated as hazardous waste. With the advent of modern, sophisticated, slide staining automation, it is therefore desirable to incorporate features into an instrument to accomplish that task.

25 A common method for removing waste liquids from the surface of a slide is to flush or blow it off the surface of a slide into a common catch basin. A representative example of such an approach is that described in U.S. Patent #5,595,707. In that embodiment, reagent is removed from the slide by either

blowing with a gas stream or flushing with a liquid reagent. Liquid falls off the slide into a catch basin. A similar approach (using a common catch basin for all liquid waste) is taken in several other slide stainers, described in U.S. Patents 5,425,918 and 5,231,029, and that of Stark, E., et. al. 1988, An automated device for immunocytochemistry, *J. Immunol. Methods* 107:89-92.

A similar design approach is evidenced by the slide stainer marketed by BioGenex Corporation, described in U.S. Patent 5,439,649. It uses a similar catch basin for collecting liquid waste. This design approach causes the entire catch basin to become contaminated. The disadvantage of this approach is that the contaminated or toxic liquid is spread over a larger surface area than the slide itself, as it is caught in a basin. In order to ensure that the next waste liquid will not contain residual amounts of the toxic material, the catch basin must be flushed with a larger volume of wash solution. This results in an increased volume of toxic liquid waste for special hazardous disposal.

An alternative design approach to handling waste liquids from a slide stainer is described in U.S. Patent 4,543,236. Their invention shows a means for aspirating liquid waste, under force of vacuum, to a common waste bottle. In that invention, liquid waste is aspirated through drain lines permanently connected to each slide-containing vessel. A dedicated valve for each slide-containing vessel opens to allow aspiration of the liquid contents. The system is "closed," in that the liquid supply and waste lines do not become exposed to the atmosphere. An advantage of this approach is that liquid waste is not spread around a large catch basin. However, the drawback of this design is that a dedicated valve and permanent tubing lines are required for each slide-containing vessel. As the number of slides increases, the apparatus becomes expensive and complex to assemble and repair. This limitation was apparent in their particular embodiment, as the staining apparatus only accommodated five slides.

A conceptually similar approach is described in U.S. Patent 4,358,470, except that in this invention, waste liquids are channeled into their original containers, to be used repetitively. Their invention did not require a large number of distinct procedures to be applied to different microscope slides. Rather, all of the

-3-

biological specimens, mounted on electron microscopic grids, were held in a common chamber and treated in an identical manner. With only a single incubation chamber, permanently closed plumbing lines for liquid supply and waste was a reasonable, cost-efficient, design. It would not be applicable to situations where  
5 numerous slides are to be stained using different chemical staining procedures.

A third method of automated slide staining for immunohistochemistry was described by Brigati, U.S. Patent 4,731,335. In that invention, liquid was applied to and removed from capillary gaps that were formed by two slides closely apposed together. To remove the liquid, the edges of the slides were abutted against  
10 absorbent towels, causing the liquid to be adsorbed. Therefore, waste liquid was in a solid, adsorbed form.

A fourth method for rinsing slides has been to simply dip the slides containing a reagent into a vat of liquid, such as water or buffer. The reagent dilutes out in the excess volume of liquid wash solution, preparing the slide for treatment  
15 with the next reagent that is scheduled to be applied. An example of that approach is the slide stainer described in U.S. Patent 4,092,952. A similar (dipping of slides into a vat) approach, specially tailored for immunohistochemistry, is described in a publication by Muir and Alexander, 1987, Easier immunoperoxidase staining with labour saving incubator box. *J Cain Pathol* 40:348-50.

20 A previous invention by one of the present inventors, U.S. Patents 4,847,208 and 5,073,504, disclosed a means for aspirating liquids from the surface of slides. A pipette is manually lowered until it is in contact with the wetted slide surface. Liquid was aspirated into a single waste bottle by vacuum force.

#### SUMMARY OF THE INVENTION

25 This invention relates to an improved slide staining device, for the application and removal of reagents to biologic tissue sections mounted on microscope slides. The improvement relates to a method of segregating liquid wastes after application to biological specimens mounted on microscope slides. With this invention, it is possible to remove liquids from the microscope slide  
30 surface and collect some waste liquids in different containers than other liquids.

Certain waste liquids, such as organic solvents, liquids immiscible with water, or biohazardous chemicals, are not to be flushed down the drain in many cities. Rather, local water resource regulations require that these compounds be segregated from regular aqueous waste, and disposed of through special methods. Moreover, the invention incorporates a novel aspiration head that efficiently removes liquid from the entire surface of the microscope slide. This invention provides a means to collect toxic waste liquids in small volumes for economical disposal.

In accordance with the present invention, a slide stainer comprises a slide support adapted to support at least one microscope slide in a horizontal position to retain liquid on its surface. An aspiration head, in fluid continuity with the source of vacuum, is caused by an actuator to contact the liquid on the slide surface. A liquid director directs liquid waste to collect in a selected one of plural waste collection containers.

Preferably, the aspiration head comprises a hollow manifold having plural apertures through a planar surface which is essentially parallel to the microscopic slide during liquid waste aspiration. The planar surface contacts the liquid on the slide but does not directly touch the biological specimen.

Preferably, plural slides are mounted in a horizontal position on a rotary carousel and a liquid aspiration station is provided in a fixed location on the periphery of a carousel, the carousel being moved to select the slide from which liquid is aspirated.

More specifically, the preferred embodiment comprises a rotary carousel of microscope slides carrying biologic samples, such as tissue sections or cell smears. The slides are indexed to a liquid aspiration station which has an aspiration head for removing the liquid waste from the surface of the microscope slide. Since the liquid is spread out in a planar fashion, upon a flat microscope slide, the aspiration head is designed to have a similarly shaped flat bottom surface. Eight holes are present in the bottom surface of the aspiration head that allow for communication between the hollow aspiration head and the exterior. The hollow interior is in fluid continuity with a source of vacuum. Several liquid waste bottles are positioned in a parallel configuration, between the vacuum source and the aspiration head. Each liquid

-5-

waste bottle inlet is normally closed off with a solenoid valve. When liquid is to be aspirated, a selected bottle's solenoid valve opens. The aspiration head is electromechanically lowered so that its bottom surface contacts the liquid on the microscope slide. In this manner, suction force is transmitted directly to the holes  
5 on the aspiration head, causing the liquid to be collected in the selected liquid waste bottle.

### BRIEF DESCRIPTION OF THE DRAWINGS

The foregoing and other objects, features and advantages of the invention will be apparent from the following more particular description of preferred  
10 embodiments of the invention, as illustrated in the accompanying drawings in which like reference characters refer to the same parts throughout the different views. The drawings are not necessarily to scale, emphasis instead being placed upon illustrating the principles of the invention.

FIG. 1 is a perspective view of a first embodiment of a slide stainer.

15 FIG. 2 is a top view of a slide frame for providing five sealed cavities above five different slides holding tissue samples.

FIG. 3 is a top view of a slide frame base.

FIG. 4 is a bottom view of a slide frame housing.

20 FIG. 5 is a top view of the slide frame housing with five microscope slides in their appropriate positions, showing the area to which heat is applied.

FIG. 6 is a cross-sectional view of a slide frame resting on the slide rotor.

FIG. 7 is a schematic diagram of the heater and sensor wiring diagram, on the slide frame, and the interconnection with the temperature controller.

25 FIG. 8 is a side cross-sectional view of a cartridge pump dispensing mechanism in the liquid dispensing and removal station.

FIG. 9 is a side cross-sectional view of a bulk liquid dispensing station housed in the liquid dispensing and removal station.

30 FIGS. 10A and 10B are side cross sectional views of a vacuum hose and transport mechanism for removing liquid reagent and wash fluids from slides contained on the slide rotor.

-6-

FIG. 11A is a side cross-sectional view of the aspiration head, showing its relationship to the glass slide in the slide frame.

FIG. 11B is a bottom en face view of the aspiration head.

FIG. 12 is a perspective view of a second embodiment of a slide stainer.

5 FIG. 13 is a perspective view of the liquid handling zone of the second embodiment of the slide stainer.

FIGS. 14A and 14B are side cross-sectional views of the liquid aspiration station of the second embodiment, with the aspiration head in the lowered (FIG. 14A) and raised (FIG. 14B) positions.

10 FIG. 15 is a schematic representation of the waste liquid pathways of the second embodiment.

FIG. 16 is a schematic representation of the bulk liquid dispense pathways of the second embodiment.

15 FIG. 17 is a schematic representation of the individual heaters on the slide rotor and the temperature control boards mounted on the slide rotor.

FIGS. 18A-D are a schematic diagram of the electronic circuitry of the temperature control board.

#### DETAILED DESCRIPTION OF THE INVENTION

FIG. 1 shows a first embodiment 1 of the invention in perspective view.

20 Generally, the first embodiment 1 comprises a substantially circular assembly base 2, a slide rotor 3 rotatable on the assembly base 2, a reagent rotor 4 also rotatable on the assembly base, and a liquid dispensing and removal station 5.

The slide rotor 3 is driven to rotate by a servo motor (not shown) and carries ten slide frames 6 that are radially asserted into and detachable from it. A top view of single slide frame 6 is shown in FIG. 2. Here, positions for five slides, each with a tissue sample, are shown in positions 7a - 7e. The slide frame 6 comprises a slide frame base 8 shown in FIG. 3. The slide frame base 8 includes a heated area 9 which underlies each of the slide positions 7a - 7e and incorporates resistive heating elements, not shown. The heating elements are integrally formed in the slide frame base 8. Electricity for powering the heating elements is provided into the slide

25

30

-7-

frame 6 from the assembly base 2 via first and second contacts 10. Further, third and fourth contacts 11 enable temperature sensing of the heated areas via thermocouples also integrally formed in the slide frame base 8. In practice, a sum of three connectors are required, since contacts 10 and 11 share the same ground connection. Therefore, one of the connectors 11 are left unused.

Adapted to overlay the slide frame base is a slide frame housing 12. FIG. 4 is a top view of the slide frame housing 12 showing essentially a rigid plastic or metal frame 13 with five oval holes 14a - 14e corresponding to each of the slide positions 7a - 7e. A silicon rubber gasket 15 is also provided under the frame 13. Returning to FIG. 2, the slide frame housing 12, including the gasket 15 and frame 13, is bolted onto the slide frame base 8 by two Allen bolts 16 to provide individual sealed cavities approximately 0.2 - 0.4 inches deep over each tissue sample slide placed at each of the slide positions 7a - 7e. As a result, a total of 3 ml of reagents and/or rinses can be placed in contact with the tissue samples of each one of the slides but a maximum quantity of 2 ml is preferable. Since the silicon gasket 15 is compressed by the frame 13 against the microscope slides (not shown), the cavities over each of the frame positions are mutually sealed from each other.

FIG. 5 is a top view of a slide frame base 8 with five microscope slides 17 in the positions denoted by 7a - 7e in FIG. 3. The area of each slide 17 forming cavities, that are delimited by the silicone rubber gasket 15 and holes 14a - 14e is indicated by an approximately rectangular line 18, marking the chamber wall. The area denoted by the hatched bars indicates the area of the slide frame base 8 that includes heating elements 9. The entire heated area (hatched bars) is raised to the same temperature, bringing the group of five slides to the same desired temperature. The portion of each slide 17 that is not above the heated area does not generally bear a biologic tissue specimen. Rather, it is used for labeling purposes.

FIG. 6 is a cross-sectional view of an assembled slide frame base 8 and housing 12, collectively referred to previously as the slide frame 6. The microscope slide 17 is shown held in position, between the slide frame base 8 and housing 12. The slide frame 6 is resting on the slide rotor 3. In this view, the electrical connection between the slide frame 6 and an edge connector 19 is demonstrated.

-8-

Four edge connectors per slide frame 6 are provided (contacts 10 and 11 in FIGS. 2 and 3). The electrical connection is fed from the edge connector 19 through the slide rotor via an insulated feed-through 20, to a terminal underneath the slide rotor 3. A wire then connects the terminal to a source of power or control circuitry (not shown).

FIG. 7 is a schematic diagram, showing two out of the ten heater 91 and sensor 92 circuits that can be placed on the instrument slide rotor. The heater is represented schematically as a resistive element, and corresponds to the heated area (hatched bars) of FIG. 5. Contacts 10 and 11 share a common ground connection, leaving one of the four connectors unused. Each of the circuits feeds into a temperature controller, represented schematically 21. Each slide frame sends three wires to the temperature controller 21 - - a heater power conductor 22, a sensor conductor 23, and a ground connection 24. The temperature controller 21 is mounted in a stationary position on the assembly base 2. Since the heaters and sensors are in frequent motion, they connect to the stationary temperature controller 21 via a service loop (not shown). The service loop contains the wires from each of the edge connectors 19. Sufficient extra length is provided in the wires so that as the slide rotor rotates, the service loop travels around the slide rotor axis. The slide rotor 3 does not turn more than one full revolution in either direction. The wires in the service loop are preferably bundled together with a wire tie, so that individual wires do not become entangled or caught underneath the slide rotor 3. Since there are three wires per circuit (wires 22 - 24), and there are ten slide frames 6 on the slide rotor 3, the service loop contains a minimum of thirty wires.

Referring to FIG. 1, positioned above the slide rotor 3 is the reagent rotor 4. This reagent rotor is similarly adapted to rotate on the assembly base 2 and is driven by another servo motor (not shown) under computer control (not shown). The reagent rotor 4 and the slide rotor 3 rotate independently of each other. The reagent rotor 4 is adapted to carry up to ten cartridge frames 25. Each of these cartridge frames 25 are detachable from the reagent rotor 4 and can be selectively attached at any one of ten possible points of connection. Each cartridge frame 25 is capable of carrying five of the cartridge pumps 46.

-9-

Generally, the dispensing station 5 comprises a soft hammer 26 for engaging a portion of the cartridge pumps 46. The cartridge pumps 46 are constructed so as to dispense liquid when a portion of the cartridge pump 46, called the metering chamber 42 of the cartridge pump 46 is compressed. It is possible to dispense from any of a plurality of cartridge pumps by rotating the reagent rotor so as to align a desired cartridge pump 46 with the hammer 26. This provides the capability of dispensing precisely measured amounts of reagent to any slide positioned underneath the cartridge pump 46 adjacent to actuator 26. The mechanism for dispensing from the cartridge pumps 46 is shown in greater detail in FIG. 8. The hammer 26 is driven by a solenoid or linear stepping motor 43 that is mounted on a front wall 44, attached to the assembly base 2. In FIG. 8, the hammer is shown compressing the metering chamber 42 portion of the cartridge pump. It is important to be able to adjust the speed of compression by the hammer 26 upon the metering chamber 42. Otherwise, too rapid a compression will cause an excessively forceful ejection of reagent from metering chamber 42, potentially damaging the tissue section underneath. Therefore, a linear stepping motor is preferred instead of a solenoid. As another alternative, the reciprocating hammer of the dispensing actuator could take the form of a cam, driven by a rotary motor, that engages the metering chamber 42 so that the rotation of the cam will compress the metering chamber.

The cartridge pump 46 is comprised of a liquid reservoir 45 and the metering chamber 42. The liquid reservoir 45 shown in this first embodiment 1 is a syringe barrel. The metering chamber 42 is comprised of a compressible elastomeric housing with a one-way inlet valve (not shown) and a one-way outlet valve (not shown), both valves aligned in a downwards direction of fluid flow. When the hammer 26 compresses the metering chamber 42, the liquid reagent contained within is ejected. When the compressive force is removed, the negative pressure created by the expansion of the elastomeric housing, trying to resume its native, non-compressed shape, causes liquid to flow inwards from the liquid reservoir 45. In this manner, repetitive compression of the metering chamber 42 causes repetitive dispensing of small aliquots of reagent. Alternative cartridge pumps are presented in

-10-

U.S. Patent application Serial Number 08/887,178 filed July 2, 1997 and U.S. Patent application Serial Number 09/020,983 filed February 10, 1998, which are incorporated herein by reference.

5 The dispensing station 5 further includes a means to dispense liquids from a large bottle (FIG. 9). Bulk liquid bottles 27 that can supply liquid into any one of the microscope slides 17 on any one of the slide frames 6 via rinse tubes 28. Each bulk liquid bottle 27 is connected to its own rinse tube 28. The bulk liquid bottles 27 are pressurized by a pump (not shown). The outflow tube (not shown) from each bulk liquid bottle 27 passes through a valve 47 that regulates the flow of liquid from  
10 that bottle. By opening the valve for a defined period of time, under computer control (not shown), with a defined pressure within the bottle 27, a known quantity of liquid can be dispensed onto the slide 17. The liquids placed within the bottles 27 are those that are used repeatedly among many different procedures, such as water, saline, and alcohol.

15 As shown in FIG. 9, the bulk liquid bottles 27 are screwed into a female threaded cap 48 secured to the underside of the horizontal top wall 49 of the station frame. Compressed air from a compressor (not shown) is provided to each bulk liquid bottle 27 through a pressure regulator 50. Tubing from the pressure regulator 51 transmits the compressed air to the inlet of the bulk liquid bottle 27. The  
20 pressure above the liquid enables the liquid to forced up through the dip tube 52 through the rinse hose 53 when a pinch valve 47 is opened. Depending on the length of time that the pinch valve is opened, a pre-determined amount of liquid can be dispensed through the rinse tube 28.

The liquid dispensing and removal assembly 5 further includes a liquid  
25 removal vacuum station, positioned adjacent to the rinse tubes 28 (not visible in FIG. 1). In order to remove liquid from the surface of a slide 17, the reagent rotor positions the slide at the liquid removal vacuum station, shown in a side cross-sectional representation in FIGS. 10A and 10B. An external source of vacuum (not shown) is channeled through a trap flask 29, ultimately leading to a vacuum  
30 hose 30 that terminates in an aspiration head 31. The tubing connections are not shown in FIGS. 10A and 10B. The vacuum hose 30 and aspiration head 31 are

-11-

supported by a hose transport mechanism 54 that allows the aspiration head 31 to be extended down into a cavity of a slide frame 6 to remove liquid covering the tissue sample on the slide 17. As the aspiration head contacts the liquid, the liquid is sucked upwards into the tubing and collected into the trap flask 29.

5           The vacuum hose transport mechanism 54 comprises a motor 32. A reciprocating link 33 is attached to a crank arm 34 so that the rotation of the motor 32 causes the reciprocating link 33 to traverse in a vertical direction. A bottom portion of the reciprocating link 33 is connected to a lever 55 that is pivotally attached to the station frame. The other end of this lever is connected to a vacuum  
10 hose clamp 35 that is connected via pivot arms 36 to a plate 37 rigidly attached to the station frame. The net effect of these connections is that when the motor 32 is rotated, the slide arm 33 descends in a vertical direction. Thus, the lever 55 is pivoted clockwise around its fulcrum causing the hose clamp 35 to pivot up and away on the two pivot arms 36 from the slide as shown in FIG. 10B. The motor is  
15 automatically turned off as the link 33 reaches its two extreme ends of movement by the contact of the electrical terminals 39 of the link to the contact plates 38 connected to the station frame.

          The aspiration head 31 is shown in greater detail in FIGS. 11A and 11B. FIG. 11A shows the aspiration head in a lowered position, in cross-section, within  
20 the cavity formed by the slide frame 6. The aspiration head 31 comprises a hollow interior manifold 40 through which the vacuum force is transmitted across the entire lower surface of the aspiration head 31. Eight holes 41 are drilled on the lower face of the aspiration head 31, through which the suction force is transmitted. Since the microscope slide 17 is planar, liquid on the slide surface spreads out in two  
25 dimensions. Therefore, in order to thoroughly remove liquid from all portions of the microscope slide 17, multiple aspiration sites are needed. We accomplish this with an aspiration head with a planar lower surface with multiple holes. The planar surface of the aspiration head 31 comes into close parallel apposition to the microscope slide 17. The aspiration head only contacts the liquid, not the  
30 microscope slide itself, lest it damage the glass slide 17 or the biologic specimen that it carries (not shown). Without such a design and only a single aspiration site,

PCT/US99/04093

-12-

such as from a pipette, liquid distant from the aspirator would not be removed. Rather, it would cling to the distant surfaces of the glass slide 17, because of the surface tension on the glass. This would result in a residual volume of liquid that would otherwise be left on the surface of the slide 17. Having a close parallel apposition of the aspiration head is also helpful from the perspective of decreasing surface tension during liquid aspiration. The close parallel apposition of the bottom surface of the aspiration head with the microscope slide 17 creates a type of capillary gap. This gap helps to overcome surface tension, ensuring complete liquid removal.

A computer (controller 86 in FIG. 15) controls the instrument functions. That is, an operator programs the computer with the information such as the location of reagents on the reagent rotor and the location of slides on the slide rotor. The operator then programs the particular histochemical protocol to be performed on the tissue samples. Variables in these protocols can include the particular reagent used on the tissue sample, the time that the tissue sample is allowed to react with the reagent, whether the tissue sample is then heated, the rinse that is then used to wash the reagent away, followed by the subsequent removal of the rinse and reagent to allow subsequent exposure to a possibly different reagent. The instrument enables complete random access, i.e., any reagent to any slide in any sequence.

A second, preferred, embodiment of the invention is shown in FIG. 12. Like the previous embodiment, it also comprises two independent carousels that rotate on an assembly base 56. Bulk liquid bottles 57 are mounted on a bridge 58 that extends across the width of the entire machine, above the reagent rotor. A separate group of trap bottles 59, for collecting waste liquid, are mounted on the side of the bridge 58 in a compartmentalized shelf. The tubing connections and valves for the bulk liquid bottles 57 and the trap bottles 59 are hidden from view by an upper panel 60. The front and sides of this embodiment are surrounded by a plexiglass case 61, that can be manually slid sideways in order to insert cartridge pumps 62 or slides (not shown). Slides are individually inserted and removed via a centrally located slide access door 63. The slides (not shown) are hidden from view by a circular platen 64 that is located above the slides and reagent rotor (not shown). Functions similar to the dispensing assembly (5 of FIG. 1) in the previous embodiment are accomplished

-13-

in a somewhat similar liquid handling assembly (not shown) that is positioned in a liquid handling zone 65.

FIG. 13 shows the individual mechanisms contained within the liquid handling zone 65, including a hammer 66 for dispensing from cartridge pumps (not shown), an aspiration head 67 for removing liquid from the surface of slides, a bulk liquid dispensing port 68, and an air-mix head 69 for spreading and mixing liquids on the surface of a slide. The electromechanical mechanism for dispensing from cartridge pumps, by compressing a hammer 66 upon a metering chamber of a cartridge pump (not shown in FIG. 13), is similar to the previous embodiment (FIG. 8). Reagent dispensed from the cartridge pump (not shown) flows onto the slide by passing through a roughly rectangular hole in the platen 64.

The aspiration head 67 also functions in a similar manner to that of the previous embodiment. In order to simplify the linkage mechanism for lowering and raising the head 67, the head moves solely in a vertical direction. This is shown in further detail in FIGS. 14A and 14B. FIG. 14A shows a side cross-sectional view of the aspiration head in a down position, within a cavity formed by the microscope slide 75 (bottom surface) and a slide chamber clip 76 (lateral walls). As in the first embodiment, a gasket (not shown) seals the surface where the slide chamber clip 76 contacts the microscope slide 75. A linear stepper motor 73 moves the aspiration head up and down, under computer control (demonstrated schematically in FIG. 15). As in the first embodiment 1, the aspiration head 67 comprises a hollow manifold 74 connected to a source of vacuum. Eight holes communicate between the bottom of the aspiration head 67 and the exterior, through which liquid is aspirated. When vacuum is supplied to the aspiration head 67, and the head 67 is lowered adjacent to the slide, the liquid reagent on top of the slide is aspirated off and collected in a trap bottle 59 (shown schematically in FIG. 15). When the aspiration head 67 is not in use, it is raised to the up position (FIG. 14B), allowing free rotation of the slide rotor 77.

FIGS. 14A and 14B also show the physical location of a heating element 78, represented as a resistive element inside a rectangular box with cross-hatched lines. Each slide rests directly on the heating element 78, so that heat is directly

-14-

communicated to the microscope slide. A thermistor is incorporated into each heating element (not shown in FIGS. 14A and 14B). Each of forty-nine microscope slides 75 has its own heating element 78, so that the temperature of each slide 75 can be independently regulated. Power for the heating element 78 is supplied directly  
5 from a temperature control board 79 that is affixed to the underside of the slide rotor 77. Seven identical temperature control boards 79 are so mounted underneath the slide rotor 77, evenly spaced around the periphery. Each temperature control board supplies power for seven heating elements 78. The means by which this is accomplished is explained later, in reference to FIGS. 17 and 18.

10 An important aspect of this embodiment is the provision for the segregation of waste liquids that are removed from the surface of the slide. A schematic diagram explaining how this is accomplished is shown in FIG. 15. Three different waste bottles 59 are mounted on the instrument. Connections 70 are also provided on the instrument for a large external trap bottle 71, typically of a ten or twenty liter  
15 capacity for aqueous waste. Four solenoid valves, labelled 80A - 80D control to which bottle aspirated liquid will be directed. These valves are under computer control, schematically represented by the box labelled "controller" 86. Valve 81 is a three way valve. It can allow a direct connection between the vacuum pump 82 and the overflow trap 83, or between the pump and the ambient environment. A  
20 connection to the ambient environment is required if the aspiration system needs to be bypassed when the air-mix head 69 is in use. If valves 80A and 81 are appropriately opened, the pump 82 turned on, and the aspirator head 67 lowered so as to aspirate liquid, the liquid will be directed upwards into the tubing, as represented by the arrow "fluid flow." Liquid will then follow the only path  
25 available, and be collected into the external trap bottle 71. Valves 80B - 80D function similarly for their respective trap bottles 59. A small overflow trap bottle 83 is also inserted into the line with its own fluid sensor 93. This provision is included so as to detect if any of the trap bottles 59, or external trap bottle 71 are overflowing with waste liquid. In that case, liquid would enter the overflow trap  
30 bottle and be detected by the fluid sensor. That information would be

-15-

communicated to the controller 86, which would shut the system down and alert the instrument operator on the computer screen.

Referring to FIG. 13, the liquid handling zone also includes an air-mix head 69. A schematic representation of the air flow into the air-mix head 69 is shown in FIG. 15. The pump generates a high velocity air stream that is channeled into the air-mix head 69. Air intake to the pump is via the three way solenoid valve 81 (FIG. 15). The solenoid valve 81 (FIG. 15) switches so as to channel air directly from the atmosphere to the pump (FIG. 15), bypassing the aspiration system and trap bottles 59 and 71. The high velocity air flow is focused onto the slide. The air-mix head 69 travels back and forth along the length of the slide, pushed and pulled by a belt and pulley that is attached to a motor (not shown). The net effect of this system is to direct a curtain of air back and forth along the length of the slide, causing liquid to be mixed and spread along the surface of the microscope slide.

The liquid handling zone 65 (FIG. 12) includes a bulk liquid dispensing port 68 (FIG. 13). The function of the rinse tubes 28 of the first embodiment 1 (shown in FIG. 1) are all incorporated into a single bulk liquid dispensing port 68 in this preferred embodiment. Therefore, slides are positioned under the bulk liquid dispensing port 68 regardless of the bulk liquid bottle that the liquid is actually derived from. A schematic representation of the fluid pathways and control valves is shown in FIG. 16. The bulk liquid bottles 57 are each connected to a source of pressure, that is generated by a pump 85. The pressure is communicated to the bulk liquid bottles 57 via a pressure manifold 94. Solenoid valves 72a - 72f are placed between the bulk liquid dispensing port 68 and each bulk liquid bottle 57. Liquid flows out the bulk liquid dispensing port 68 only when one or more of the valves 72a - 72f are open. A pressure switch 84 also communicates with the pressure manifold 94. It is capable of sensing the amount or pressure contained within the manifold 94. When it falls below a specified level, it communicates with the controller 86 causing activation of the pump 85. As the pump generates an increased amount of air pressure within the pressure manifold, the pressure switch resets, causing the pump to stop pumping. In this manner, a relatively constant pressure head is maintained within the pressure manifold 94.

-16-

A dispense sensor 95 is positioned underneath the bulk liquid dispensing port 68 to provide verification that liquid was dispensed when one of the solenoid valves 72a - 72f were transiently opened. The dispense sensor 95 comprises an optical sensor and an LED light source. When liquid is dispensed from the bulk liquid dispensing port 68, the liquid interrupts the light beam. The change in resistance across the sensor as a result of the decrement in light intensity is communicated to the controller 86.

This second, preferred embodiment of the invention includes the capability to independently heat the forty-nine slides to different temperatures. A novel aspect of this embodiment is the method for independently regulating the amount of power that each of the forty-nine heaters receives. Moreover, each heater also incorporates a temperature sensor. Each of these sensors must communicate with the computer 86 in order to allow for appropriate temperature feedback and regulation. In the first embodiment 1, groups of up to five slides were under a single, common temperature control mechanism. Each heating group had wires that directly connected with the temperature controller (FIG. 7). With three wires per group (power for heat, sensor feedback, and a shared ground) and ten groups of slides, at least thirty wires were contained in the service loop. If a similar system were used for forty-nine different heaters, as in this preferred embodiment, 147 wires would be required in the service loop. Such a bulky service loop would be problematic. Therefore, an alternative method is developed in this preferred embodiment.

FIG. 17 shows the relationship between each of the heating elements 78 mounted on the slide rotor 77, depicting the heating element 78 as a resistive element. A single sensor 87 is adjacent to each heater. The combination of a single heating element 78 and sensor 87 are so positioned so as to provide a location 88 for a single slide to be heated. The physical layout of this location 88 is demonstrated in FIGS. 14A and 14B. Two wire leads from each heating element 78, and two wire leads from each sensor 87 are connected directly to a temperature control board mounted on the slide rotor 77. Each temperature control board is capable of connecting to up to eight different heater and sensor pairs. Since this embodiment incorporates forty-nine slide positions, seven boards 79 are mounted to the underside

-17-

of the slide rotor, each connecting to seven heater-sensor pairs. One heater-sensor position per temperature controller board 79 is not used. Also shown in FIG. 17 is the serial connection 89 of each of the seven temperature control boards, in a daisy-chain configuration, by six wires. The first temperature control board is  
5 connected via a service loop 90 to the computer 86 (FIG. 16) which serves as the user interface and system controller. The service loop contains only six wires.

FIGs. 18A-D are an electronic schematic diagram of the temperature control board 79. The design of the temperature control board 79 was driven by the need to minimize the number of wires in the flexible cable (service loop 90) between the  
10 heaters and the computer. To minimize the length of wires, seven temperature controller boards 79 are used, each mounted on the slide rotor. Thus, each heater is positioned close to its associated electronics and the size of each board 79 is kept small because each runs only seven heating elements 78. Each temperature controller board 79 includes the function of an encoder and decoder of temperature  
15 data. That data relates to the actual and desired temperature of each of heating elements 78. The data flows back and forth between the computer 86 and the temperature control board 79. If an individual heating element 79 requires more or less heat, the computer communicates that information to the temperature control board 79. The temperature control board 79, in turn, directly regulates the amount  
20 of power flowing to each heater. By placing some of the logic circuitry on the slide rotor, in the form of the temperature control boards 79, the number of wires in the service loop 90, and their length, are minimized.

In this embodiment, the temperature control board 79 system was designed as a shift register. The machine's controlling microprocessor places bits of data one  
25 at a time on a transmission line, and toggles a clock line for each bit. This causes data to be sent through two shift register chips U1 and U2 on each control board, each taking eight bits. There are thus 16 x 7 or 112 bits to be sent out. Referring to FIGs. 18A-D, the data comes in on connector J9.1, and the clock line is J9.2. The shift registers used in this design are "double buffered," which means that the output  
30 data will not change until there is a transition on a second clock (R clock), which comes in on pin J9.3. The two clocks are sent to all seven boards in parallel, while

-18-

the data passes through the shift register chips (U1 and U2) on each board and is sent on from the second shift register's "serial out" pin SDOUT to the input pin of the next board in daisy chain fashion. It will be seen that a matching connector, J10, is wired in parallel with J9 with the exception of pin 1. J10 is the "output" connector, which attaches via a short cable to J9 of the next board in line, for a total of seven boards. The other three pins of J9 are used for power to run the electronics (J9.4), electronic ground (J9.5), and a common return line (J9.6) for temperature measurement function from the sensors.

Of the sixteen data bits sent to each board, eight from register U2 control the on/off status of up to eight heating elements 78 directly. This can be accomplished with a single chip because shift register U2 has internal power transistors driving its output pins, each capable of controlling high power loads directly. Four of the remaining eight bits are unused. The other four bits are used to select one thermistor 87 out of the machine's total complement of forty-nine. For reasons of economy and to reduce the amount of wiring, the instrument has only one analog-to-digital converter for reading the forty-nine temperature transducers (thermistors 87), and only one wire carrying data to that converter. This channel must therefore be shared between all of the transducers (thermistors 87), with the output of one of them being selected at a time. Component U4 is an analog multiplexer which performs this function. Of the four digital bits which are received serially, one is used to enable U4, and the other three are used to select one of the component's eight channels (of which only seven are used). If pin four is driven low, U4 for that board 79 becomes active and places the voltage from one of the seven channels of that board on the shared output line at J9.6. Conversely, if pin four is pulled high, U4's output remains in a high impedance state and the output line is not driven. This allows data from a selected board 79 to be read, with the remaining boards 79 having no effect on the signal. Multiplexer U4 can only be enabled on one board 79 at a time; if more than one were turned on at a time, the signals would conflict and no useful data would be transmitted.

Temperature sensing is accomplished by a voltage divider technique. A thermistor 87 and a fixed resistor (5.6 kilohms, R1 - R8, contained in RS1) are

PCT/US99/04093

-19-

placed in series across the 5 volt electronic power supply. When the thermistor is heated, its resistance drops and the voltage at the junction point with the 5.6 kilohm resistor will drop.

There are several advantages to the design used in this embodiment. Namely, the temperature control boards 79 are small and inexpensive. Moreover, the heater boards are all identical. No "address" needs to be set for each board 79. Lastly, the service loop 90 is small in size.

An alternative potential design is that each temperature control board 79 could be set up with a permanent "address" formed by adding jumper wires or traces cut on the board. The processor would send out a packet of data which would contain an address segment and a data segment, and the data would be loaded to the board whose address matched the address sent out. This approach takes less time to send data to a particular board, but the address comparison takes extra hardware. It also demands extra service loop wires to carry the data (if sent in parallel) or an extra shift register chip if the address is sent serially. Yet another potential design is that each temperature control board 79 could have its own microprocessor. They could all be connected via a serial data link to the main computer 86. This approach uses even fewer connecting wires than the present embodiment, but the cost of hardware is high. It also still implies an addressing scheme, meaning that the boards would not be identical. Also, code for the microprocessors would be required.

PCT/US99/04093

-20-

## CLAIMS

What is claimed is:

1. A slide stainer comprising:
  - a slide support (77) adapted to support at least one microscope slide in a horizontal position to retain liquid on its surface;
  - a source of vacuum (82); and
  - an aspiration head (67) in fluid continuity with the source of vacuum;
  - characterized by:
    - an actuator (73) which causes the aspiration head to contact the liquid on the slide surface;
    - more than one liquid waste collection container (59) positioned between and in fluid connection with the aspiration head and the source of vacuum; and
    - a liquid director (80A-80D) which directs liquid waste to collect in a selected liquid waste collection container.
2. A slide stainer as claimed in claim 1, wherein the surface of the aspiration head that contacts the liquid on the slide is essentially planar.
3. A slide stainer as claimed in claim 2, wherein the aspiration head has more than one aperture through which to aspirate liquid.
4. A slide stainer as claimed in claim 1 or 2, wherein the planar surface contacts the liquid on the slide but does not contact the slide surface.
5. A slide stainer as claimed in claim 2, wherein the planar surface is essentially parallel to the microscope slide when the application head is caused to contact the liquid on the slide surface.

PCT/US99/04093

-21-

6. A slide stainer as claimed in claim 1, wherein the aspiration head comprises a hollow manifold (74).
7. A slide stainer as claimed in claim 1, wherein a plurality of slides are mounted in a horizontal position and further comprising a controller (86) for selecting from which slide liquid is to be aspirated.
8. A slide stainer as claimed in claim 1, wherein the plurality of slides are mounted on a rotary carousel (77) and an aspiration head is provided in a fixed location on the periphery of said rotary carousel.
9. A liquid aspiration system for removing liquids from a microscope slide comprising:
- a microscope slide (17, 75) from which liquid is to be aspirated;
  - a source of vacuum (82); and
  - a hollow chamber (40, 74) with an attachment to the source of vacuum; characterized by:
    - a flat surface on the exterior of said hollow chamber having at least one hole (41) communicating between the exterior and interior of said hollow chamber;
    - an actuator (54, 73) which causes said flat surface to contact liquid on the microscope slide;
10. A liquid aspiration system as claimed in claim 9, wherein the flat surface on the exterior of the hollow chamber has approximately the same surface area as the microscope slide from which liquid is being aspirated.
11. A liquid aspiration system as claimed in claim 9, wherein at least one trap container (59) is connected between the liquid aspiration head and the source of vacuum.

PCT/US99/04093

-22-

12. A liquid aspiration system, as claimed in claim 11, wherein a plurality of trap containers (59) are provided for selectively collecting liquid waste into a desired trap container.
13. A method of aspirating liquid from the surface of a microscope slide comprising:  
5 providing a source of vacuum (82); and  
channeling that vacuum to an aspiration head (67);  
characterized by:  
moving the aspiration head so as to cause it to contact the liquid on  
the surface of a microscope slide; and  
10 collecting the liquid into a selected one of a plurality of containers  
(59).
14. A method of claim 13 wherein the aspiration head has a flat surface with plural aspirating apertures therein.

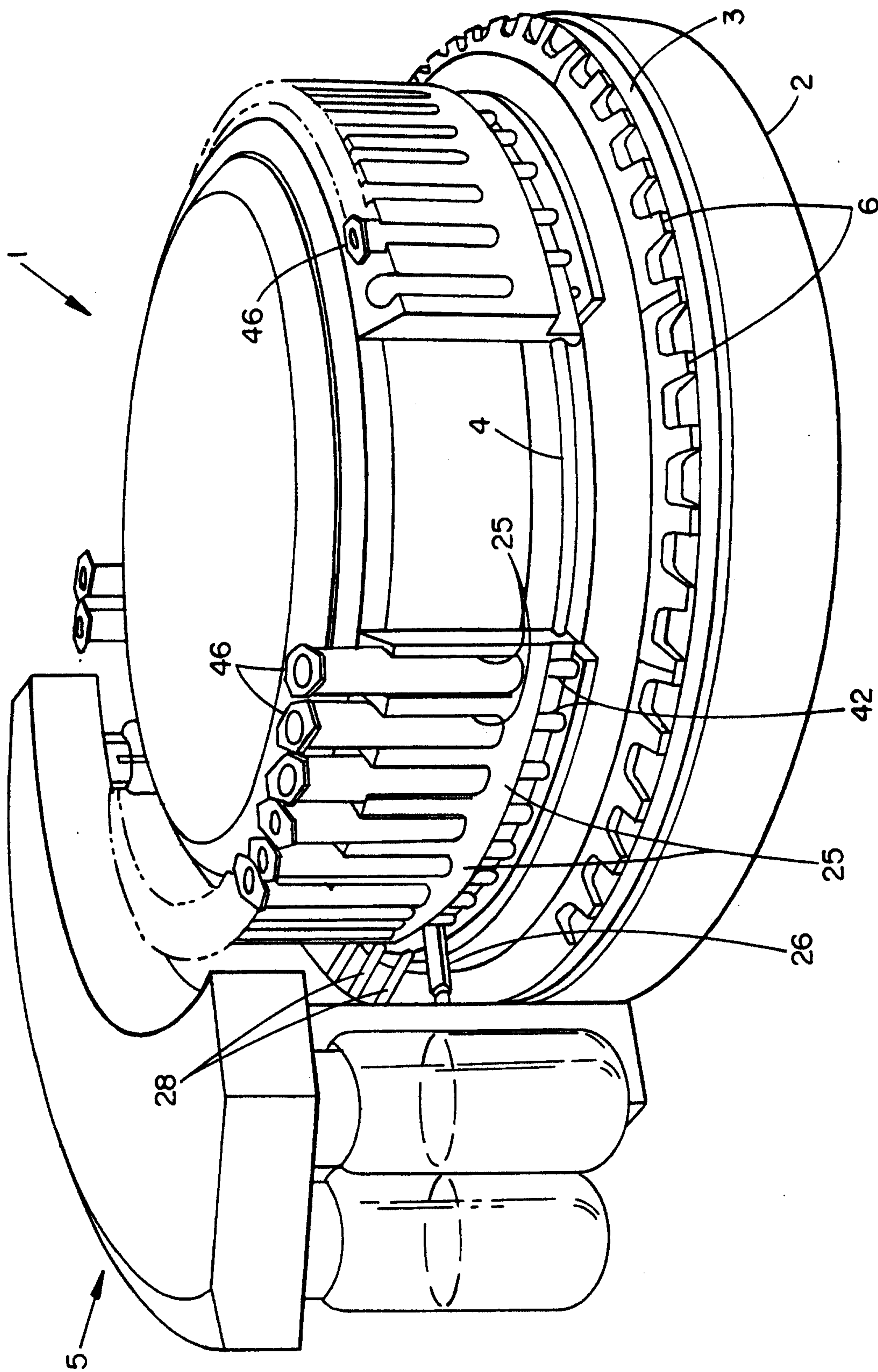

FIG. 1

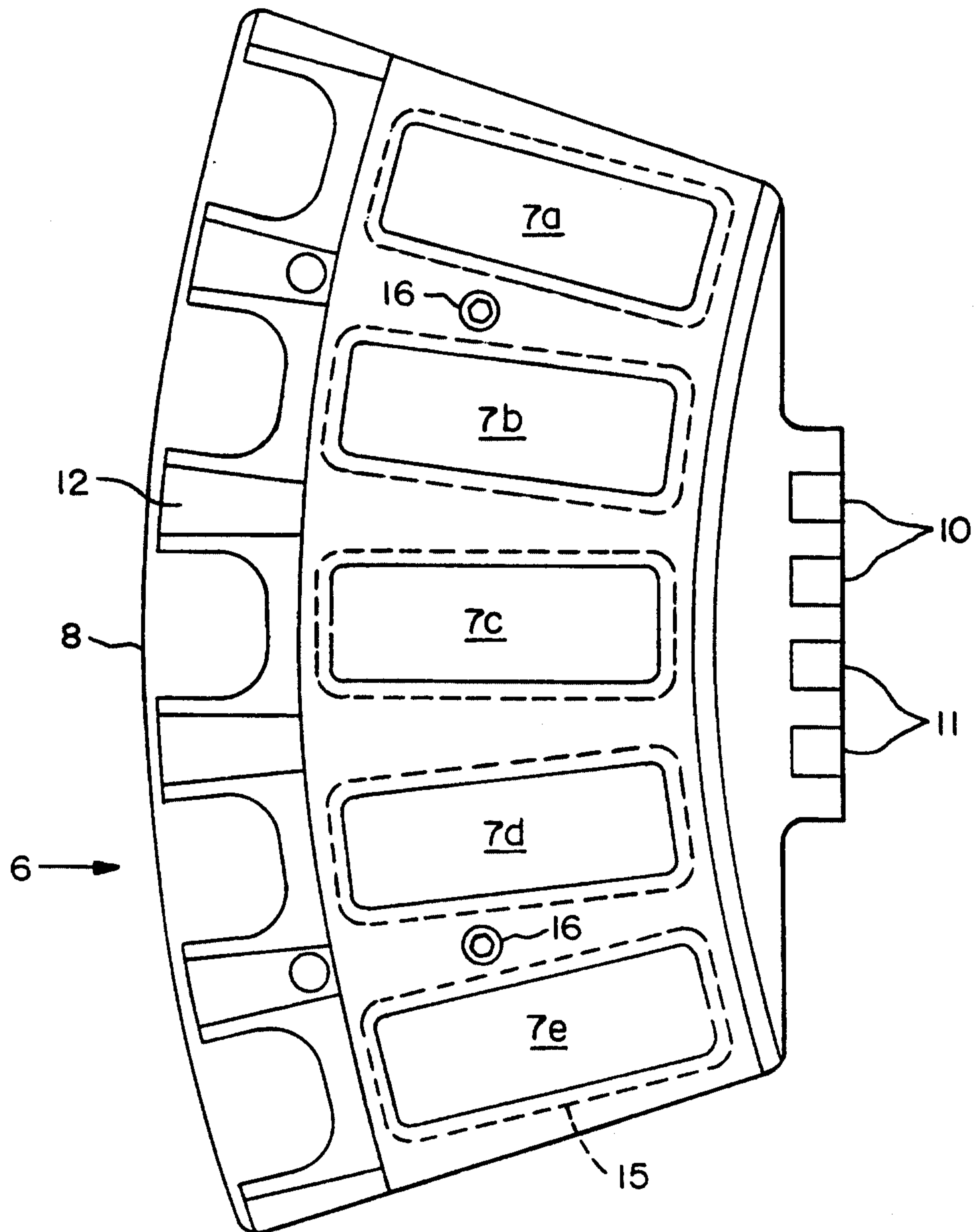

FIG. 2

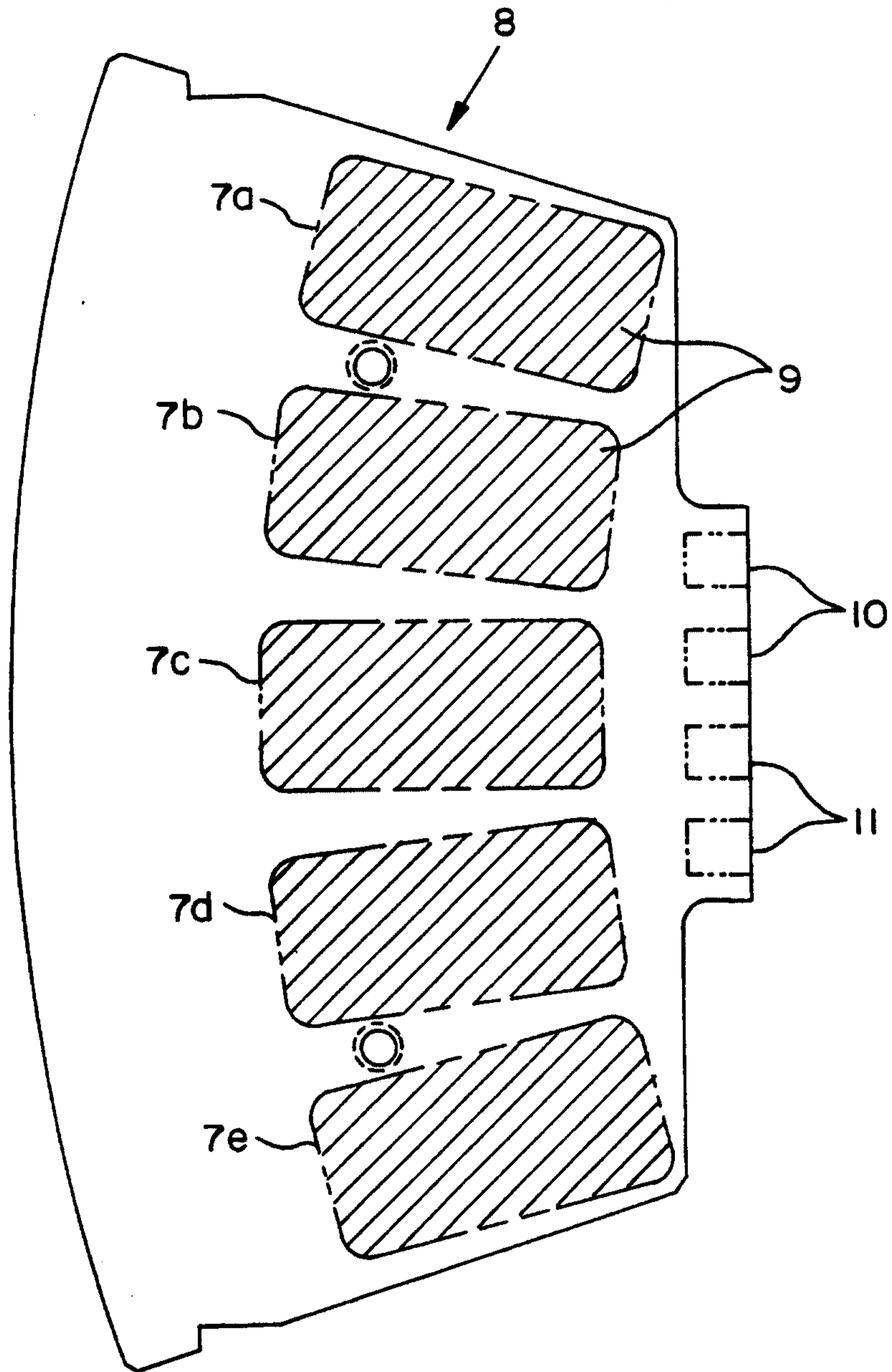

FIG. 3

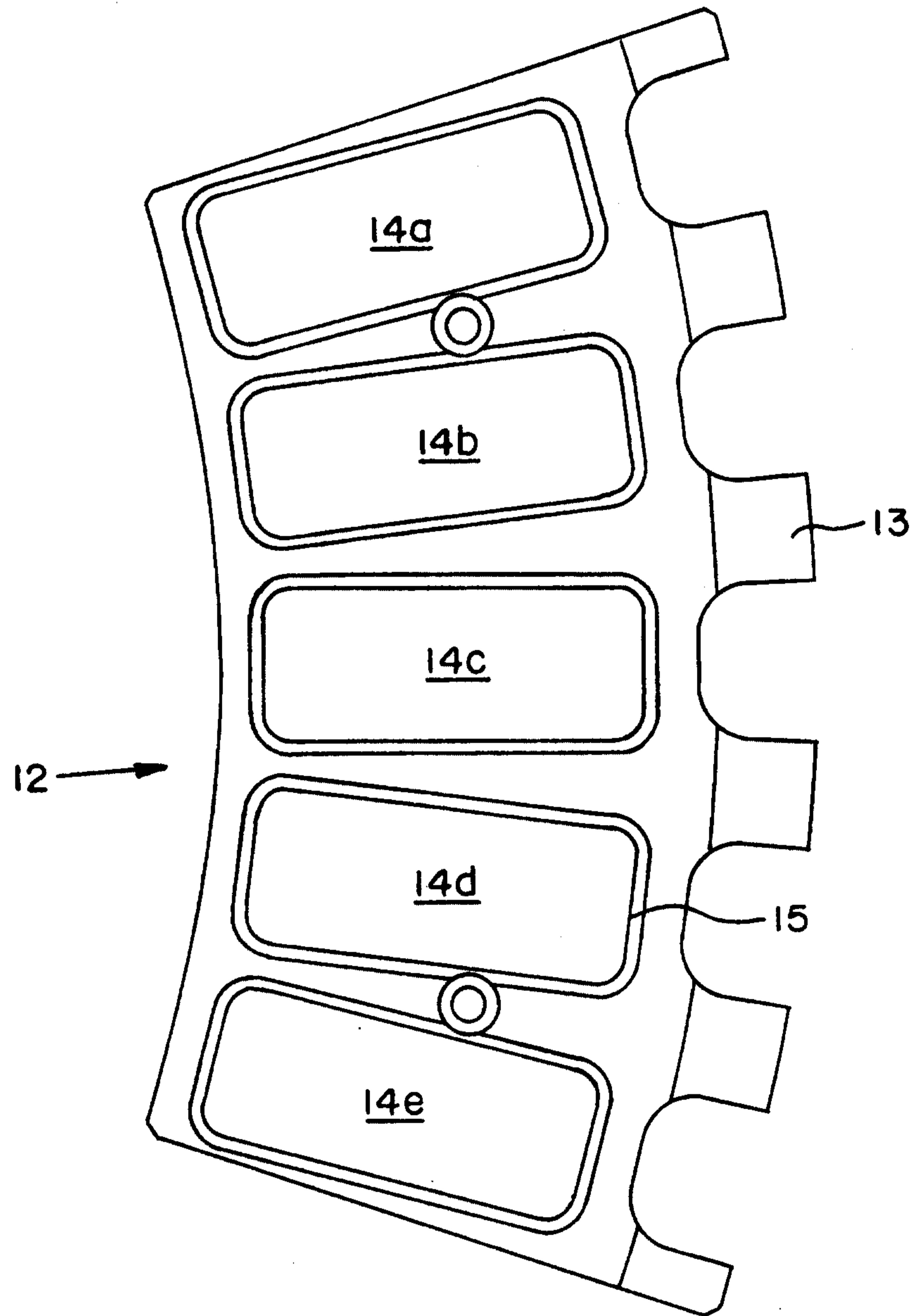

FIG. 4

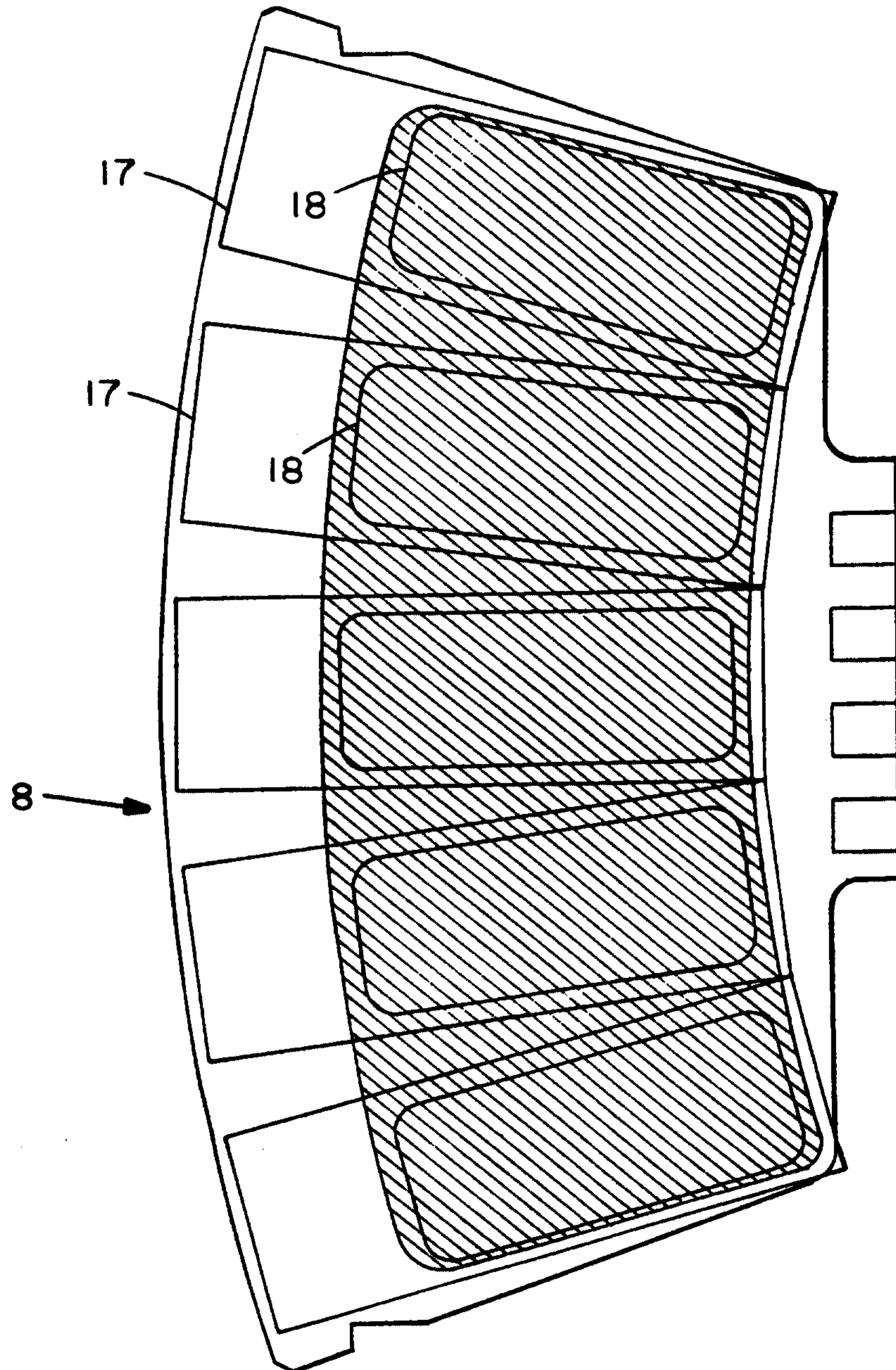

FIG. 5

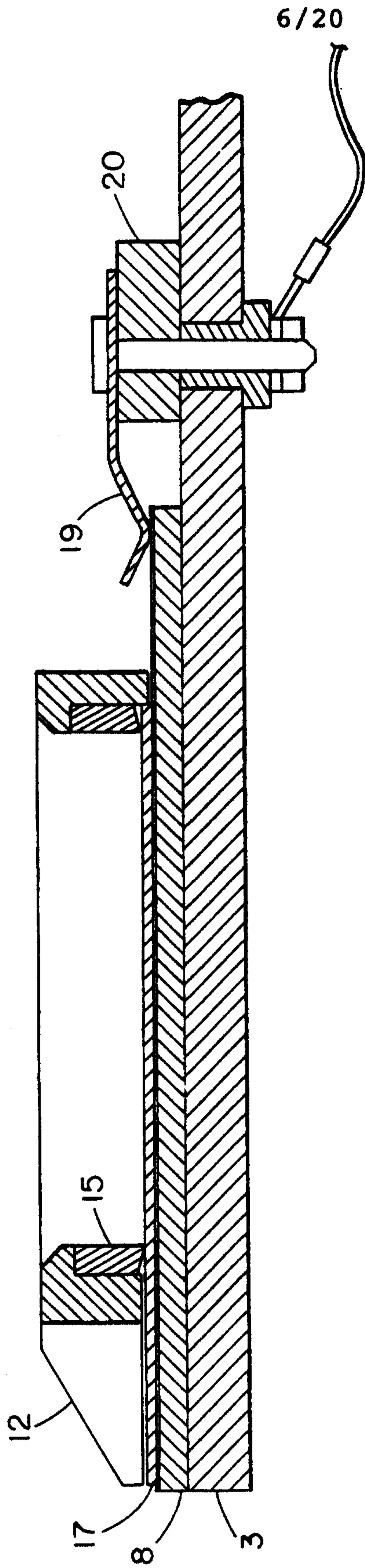

FIG. 6

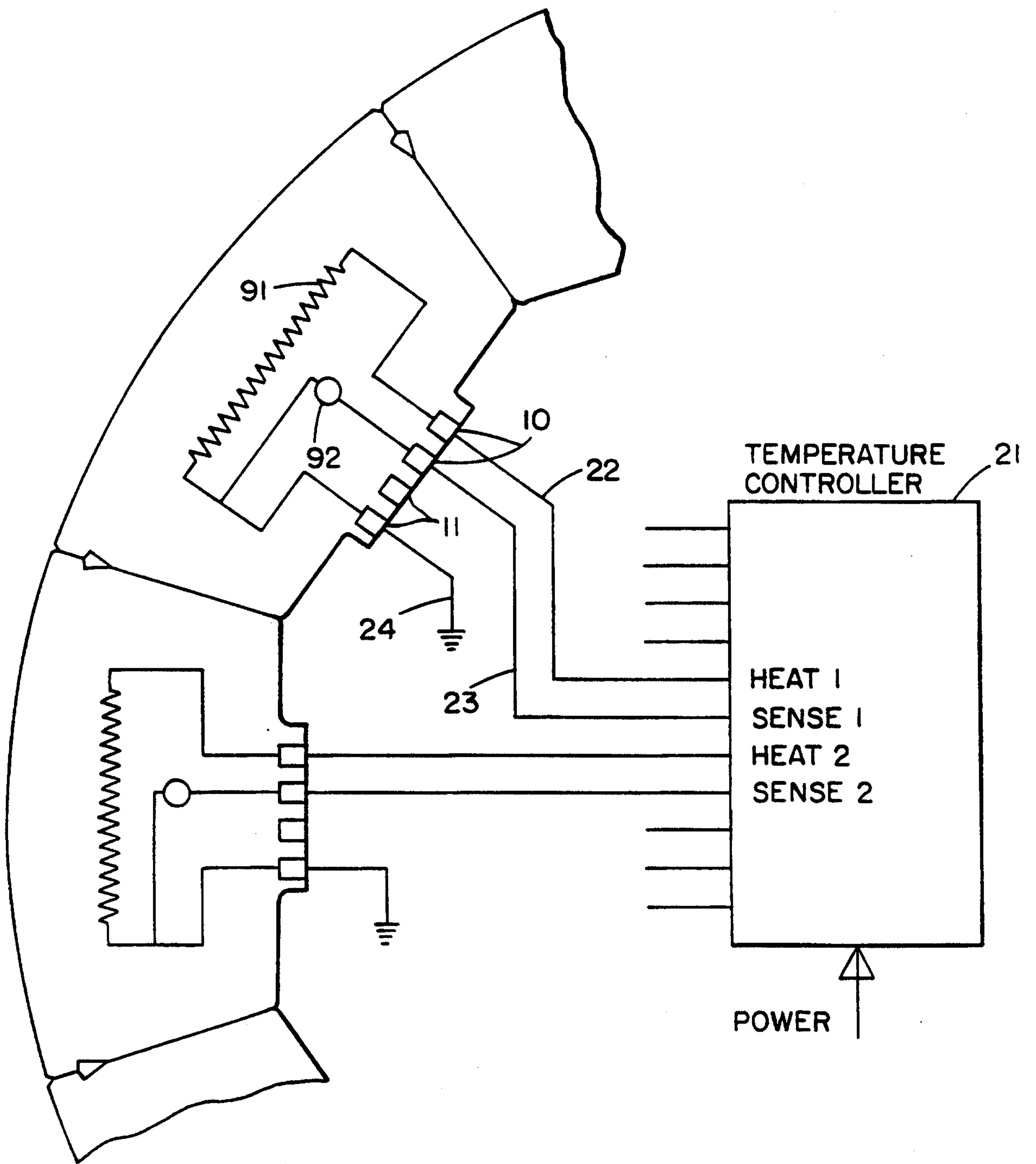

FIG. 7

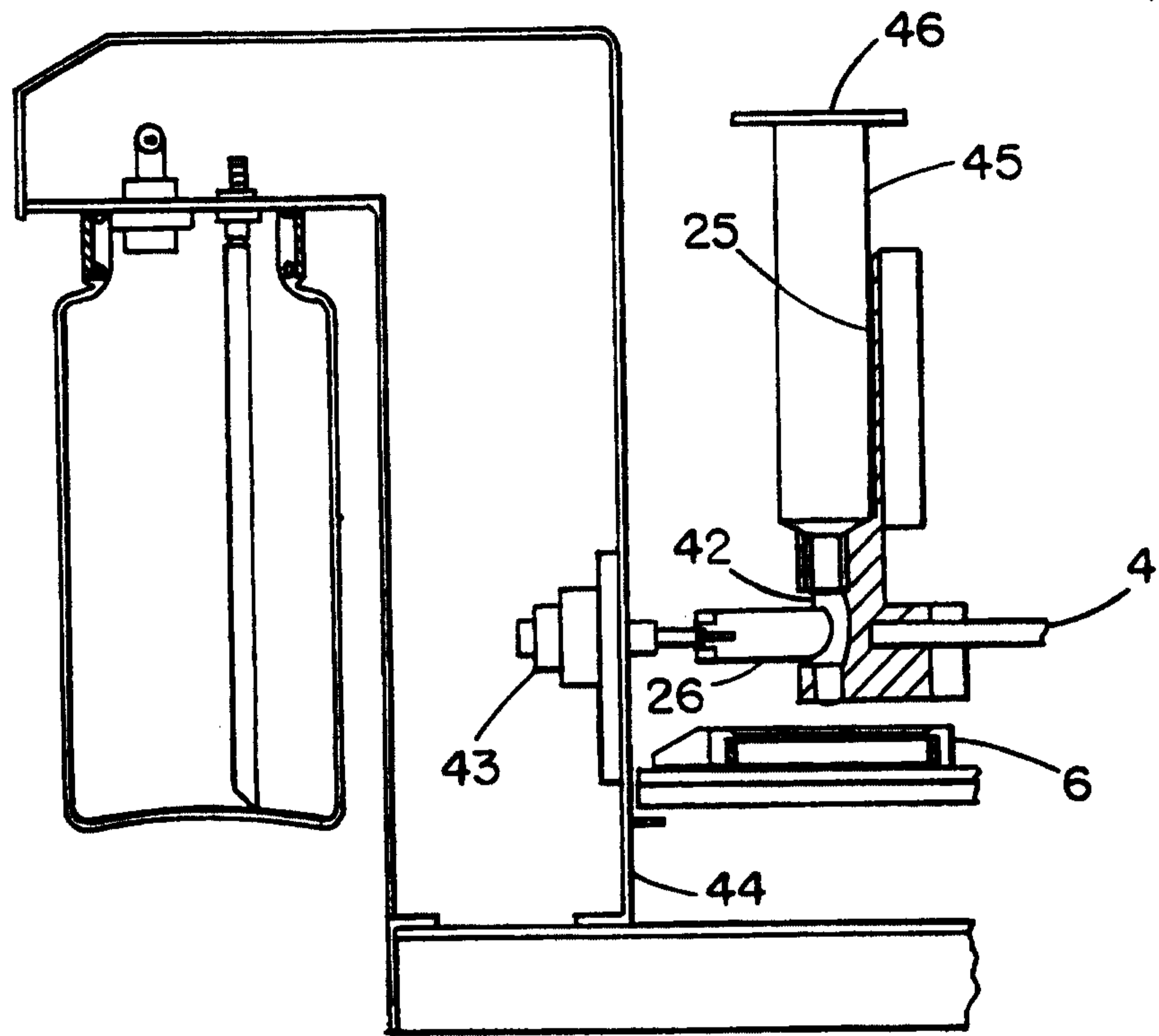

FIG. 8

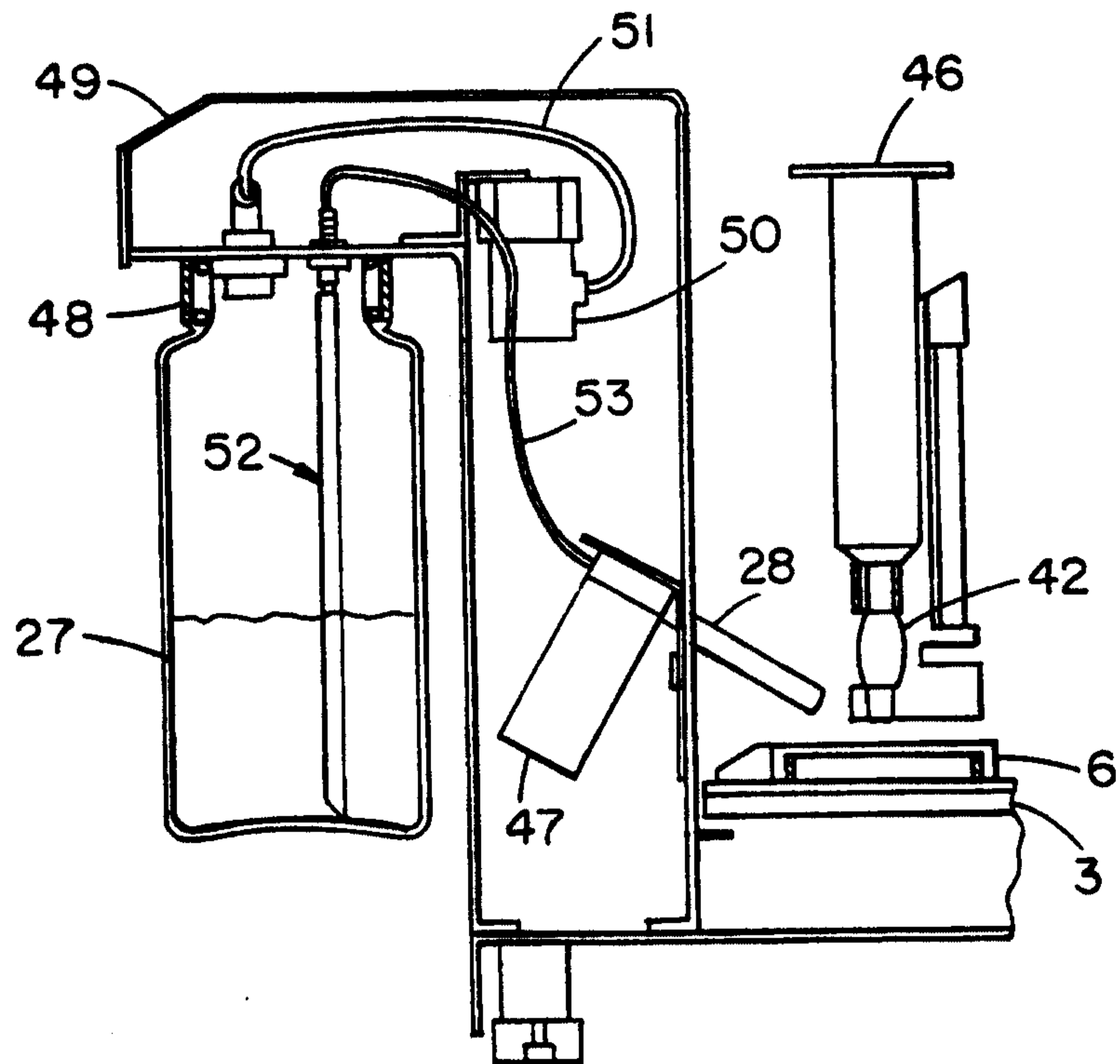

FIG. 9

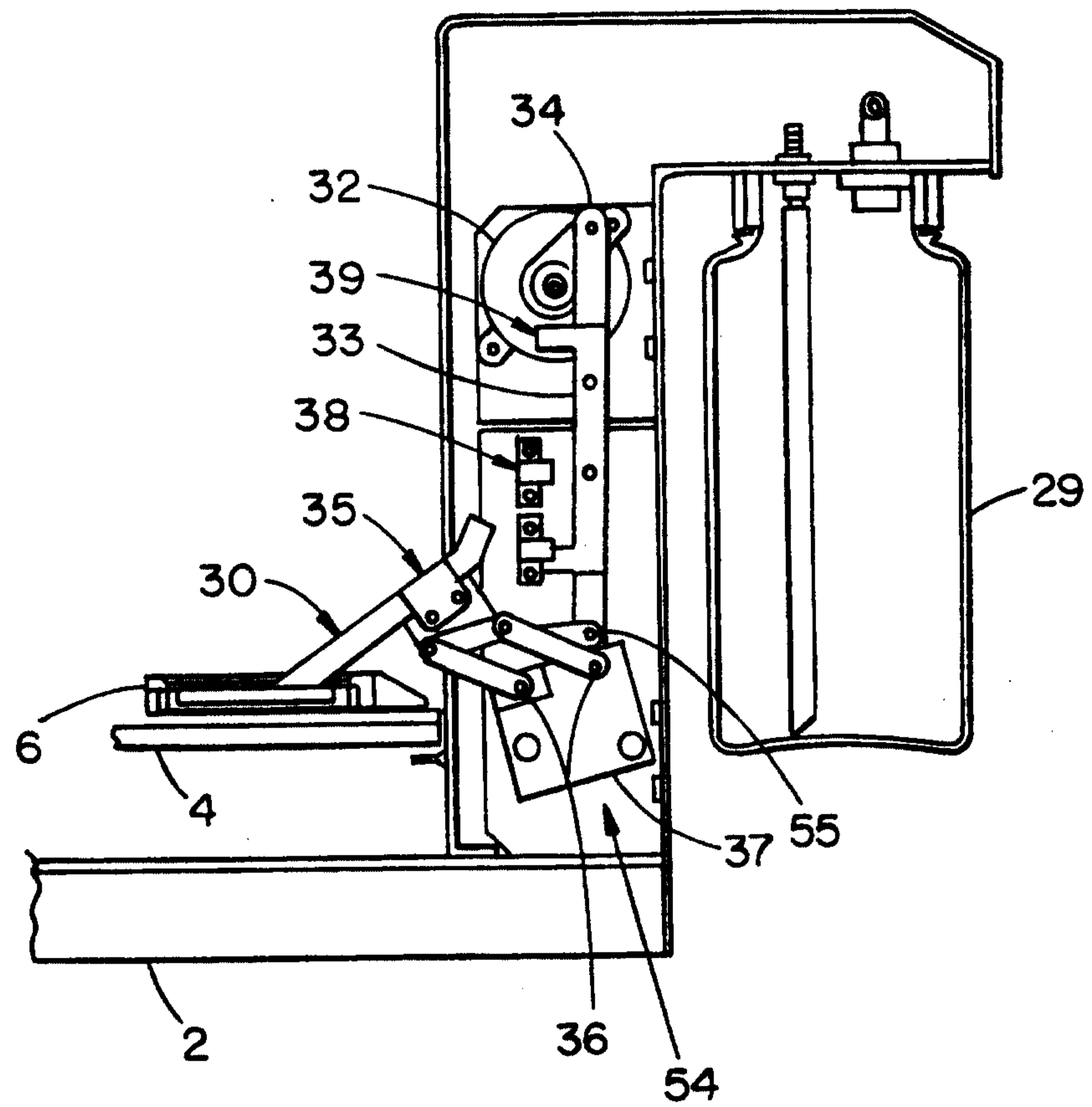

FIG. 10A

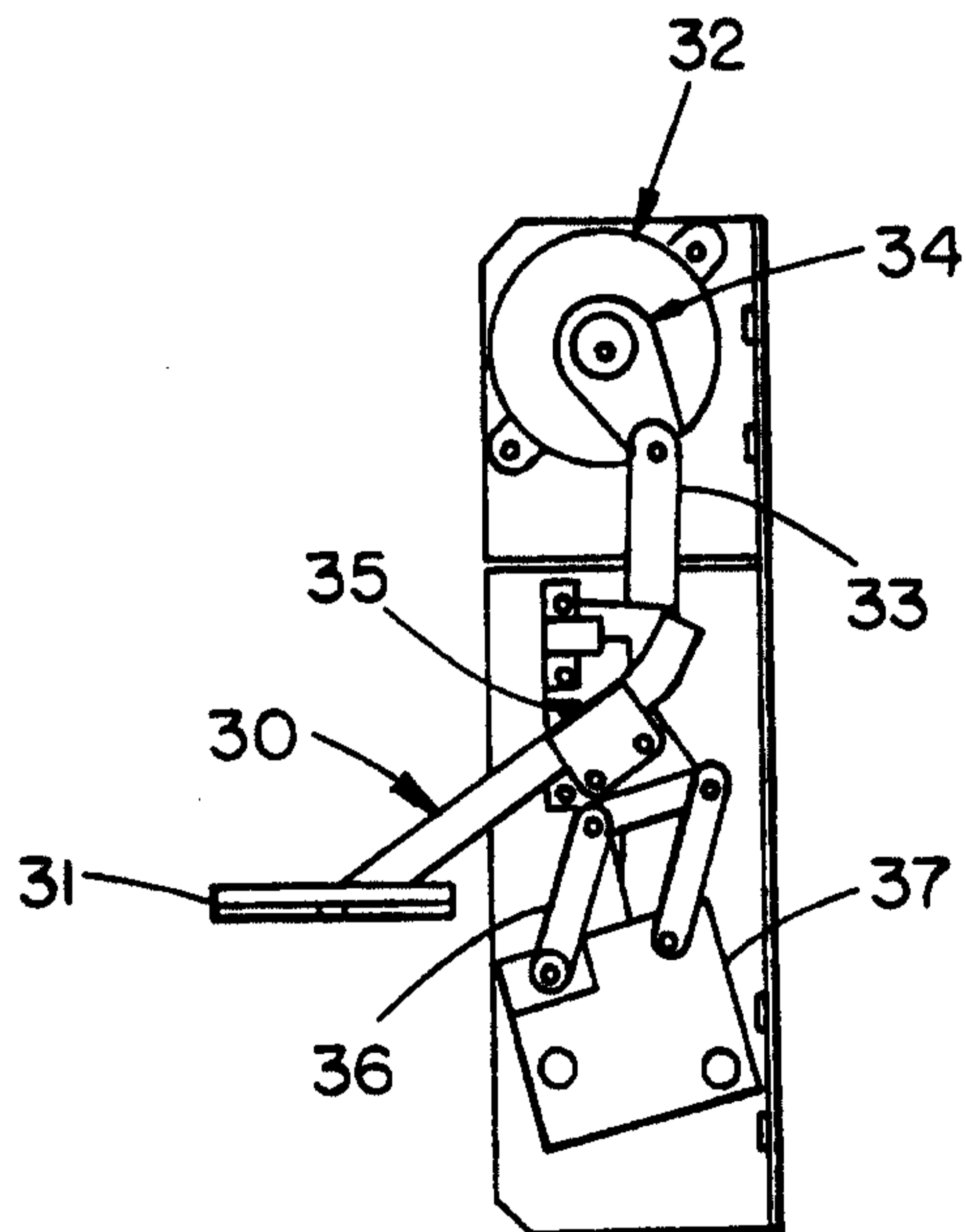

FIG. 10B

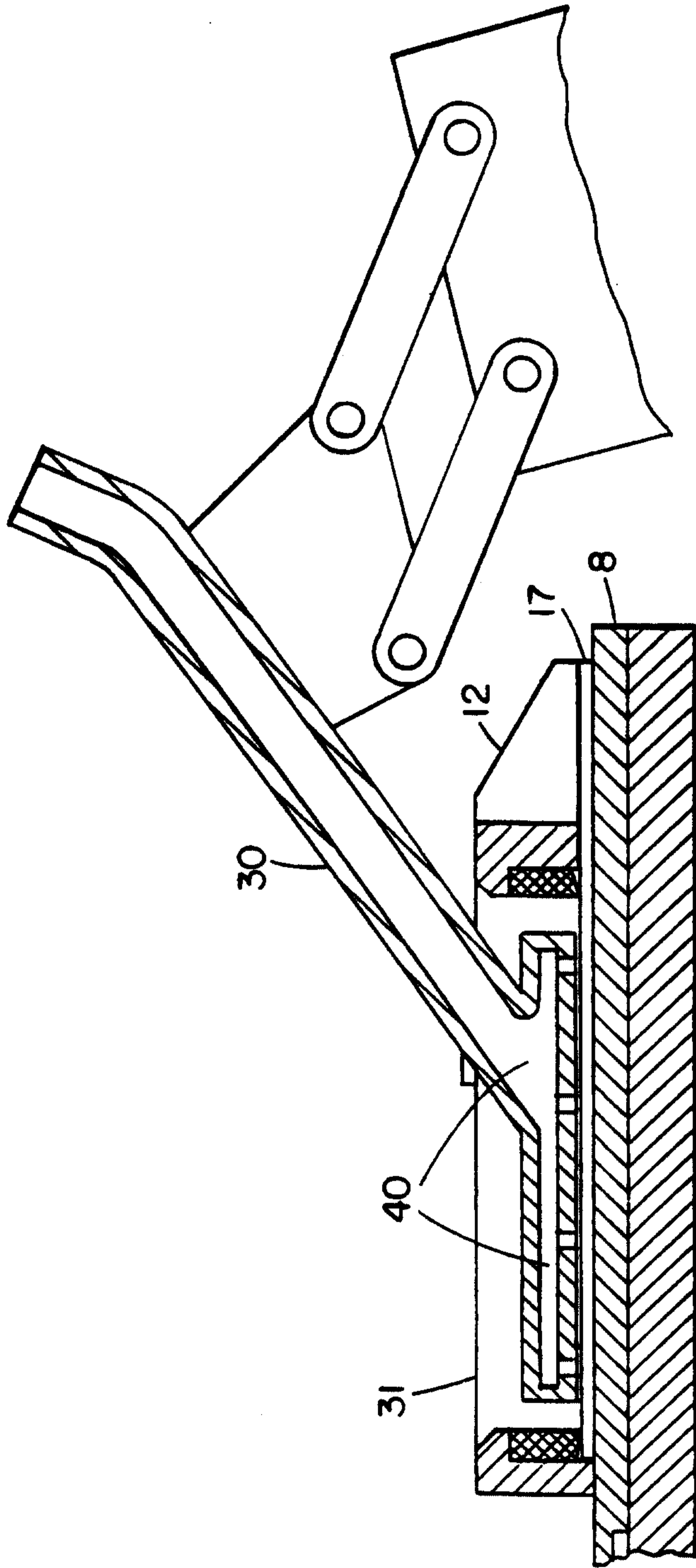

FIG. IIA

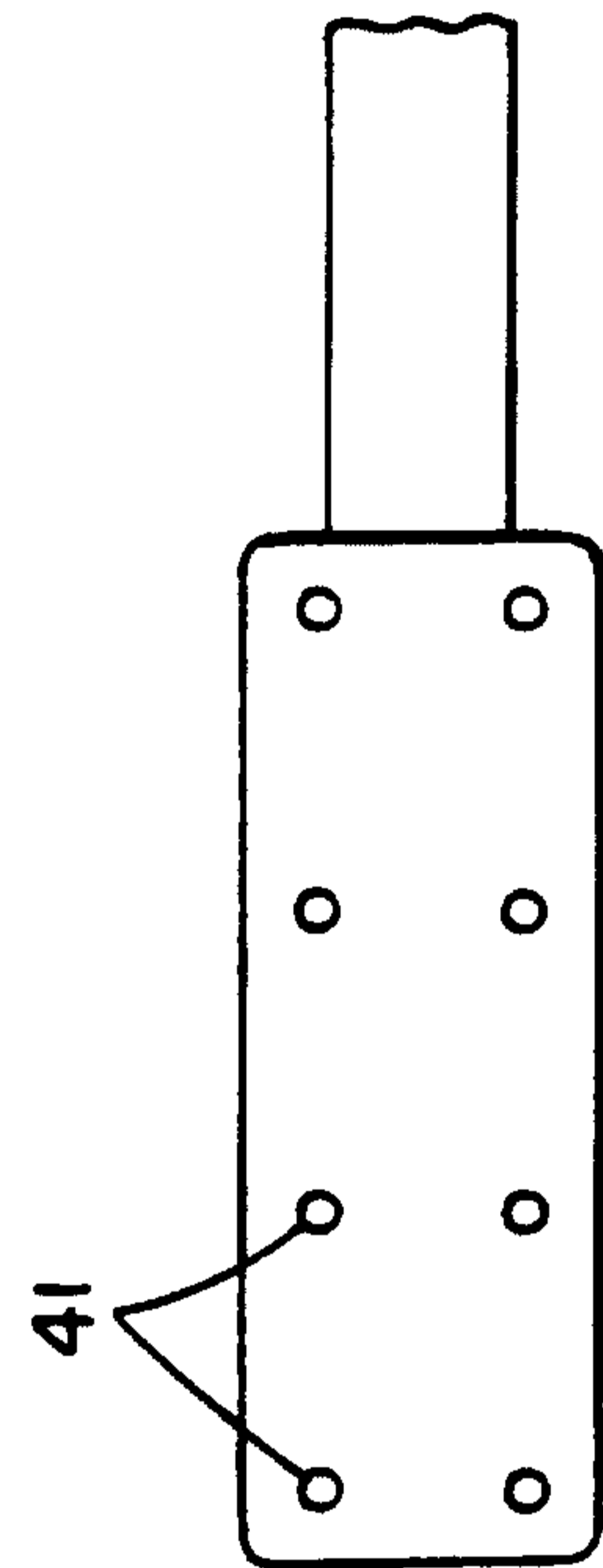

FIG. IIB

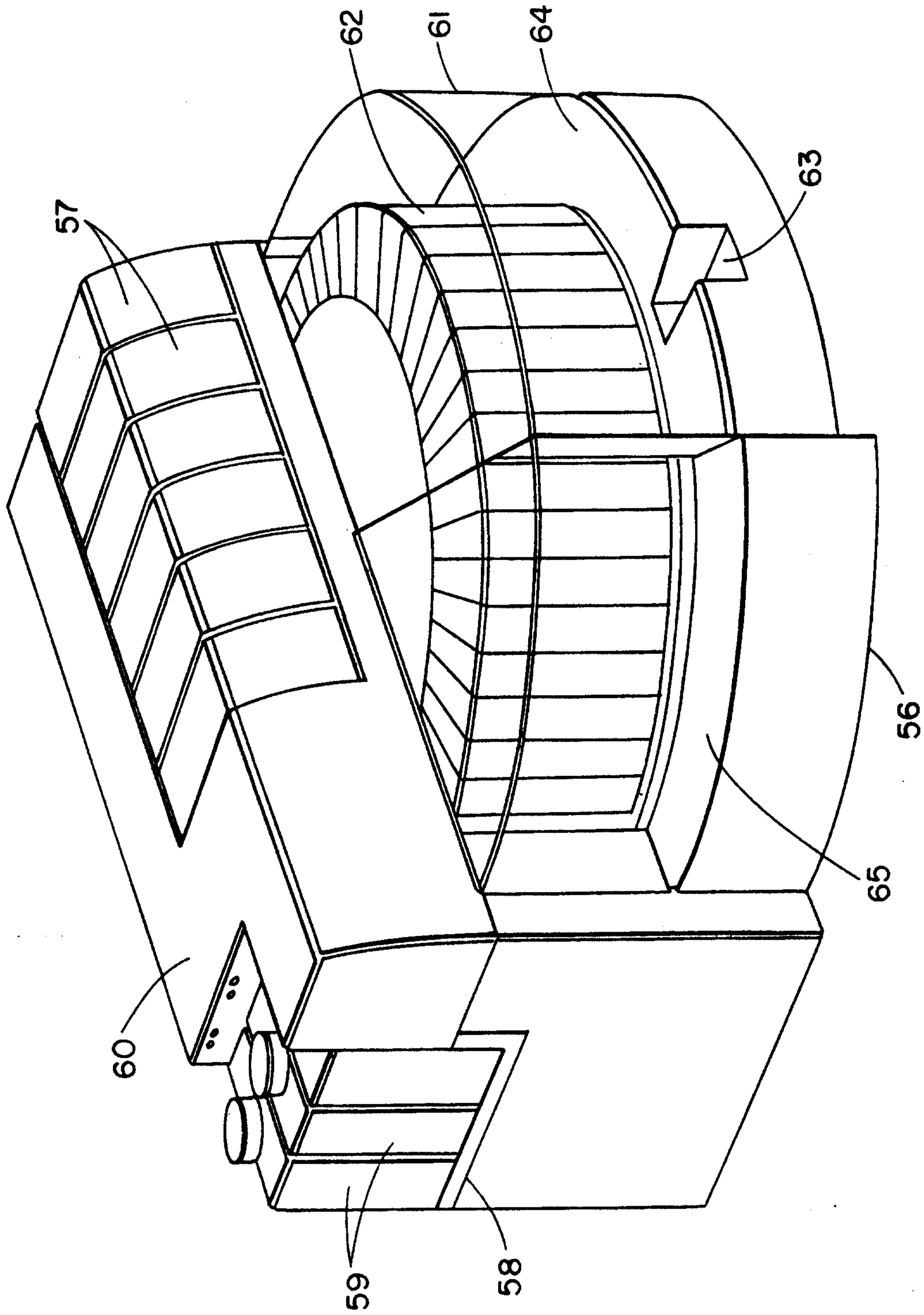

FIG. 12

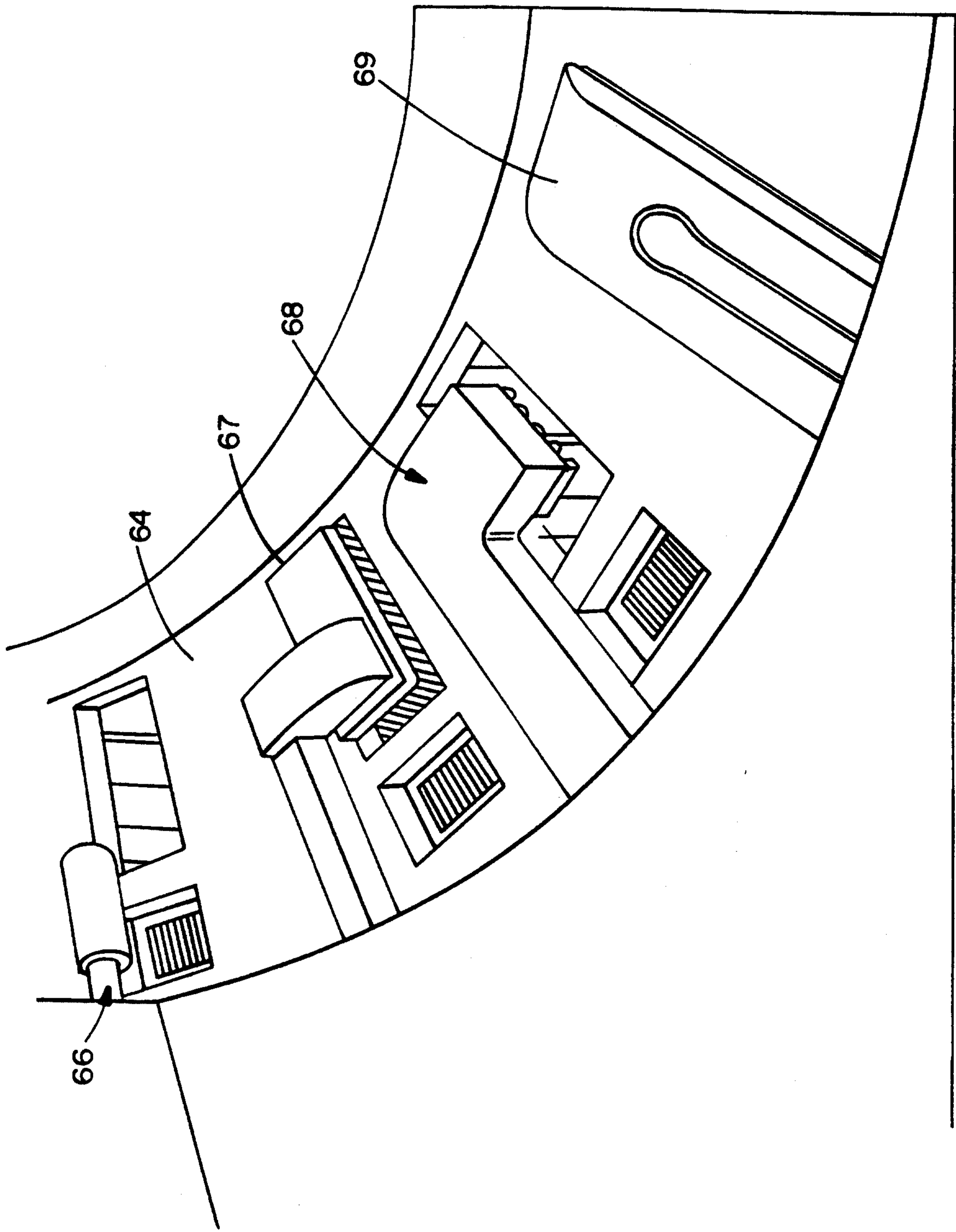

FIG. 13

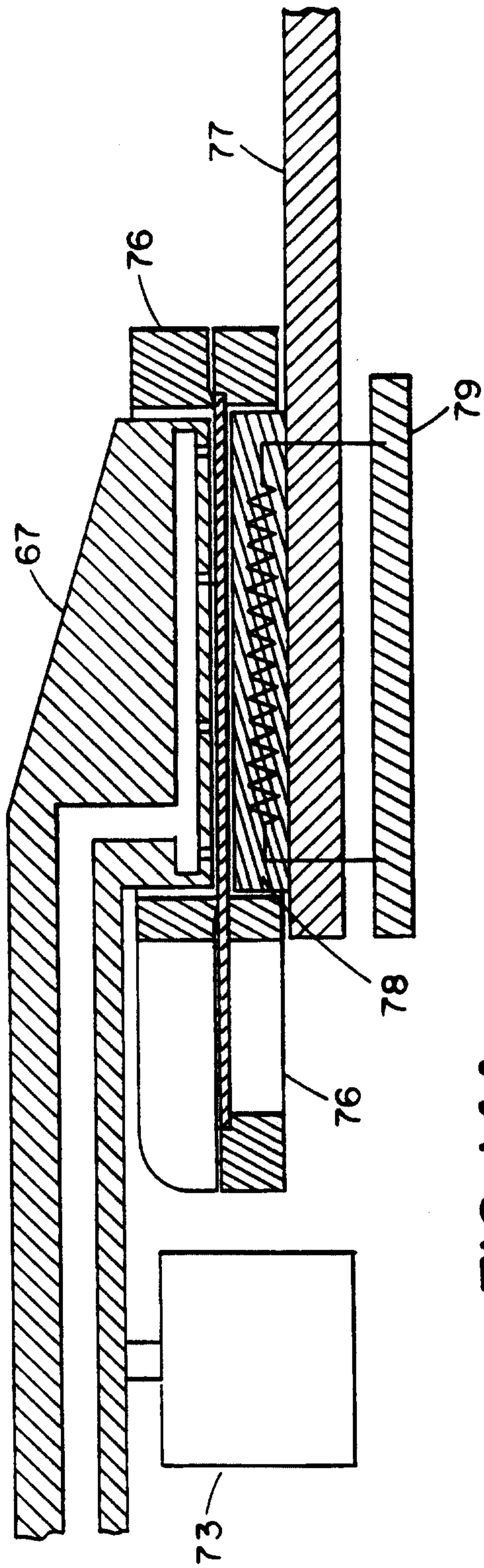

FIG. 14A

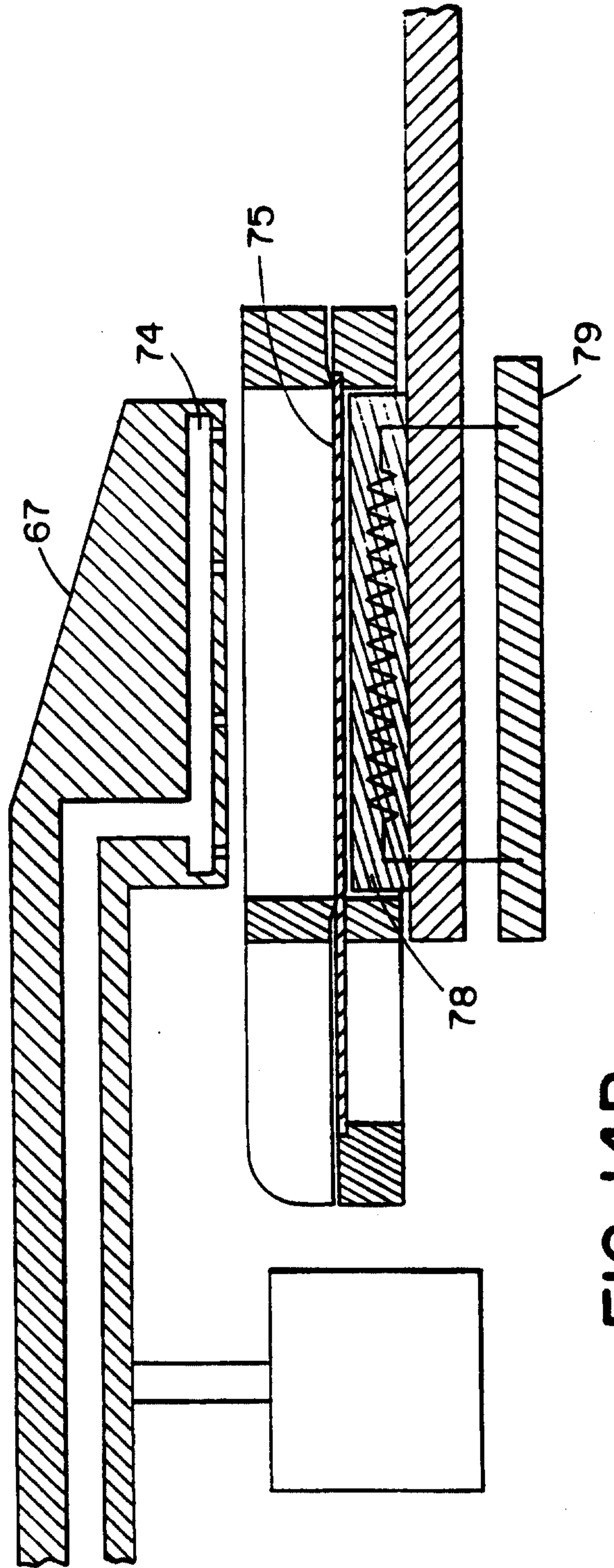

FIG. 14B

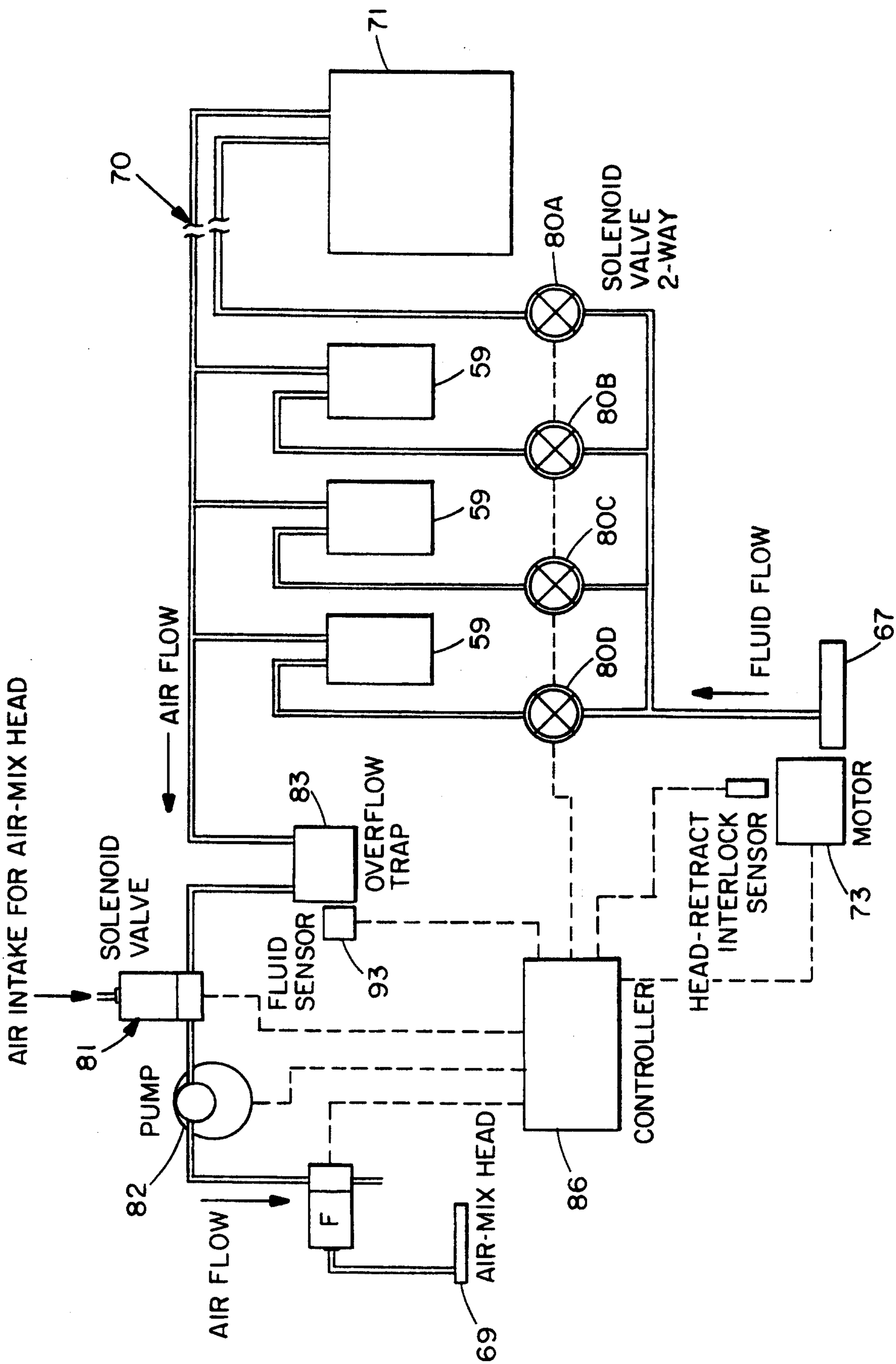

FIG. 15

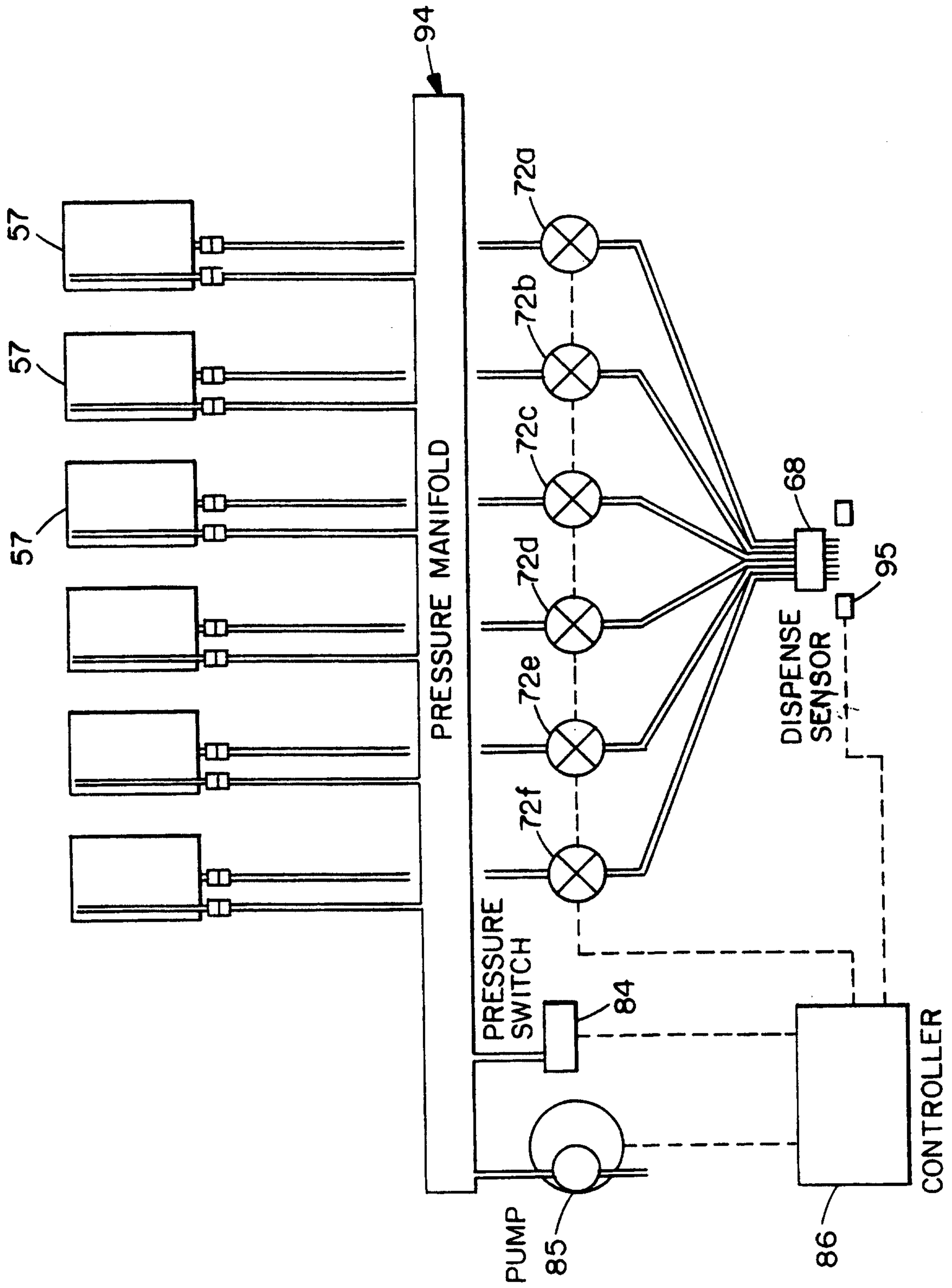

FIG. 16

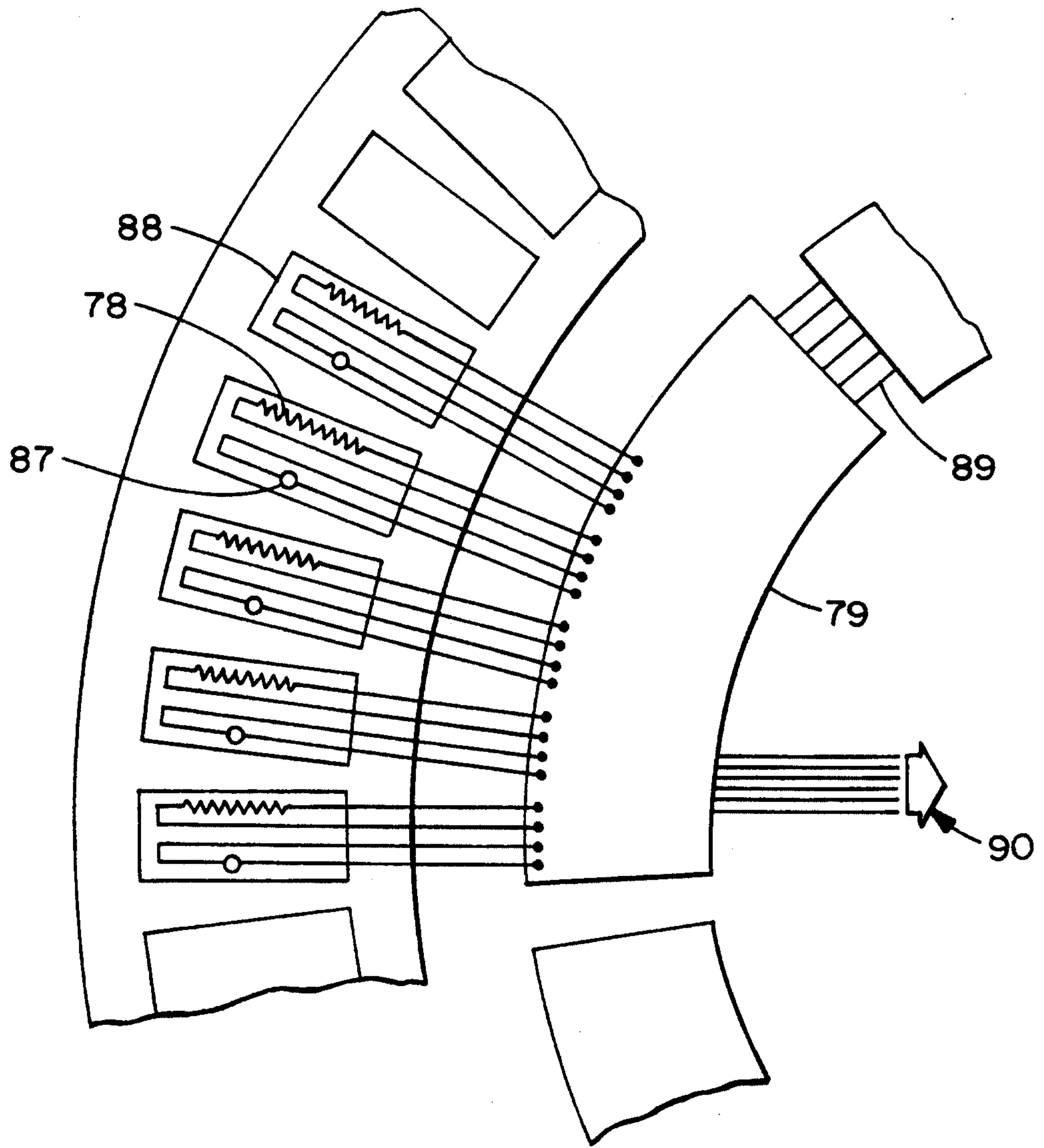

FIG. 17

FIG. 18A

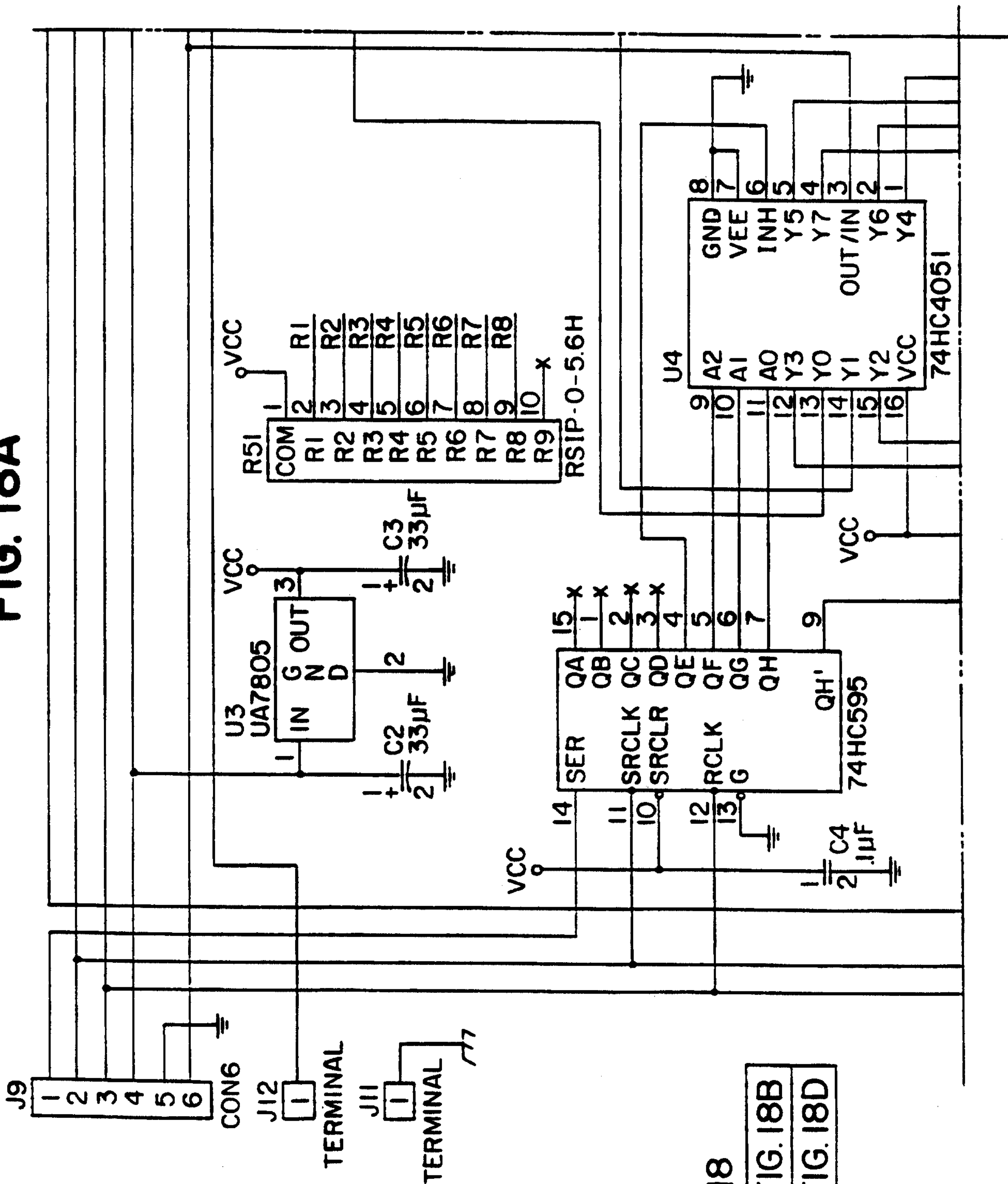
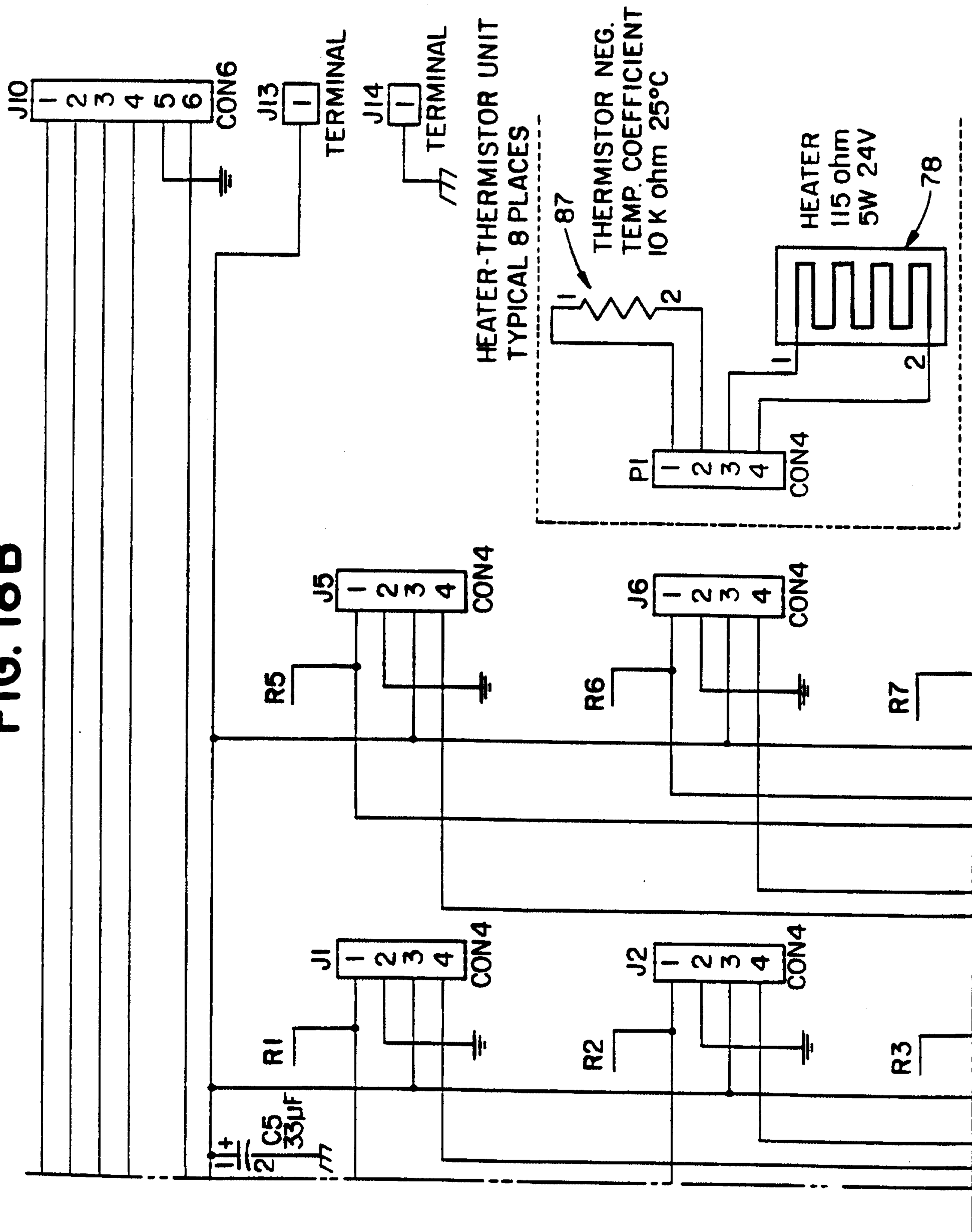

FIG. 18

FIG. 18A	FIG. 18B
FIG. 18C	FIG. 18D

FIG. 18B



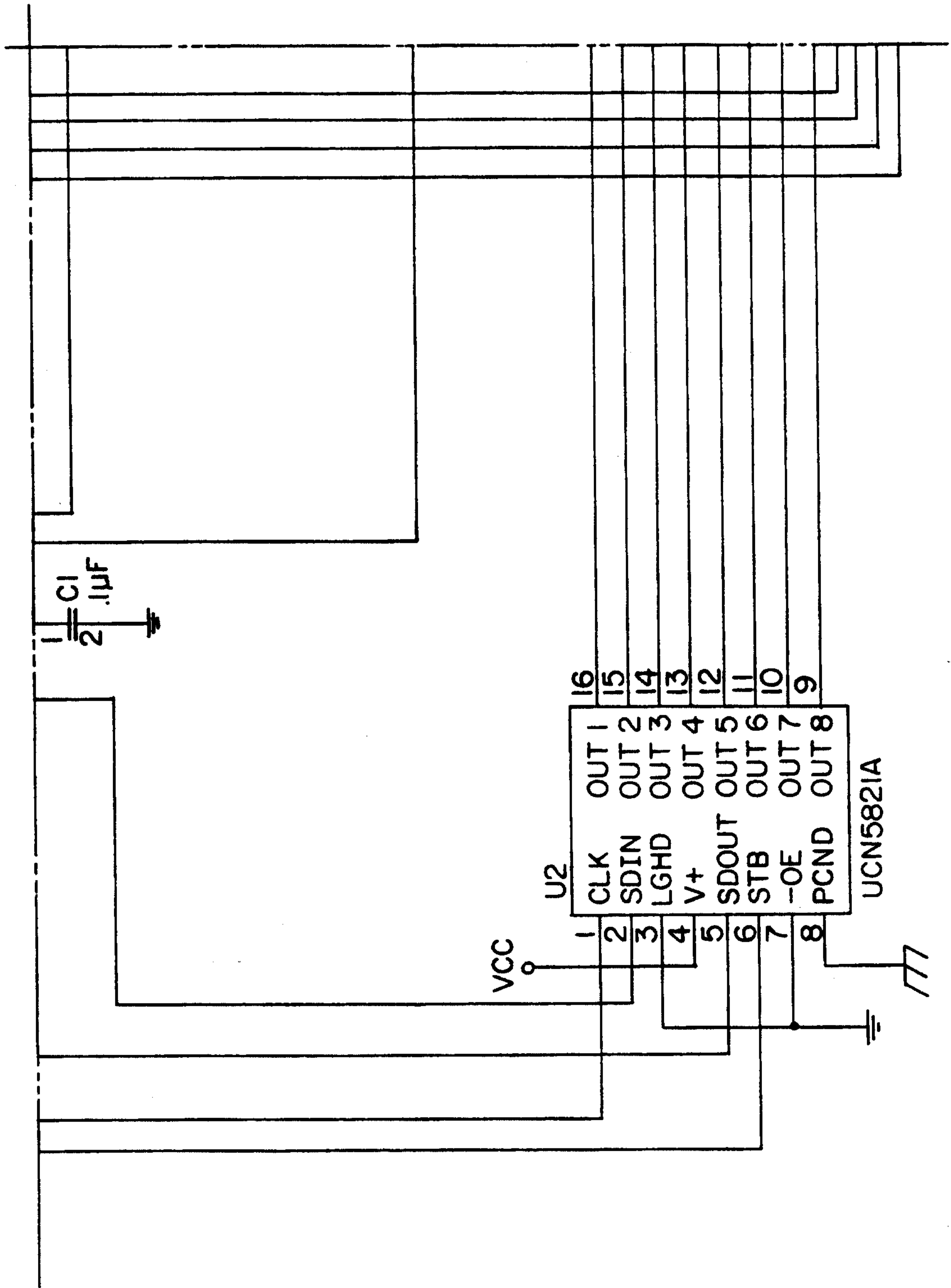

FIG. 18C

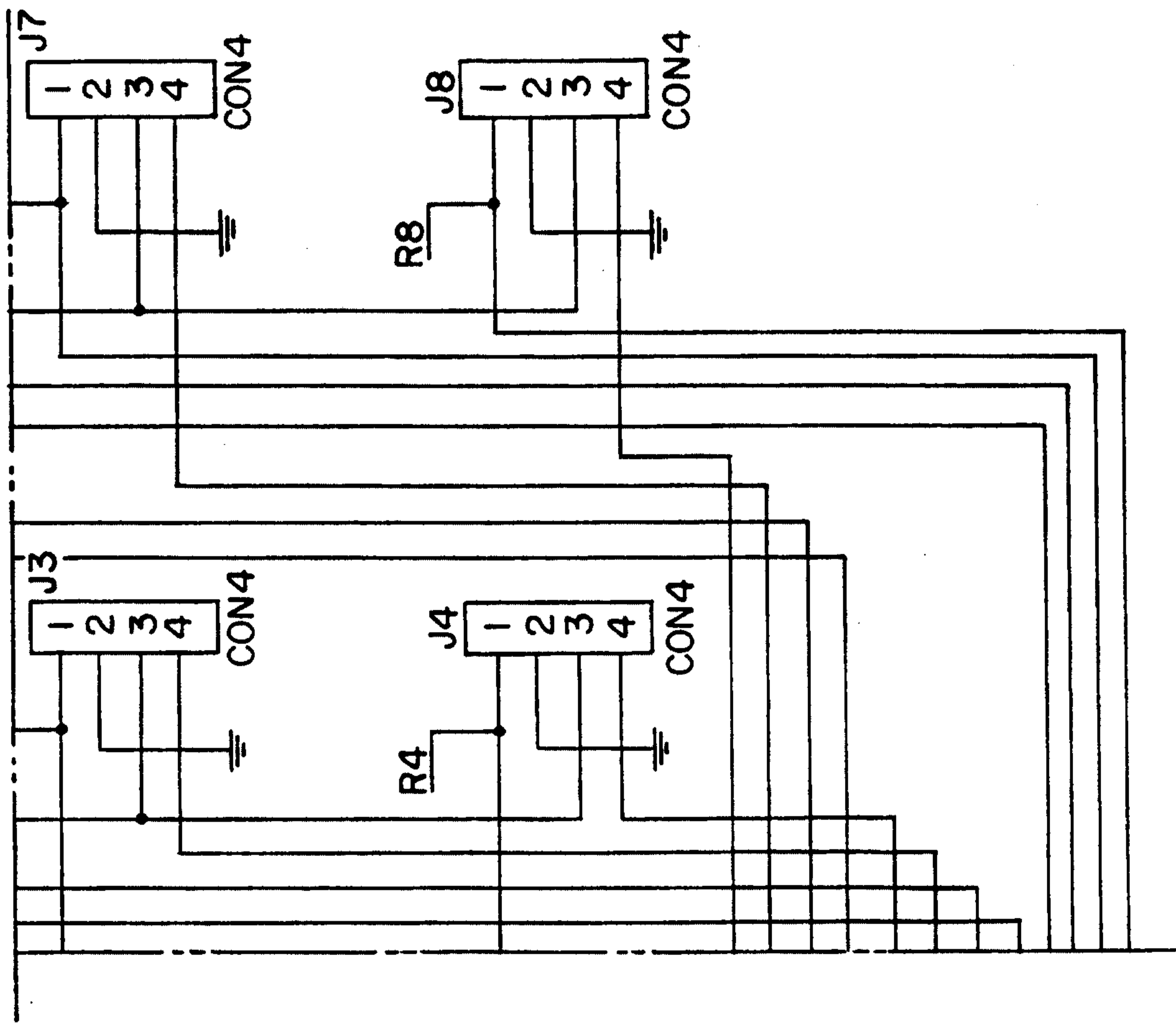

FIG. 18D

