

J. Q. C. SEARLE
Car Heater.

No. 105 260.

Patented July 12, 1870.

Fig. 1.

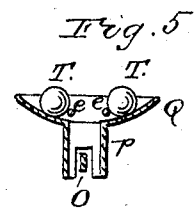
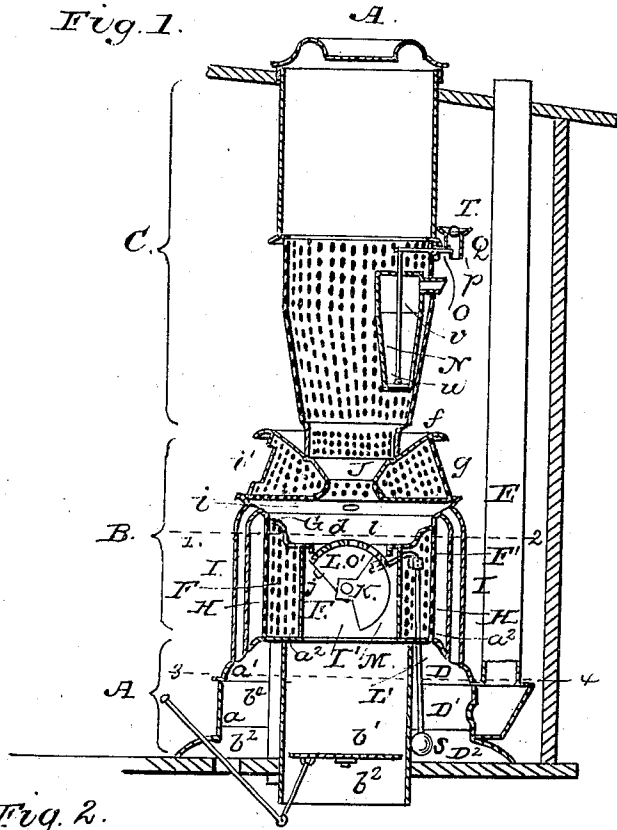

Fig. 2.

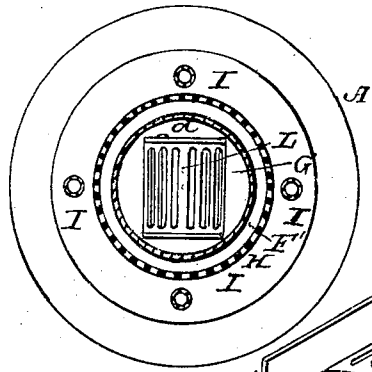

Fig. 3.

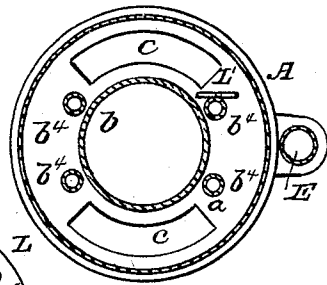
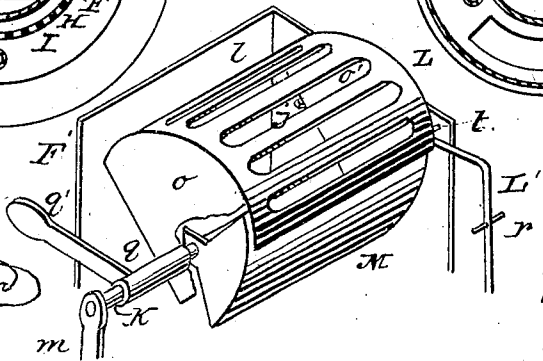

Fig. 4.



Witnesses

C. B. Foster
Albert W. Norris

Inventor

J. Q. C. Searle
By his attorneys
Howson & Son

United States Patent Office.

JOHN Q. C. SEARLE, OF TOPEKA, KANSAS.

Letters Patent No. 105,260, dated July 12, 1870.

IMPROVEMENT IN RAILROAD-CAR STOVES.

The Schedule referred to in these Letters Patent and making part of the same.

I, JOHN Q. C. SEARLE, of Topeka, county of Shawnee, State of Kansas, have invented an Improvement in Stoves, of which the following is a specification.

Object of the Invention.

My invention consists of a stove especially adapted for railway cars and other vehicles, and constructed, as fully described hereafter, so as to be readily supplied with fuel, require little attention, and so that, in case of accident to the vehicle, the contents of the fire-pot will be discharged, and the heated plates will be cooled by a volume of water thrown upon the same.

My invention further consists in perforating the casing of the stove and of the fuel-magazine, as fully described hereafter; of a certain arrangement of the fire-pot, a casing, and external flues; and of a grate of a peculiar construction.

Description of the Accompanying Drawing.

Figure 1 is a sectional elevation of my improved stove and of sufficient of a railway car to illustrate my invention;

Figure 2, a transverse section on the line 1 2, fig. 1;

Figure 3, a transverse section on the line 3 4, fig. 1;

Figure 4, a perspective view, drawn to an enlarged scale, of part of the stove; and

Figure 5, a detached sectional view, drawn to an enlarged scale.

General Description.

A is the base, B the body, and C the magazine or fuel-reservoir of a stove, which is shown as arranged within a railway car, the reservoir extending through the top of the latter, and being provided at its upper end with a detachable cap or cover, A'.

The base of the stove is divided by horizontal partitions $a a'$, and by a central cylindrical tube or casing, b , into annular chambers $D D' D^2$, the chambers $D D'$ communicating with each other through the openings $c c$, fig. 3, in the plate a' , and the chamber D' communicating, at one side, with the main flue or pipe E, which extends through the top of the car.

The cylinder b extends through the bottom of the car, and communicates with a rectangular casing, F, resting on the top plate a^2 of the base, and supporting a shallow fire-pot, G, which has flaring sides and a central rectangular opening, d .

A valve or damper, b' , in the cylinder b , is secured to a rod, b^2 , which extends through the casing of the stove into the car.

A perforated cylindrical casing, H, extends from the fire-pot to the plate a^2 , and incloses the casing F and a surrounding chamber, F', air being admitted to the latter through tubes b^4 , which extend from the plate a^2 , and through the bottom of the car.

With the fire-pot, near the outer edge of the same,

communicate tubes or flues I, which extend downward, outside of the casing F and H, to the base, and communicate with the chamber D.

The casing g of the stove, between the fire-pot and the top f , is inclined, as shown in the drawing, and is perforated, in the present instance, throughout its entire extent; and the fuel-reservoir is likewise perforated from its lower end to a point about midway between the top plate f of the stove and the top of the car.

At the lower end of the reservoir is a "feeder," J, having a perforated expanded or bell-shaped mouth, and from the edge of the latter to the surrounding casing g extends a horizontal perforated plate, h , an opening, i , in the latter, and an opening, i' , in the casing g , each provided with a suitable door, permitting access to the fire-pot.

Through the casings F and H extends a shaft, K, on the outer end of which is a short sleeve, q , the latter being connected at its inner end to a grate, L, consisting of a section, l , of a hollow cylinder, slotted as shown in the drawing, and secured to segmental plates $o o'$, turning on the shaft K, the grate, when in a position to support the fire, extending into the opening d , and bearing against a stop, j , on the casing, F, as shown in fig. 1.

On the segmental plate o' of the grate is a lug, t , beneath which, when the grate is in the position shown in the drawing, extends the bent arm of a lever, L', vibrating on a pin, r , supported on lugs on the casing H, the vertical arm of the lever extending through slots in the partitions $a a'$ into the chamber D^2 , and having at its lower end a ball or weight, s .

The grate is so suspended or weighted that, when the arm of the lever L' is withdrawn from beneath the lug t , the grate will turn in the direction of its arrow, fig. 1, until it strikes a lug, t' , on the casing F.

The sleeve q is provided with a handle, q' , and the shaft K with a handle, m , and to segmental plates attached to the shaft K is connected a plate or damper, M, curved to correspond to the grate L, beneath which it may be turned by revolving the shaft, the damper, when not beneath the grate, resting against the lug t .

Within the magazine C is a water-reservoir, N, having at its lower end an opening, to which is fitted a valve, u , the latter being connected by a wire, v , to a lever which extends through the casing of the reservoir into a slotted tube, p , projecting from a basin, Q, attached to the outer side of the casing.

Across the basin Q, at each side of the tube p , extends a rod, e , which supports a metal ball, T, in the position shown in figs. 1 and 5, for a purpose described hereafter.

Operation.

In burning bituminous or soft coals, which evolve inflammable gases with great rapidity, it is desirable,

in order to effect their perfect combustion, to introduce among them a most abundant supply of air, but without admitting it in such a volume as to cool the gases and cause the production of smoke. This object I have accomplished by perforating the casing of the stove, adjacent to the point where the gases are evolved, to such an extent that the external air can pass almost without resistance to the heated gases, and I have found, by practical tests, that a most thorough admixture of the air with the gases may thus be effected, while the volume of the air is so broken by the numerous minute perforations through which it passes that the sudden reduction of the temperature of the gases which would result from the free admission of the air in any other manner is prevented, a most thorough consumption of the gases within the body of the stove being the result.

In the present instance the air passes through the perforated casing *g* and through the perforated plate *h* into the fire-pot, where it mingles with the products of combustion, and then passes with them downward, through the tubes *I* and chambers *D* and *D'*, to the main flue *E*, air being supplied to the fuel in the grate through the tube *b*.

The direct contact of the heated gases with the exposed flues *I* and with the plates in the base of the stove thoroughly heats these parts and the air which circulates in contact with the same, while the perforated casing *H* is heated by radiation from the flues, and by its contact with the heated fire-pot and casings, and, in turn, imparts its heat to the air which passes through it from the chamber *F'* into the apartment.

The perforations at the lower end of the fuel-reservoir permit the air to pass freely into the reservoir and among the fuel within the same, while the passage of the draught downward through the pipes *I* draws air downward from the reservoir, not only preventing gases from ascending in the latter and passing to the apartment, but also effectually maintaining the coal, even at the mouth of the feeder, at such a low temperature that no gases can be evolved.

By extending the magazine to the roof of the car its capacity is increased so that long journeys may be performed without introducing a new supply of fuel, the constant supervision of the fire, which diverts the attention of the brakemen from more important duties, being thus rendered unnecessary.

Inasmuch as the reservoir is replenished through the top of the car, from suitable reservoirs arranged in the station or adjacent to the track, the cars can be maintained in a more cleanly state than when the fuel is introduced into the stove in the ordinary manner.

The draught may be regulated by turning the shaft *K* so as to carry the damper *M* beneath the grate, and the fire may be sifted by agitating the grate *L* by means of the handle *q*, the ashes being received upon the damper *b'*, which is turned to discharge them when necessary.

Should a violent shock be imparted to the vehicle, or should it be overturned, or even inclined to an unusual degree, the weighted lever *L* will be vibrated so that its end will pass from beneath the lug *t*, when the grate will turn until it strikes the pin *t*, thus leaving a free passage through the casing *F* and tube *b* for the contents of the fire-pot, which, being discharged from the vehicle, cannot set fire to the inflammable portions or injure the passengers.

The shock imparted to, or the unusual inclination of the vehicle, will also cause one or the other of the balls *T* to be dislodged from its place, when it will fall into the tube *p*, and, striking the lever *o*, will operate the latter, raise the valve *u*, and thus cause

the discharge of the water from the reservoir into the heated fire-pot, and upon any heated fuel that may remain within the stove.

When the stove is arranged upon a steamer or other vessel, the tube *b* may extend downward into the water, and affords a ready and cleanly means of removing the contents of the fire-pot at any time.

It will be apparent that other devices may be employed for effecting the discharge of the contents of the reservoir and of the fire-pot. For instance, the reservoir may be partly of glass or other material which will be fractured on the jolting of the vehicle, and the grate may be hinged at one side and supported at the other by a glass rod, which will break when the vehicle is jolted, or fall from its position when inclined.

Slotted plates, slats, or wire-gauze or netting may be substituted for the perforated plates described, and the grate, instead of being cylindrical, may be spherical.

Claims.

1. The combination of a car or other vehicle, a stove, and a fuel-magazine, extending to or through the top of the vehicle, for the purpose described.
 2. The combination of a vehicle, a stove, and a tube, *b*, extending from the fire-pot or ash-pit through the bottom of the vehicle, and so constructed and arranged as to permit the free discharge through the same of the contents of the fire-pot.
 3. A fire-pot arranged above or near the top of a casing, in combination with a fuel-magazine and with a series of external tubes or flues, arranged to conduct the products of combustion from the fire-pot outside of the said casing to the base of the stove.
 4. The combination of a fire-pot, *G*; casing *F*, and outer perforated casing *H*, substantially as and for the purpose described.
 5. The combination, with the said casings *H* and *F*, of tubes *b'*, arranged to admit air to the chamber *F'* between the two casings.
 6. The combination, with a fire-pot and with a flue or flues for conducting the products of combustion downward from the fire-pot, of a plate, *h*, perforated in whole or in part, and arranged above the fire-pot, substantially as described.
 7. A fuel-reservoir, perforated at its lower end, and above its junction with the stove or feeder, substantially as and for the purpose described.
 8. A casing, *g*, consisting of perforated metal, and arranged above the fire-pot of a stove, for the purpose described.
 9. The combination of a stove, a fuel-reservoir, a water-reservoir, and the devices described, or their equivalents, which will cause the discharge of the water on the jolting or tilting of the stove.
 10. The combination of the stove, the dumping-grate, and the devices described, or their equivalents, which, on the jolting or tilting of the stove, will open the grate and discharge the contents of the fire-pot.
 11. The curved grate *L*, arranged and operating substantially as described.
 12. The combination of the curved grate *L* and the curved damper *M*, operating as specified.
 13. The combination of a base-burning stove, a reservoir, and a plate, *h*, supporting the said reservoir.
- In testimony whereof I have signed my name to this specification in the presence of two subscribing witnesses.

J. Q. C. SEARLE.

Witnesses:

CHARLES E. FOSTER,
EDM. F. BROWN.