



INTERNATIONAL APPLICATION PUBLISHED UNDER THE PATENT COOPERATION TREATY (PCT)

<p>(51) International Patent Classification⁶ : A61M 25/01</p>	<p>A1</p>	<p>(11) International Publication Number: WO 99/65558</p> <p>(43) International Publication Date: 23 December 1999 (23.12.99)</p>
<p>(21) International Application Number: PCT/US99/13537</p> <p>(22) International Filing Date: 16 June 1999 (16.06.99)</p> <p>(30) Priority Data: 09/098,443 17 June 1998 (17.06.98) US</p> <p>(71) Applicant: ADVANCED CARDIOVASCULAR SYSTEMS, INC. [US/US]; 3200 Lakeside Drive, Santa Clara, CA 95052-8167 (US).</p> <p>(72) Inventor: JALISI, Marc, M.; Apartment J-6, 30660 Milky Way Drive, Temecula, CA 92592 (US).</p> <p>(74) Agents: CHOW, Y., Ping et al.; Heller Ehrman White & McAuliffe, 525 University Avenue, Palo Alto, CA 94301-1900 (US).</p>	<p>(81) Designated States: AE, AL, AM, AT, AT (Utility model), AU, AZ, BA, BB, BG, BR, BY, CA, CH, CN, CU, CZ, CZ (Utility model), DE, DE (Utility model), DK, DK (Utility model), EE, EE (Utility model), ES, FI, FI (Utility model), GB, GD, GE, GH, GM, HR, HU, ID, IL, IN, IS, JP, KE, KG, KP, KR, KZ, LC, LK, LR, LS, LT, LU, LV, MD, MG, MK, MN, MW, MX, NO, NZ, PL, PT, RO, RU, SD, SE, SG, SI, SK, SK (Utility model), SL, TJ, TM, TR, TT, UA, UG, UZ, VN, YU, ZA, ZW, ARIPO patent (GH, GM, KE, LS, MW, SD, SL, SZ, UG, ZW), Eurasian patent (AM, AZ, BY, KG, KZ, MD, RU, TJ, TM), European patent (AT, BE, CH, CY, DE, DK, ES, FI, FR, GB, GR, IE, IT, LU, MC, NL, PT, SE), OAPI patent (BF, BJ, CF, CG, CI, CM, GA, GN, GW, ML, MR, NE, SN, TD, TG).</p> <p>Published <i>With international search report. Before the expiration of the time limit for amending the claims and to be republished in the event of the receipt of amendments.</i></p>	
<p>(54) Title: COMPOSITE RADIOPAQUE INTRACORPOREAL PRODUCT</p>		
<p>(57) Abstract</p> <p>The invention is directed to a guidewire having a distal flexible member, such as a helical coil, which is formed with at least one highly radiopaque component and at least one high strength component. In a presently preferred embodiment, the highly radiopaque component is at least 10 % and less than about 60 % of the transverse crosssection of the flexible member, preferably at least 20 % but less than 40 %. The highly radiopaque component may be formed of radiopaque material such as platinum, gold, iridium and the like and the high strength component may be formed of a material such as tantalum, stainless steel, NiTi alloys, Co-Cr-Mo alloys and the like.</p>		

FOR THE PURPOSES OF INFORMATION ONLY

Codes used to identify States party to the PCT on the front pages of pamphlets publishing international applications under the PCT.

AL	Albania	ES	Spain	LS	Lesotho	SI	Slovenia
AM	Armenia	FI	Finland	LT	Lithuania	SK	Slovakia
AT	Austria	FR	France	LU	Luxembourg	SN	Senegal
AU	Australia	GA	Gabon	LV	Latvia	SZ	Swaziland
AZ	Azerbaijan	GB	United Kingdom	MC	Monaco	TD	Chad
BA	Bosnia and Herzegovina	GE	Georgia	MD	Republic of Moldova	TG	Togo
BB	Barbados	GH	Ghana	MG	Madagascar	TJ	Tajikistan
BE	Belgium	GN	Guinea	MK	The former Yugoslav Republic of Macedonia	TM	Turkmenistan
BF	Burkina Faso	GR	Greece	ML	Mali	TR	Turkey
BG	Bulgaria	HU	Hungary	MN	Mongolia	TT	Trinidad and Tobago
BJ	Benin	IE	Ireland	MR	Mauritania	UA	Ukraine
BR	Brazil	IL	Israel	MW	Malawi	UG	Uganda
BY	Belarus	IS	Iceland	MX	Mexico	US	United States of America
CA	Canada	IT	Italy	NE	Niger	UZ	Uzbekistan
CF	Central African Republic	JP	Japan	NL	Netherlands	VN	Viet Nam
CG	Congo	KE	Kenya	NO	Norway	YU	Yugoslavia
CH	Switzerland	KG	Kyrgyzstan	NZ	New Zealand	ZW	Zimbabwe
CI	Côte d'Ivoire	KP	Democratic People's Republic of Korea	PL	Poland		
CM	Cameroon	KR	Republic of Korea	PT	Portugal		
CN	China	KZ	Kazakstan	RO	Romania		
CU	Cuba	LC	Saint Lucia	RU	Russian Federation		
CZ	Czech Republic	LI	Liechtenstein	SD	Sudan		
DE	Germany	LK	Sri Lanka	SE	Sweden		
DK	Denmark	LR	Liberia	SG	Singapore		
EE	Estonia						

COMPOSITE RADIOPAQUE INTRACORPOREAL PRODUCT

BACKGROUND OF THE INVENTION

This invention relates to the field of intracorporeal medical devices such as guidewires for advancing intraluminal devices including stent delivery catheters, balloon dilatation catheters, atherectomy catheters and other
5 intraluminal devices within a patient's body lumen.

Conventional guidewires for angioplasty, stent delivery, atherectomy and other vascular procedures usually comprise an elongated core member with one or more tapered sections near the distal end thereof and a flexible body such as
10 a helical coil or a tubular body of polymeric material disposed about the distal portion of the core member. The flexible body may extend proximally to an intermediate portion of the guidewire. A shapable member, which may be the distal extremity of the core member or a separate shaping ribbon which is secured to the distal extremity of the core member extends through the flexible
15 body and is secured to the distal end of the flexible body by soldering, brazing or welding which forms a rounded distal tip. Torquing means are provided on the proximal end of the core member to rotate, and thereby steer, the guidewire while it is being advanced through a patient's vascular system.

Further details of guidewires, and devices associated therewith for
20 various interventional procedures can be found in U.S. Patent 4,748,986 (Morrison et al.); U.S. Patent 4,538,622 (Samson et al.); U.S. Patent 5,135,503 (Abrams); U.S. Patent 5,341,818 (Abrams et al.); and U.S. Patent 5,345,945 (Hodgson, et al.) which are hereby incorporated herein in their entirety by reference thereto.

25 In a typical coronary procedure using a guidewire, a guiding catheter having a preformed distal tip is percutaneously introduced into a patient's peripheral artery, e.g. femoral or brachial artery, by means of a conventional Seldinger technique and advanced and steered therein until the distal tip of the guiding catheter is seated in the ostium of a desired coronary artery.

30 There are two basic techniques for advancing a guidewire into the desired location within a patient's coronary anatomy through the in-place guiding catheter. The first is a preload technique which is used primarily for

over-the-wire (OTW) catheters and the second is the bare wire technique which is used primarily for rail type catheters.

With the preload technique, a guidewire is positioned within an inner lumen of an OTW device such as a dilatation catheter or stent delivery catheter with the distal tip of the guidewire just proximal to the distal tip of the catheter and then both are advanced through the guiding catheter to the distal end thereof. The guidewire is first advanced out of the distal end of the guiding catheter into the patient's coronary vasculature until the distal end of the guidewire crosses the arterial location where the interventional procedure is to be performed, e.g. a lesion to be dilated or an arterial region where a stent is to be deployed. The catheter, which is slidably mounted onto the guidewire, is advanced out of the guiding catheter into the patient's coronary anatomy over the previously introduced guidewire until the operative portion of the intravascular device, e.g. the balloon of a dilatation or a stent delivery catheter, is properly positioned across the arterial location. Once the catheter is in position with the operative means located within the desired arterial location, the interventional procedure is performed. The catheter can then be removed from the patient over the guidewire. Usually, the guidewire is left in place for a period of time after the dilatation or stent delivery procedure is completed to ensure reaccess to the distal arterial location if it is necessary. For example, in the event of arterial blockage due to dissected lining collapse, a rapid exchange type perfusion balloon catheter such as described and claimed in U.S. Patent 5,516,336 (McInnes et al), can be advanced over the in-place guidewire so that the balloon can be inflated to open up the arterial passageway and allow blood to perfuse through the distal section of the catheter to a distal location until the dissection is reattached to the arterial wall by natural healing.

With the bare wire technique, the guidewire is first advanced by itself through the guiding catheter until the distal tip of the guidewire extends beyond the arterial location where the procedure is to be performed. Then a rail type catheter, such as described in U.S. Patent No. 5,061,395 (Yock) and the previously discussed McInnes et al. patent, which are incorporated herein by reference, is mounted onto the proximal portion of the guidewire which extends

out of the proximal end of the guiding catheter and which is outside of the patient. The catheter is advanced over the guidewire, while the position of the guidewire is fixed, until the operative means on the rail type catheter is disposed within the arterial location where the procedure is to be performed. After the
5 procedure the intravascular device may be withdrawn from the patient over the guidewire or the guidewire advanced further within the coronary anatomy for an additional procedure.

An important attribute for guidewires is having sufficient radiopacity to be visualized under a fluoroscope, allowing the surgeon to advance the guidewire
10 to a desired intraluminal location, particularly the distal extremity of the guidewire. Unfortunately, the most suitable materials for guidewires, such as stainless steel and NiTi alloys, exhibit relatively low radiopacity. Accordingly, various strategies have been employed to overcome this deficiency. Portions of the guidewire, usually the shapeable distal tip, are typically made from or coated
15 with highly radiopaque metals such as platinum, iridium, gold or alloys thereof. For example, a 3 to 30 cm platinum tip coil is frequently soldered to the distal extremity of the guidewire. An obvious drawback of these prior art methods is the high expense and scarcity of highly radiopaque metals and the difficulty and expense of manufacturing products from these materials. The requirement of
20 both a high degree of radiopacity, high strength and flexibility can present design problems.

Accordingly, there remains a need for guidewires having sufficient radiopacity to allow visualization under a fluoroscope without the extensive use of expensive radiopaque metals such as platinum, gold, iridium and the like.
25

SUMMARY OF THE INVENTION

The present invention is directed to an intracorporeal device such as a guidewire having an elongate core member with a proximal core section and a distal core section and a flexible body such as a helical coil formed of metallic
30 wire which is disposed about and secured to at least a portion of the distal core section.

In accordance with the invention, the intracorporeal product has a body with multi-components, at least one highly radiopaque component and at least one high strength component having less radiopacity than the highly radiopaque component. The amount of the highly radiopaque component and the high strength component of the flexible body depends upon the radiopacity of each of the components. Generally, however, the highly radiopaque component should be at least about 10% but not be more than about 60%, preferably about 20% to about 40%, of the total transverse cross-section of the flexible body. The greater radiopacity the high strength component has, lessens the amount of the expensive highly radiopaque material which is needed.

The highly radiopaque material of the coil may be selected from the group of platinum, gold, iridium, highly radiopaque alloys thereof. The presently preferred highly radiopaque material is an alloy of 90%(wt) Pt and 10%(wt.) Ir. The high strength material of the coil may be selected from the groups consisting of radiopaque materials such as tantalum, tungsten and silver and non-radiopaque materials such as stainless steel, NiTi alloys and Co-Cr-Mo alloys. Tantalum and alloys thereof are preferred because these materials have significant radiopacity in addition to being high strength and can more significantly reduce the amount of expensive radiopaque material which much be used for a particular degree of radiopacity. For example, a solid wire of 90% platinum -10% iridium will provide complete radiopacity, whereas, a wire of the same thickness with 70% tantalum core and 30% of a 90% Pt - 10% Ir alloy cladding will provided the same degree of radiopacity but substantially improved mechanical properties. The use of non-radiopaque high strength metals will provide a fair radiopacity with adequate or improved mechanical properties depending upon the material used. A thickness of about 5 to about 10 micrometers of highly radiopaque material will usually provide complete radiopacity for intracorporeal use with conventional fluoroscopic observation.

The presently preferred form of the flexible body which is secured to the distal core section is a two component metallic wire member such as a helical coil. Other forms include a multi-wire braid formed of two-component metallic wires. In one presently preferred embodiment, the two-component wire is made

of a highly radiopaque cladding and a relatively high strength material. In this way, the radiopaque material of the cladding can be chosen for its radiopaque properties and the core material can be chosen for strength properties that enhance the guidewire's performance. Alternatively, the core material may be highly radiopaque and the cladding may be formed of the high strength material.

The distal end of the helical coil may be attached directly or indirectly to the distal end of the core member and it may also be secured to the core member at one or more proximal locations.

In order to increase the flexibility of the distal section of the guidewire, the core member of the guidewire may be formed in a conventional manner with a distal section having at least one tapered segment, wherein the elongate core member tapers distally to reduced transverse dimensions. If desired, the one or more distally tapered segments of the distal section of the elongate core member may be marked with radiopaque markers to indicate where a tapered segment begins or ends. In this way, a physician using the guidewire is able to identify the relative flexibility and stiffness of an area of interest on the guidewire using fluoroscopic imaging.

A second or proximal coil formed of helically shaped wire may be provided proximal to the radiopaque first coil which is formed of less radiopaque material. The wire forming the second coil may have a circular transverse cross-section or a substantially rectangular cross section. A coil of wire having a rectangular cross section provides increased stiffness and coil integrity as compared to wire with a round cross section of similar thickness, due to the increased cross sectional area. The proximal end of the second coil is attached to the distal section of the elongate core member by means of adhesive, solder and the like. The distal end of the second coil is preferably secured to the distal section of the core member by the same mass of solder or the like that secures the proximal end of the first, highly radiopaque coil to the core member.

The flexible body of the present invention has at least adequate radiopacity and strength while being substantially cheaper to make than similar structures with helical coils formed of precious metal such as platinum and gold.

By appropriately choosing the materials, properties can be obtained which are better than conventional products, while significantly reducing costs.

These and other advantages of the invention will become more apparent from the following detailed description of the invention when taken in
5 conjunction with the accompanying exemplary drawings.

BRIEF DESCRIPTION OF THE DRAWINGS

FIG. 1 is a schematic elevational view, partially in section, of a guidewire which embodies features of the invention.

FIG. 2 is a transverse cross-sectional view of the guidewire shown in Fig.
10 1 taken along the lines 2-2.

Fig. 3 is an enlarged longitudinal cross-sectional view of the guidewire shown in Fig. 1 within the circle 3.

Fig. 4 is an elevational view partially in section of an alternative guidewire wherein the distal tip of the core member is flatten and extends and is secured
15 to the distal end of the coil.

FIG. 5 is a transverse cross-sectional view of the guidewire shown in Fig. 4 taken along the lines 5-5.

Fig. 6 is a longitudinal cross-sectional view of an alternative guidewire design which has a proximal coil with a rectangular transverse cross-section.
20

DETAILED DESCRIPTION OF THE INVENTION

FIGS. 1- 3 illustrate a guidewire 10 having features of this invention that generally include an elongated core member 11, with a proximal core section 12 and a distal core section 13 and a distal, highly radiopaque helical coil 14
25 disposed about and secured to the distal extremity of the core member. A shaping ribbon 15 extends from the distal end of the core member 11 and is secured to the mass of solder or weldment forming the rounded distal tip 16 of the guidewire. The proximal end of the shaping ribbon 15 is secured to the distal end of the core member 11 by suitable means such as solder, brazement,
30 weldment or adhesive. The proximal end of the distal highly radiopaque coil 14 is secured to the core member 11 by mass 17 which may be solder, brazement,

weldment or adhesive. A second or proximal coil 18 is secured by its distal end to the core member by the same mass that secures the proximal end of the distal highly radiopaque coil 14 to the core member 11. The proximal end of the proximal coil 18 is secure to the core member by solder, brazement, weldment
5 or adhesive 20. The proximal end of the distal coil 14 and the distal end of the proximal coil 18 are preferably threaded together at the site 17 of securing these ends to the core member 11.

The core member 11 of the guidewire 10, as shown in Fig. 1, generally may have conventional features with conventional dimensions. The proximal
10 core section has a relatively constant or uniform transverse cross-sectional dimensions and the distal core section 13 has a first taper 21, a second taper 22 and a third taper 23 which taper in the distal direction to smaller transverse cross-sectional dimensions. An first intermediate uniform dimensioned core portion 24 extends between the first and second tapers 21 and 22 and
15 a second intermediate uniform dimensioned core portion 25 extends between the second taper 22 and the third taper 23.

As shown in more detail in Fig. 3, the distal highly radiopaque coil 14 has an inner portion 26 and an exterior portion 27. The inner portion or core 26 of coil 14 is formed of high strength metallic material such as stainless steel, NiTi
20 alloy, Co-Cr-Mo alloys such as Elgiloy or MP35N and tantalum (or alloys thereof). Tantalum is presently preferred because it also has a high degree of radiopacity in addition to high strength. The exterior portion or cladding 27 is formed of a highly radiopaque metallic material such as platinum, gold, iridium, palladium, tantalum, tungsten, silver and highly radiopaque alloys thereof. If
25 desired these components forming the wire of coil 14 may be reversed, i.e. the inner portion 26 may be highly radiopaque and the cladding 27 may be formed of high strength material

Fig. 4 illustrates a guidewire 30 which has various alternative embodiments. The first alternative embodiment is the core member 31 having a
30 flattened distal extremity 32 (instead of a shaping ribbon) which extends and is secured to the rounded mass 33 of solder, brazement, weldment or adhesive which is secures the distal end of the distal, highly radiopaque coil 34 thereto.

The proximal helical coil 35 may be formed of conventional stainless steel wire. As in the embodiment shown in Figs. 1 and 3 the distal end of the second proximal coil 35 is secured to the core member 31 at the same location 36 as the proximal end of the distal, highly radiopaque coil 34. The distal, highly radiopaque coil 34, as shown in Fig. 5 is formed of an inner component 37 of highly radiopaque material and an outer component 38 of high strength material.

Another alternative design is depicted in Fig. 6. In this design, the guidewire 40 has a core member 41 with a flattened distal extremity 42 as in the embodiment shown in Fig. 4. While not shown in detail the distal coil 43 has a highly radiopaque cladding and a high strength core as described for the embodiment of Figs. 1-3. However, the proximal coil 44 disposed about the core member 41 has an essentially rectangular shaped transverse cross-section as compared to the circular transverse cross-section of the distal coil 43. The rectangular transverse cross-section provides additional support. This guidewire design is primarily for peripheral arteries and generally has larger dimensions than the embodiments shown in Figs. 1-5.

The clad wire forming the distal coil may be formed in a variety of ways. The presently preferred manner is to prepare a tubular member of one of the components and a solid core (e.g. wire or rod) of the other component suitably sized so that the tubular member formed of one component can be co-drawn with the solid core of the other component to flow with the latter to form a strong bond. It is presently preferred to form the tubular member of the highly radiopaque material and the core member of the high strength material with a lesser radiopacity. Other means for forming the clad wire for the distal coil include plasma spraying one component onto a wire or rod of the other component. Physical vapor deposition may also be employed in a similar manner. Electroplating and other more conventional methods may be used to form the clad product.

Generally, the overall length of the guidewire may range from about 80 to about 320 cm, preferably about 160 to about 200 for coronary use. Typically, commercial guidewire products of the invention will come in standard lengths of 175, 190 and 300 cm. The distal section of the guidewire is about 1 to about 10

cm, preferably about 2 to about 5 cm in length, the intermediate section is about 15 to about 50, preferably about 25 to about 40 cm in length. The outer diameter of the guidewire may vary depending upon use, but typically is about 0.008 to about 0.035 inch (0.2-0.9 mm). The lengths and diameters of the
5 tapers may likewise vary. The composite wire forming the proximal and distal coils will typically have a diameter of about 0.002 to about 0.006 inch (0.051-0.15 mm). A 0.002 inch diameter composite wire is typically used for forming a coil of about 0.010 to about 0.014 inch (0.25-0.36 mm) in diameter, a 0.0025 inch (0.063 mm) wire for a coil with an OD of 0.0014 inch and a wire of 0.0055
10 inch (0.14 mm) for larger OD coils. To the extent not otherwise described herein, the dimensions, constructions and materials of the guidewire may be conventional.

Although individual features of embodiments of the invention may be shown in some of the drawings and not in others, those skilled in the art will
15 recognize that individual features of one embodiment of the invention can be combined with any or all the features of another embodiment. Various modification may be made to the invention without departing from the scope thereof.

WHAT IS CLAIMED IS:

1. A guidewire for intraluminal advancement of a medical device within a patient, comprising:

- 5 a) an elongated core member which has a proximal core section and a distal core section; and
- b) a flexible body which is disposed about and secured to a portion of the distal core section and which is formed of a highly radiopaque component and a high strength component.

10 2. The guidewire of claim 1 wherein the flexible body is a helical coil formed of wire.

3. The guidewire of claim 2 wherein the wire forming the helical wire has a highly radiopaque exterior and a high strength interior.

15

4. The guidewire of claim 2 wherein the wire forming the helical wire has a highly radiopaque interior and a high strength exterior.

5. The guidewire of claim 1 wherein the highly radiopaque component is selected from the group consisting of platinum, iridium, gold,
20 palladium, tantalum, tungsten, silver and radiopaque alloys thereof.

6. The guidewire of claim 1 wherein the high strength component is selected from the group consisting of stainless steel, NiTi alloys, Co-Cr-Mo alloys, tantalum and tantalum alloys.

25

7. A guidewire for intraluminal advancement of a medical device within a patient, comprising:

- a) an elongated core member which has a proximal core section and a distal core section having at least one taper in the distal
30 directed;

b) a first helical coil which is disposed about and secured to a portion of the distal core section and which is formed of a highly radiopaque component and a high strength component; and

5 c) a second helical coil which is disposed about and secured to a portion of the distal core section and which is disposed proximal to the first helical coil.

8. The guidewire of claim 7 wherein a proximal extremity of the first helical coil and a distal extremity of the second coil are secured to the core member at a first location.

10

9. The guidewire of claim 7 wherein the core member has a flattened distal tip.

10. The guidewire of claim 9 wherein a distal end of the first helical coil is secured to the flattened distal tip of the core member.

15

11. The guidewire of claim 7 wherein a flattened ribbon having proximal and distal ends is secured by its distal end to the distal end of the first helical coil.

20

12. The guidewire of claim 11 wherein the flattened ribbon is secured by its proximal end to the distal end of the core member.

13. A flexible body for an intracorporeal device comprising a helically shaped wire formed of a highly radiopaque component and a high strength component.

25

14. The flexible body of claim 13 wherein the highly radiopaque component is a cladding and the high strength component is a core.

15. The flexible body of claim 13 wherein the highly radiopaque component is a core and the high strength component is a cladding.

30

16. The flexible body of claim 16 wherein the highly radiopaque component comprises at least 10% but not more than 60% of the transverse cross-section of the flexible body.

5 17. The flexible body of claim 16 wherein the highly radiopaque component comprises at least 20% but not more than 40% of the transverse cross-section of the flexible body.

10 18. A radiopaque body for intracorporeal use comprising a first layer formed of a highly radiopaque component selected from the group consisting of platinum, iridium and alloys thereof and a second layer formed of a high strength component selected from the group consisting of tantalum, tungsten and alloys thereof.

15 19. The radiopaque body of claim 18 wherein the highly radiopaque layer is formed of an alloy of platinum and iridium.

20. The radiopaque body of claim 19 wherein the high strength layer is formed of tantalum.

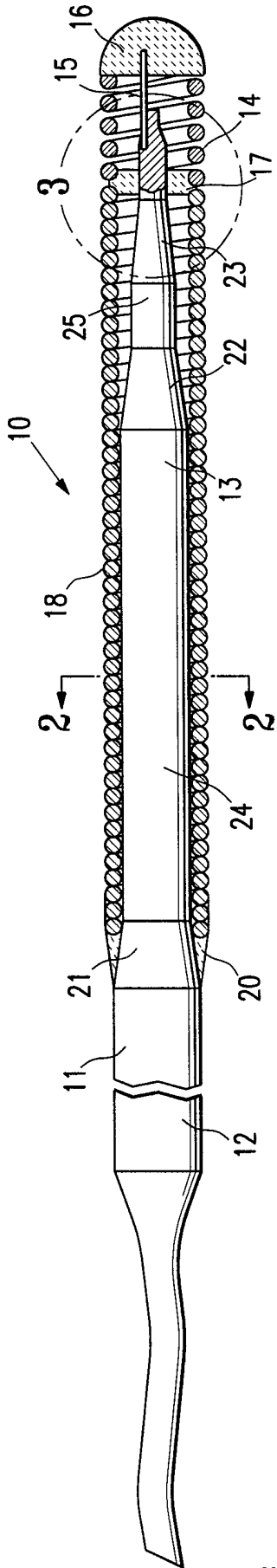

FIG. 1

1/2

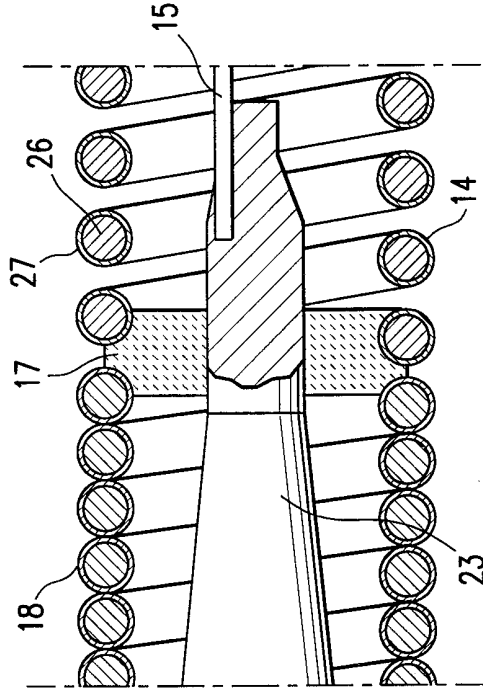

FIG. 3

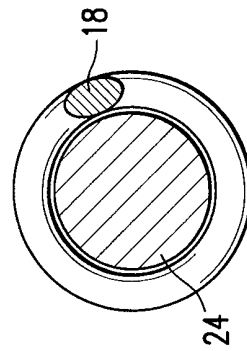

FIG. 2

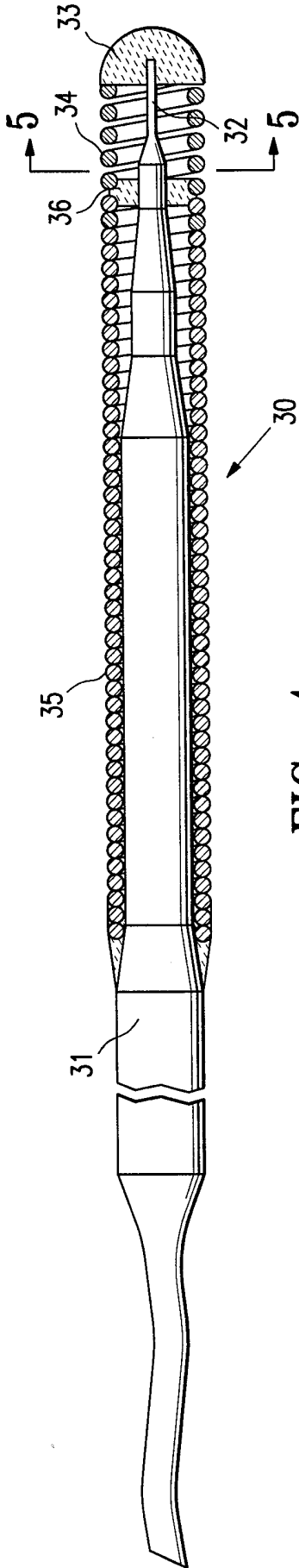

FIG. 4

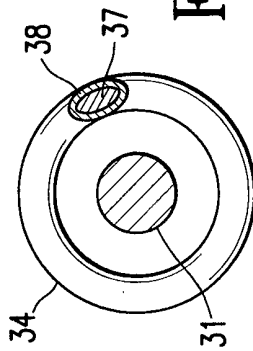

FIG. 5

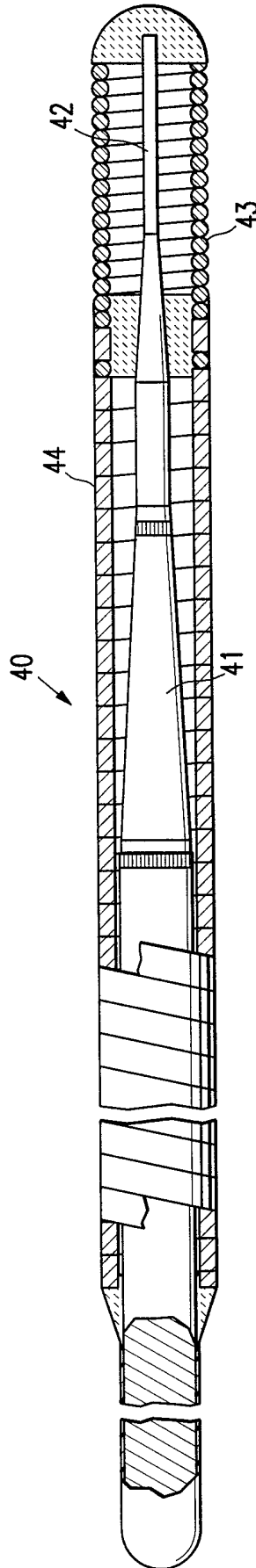

FIG. 6

INTERNATIONAL SEARCH REPORT

International Application No

PCT/JP 99/13537

A. CLASSIFICATION OF SUBJECT MATTER
IPC 6 A61M25/01

According to International Patent Classification (IPC) or to both national classification and IPC

B. FIELDS SEARCHED

Minimum documentation searched (classification system followed by classification symbols)
IPC 6 A61M

Documentation searched other than minimum documentation to the extent that such documents are included in the fields searched

Electronic data base consulted during the international search (name of data base and, where practical, search terms used)

C. DOCUMENTS CONSIDERED TO BE RELEVANT

Category *	Citation of document, with indication, where appropriate, of the relevant passages	Relevant to claim No.
X	US 5 144 959 A (GAMBALE RICHARD A ET AL) 8 September 1992 (1992-09-08) column 3, line 46 -column 4, line 26; figures ---	1-3, 5-14,16
X	US 5 647 127 A (MIYATA NAOHIKO ET AL) 15 July 1997 (1997-07-15) column 5, line 26 - line 43; figure 7 ---	1,2,4-7, 9,13,15
X	WO 97 00705 A (MICROSPRING CO INC ;DOBSON PAUL J (US)) 9 January 1997 (1997-01-09) the whole document -----	1-3,5-7, 9,10,13, 16,17

Further documents are listed in the continuation of box C.

Patent family members are listed in annex.

* Special categories of cited documents :

- *A* document defining the general state of the art which is not considered to be of particular relevance
- *E* earlier document but published on or after the international filing date
- *L* document which may throw doubts on priority claim(s) or which is cited to establish the publication date of another citation or other special reason (as specified)
- *O* document referring to an oral disclosure, use, exhibition or other means
- *P* document published prior to the international filing date but later than the priority date claimed

- *T* later document published after the international filing date or priority date and not in conflict with the application but cited to understand the principle or theory underlying the invention
- *X* document of particular relevance; the claimed invention cannot be considered novel or cannot be considered to involve an inventive step when the document is taken alone
- *Y* document of particular relevance; the claimed invention cannot be considered to involve an inventive step when the document is combined with one or more other such documents, such combination being obvious to a person skilled in the art.
- *Z* document member of the same patent family

Date of the actual completion of the international search

30 August 1999

Date of mailing of the international search report

12.11.1999

Name and mailing address of the ISA

European Patent Office, P.B. 5818 Patentlaan 2
NL - 2280 HV Rijswijk
Tel. (+31-70) 340-2040, Tx. 31 651 epo nl,
Fax: (+31-70) 340-3016

Authorized officer

KOUSOURETAS, I

INTERNATIONAL SEARCH REPORT

Information on patent family members

International Application No

PCT, JS 99/13537

Patent document cited in search report	Publication date	Patent family member(s)	Publication date
US 5144959 A	08-09-1992	JP 2902076 B JP 3133463 A	07-06-1999 06-06-1991
US 5647127 A	15-07-1997	US 5520194 A EP 0666086 A	28-05-1996 09-08-1995
WO 9700705 A	09-01-1997	US 5724989 A EP 0833677 A US 5876783 A	10-03-1998 08-04-1998 02-03-1999

INTERNATIONAL SEARCH REPORT

International application No.

PCT/US 99/ 13537

Box I Observations where certain claims were found unsearchable (Continuation of item 1 of first sheet)

This International Search Report has not been established in respect of certain claims under Article 17(2)(a) for the following reasons:

1. Claims Nos.:
because they relate to subject matter not required to be searched by this Authority, namely:

2. Claims Nos.:
because they relate to parts of the International Application that do not comply with the prescribed requirements to such an extent that no meaningful International Search can be carried out, specifically:

3. Claims Nos.:
because they are dependent claims and are not drafted in accordance with the second and third sentences of Rule 6.4(a).

Box II Observations where unity of invention is lacking (Continuation of item 2 of first sheet)

This International Searching Authority found multiple inventions in this international application, as follows:

see additional sheet

1. As all required additional search fees were timely paid by the applicant, this International Search Report covers all searchable claims.
2. As all searchable claims could be searched without effort justifying an additional fee, this Authority did not invite payment of any additional fee.
3. As only some of the required additional search fees were timely paid by the applicant, this International Search Report covers only those claims for which fees were paid, specifically claims Nos.:
4. No required additional search fees were timely paid by the applicant. Consequently, this International Search Report is restricted to the invention first mentioned in the claims; it is covered by claims Nos.:

1-17

Remark on Protest

The additional search fees were accompanied by the applicant's protest.

No protest accompanied the payment of additional search fees.

FURTHER INFORMATION CONTINUED FROM PCT/ISA/ 210

1.- Claims 1-17:

1.1- Claims 1-12:

A guidewire comprising a flexible body formed of a highly radiopaque component and a highly strength component and an elongated core member.

1.2- Claims 13-17:

A flexible body formed of a highly radiopaque component and a high strength component and comprising a helically shaped wire.

2.- Claims 18-20:

A radiopaque body comprising a first layer formed of a highly radiopaque component and a second layer formed of a high strength component, wherein the radiopaque component is selected from the group consisting of platinum, iridium and alloys thereof and the high strength component is selected from the group consisting of tantalum, tungstem and alloys thereof.