

(No Model.)

2 Sheets—Sheet 1.

A. WESTMAN.
HAY LOADER.

No. 548,491.

Patented Oct. 22, 1895.

Fig: 1.

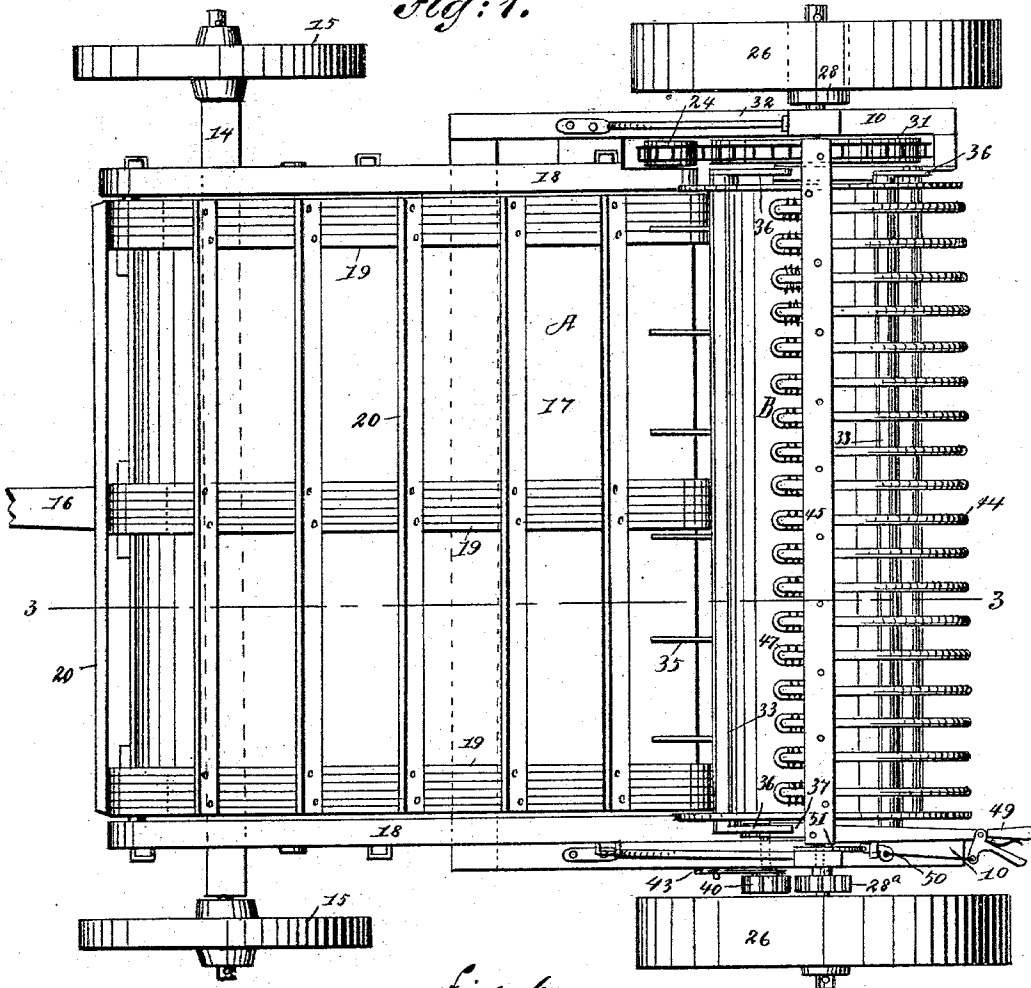

Fig: 4.

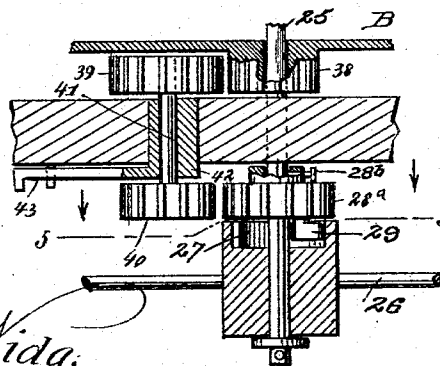

Fig: 6.

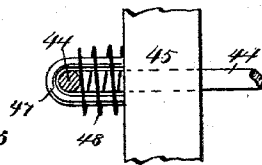
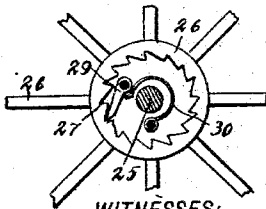

Fig: 5.



WITNESSES:

Chas. Nida.
Ed. Allen

INVENTOR

A. Westman.

BY *Munn & Co*

ATTORNEYS.

(No Model.)

2 Sheets—Sheet 2.

A. WESTMAN. HAY LOADER.

No. 548,491.

Patented Oct. 22, 1895.

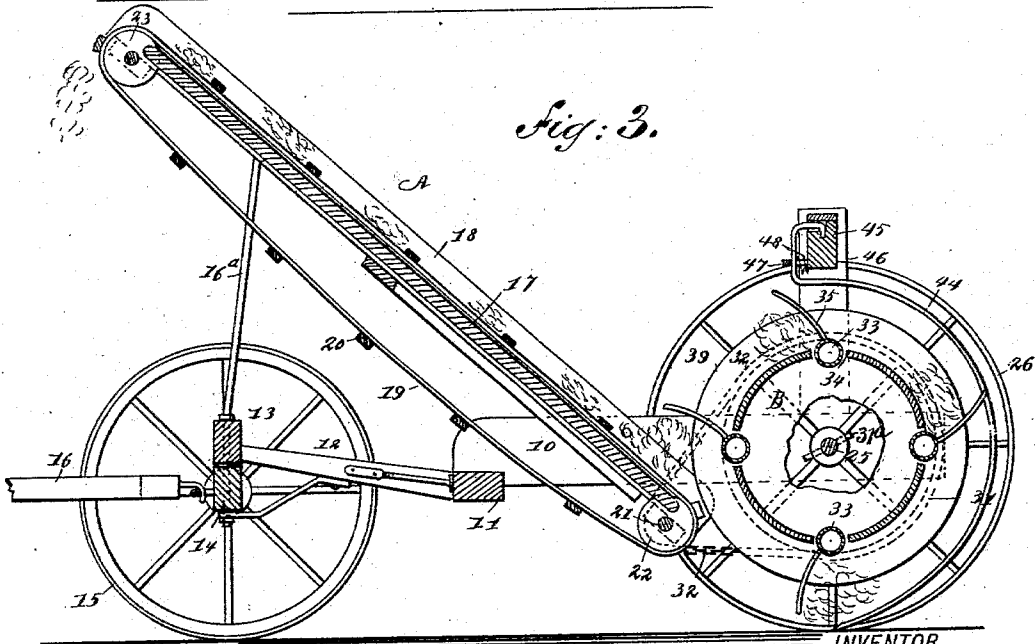
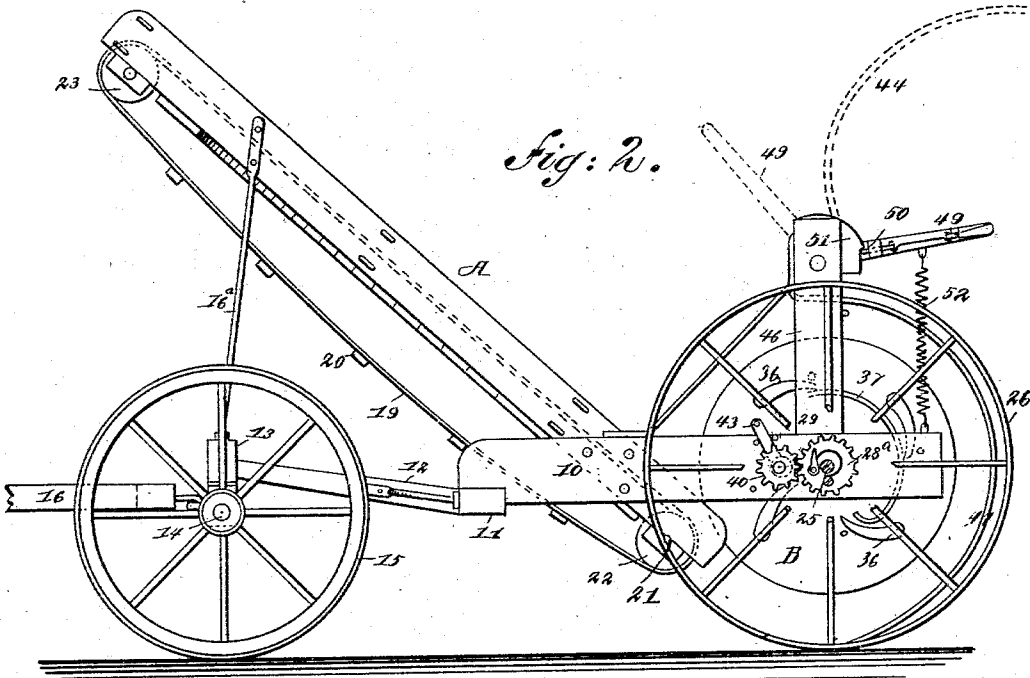

WITNESSES:

*Chas. Nida.
Fred. A. ten*

INVENTOR

A. Westman.

BY *Munn & Co*

ATTORNEYS.

UNITED STATES PATENT OFFICE.

AUGUST WESTMAN, OF TRACY, MINNESOTA.

HAY-LOADER.

SPECIFICATION forming part of Letters Patent No. 548,491, dated October 22, 1895.

Application filed September 1, 1894. Serial No. 521,903. (No model.)

To all whom it may concern:

Be it known that I, AUGUST WESTMAN, of Tracy, in the county of Lyon and State of Minnesota, have invented a new and Improved Hay-Loader, of which the following is a full, clear, and exact description.

The invention relates to an improved hay-loader of that class wherein a revolving finger-cylinder is employed in connection with a carrier, whereby the hay gathered by the cylinder is elevated to the wagon above the carrier; and the object of the invention is to improve the construction of the finger-cylinder whereby the same will be made more effective in operation and more simple and durable in construction.

To this end the invention consists in certain peculiar features of construction and combinations, as will be fully described hereinafter, and finally embodied in the claim.

The invention consists in the novel construction and combination of the several parts, as will be hereinafter fully set forth, and pointed out in the claim.

Reference is to be had to the accompanying drawings, forming a part of this specification, in which similar figures and letters of reference indicate corresponding parts in all the views.

Figure 1 is a plan view of the loader. Fig. 2 is a side elevation thereof. Fig. 3 is a section taken vertically on the line 3 3 of Fig. 1. Fig. 4 is a detail view of a gearing employed to rotate the cylinder and communicate motion to the carrier. Fig. 5 is a detail view of the ratchet mechanism used for connection with the ground-wheels, and Fig. 6 is a detail view of the rake-head, illustrating the manner in which the rake-teeth are attached to the head.

In carrying out the invention the frame of the loader may be said to consist of two horizontal side beams 10, connected at the front by a cross-bar 11, to which cross-bar a reach 12 is secured, carrying a bolster 13 to which the forward axle 14 is pivoted, the said forward axle being provided with ground-wheels 15, adapted to track the wagon with which the loader is to be connected, the loader having attached to its forward axle a tongue 16, whereby it may be readily attached to the wagon

with comparatively little exertion on the part of the operator.

A carrier or elevator A is secured at or near its lower end in the side beams 10 of the frame, as is best shown in Fig. 2; and the said carrier or elevator has an upward and forward inclination, being supported at its upper end by braces 16^a, attached, preferably, to the bolster 13. The elevator consists, primarily, of a flooring 17, contained between two side bars or beams 18 and endless belts 19, which pass over both sides of the flooring, extending from top to bottom, any desired number of belts being employed. Usually, however, one is located at each side of the flooring and the other at the center, the various belts being connected by slats 20. A shaft 21 is journaled in the bottom portion of the elevator, and the said shaft has secured thereon pulleys 22, corresponding in number to the number of belts 19 employed, while a corresponding number of pulleys 23 are similarly located at the top of the elevator, as shown in Fig. 3. These upper pulleys may be provided with independent spindles or may be mounted upon a single shaft. The lower shaft 21 is also provided, preferably at its right-hand end, with a sprocket-wheel 24.

The driving-shaft 25 is mounted to turn in suitable bearings formed in the rear portion of the side pieces 10 of the frame. The shaft extends well beyond the sides of the said frame and likewise serves as a rear axle, having mounted upon its extremities rear supporting-wheels 26, larger than the forward supporting-wheels 15, and the rear supporting-wheels 26 are much wider apart than the forward supporting-wheels, since the rear portion of the machine and the elevator or carrier are wider than the forward axle.

The wheels 26 are adapted to turn or revolve the shaft or rear axle 25 when the wheels travel in a forwardly direction, but the wheels turn loosely upon said shaft or axle when the machine is made to travel back. This is accomplished by the mechanism shown in detail in Fig. 5, in which the hub of the wheel is provided with a circular chamber in its inner face having ratchet-teeth 27 in the peripheral wall thereof, and a wheel 28 is secured upon the axle or shaft in any approved

manner, having pivotally connected with it a dog 29, controlled by a spring 30, the spring holding the dog in engagement with the ratchet-teeth 27.

5 The wheel carrying the dog 29 at the right-hand side of the machine is plain, while the wheel at the left-hand side is a gear, and in order that the two wheels shall not be confounded the geared wheel is designated as
10 28^a and is secured to the axle by a pin or screw 28^b. These wheels 28 and 28^a are located outside of the side bars 10 of the rear frame, as is best shown in Fig. 1. A cylinder B, preferably hollow and provided at each
15 end with a head, is loosely mounted upon the shaft or axle 25, the heads being adapted to prevent the grain or straw carried up by the cylinder from slipping from its ends, and the heads likewise serve to shield the grain from
20 the action of the wind.

The cylinder B is removably connected to the axle by means of a pin or key 31^a, which is passed through a part of the cylinder and through the axle or which is otherwise engaged with the said parts, and which upon
25 removal renders the cylinder free to revolve on the axle and independent thereof. When the pin or key 31^a of the cylinder B is in place, the cylinder will be driven at the same
30 speed as the rotation of the axle. Means are provided for driving the cylinder at a faster speed and the same will be hereinafter described.

31 indicates a sprocket-wheel which is fixed
35 to the axle and which has a chain 32 operating with it, the said chain also operating with a sprocket 24, fixed to the carrier-shaft and whereby the said carrier is driven.

Shafts 33 are mounted to turn in the heads
40 of the cylinder B, and a portion of each shaft is contained within the cylinder and a portion is at the exterior thereof, suitable slots or openings 34 being made in the cylinder between its heads to receive the said shafts
45 33. These shafts are preferably made tubular, so that they may be light, and are provided with series of fingers 35 projecting from the outer side, and as the cylinder revolves in an upwardly direction the fingers
50 will curve or incline in direction of the elevator or carrier.

The finger-shafts 33 are actuated by attaching to their outer ends crank-arms 36, as shown in Fig. 2, and these arms are adapted
55 at a certain point in the revolution of the cylinder to engage with and travel upon segmental tracks 37, secured to the frame or to any fixed support, one track opposite each head of the cylinder and at the rear upper
60 and lower portion of the frame. When the cylinder is revolved the crank-arms 36, that engage with the tracks 37, will hold the fingers 35 of the finger-shafts at an angle to the cylinder, or in position to receive and carry upward any straw that they may gather. When,
65 however, the finger-shaft approaches the ele-

vator or carrier, its crank-arms will slip or disengage from the tracks 37. Consequently the fingers on that shaft may fold back against
70 the cylinder and permit the straw carried to drop cleanly upon the elevator, and the said shaft and its fingers will readily pass the lower edge of the elevator in the further revolution of the cylinders. The fingers will remain in their
75 folded position beneath the cylinder until the crank-arms of the shafts upon which they are mounted again contact with the tracks 37, owing to the said crank-arms acting as weights to hold them in this position, and by this means the fingers 35 are prevented from striking any
80 obstruction that may be beneath the cylinder.

Fig. 4 illustrates the means for rotating the cylinder independently of the shaft or axle and at increased speed. Referring to the same a gear 38 is secured upon the left-hand
85 end of the cylinder, opposite the gear 28^a and independent of the axle, the said gear 38 being adapted to mesh with a gear 39, connected with a gear 40 by a shaft 41, the gear 40 being capable of meshing with the gear 28^a.
90 The shaft connecting the gears 39 and 40 is located in an eccentric bearing 42, provided with a hand-lever 43, whereby when the bearing is moved in one direction the gears 39 and 40 will be in mesh with the gears 28^a and 38,
95 respectively, and when the hand-lever is manipulated in the opposite direction the gears 39 and 40 will be thrown out of mesh with the gears 28^a and 38.

It will be understood that when the gearing
100 shown in Fig. 4 is employed the pin is removed from the hub of the cylinder B, thus making the cylinder loose upon the shaft, and the movements will be as follows: As the rear-ground-wheels revolve forwardly, the gear
105 28^a will be revolved through the medium of the dog 29 carried thereby, and will communicate motion to the gear 39, and the said gear 39 will revolve the cylinder by meshing with the gear 38 attached thereto. Rake-teeth
110 44 are located at the rear of the machine, and the said rake-teeth are mounted in a head 45, pivoted in standards 46, projected upward from the rear portion of the side bars 10 of the frame. The said teeth are secured at their upper ends
115 in the head 45, and are then carried forwardly in a horizontal direction, then vertically downward in front of the head, and are finally curved rearwardly beneath the head around the cylinder and are adapted to engage with
120 the ground at their lower ends. The hook or loop portions of the rake-teeth are made to pass through staples or keepers 47, secured to the forward portion of the head and provided with springs 48, against which the teeth
125 have bearing when their lower ends are carried rearward by meeting any obstruction. Thus the rakes are yielding at their lower ends to a predetermined extent, and are returned to their normal position as soon as the
130 obstruction is passed.

The object of arranging the teeth in front

of the head is to inclose the cylinder as much as possible to protect the hay from the wind. Furthermore, it gives the cylinder teeth or fingers a chance to clean the rake-teeth and take the hay therefrom in a more perfect manner. The fingers on the cylinder-shafts pass up between the rake-teeth and substantially in engagement with sundry of them, so that the fingers will keep the rake-teeth perfectly clean and prevent the possibility of clogging.

A lever 49 is secured to the rake-head, preferably at one end, provided with a thumb-latch 50, engaging with a rack 51, attached to one of the standards 46, and by manipulating the lever 49 the rake-teeth may be raised or lowered, as shown in Fig. 2, and when the rake-teeth have been lowered to their full extent and the loader is used on uneven ground a spring 52 may be attached to the lever 49 and to the frame in order to hold the teeth down and keep said teeth in engagement with the surface of the ground should the wheels pass over a stone or other obstruction in their path.

In the operation of this machine the hay is gathered by the rake and is taken from the rake-teeth by the fingers of the cylinder and is delivered by said cylinder to the elevator

or carrier, from whence it is delivered to the vehicle to be loaded.

The machine is exceedingly simple, economic, and durable.

In windy weather a wind-brake is applied to the sides of the elevator, preferably made of canvas and provided with sticks to enter the staples shown in Fig. 2. By sinking the shafts 33 in the cylinder B the straw is prevented from snarling and the teeth fold close to the cylinder. By providing for a change of speed the loader may be made to gather all the hay placed in windrows by a horse hay-rake.

Having thus described my invention, I claim as new and desire to secure by Letters Patent—

The combination of the wheeled frame, the rake teeth thereon, the cylinder rotatably mounted on the frame, and provided with longitudinal slots and finger-carrying shafts located in said slots, and an elevator on which the fingers are arranged to deliver the hay gathered by the rake teeth, substantially as described.

AUGUST WESTMAN.

Witnesses:

M. THURIN,
JAS. JENSEN.