

(No Model.)

2 Sheets—Sheet 1.

J. BLAKEY.
STAPLE DRIVING IMPLEMENT.

No. 525,581.

Patented Sept. 4, 1894.

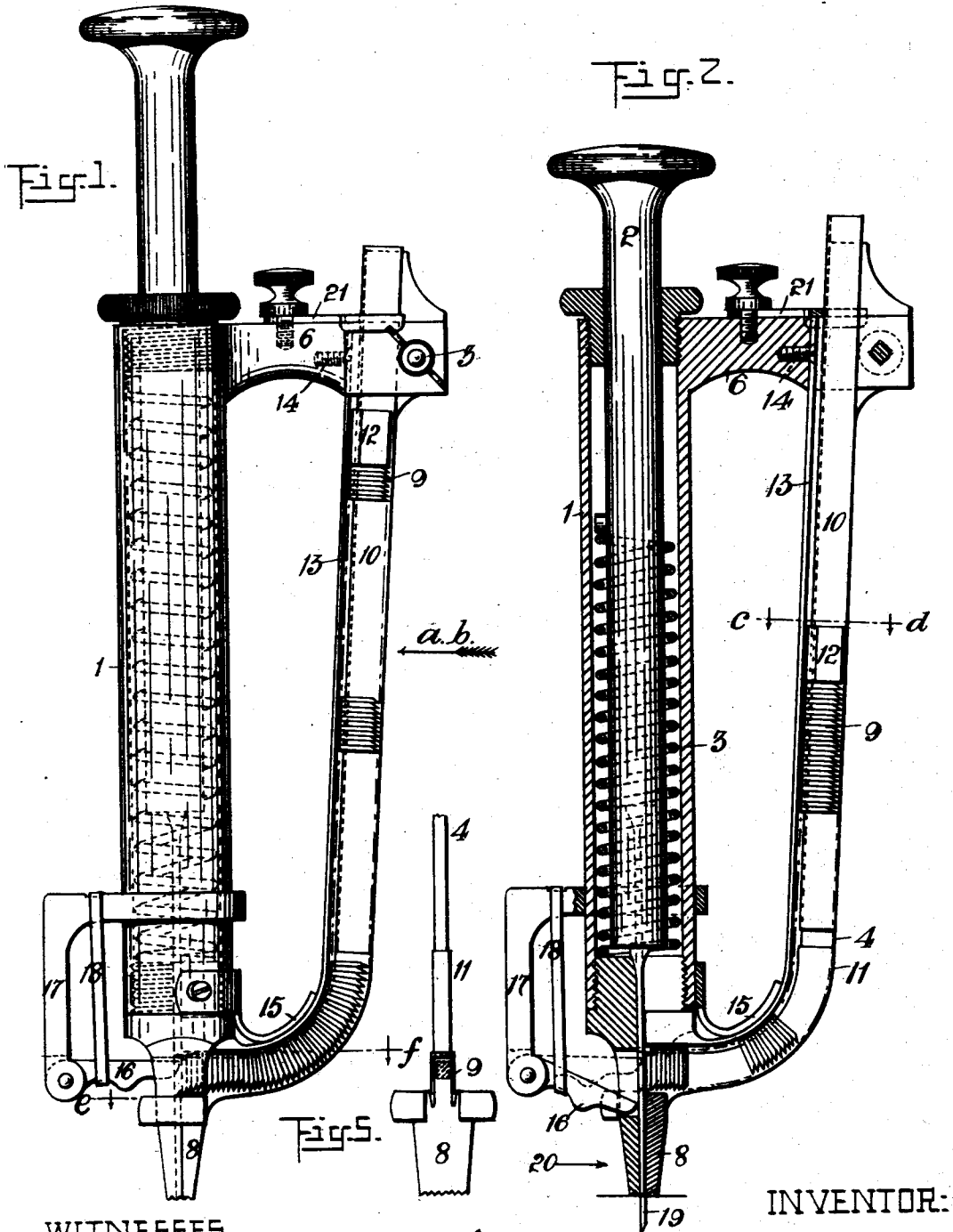

WITNESSES.
Arthur B. Crossley
William H. Tompsett

INVENTOR:
John Blakey

(No Model.)

2 Sheets—Sheet 2.

J. BLAKEY.
STAPLE DRIVING IMPLEMENT.

No. 525,581.

Patented Sept. 4, 1894.

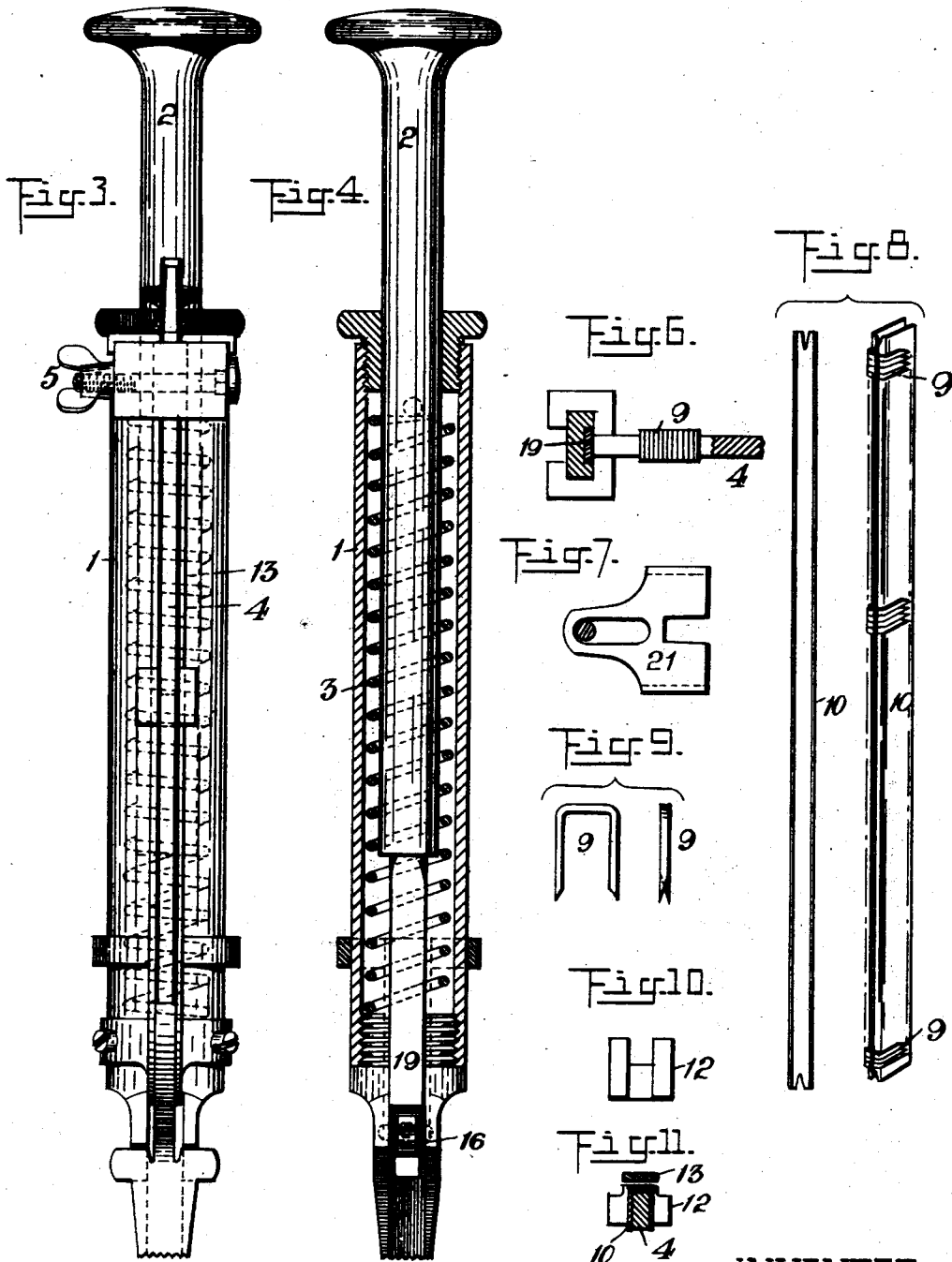

WITNESSES:

Arthur B. Crossley
William H. Tompkins

INVENTOR:

John Blakey

UNITED STATES PATENT OFFICE.

JOHN BLAKEY, OF LEEDS, ENGLAND.

STAPLE-DRIVING IMPLEMENT.

SPECIFICATION forming part of Letters Patent No. 525,581, dated September 4, 1894.

Application filed April 23, 1894. Serial No. 508,646. (No model.) Patented in England February 13, 1893, No. 3,134.

To all whom it may concern:

Be it known that I, JOHN BLAKEY, a subject of the Queen of Great Britain, residing at Leeds, in the county of York, England, have
5 invented certain new and useful Improvements in Apparatus for Driving Staples into the Soles of Boots and Shoes and other Articles, (for which I have obtained a patent in England, No. 3,134, dated February 13, 1893;) and I do hereby declare the following to be a full, clear, and exact description of the invention, such as will enable others skilled in the art to which it appertains to make and use the same.

15 This invention consists in arranging and constructing a new form of hammer or instrument for holding and inserting staples into boots and shoes and other articles, but the said hammer may also be used for inserting
20 staples into upholstery work.

Such being the nature and object of my invention, I will now make reference to the accompanying sheets of drawings illustrative thereof, wherein—

25 Figure 1 is a side elevation of my improved staple driving apparatus. Fig. 2 is a vertical section of same. Fig. 3 is an end view looking in the direction of the arrow *a*, *b*, in Fig. 1, and Fig. 4 is a vertical section of Fig. 3.
30 Fig. 5 is a detail view of bar 4 looking in the direction of the arrow 20 in Fig. 2. Fig. 6 is a sectional plan view taken on line *e f* in Fig. 1. Fig. 7 is a plan view of the plate 21. Fig. 8 is an edge and side view of the trough 10.
35 Fig. 9 is a detail front and side view of a staple. Fig. 10 is a detail view of the weight 12. Fig. 11 is a section taken on the line *c d* in Fig. 2.

The apparatus consists of an outer tube or
40 casing 1 within which is a piston or plunger 2. The piston is forced downward by the operative for the purpose of inserting a staple, but the said piston is raised or forced back by spiral spring 3. The rack or staple holder
45 consists of a flat bar 4 secured at its upper end by screw 5 to an arm 6 projecting from the tube 1 while the bottom of the rack 4 forms part of the foot of the hammer 8.

50 The staples 9, one of which is shown on an enlarged scale at Fig. 9, may be passed over

the rack 4 but for the sake of convenience I first of all pass the staples over a trough 10 shown in edge and side views respectively at Fig. 8, and this trough charged with staples is slid over the rack or bar 4 as shown in
55 Figs. 1 and 2 the bottom of the trough resting against a thickened part 11 of the said bar 4, a weight 12 (see Fig. 10) being employed to rest upon the staples and to insure that the staples follow after each other. 60

Fig. 11 is a section through *c* and *d* of Fig. 2 showing the weight 12, bar 4 and trough 10 in position.

The staples 9 are prevented from falling
65 away from the bar 4 by means of a metal plate or strap 13 the upper end of which is connected by a screw 14 while the bottom part is brazed or soldered to the bracket 15 connected to the bottom of the tube 1. The staples 9 gravitate or are assisted by the
70 weight 12 to the bottom of the bar 4, the first one being engaged or received on the point of the hinged finger 16 connected to the arm 17, the said hinged finger 16 being forced into position by an elastic spring 18 so that on
75 the piston being made to descend the narrowed or contracted part 19 on the bottom thereof, forces its way downward taking with it the staple which is resting on the toe of the hinged lever 16, which staple is driven into
80 the boot or other object. During the downward motion of the piston the finger 16 is pushed away from the staples (see Fig. 2), but as soon as the piston has ascended through the force of the spring 3 the finger 16 is forced
85 into position again by the spring 18 so as to catch the next staple to hold it in readiness for being forced down by the piston, and this operation is repeated so long as there are any staples on the bar 4. Fig. 5 is a detail of bar
90 4 looking in the direction of arrow 20 in Fig. 2, and Fig. 6 is a sectional plan on lines *e* and *f* of Fig. 1, while Fig. 7 is a plan of adjustable plate 21 employed to force the trough 10 against the bar 4. 95

I claim as my invention—

1. The combination, with the piston for driving the staples, of a staple holder provided with the bar 4 having a curved and thickened portion 11 at its lower part and the part 8 at 100

its bottom, a trough for carrying the staples slipped over the said bar and resting on the portion 11, and the guard plate 13, substantially as set forth.

5 2. The combination, with the piston and its inclosing tube provided with the projecting arm 6 at the top, of the bar 4 secured to the bottom of the tube and to the said arm, the
10 trough for carrying the staples, the plate 21 adjustably secured to the arm 6 and operat-

ing to force the said trough against the said bar, and the guard plate 13, substantially as set forth.

In testimony whereof I affix my signature in presence of two witnesses.

JOHN BLAKEY

Witnesses:

ARTHUR B. CROSSLEY,

WILLIAM H. TEMPEST,

Both of Commercial Street, Halifax.