

R. B. BENJAMIN.
ELECTRIC LAMP FIXTURE.
APPLICATION FILED MAY 26, 1904.

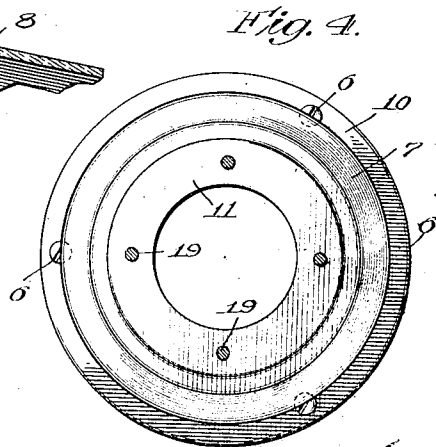
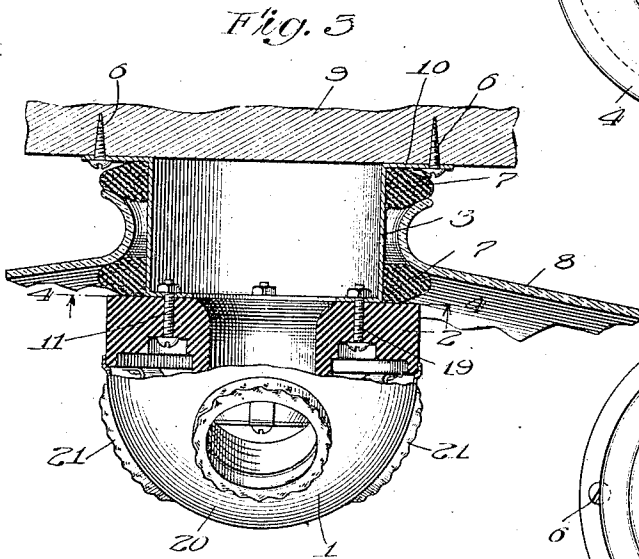
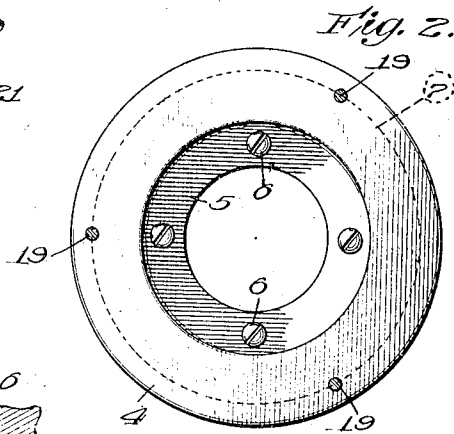
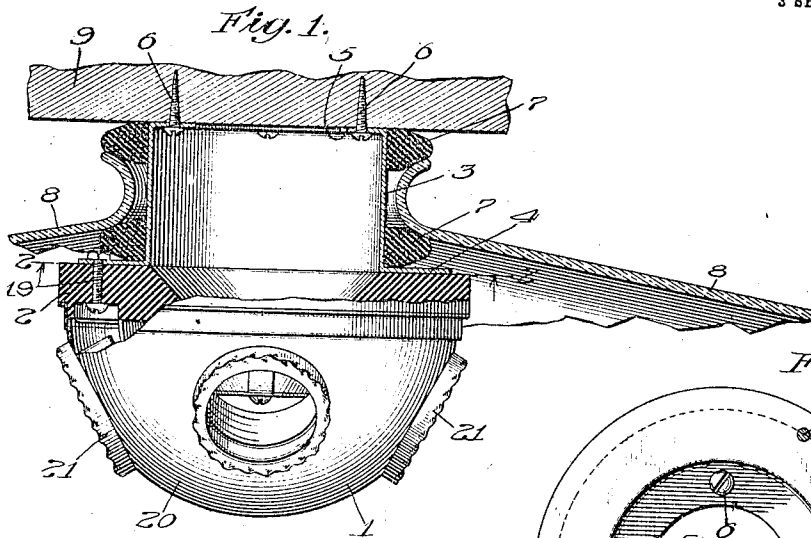

Witnesses:
Robert H. Fein
Curtis B. Lamb

Inventor:
Rush B. Benjamin
By Jones & Addington
Attorneys

No. 825,445.

PATENTED JULY 10, 1906.

R. B. BENJAMIN.
ELECTRIC LAMP FIXTURE.
APPLICATION FILED MAY 26, 1904.

3 SHEETS—SHEET 2.

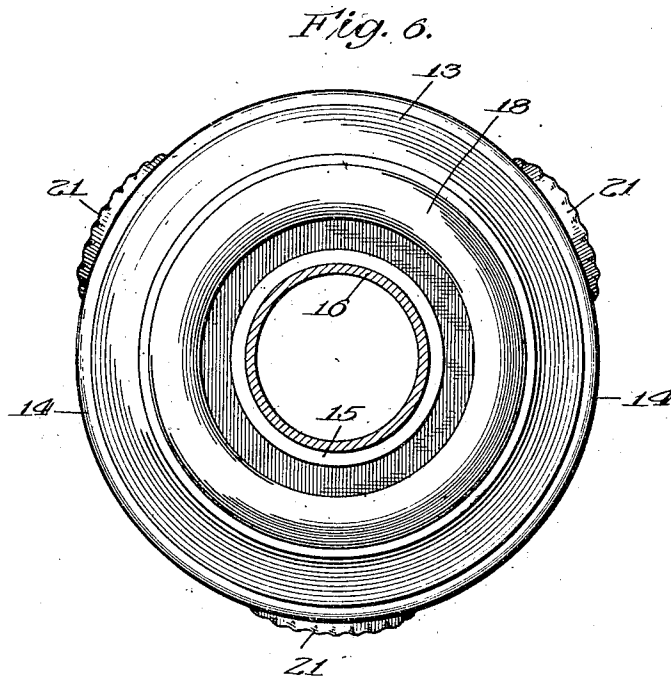
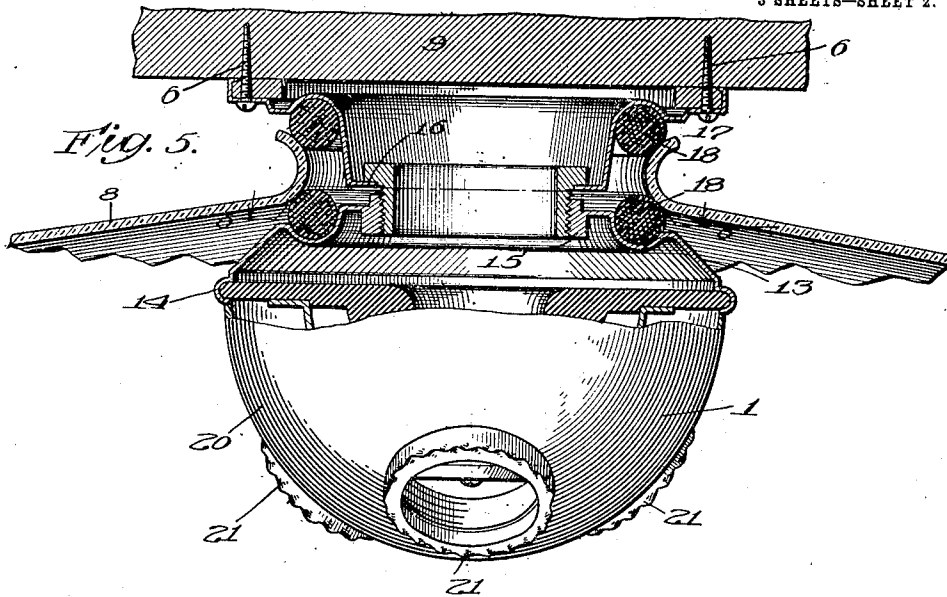

Witnesses:
Robert J. Allen
Curtis B. Lamb

Inventor:
Reuben B. Benjamin
By Jones & Liddington
Attorneys

No. 825,445.

PATENTED JULY 10, 1906.

R. B. BENJAMIN.
ELECTRIC LAMP FIXTURE.
APPLICATION FILED MAY 26, 1904.

3 SHEETS—SHEET 3.

Fig. 7.

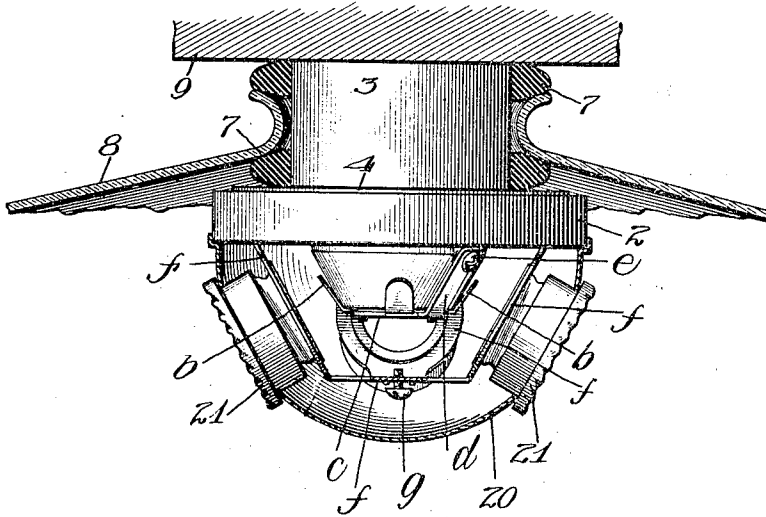

witnesses:

Robert A. Weir
W. Perry Halm

Inventor:

Reuben B. Benjamin
By James A. Addington
Attys

UNITED STATES PATENT OFFICE.

REUBEN B. BENJAMIN, OF CHICAGO, ILLINOIS.

ELECTRIC-LAMP FIXTURE.

No. 825,445.

Specification of Letters Patent.

Patented July 10, 1906.

Application filed May 26, 1904. Serial No. 209,921.

To all whom it may concern:

Be it known that I, REUBEN B. BENJAMIN, a citizen of the United States, residing at Chicago, in the county of Cook and State of Illinois, have invented new and useful Improvements in Electric-Lamp Fixtures, of which the following is a full, clear, concise, and exact description, reference being had to the accompanying drawings, forming a part of this specification.

My invention relates to electric-lamp fixtures.

One of the objects of my invention is the provision of novel means for associating a suitable shade with a plural lamp-socket.

The other objects and novel features of my invention will more fully appear from the following description thereof and from the accompanying drawings, in which I have illustrated embodiments of my invention which I have designed for commercial purposes and which illustrate the general adaptation of my invention to commercial use.

Referring to the drawings, Figure 1 is a sectional view of one form of my invention. Fig. 2 is a view taken on the line 2 2 of Fig. 1 looking in the direction of the arrows. Fig. 3 is a sectional view of another form of my invention. Fig. 4 is a view on the line 4 4 of Fig. 3. Fig. 5 is a sectional view of another form of my invention. Fig. 6 is a view taken on the line 6 6 of Fig. 5; and Fig. 7 is a sectional view of the form of my invention shown in Fig. 1, showing the construction and arrangement of parts within the inclosing casing 20.

Referring to the drawings by reference characters, in which like reference-numerals are used to designate like parts in the several figures, a plural lamp-socket 1 is provided adapted to mechanically support and electrically connect in circuit a plurality of electric lamps. The plural lamp-socket 1 may be of any desired construction; but I prefer to use a plural lamp-socket of the type known as "wireless cluster-sockets," as shown in the United States Letters Patent granted to me as assignor to the Benjamin Electric Manufacturing Company, a corporation of Chicago, Illinois, said Letters Patent being dated March 3, 1903, and numbered 721,774. The socket 1 is secured in any suitable manner to a base 2 and has an inclosing casing or shell 20, adapted to inclose the live parts of the

socket, provided with apertures arranged to receive the lamp-bases, insulating-bushings 21 being preferably disposed within said apertures to insulate the outer lamp-contacts from the said casing. The base 2 is secured to a subbase 3 in any suitable manner, as by bolts or screws 19. The subbase 3 has an outwardly-extending flange adapted to engage the bolts 19 and an inwardly-extending flange 5 for securing the fixture to the ceiling or other support 9, screws 6 6 being used for that purpose.

Disposed upon the subbase 3 are rings 7 7, of soft rubber or other resilient material, the surfaces of which are preferably beveled to engage the convex surface of the cluster or socket shade 8. The shade, of which any desired form may be used, is resiliently mounted upon the rings 7 7, which support the same slightly out of engagement with the subbase to prevent injury to the shade in coming in contact with said subbase, as shown in Fig. 1.

Any desired method of securing the plural lamp-socket 1 and the shade 8 in proper relative positions may be substituted in lieu of that above described without departing from the spirit of my invention, and any desired means for resiliently mounting the shade 8 may be provided in lieu of the rings 7 7, or the resilient mounting may be omitted.

It will be noted that in installing my improved socket the resilient rings 7 7 and the shade 8 are first placed in position upon the subbase 3 and said subbase secured to the support 9, after which the base 2, upon which the socket 1 is carried, is secured to the subbase by the bolts or screws 19.

Referring to Figs. 3 and 4, the subbase 3 has an outwardly-extending flange 10 for securing the fixture in position upon the ceiling or other suitable support 9 and also carries a preferably inwardly extending flange 11 for securing the base 12 of the plural lamp-socket 1 to said subbase. It will be noted that a smaller socket may be mounted upon the base 3, which has the inwardly-extending flange 11, than is mounted upon the subbase having the outwardly-extending flange, as shown in Fig. 1, while permitting the same-sized shade 8 to be carried by the subbase 3. The particular form of base 2 and subbase 3 are not essential, as any desirable form of base and subbase for supporting the socket 1 and shade 8 in proper relative positions may be

adopted, and any desired means for securing the subbase to the support 9 and base 2 may be adopted in lieu of the screws 6 and bolts 19.

In installing the form of my invention shown in Figs. 3 and 4 the subbase 3 is first secured in position and the shade 8 with its resilient mounting 7 placed in position upon the subbase, the base 2 when secured to the subbase serving to secure the shade 8 in position thereon.

Referring to Figs. 5 and 6, a suitable base 13 is secured to the plural lamp-socket 1 in any suitable manner, preferably by having the extended edge 14 of the base turned or spun over a small annular projection carried by the plural lamp-socket 1. An internally-screw-threaded bushing 15, carried on the base 13, engages a screw-threaded bushing 16, carried on the subbase 17, which is secured to the support 9 by means of screws or bolts 6 6 or in any other suitable manner, whereby the socket is removably supported. Resilient rings 18 18, preferably made of soft rubber, are preferably disposed within recesses formed in the base 13 and subbase 17 to form a resilient mounting for the shade 8. The screw-threaded bushings 15 and 16 are not essential, as any desired means for securing the base 13 to the subbase 17 may be adopted in lieu of said screw-threaded bushings 15 and 16.

In installing the form of my invention shown in Figs. 5 and 6 the subbase 17 is first secured in position and the shade and resilient rings 18 18 being disposed between the subbase and the base 13 said bases are adjusted to their proper positions by means of the screw-threaded bushings 15 and 16. It will be noted that the bushings constitute an adjustable connection between the base 13 and the subbase 17, which permits the resilient rings 18 18 to be adjusted to accommodate lamp-shades 8 of slightly-different size and shape.

My invention is particularly applicable to so-called "plural" lamp-clusters, in which there is a suitable basic or supporting part and an inclosing casing associated therewith and having suitable lamp-openings, the electrical conducting parts of the socket being inclosed within the casing. My invention provides a convenient and effective means for supporting a plural cluster of this type in position, while at the same time accommodating a reflector or shade. The combined support and shade-holder presents a cylindrical body or spindle, which is mounted upon the rear of the basic portion of the cluster, to thus form an annular space at the rear of the cluster for the reception of the flange of the reflector or shade. Preferably a pair of resilient rings is placed in this annular space, between which rings the flange of the shade may be interposed. As before stated, however, these resilient rings may be omitted

and other suitable means provided for securing the shade in position in the annular space. I have shown in the drawings and described several different modifications of my invention, all of which, however, embody the same general principle. In the modification shown in Figs. 1 and 3 the combined support and shade-roller is secured to the basic part of the cluster by means of screws. In Fig. 5 I have shown a modification wherein the basic part of the cluster is provided with a central threaded aperture, while the combined support and shade-holder carries a threaded stud, with which the threaded aperture is adapted to engage. This modification possesses advantages over that shown in the other figures, inasmuch as the shade can be removed or placed in position by simply unscrewing the cluster.

As shown in Fig. 7, it will be noted that the base 2 has a central projection on which is carried upturned contacts *b*, supported in position and electrically connected by a ring *c*, and which form the central contacts for the lamps. The ring *c* is provided with an offset upturned projection *d*, having at the upper end thereof a binding-post *e*, to which one of the leading-in wires may be connected. A contact-plate having upturned portions *f*, provided with openings to permit the central terminal of the lamp to engage the contacts *d*, is also supported on the base 2 and is provided with threaded shells adapted to support the lamps in position and upon which are secured the insulating-bushings 21. A binding-post *g* is mounted upon the contact-plate, to which the opposite leading-in wire may be secured. By this arrangement it will be noted that all of the electrical conducting parts of the cluster are inclosed within the casing 20.

Having described my invention, what I claim as new, and desire to secure by Letters Patent, is—

1. The combination with a plural lamp-cluster, having a suitable basic part and an inclosing casing with suitable lamp-openings, the electrical conducting parts of the cluster being inclosed within said casing, of a cylindrical metallic combined support and shade-holder detachably connected to the basic part of said cluster and of less diameter than said basic part to leave an annular space in the rear of said cluster for the reception of the flange of a shade.

2. The combination with a plural lamp-cluster, having a suitable basic part and an inclosing casing with suitable lamp-openings, the electrical conducting parts of the cluster being inclosed within said casing, of a cylindrical metallic combined support and shade-holder detachably connected to the basic part of said cluster and of less diameter than said basic part to leave an annular space in the rear of said cluster for the reception of

the flange of a shade, and a pair of rings of resilient material surrounding said cylindrical support and lying in said annular space, between which rings the flange of a shade is adapted to be held.

3. The combination with a plural lamp-cluster, having a back plate with a central threaded opening and an inclosing casing having suitable lamp-openings, the electrical conducting parts of the cluster being inclosed within said casing of a combined cluster-support and shade-holder having an externally-threaded stud to engage said central threaded aperture.

4. The combination with a plural lamp-cluster, having a back plate with a central threaded opening and an inclosing casing having suitable lamp-openings, the electrical conducting parts of the cluster being inclosed within said casing, of a combined cluster-support and shade-holder having an externally-threaded stud to engage said central threaded aperture, and having a flange, between

which flange and the body of the lamp-cluster a shade is adapted to be interposed.

5. The combination with a plural lamp-cluster, having a back plate with a central threaded opening, and an inclosing casing having suitable lamp-openings, the electrical conducting parts of the cluster being inclosed within said casing, of a combined cluster and shade-holder having at one end an externally-threaded stud to engage said central threaded aperture, and having at the other end a flange, and a pair of resilient rings, interposed between said flange and the body of the lamp-cluster, between which rings a shade is adapted to be interposed.

In witness whereof I have hereunto subscribed my name in the presence of two witnesses.

REUBEN B. BENJAMIN.

Witnesses:

E. R. KING,
M. R. ROCHFORD.