



US00D810707S

(12) **United States Design Patent**  
**Mori et al.**

(10) **Patent No.:** **US D810,707 S**  
(45) **Date of Patent:** **\*\* Feb. 20, 2018**

(54) **FLEXIBLE PRINTED WIRING BOARD WITH DEVICE**

FOREIGN PATENT DOCUMENTS

(71) Applicant: **Sumitomo Electric Industries, Ltd.**,  
Osaka-shi, Osaka (JP)

KR 300415642 S 6/2006

(72) Inventors: **Koji Mori**, Osaka (JP); **Takashi Iwasaki**, Osaka (JP); **Kazumasa Toya**, Osaka (JP); **Kenji Saito**, Osaka (JP); **Yoshiya Abiko**, Osaka (JP); **Youichi Nagai**, Osaka (JP); **Makoto Inagaki**, Osaka (JP); **Rui Mikami**, Osaka (JP)

OTHER PUBLICATIONS

Japanese Office Action for related Japanese Design Patent Application No. 2014-011387 dated Feb. 9, 2015, 2 Pages.

(Continued)

(73) Assignee: **SUMITOMO ELECTRIC INDUSTRIES, LTD.**, Osaka (JP)

*Primary Examiner* — Elizabeth J Oswecki  
(74) *Attorney, Agent, or Firm* — Dithavong & Steiner, P.C.

(\*\*) Term: **15 Years**

(57) **CLAIM**

The ornamental design for a flexible printed wiring board with device, as shown and described.

(21) Appl. No.: **29/586,563**

**DESCRIPTION**

(22) Filed: **Dec. 5, 2016**

**Related U.S. Application Data**

(62) Division of application No. 29/507,495, filed on Oct. 28, 2014, now Pat. No. Des. 784,936.

FIG. 1 is a front view of a flexible printed wiring board with device shown in a used condition mounted on a photovoltaic power device for a photovoltaic module or a light emitting diode device for a light emitting diode module shown in broken lines showing our new design;  
FIG. 2 is a rear view thereof;  
FIG. 3 is a top plan view thereof;  
FIG. 4 is a bottom plan view thereof;  
FIG. 5 is a right side view thereof;  
FIG. 6 is a left side view thereof;  
FIG. 7 is an enlarged top plan view of a portion taken along lines 7-7 of FIG. 3;  
FIG. 8 is an enlarged bottom plan view of a portion taken along lines 8-8 of FIG. 4;  
FIG. 9 is an enlarged front view of a portion taken along lines 9-9 of FIG. 1;  
FIG. 10 is an enlarged rear view of a portion taken along lines 10-10 of FIG. 2;  
FIG. 11 is a right side view of FIG. 7; and,  
FIG. 12 is an enlarged left side view of FIG. 6.

(30) **Foreign Application Priority Data**

May 28, 2014 (JP) ..... 2014-011388  
May 28, 2014 (JP) ..... 2014-011394

(51) **LOC (11) Cl.** ..... **13-03**

(52) **U.S. Cl.**  
USPC ..... **D13/182**

(58) **Field of Classification Search**  
USPC .... D13/155, 182; 174/68.1, 68.2, 68.3, 250, 174/253, 254, 255, 256, 257, 258, 260  
(Continued)

(56) **References Cited**

**U.S. PATENT DOCUMENTS**

3,646,399 A 2/1972 Mars et al.  
3,777,221 A 12/1973 Tatusko et al.

(Continued)

The even dashed broken lines shown in the drawings represent portions of the flexible printed wiring board with device that form no part of the claimed design. The long  
(Continued)

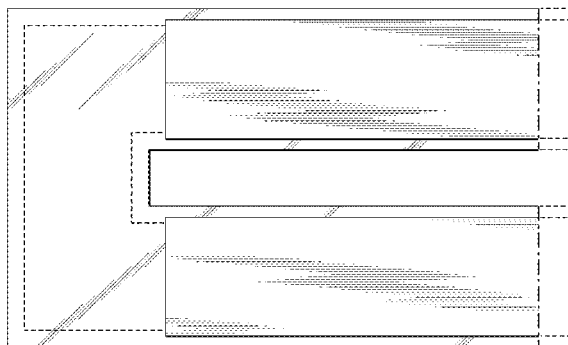
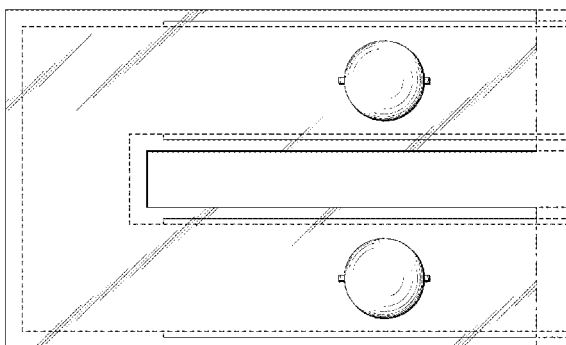

dashed and short dashed line indicates only a boundary line between the claimed and unclaimed areas of the design.

**1 Claim, 4 Drawing Sheets**

(58) **Field of Classification Search**

CPC ..... H05K 3/36; H05K 3/361; H05K 3/363; H05K 3/365; H05K 3/40; H05K 3/4007; H05K 3/4015; H05K 3/0062; H05K 3/28; H05K 3/281; H05K 2201/0999; H05K 2201/09818; H05K 2201/04; H05K 2201/05; H05K 2201/051; H05K 2201/052; H05K 2201/053; H05K 2201/055; H05K 2201/056; H05K 2201/057; H05K 2201/058; H05K 2201/0715; H05K 1/0393; H05K 1/118; H05K 1/028; H05K 1/0281; H05K 1/0283

See application file for complete search history.

(56) **References Cited**

U.S. PATENT DOCUMENTS

D363,920 S 11/1995 Roberts et al.  
 D397,093 S 8/1998 Kim  
 7,067,912 B2\* 6/2006 Takeuchi ..... H01L 23/49827  
 174/255  
 D548,201 S 8/2007 Jones  
 7,405,479 B2\* 7/2008 Kanagawa ..... G11B 5/4846  
 257/738  
 7,466,519 B2\* 12/2008 Wakaki ..... G11B 5/486  
 174/255  
 D601,520 S 10/2009 Yokota et al.  
 7,616,452 B2 11/2009 Wehrly, Jr. et al.  
 D605,613 S 12/2009 Carter et al.  
 7,626,125 B2\* 12/2009 Nakamura ..... H01L 21/76843  
 174/256  
 7,660,126 B2 2/2010 Cho et al.  
 D612,347 S 3/2010 Yokota et al.  
 D615,506 S 5/2010 Eide et al.  
 7,732,900 B2\* 6/2010 Kanagawa ..... G11B 5/4833  
 257/676  
 D637,566 S 5/2011 Cleghorn et al.

D656,111 S 3/2012 Kajiya et al.  
 D656,112 S 3/2012 Kajiya et al.  
 8,134,080 B2\* 3/2012 Ishii ..... H05K 3/38  
 174/255  
 D661,265 S 6/2012 Kajiya et al.  
 8,266,794 B2\* 9/2012 Ishii ..... G11B 5/486  
 29/602.1  
 D669,045 S 10/2012 Kajiya et al.  
 D669,046 S 10/2012 Kajiya et al.  
 D687,397 S 8/2013 Kajiya et al.  
 8,760,815 B2\* 6/2014 Ishii ..... G11B 5/484  
 360/245.8  
 8,866,027 B2\* 10/2014 Oka ..... H05K 3/44  
 174/262  
 D757,666 S 5/2016 Yokoo  
 9,572,259 B2\* 2/2017 Terada ..... H05K 1/181  
 D784,936 S \* 4/2017 Mori ..... D13/182  
 D785,575 S \* 5/2017 Mori ..... D13/182  
 2002/0007961 A1\* 1/2002 Yamato ..... G11B 5/486  
 174/250  
 2004/0080569 A1\* 4/2004 Silverbrook ..... B41J 2/14024  
 347/42  
 2005/0217895 A1\* 10/2005 Maharshak ..... H05K 1/0287  
 174/262  
 2006/0125067 A1\* 6/2006 Wehrly, Jr. .... H05K 1/189  
 257/679

OTHER PUBLICATIONS

Japanese Office Action for related Japanese Patent Application No. 2014-011389 dated Feb. 9, 2015, 2 Pages.  
 Japanese Office Action for related Japanese Patent Application No. 2014-011390 dated Feb. 9, 2015, 2 Pages.  
 Japanese Office Action for related Japanese Patent Application No. 2014-011391 dated Feb. 9, 2015, 2 Pages.  
 Japanese Office Action for related Japanese Patent Application No. 2014-011392 dated Feb. 9, 2015, 2 Pages.  
 Japanese Office Action for related Japanese Patent Application No. 2014-011393 dated Feb. 9, 2015, 2 Pages.  
 Japanese Office Action for related Japanese Design Patent Application No. 2014-011388 dated Jul. 6, 2015, 2 Pages.  
 Oki Electric Cable, "Oki Electric Cable Develops Industry's First FPC for Three-dimension Wiring", Jun. 11, 2008, 5 Pages.

\* cited by examiner

FIG.1

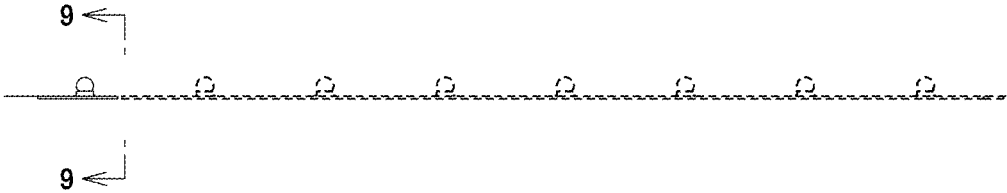

FIG.2

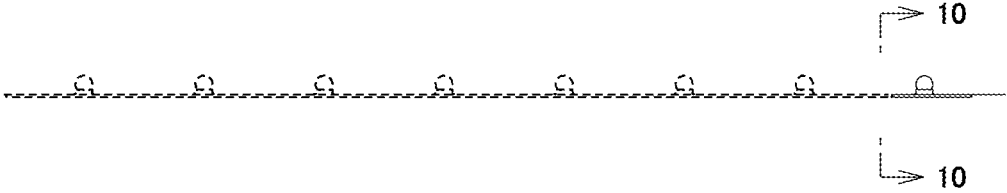

FIG.3

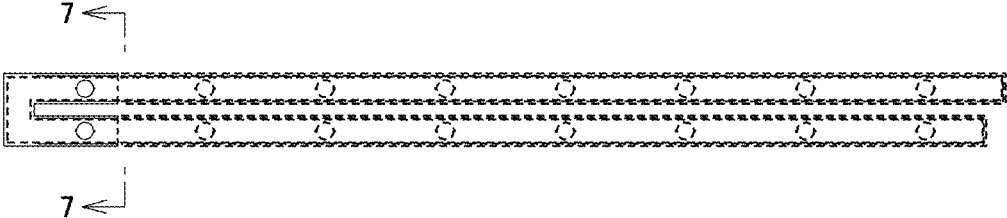

FIG.4

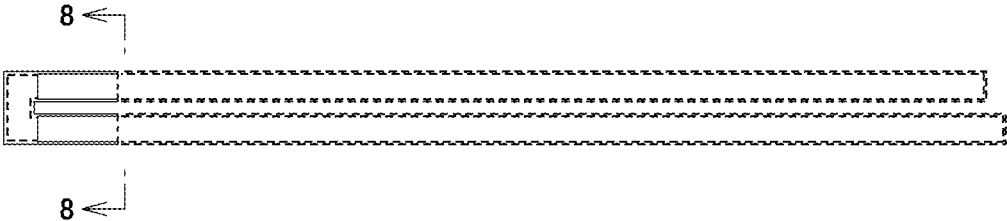

FIG.5



FIG.6



FIG.7

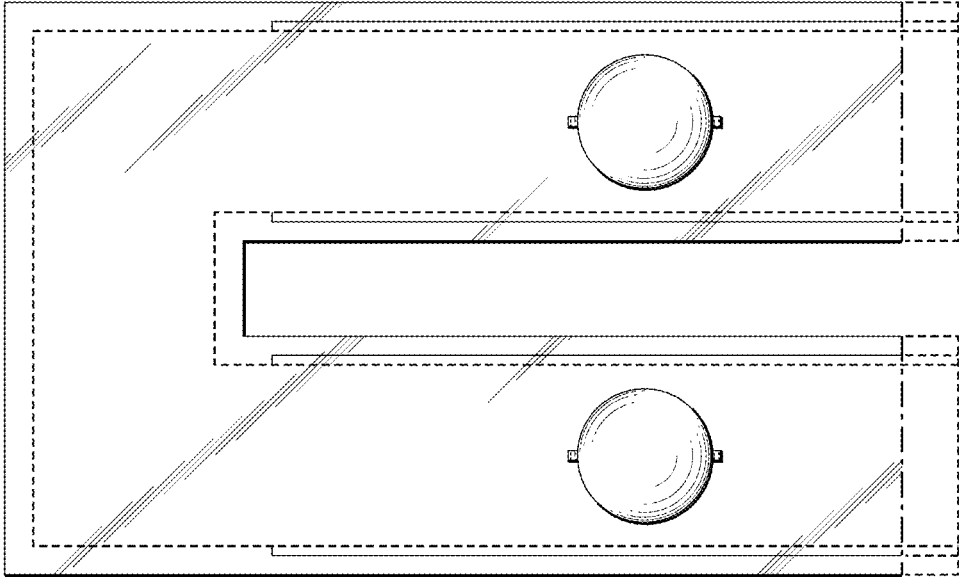

FIG.8

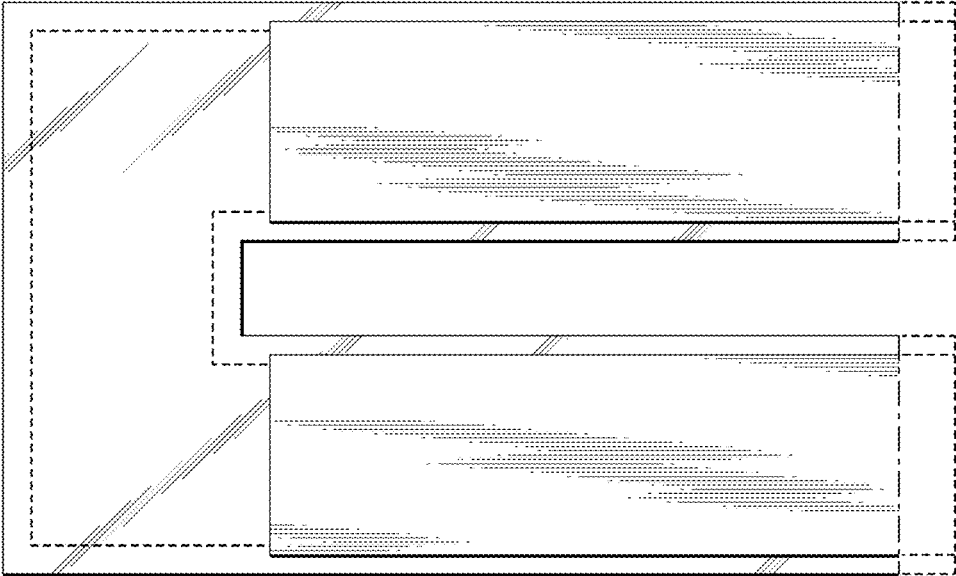

FIG.9

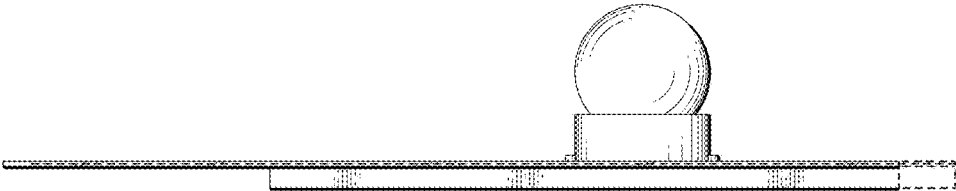

FIG.10

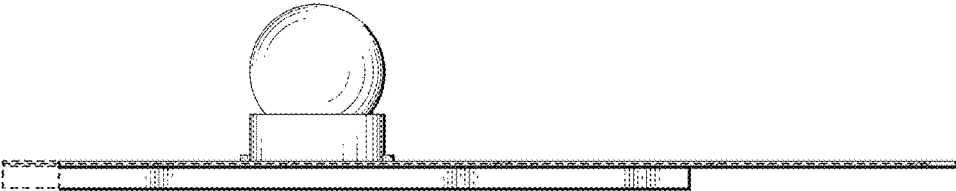

FIG.11

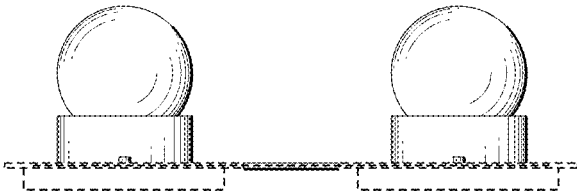

FIG.12

