

(No Model.)

W. A. GUTHRIE.
RAILWAY JOINT.

No. 468,518.

Patented Feb. 9, 1892.

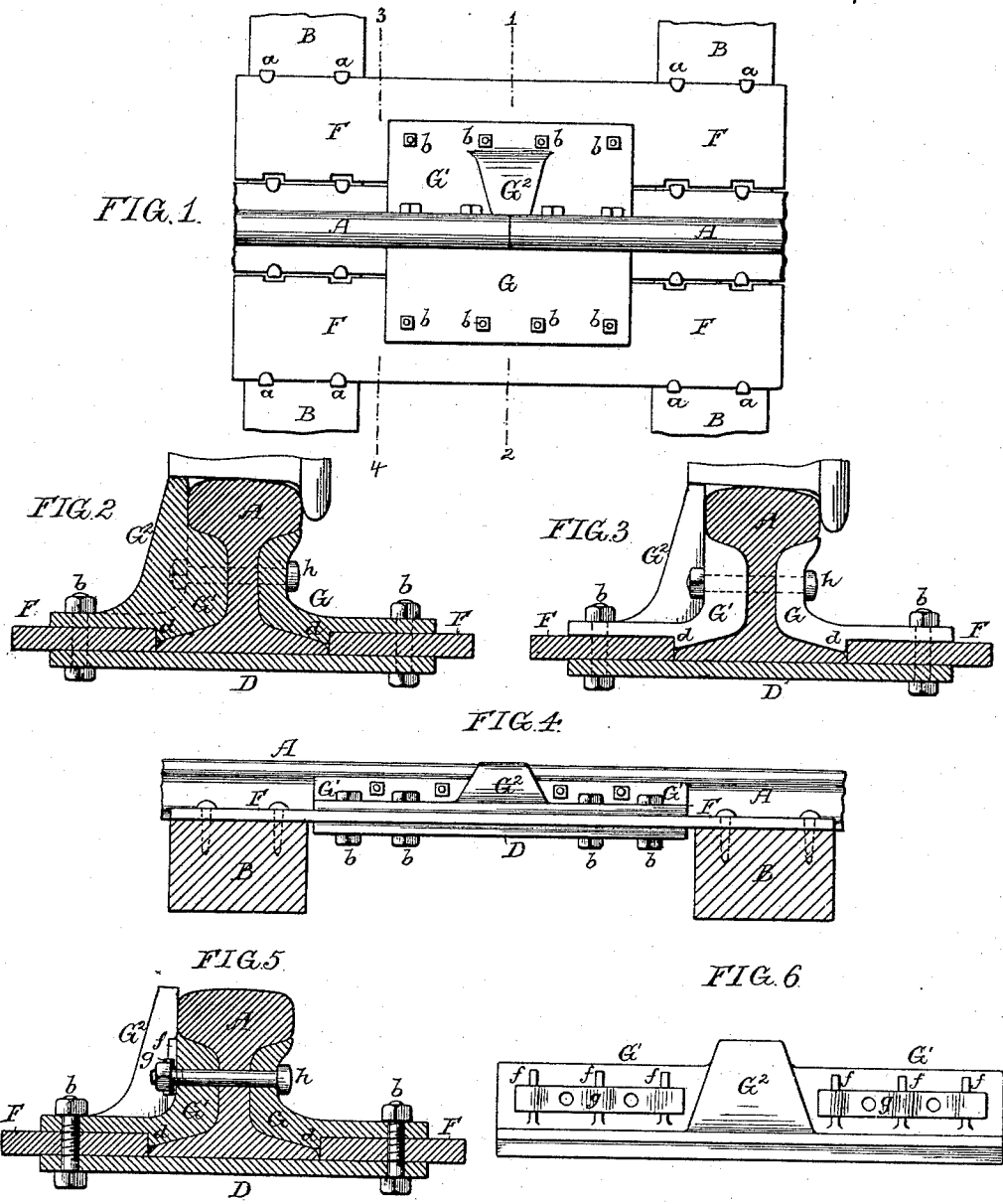

Witnesses
Hamilton D. Turner
R. Schleicher.

Inventor
William A. Guthrie
by Howson & Howson
Attorneys

UNITED STATES PATENT OFFICE.

WILLIAM A. GUTHRIE, OF DURHAM, NORTH CAROLINA.

RAILWAY-JOINT.

SPECIFICATION forming part of Letters Patent No. 468,518, dated February 9, 1892.

Application filed October 5, 1891. Serial No. 407,770. (No model.)

To all whom it may concern:

Be it known that I, WILLIAM A. GUTHRIE, a citizen of the United States, residing in the city and county of Durham, State of North Carolina, have invented certain new and useful Improvements in Railway-Joints, of which the following is a specification.

My invention relates to railroad-rail joints, and has for its object the construction of a simple device whereby the rails may be effectively joined along the line of track, so as to prevent their depression at and near the ends, where they are weakest, on account of the downward pressure of a moving train, and also to prevent their lateral displacement by the pressure of the flanges of the wheels against them, more particularly the lower rail, in passing around a curve, where by the natural law of gravity, the moving train having a lateral motion, as it were, down an inclined plane, the greater weight is thrown laterally against the inside part of the head of the lower rail, and at times, too, with more or less of a shock, tending to spread the rails, especially at the joints.

My object is at the same time to allow for the natural expansion and contraction of the rails in a longitudinal direction and also to adapt my invention to the present well-known state of the art in the construction of railroads, making no changes in the construction of the well-established T-rail, no change in the construction of the rims or periphery of car-wheels, and no change in the use, in the ordinary way, of cross-ties—in short, to provide an invention of practical benefit and one which can be easily adapted to the present state of railroad construction and operation, reducing the wear and tear on the rails themselves and the injury to the rolling-stock in operating the road, and adding to the safety and comfort of employes and passengers.

My invention consists in the particular construction and arrangement of parts hereinafter more fully described, reference being had to the accompanying drawings, in which—

Figure 1 is a plan view of my improved joint for railroad-rails. Fig. 2 is a transverse section of the same on the line 1 2, Fig. 1. Fig. 3 is a transverse section of the same on the line 3 4, Fig. 1. Fig. 4 is a side view of

the joint with parts of the rails and two adjoining cross-ties; and Figs. 5 and 6 are, respectively, a transverse section and a side view illustrating a special form of improved joint. Figs. 2, 3, and 5 are on an enlarged scale.

A A represent the adjoining portions of two railroad-rails, and B B the adjoining cross-ties supporting said rails. The joint comprises five parts, which I term, respectively, the "base-plate," the "inner" and "outer" side plates, and the "inner" and "outer" angle-bars. The base-plate D is somewhat wider than the base-flanges of the rails and is of a length less than the distance between the adjoining cross-ties B B. The side plates F F overlap those portions of the base-plate D which project beyond the flanges of the rails, and said side plates also extend over the cross-ties B B and are securely fastened thereto by spikes *a*, the rails also being spiked to the ties, as usual. The inner and outer angle-bars G G' are bolted to the webs of the rails in the same manner as the ordinary fish-plates and extend up under the heads of the rails and bear upon the base-flanges of the same, and these plates also project out over the side plates F F; bolts *b* passing through these projecting portions of the angle-plates and through the side plates and base-plate, so as to firmly secure the whole structure together. The angle-plates have shoulders *d*, as shown in Figs. 2 and 3, for bearing laterally against the inner faces of the side plates F F, and the outer angle-plate G' has at the joint between the rails a bridge-block G², the top of which is flush with the tops of the rail-heads and also extending upward slightly above the heads of the rails and shaped so as to conform to the outer periphery of the passing wheels, this bridge-block extending some little distance on each side of the joint and sloping downward at its extreme sides to prevent a shock to the wheels in passing over it, as shown in Figs. 1 and 4. The outer angle-bar G' may have upon the outer face vertical ribs *f*, as shown in Figs. 5 and 6, these ribs serving as bearings for elastic plates *g*, against which bear in the spaces between the ribs nuts on the transverse bolts *h* of the joint, the elastic

plates thus exerting a pressure against the nuts to prevent the accidental loosening of the latter.

Having thus set forth the general construction of the joint, I will now give more in detail the objects and advantages of the same. The joint is the weakest part of a railroad-line, as is conceded, and to strengthen the joint or reinforce it is the prime object of my invention. Hence my joint begins with the flat plate underneath the rails and between the cross-ties, such location being usually called a "swinging joint." By the use of the swinging joint I accommodate the base-plate without either depressing the joint-tie below the others on either side of it or cutting away a portion of the top of the cross-tie to accommodate the base-plate, either of which plans would be objectionable, because cutting away the cross-tie involves labor and tends to accumulate rain-water at the point of cutting, more particularly if mortises be cut into the ties, which water will rot the wood, while the depressing of one cross-tie below another has a tendency to rot the whole tie and also to make an uneven road-bed. A swinging joint having the base-plate D, however, is perfectly solid, as the bases of the ends of the rails rest flatly and evenly upon this plate. Hence if the webs and the heads of the rails are uniformly made the tops of the rail-heads must be of exactly the same height, and the rails are thus kept exactly flush with each other on top while receiving the impact and downward pressure of the wheels. When the ends of the rails are uneven on top, the wheels begin to hammer the ends, and the wearing away of the ends increases with the hammering, and whenever there is any hammering there is more or less shock and injury to the rolling-stock, as well as the rails, thus increasing the danger of accidents. Moreover, whenever the joint is depressed on either side from any cause the center of gravity of the moving train at once shifts and the rail on the lower side of the track receives more than its share of the weight of the passing train.

While heretofore in the ordinary use of fish-bar plates the object is to support the ends of the rails by their heads, my invention undertakes, by the use of the base-plates and side plates to which said base-plate is firmly bolted, to begin with a support for the bases of the rails and to use in combination with that the old-style fish-plate head-support with this material addition—namely, that I use stronger fish-bars or angle-joints, and the bases of these bars are pressed firmly against both the tops and inner sides of the side plates, so that they are better supported than they could be if their bases were spiked down to the wooden cross-ties or (as more frequently happens when joint and angle bars now in use have been made to swing between the cross-ties) without any support whatever for the bases of the angle-bars. In my joint the

bases of both the outside and inside angle-bars rest against and are supported by the side plates uniformly throughout the length of the angle-bars, and the side plates may be made strong enough to successfully resist and overcome any pressure, however great and either downward or lateral, that may be exerted upon them. Hence the angle-bars effectually resist pressure both downward and outward and the strain on the bolts which hold the angle-bars together through the webs of the rails is relieved. The bridge-block G^2 serves to carry the wheels over the joint and to stiffen and strengthen the angle-bar G' at the joint both as regards downward and outward pressure. The bolts which hold the base-plate to the side plates can be made as strong as necessary, and the weight of the base-plate keeps the nuts which fasten it to the side plates always locked, while the pressure of the moving train passing the joint tends to lock the nuts the more firmly at the time of greatest need for locking said nuts. When the outer rim or periphery of the wheel is passing the bridge G^2 across the joint between the ends of the rails, lateral as well as downward pressure is exerted upon the top of the outer angle-bar, while the base of the same is supported firmly against the side bar. Hence this outward pressure locks the nuts on the bolts, which pass through the webs of the rails and hold the angle-bars together. If any further locking of these bolts is needed, it is provided for in the construction shown in Figs. 5 and 6, the ribs f between the bolts presenting means for applying the flat piece of steel g and springing it by screwing up the nuts against it.

Having thus described my invention, I claim and desire to secure by Letters Patent—

1. The within-described rail-joint, consisting of a base-plate adapted to support the rails between the ties, opposite side plates secured to the ties and overlapping said base-plate, inner and outer angle-bars adapted to be bolted to and to support the rails and having both a vertical and a lateral bearing upon the side plates, and bolts for securing said base-plate, side plates, and angle-plates together, substantially as specified.

2. The within-described rail-joint, the same consisting of a base-plate adapted to support the rails between the ties, opposite side plates secured to the ties and overlapping the base-plate, inner and outer angle-bars adapted to be bolted to and to support the rails, said angle-bars overlapping the side plates and the outer bar having a bridge-block the top of which extends upward somewhat above the heads of the rails, so as to conform to the outer periphery of the passing wheels, and bolts for securing the base-plate, side plates, and angle-bars together, substantially as specified.

3. The within-described rail-joint, the same consisting of a base-plate adapted to support the rails between the ties, opposite side plates

secured to the ties and overlapping the base-plate, inner and outer angle-bars adapted to be bolted to and to support the rails, said bars projecting over the side plates and one of the
5 bars having ribs serving as bearings for an elastic nut-locking plate, and bolts for securing together the base-plate, side plates, and angle-bars, substantially as specified.

In testimony whereof I have signed my name to this specification in the presence of two subscribing witnesses.

WILLIAM A. GUTHRIE.

Witnesses:

ALBERT POPKINS,
J. FRED. KELLEY.