



(51) International Patent Classification:

*B65F 1/14* (2006.01)      *B65D 83/08* (2006.01)  
*B65F 1/00* (2006.01)      *B65D 77/30* (2006.01)

(21) International Application Number:

PCT/US2016/059104

(22) International Filing Date:

27 October 2016 (27.10.2016)

(25) Filing Language:

English

(26) Publication Language:

English

(30) Priority Data:

62/251,159      5 November 2015 (05.11.2015)      US  
15/193,972      27 June 2016 (27.06.2016)      US

(72) Inventor; and

(71) Applicant : **CASTRO, Deja, S.** [US/US]; 30141 Antelope Rd. D755, Menifee, CA 92584 (US).

(74) Agent: **EVANS, Andrea, H.**; The Law Firm of Andrea Hence Evans, LLC, 14625 Baltimore Ave. #853, Laurel, MD 20707 (US).

(81) Designated States (unless otherwise indicated, for every

kind of national protection available): AE, AG, AL, AM, AO, AT, AU, AZ, BA, BB, BG, BH, BN, BR, BW, BY, BZ, CA, CH, CL, CN, CO, CR, CU, CZ, DE, DJ, DK, DM, DO, DZ, EC, EE, EG, ES, FI, GB, GD, GE, GH, GM, GT, HN, HR, HU, ID, IL, IN, IR, IS, JP, KE, KG, KN, KP, KR, KW, KZ, LA, LC, LK, LR, LS, LU, LY, MA, MD, ME, MG, MK, MN, MW, MX, MY, MZ, NA, NG, NI, NO, NZ, OM, PA, PE, PG, PH, PL, PT, QA, RO, RS, RU, RW, SA, SC, SD, SE, SG, SK, SL, SM, ST, SV, SY, TH, TJ, TM, TN, TR, TT, TZ, UA, UG, US, UZ, VC, VN, ZA, ZM, ZW.

(84) Designated States (unless otherwise indicated, for every

kind of regional protection available): ARIPO (BW, GH, GM, KE, LR, LS, MW, MZ, NA, RW, SD, SL, ST, SZ, TZ, UG, ZM, ZW), Eurasian (AM, AZ, BY, KG, KZ, RU, TJ, TM), European (AL, AT, BE, BG, CH, CY, CZ, DE, DK, EE, ES, FI, FR, GB, GR, HR, HU, IE, IS, IT, LT, LU, LV, MC, MK, MT, NL, NO, PL, PT, RO, RS, SE, SI, SK, SM, TR), OAPI (BF, BJ, CF, CG, CI, CM, GA, GN, GQ, GW, KM, ML, MR, NE, SN, TD, TG).

[Continued on next page]

(54) Title: TRASH BAG APPARATUS

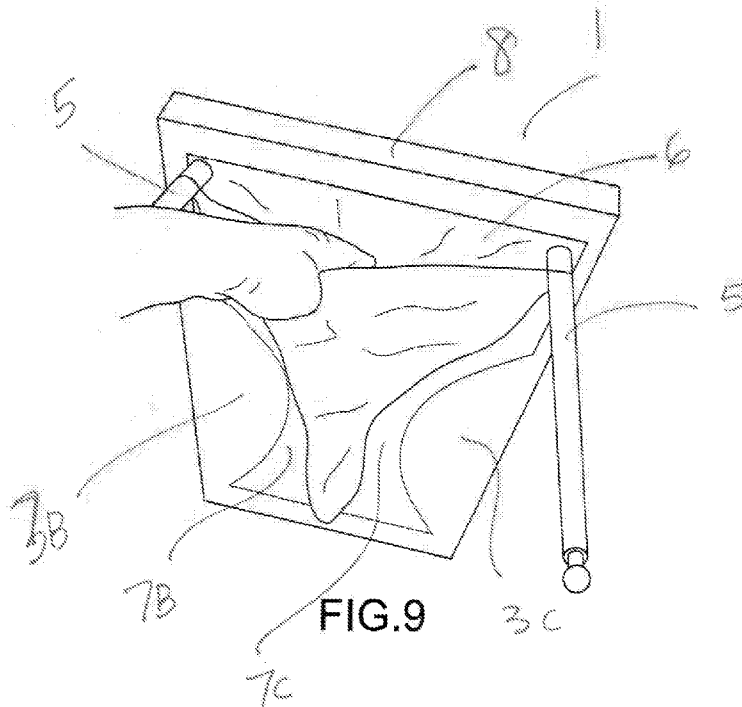

(57) Abstract: A bag apparatus for bags having a main body, front & rear panels, detachable sections that may be perforated and a flip section that provides a user access to the bags within the bag apparatus. The detachable sections, when detached, enable dispensing of bags from the apparatus. The bag apparatus also contemplates a number of mounting holes that align with the holes of bags and bars/rods or mounting structures of bag receptacles.

WO 2017/079028 A1

**Declarations under Rule 4.17:**

— *of inventorship (Rule 4.17(iv))*

**Published:**

— *with international search report (Art. 21(3))*

## **TRASH BAG APPARATUS**

### **CROSS-REFERENCE TO RELATED APPLICATIONS**

This Application claims the benefit of, and is related to, the following Applicant's  
5 provisional patent application: U.S. Provisional Patent Application No.  
62/251,159 titled "Trash Bag Apparatus" filed November 5, 2015, which is  
incorporated herein in its entirety.

### **FIELD OF THE INVENTION**

The present invention relates, in general, to a bag apparatus for the storage and  
10 dispensing of bags where the apparatus is structurally and functionally configured  
to be used in conjunction with bag receptacles that use bars/rods to mount and  
dispense bags.

### **BACKGROUND OF THE INVENTION**

Certain trash receptacles use specific structures such as bars/rods in order to  
15 dispense garbage bags. Current bag apparatus or containers for bags do not have  
the requisite structure and/or features needed to effectively dispense trash bags in  
conjunction with the trash receptacles that use bars/rods. Current bag containers  
also are not adequately structured to position bags in a ready to use position as  
they require a user to first remove the bag, open it and then place the bag in a  
20 secure ready to use position. As such, there exists a need for a trash bag apparatus  
or storage apparatus that can perform the functions required by trash receptacles  
with mounting bars/rods and trash receptacles that require trash bags with parallel  
holes punched or made in them. There also exists a need for a trash bag apparatus  
that ensures that the trash bags are in a ready position for immediate deployment  
25 once the apparatus is mounted onto trash bag receptacles that have mounting  
bars/rods.

### **SUMMARY OF THE INVENTION**

An aspect of an embodiment of the present invention contemplates a trash bag  
apparatus that may include a main body, the main body having two parallel holes

compatible for use with a trash receptacle that uses bars/rods/wire, or mounting structures to hang bags on (all meaning the same thing being interchangeable) to dispense trash bags. The trash bag apparatus or container may also include detachable, and/or perforated opening(s)/cutout(s) that enable a user to detach the cutout(s) or openings and gain access to the trash bags. The trash bag apparatus may also include a flip at the top of the container (which enables user access to the trash bags from the top), front and rear panels. The present invention is also able to be used with all types of receptacles and for other purposes with plastic bags such as packaging things or produce, to name a few. The apparatus described herein can be any sort of container that would hold the contents, including without limitations a box or other packaging device.

In an aspect of an embodiment of the present invention, a first detachable and/or perforated cutout/opening may be located on the trash bag apparatus's or container's front panel. In another aspect of an embodiment of the present invention, this cutout/opening may also have detachable and/or perforated sections around the parallel holes for the trash receptacle's bag mounting bars/rods to have access to enter in and pass through the apparatus.

In an aspect of an embodiment of the present invention, the trash bag apparatus may include a second detachable and/or perforated section located in the front panel that is larger than the first detachable section.

In an aspect of an embodiment of the present invention, the second detachable and/or perforated section may have two sides which may also be perforated and/or detachable in order to allow for a wider area to enable a user to easily detach a trash bag.

In an aspect of an embodiment of the present invention, the apparatus may include a large detachable and/or perforated section. The large detachable and/or perforated cutout/opening or section may be located on the trash bag apparatus's or container's front panel. In another aspect of an embodiment of the present invention, this large cutout/opening may also have perforated sections around the parallel holes for the trash receptacle's bag mounting bars/rods.

In an aspect of an embodiment of the present invention, the first detachable and/or perforated section may have two sides which may also be perforated and/or detachable in order to allow for a wider area to be open to enable a user to easily deploy a trash bag.

- 5 In an aspect of an embodiment of the present invention, the trash bag apparatus may include a large perforated section which may cover a large area of the front panel.

In an aspect of an embodiment of the present invention, the trash bag apparatus may include attachment mechanism(s) meant to attach or secure the apparatus to  
10 the trash bag receptacle.

Another aspect of an embodiment of the present invention contemplates an apparatus that is structurally and/or functionally configured to enable a user to safely transport the apparatus, load the apparatus on the mounting bars/rods, and use the apparatus having a large stack of bags without concern of the bags falling  
15 or becoming unusable if they become misaligned with the trash receptacle mounting bars/rods.

An aspect of an embodiment of the present invention contemplates a set of two strategically located parallel holes in the front and back of the apparatus that align front to back. Certain aspects of embodiments of the present invention  
20 contemplate a variety of shapes for these holes, including, without limitation, round holes, square holes etc. The holes are configured to be compatible with the trash receptacle bars/rods and the bag's hanging holes that are packaged inside of the apparatus.

In an aspect of an embodiment of the present invention, the apparatus may include  
25 an area that is open on the front and the back like a large rectangle or any shape that would allow the two parallel holes of the bag to be exposed from one large cutout/opening area of the bag apparatus. The area may be detachable and/or perforated or left open by the manufacturer. The open area on the front panel would allow the loading of the apparatus onto the bars/rods/wires of the receptacle

and also allow the bags to be dispensed through the same opening. Aspects of embodiments of the present invention contemplate either a large open section all in one or two parallel openings with an additional opening for the bags to exit the apparatus and ride along the bars/rods, in which case, either way the holes are  
5 accessible for loading onto the bars/rods.

In another aspect of an embodiment of the present invention, access for the receptacle bars/rods may be made by a hole or holes on the front and the back of the apparatus which may be perforated areas or structurally weakened areas that can be easily removed or enable the bars/rods to easily puncture or enter through  
10 the holes when a user is ready to hang the apparatus. In another aspect of an embodiment of the present invention, these bar/rod access area(s) of the apparatus may be removed by the apparatus manufacturer and sold open.

In another aspect of an embodiment of the present invention, the apparatus may be structurally and/or functionally configured to allow plastic bags to be loaded into  
15 the apparatus and adjusted so the bags' parallel punched holes end up exactly aligned with the hole(s) in the front and back of the apparatus.

A further aspect of an embodiment of the present invention contemplates a trash bag apparatus which may include front and rear panels, two parallel holes compatible for use with a trash receptacle that uses bars/rods to dispense trash  
20 bags, where the holes may extend through, and align with, both front and rear panels and mounting holes of the bags thereby enabling mounting of the apparatus and the bags within onto bars/rods of a bag receptacle. The bag apparatus may also include a detachable, slim section of the front panel, where the slim section enables a user to detach the slim section to deploy a bag from the apparatus, and a  
25 detachable top section at the top of the apparatus, where the top section, upon removal, enables user access to the hanging holes of the bags.

In a further aspect of an embodiment of the present invention, the bag apparatus may also include a detachable medium section that is larger than the slim detachable section of the front panel, where the medium section enables faster bag  
30 deployment from the apparatus than the slim section did.

In a further aspect of an embodiment of the present invention, the bag apparatus may also include a detachable large section that is bigger than the medium section of the front panel, where the large section enables even faster bag deployment from the apparatus than the medium section would allow.

- 5 In a further aspect of an embodiment of the present invention, the detachable top section may include both detachable and non-detachable sections, where the non-detachable section enables the apparatus to remain mounted on the bars/rods (of the receptacle) after the detachable section of the top section has been detached. In another aspect of an embodiment of the present invention, the non-detachable  
10 section may be located at the rear of the top section.

In an aspect of an embodiment of the present invention, the single large section or parallel holes/openings may be located on the bag apparatus in the front and back and in an area towards the top of the bag apparatus. This configuration or  
15 positioning will allow access by hanging bars/rods of a receptacle which may then be able to enter the rear hole(s) of the bag apparatus then at the same time enter into the bag's hanging holes that are inside the bag apparatus and then pass through the front opening of the bag apparatus so the bars/rods pass through and remain inside the bags and the bag apparatus all at once.

In an aspect of an embodiment of the present invention, the bag apparatus may be  
20 structurally and/or functionally configured to allow bags to be in a position that works with a two parallel bar/rod/wire receptacle system. The bag apparatus may also be structurally and/or functionally configured to enable bags to be upright, with the open bag mouth on top, the closed area at the bottom and be stacked in an order where the back of the first bag signals or effects the front of the second bag  
25 to open when the first is removed from the bag apparatus although any type of bag may be used with this bag apparatus.

In another aspect of an embodiment of the present invention, the bag apparatus may be firm enough to keep the bags tight and orderly. Use of strong cardboard material, for instance, may suffice. Plastic material may also be used. However,  
30 these examples are not limiting as other strong materials may be used in order to

meet the demands of the apparatus as disclosed in this application. Aspects of embodiments of the present invention also contemplate the bag apparatus being made of different material.

5 In another aspect of an embodiment of the present invention, the bag apparatus may be structurally and/or functionally configured to exert enough force on the stack of trash bags so that only one bag is removed at a time. This saves money for the user as there will be fewer wasted bags and less frustration for the user.

10 Another aspect of an embodiment of the present invention contemplates a trash bag apparatus that is free hanging so the bottom of the apparatus is not touching the base of the trash receptacle or the floor so that the trash bag apparatus remains clean to protect the trash bags inside the trash bag apparatus from being soiled if a used bag leaks.

15 Another aspect of an embodiment of the present invention contemplates a trash bag apparatus with the ability to be enclosed during shipment, storing, sales, etc. so the trash bags within it remain protected, clean and orderly.

20 Another aspect of an embodiment of the present invention contemplates a trash bag apparatus with one or more openings in the front and one or more openings on the back towards the top area of the apparatus that allows the user to see the parallel holes of the bags through those openings on the apparatus in order to place the rods/bars through one side of the apparatus into the holes of the bags and out the other side of the apparatus in order to load the entire apparatus with bags inside of it onto the rods/bars. The opening(s) in the top area of the front and back panels of the apparatus can be left open by the manufacturer on purpose or made to be purposely removed by the manufacturer or the user at some point.

25 The trash bag apparatus may have a number of precut, outlined, adhesively stuck on, or weakened areas that may be removable by perforation, tearing, peeling or cutting or any other means in the front panel of the apparatus from which the bags will be dispensed from.



The trash bag apparatus may have one or more openings in the front of the apparatus where the bags can exit while still hanging on the bars/rods from inside the apparatus and move along the bars/rods into the ready to use position so they can collect trash while still hanging. The one or more openings that are in the front panel of the apparatus for the bags to exit the apparatus through can be left open 5 completely or partially on purpose by the manufacturer or designed to be removed by the manufacturer or user. If the front panel opening is designed to stay open any type of material can be used to keep the bags inside until ready to use such as a sticker that peels off etc.

10 An aspect of an embodiment of the present invention contemplates the trash bag apparatus being enabled structurally to allow rear parallel holes or one larger open section to access the bags hanging holes. The parallel holes may remain so that the trash bag apparatus may be hung and support the interior bags. However, the front holes of the trash bag apparatus will end up being removed with sections of the 15 front panel so the bag will not be prevented from exiting the apparatus and can freely move along the rods while exiting the trash bag apparatus when needed.

Aspects of embodiments of the present invention contemplate the trash bag apparatus can have a few options of different shapes and sizes of front panel cut out/open areas so the user can decide how easy and speedily they would like to 20 adjust the bag removal quality.

Aspects of embodiments of the present invention contemplate the trash bag apparatus having already one or more open or precut or optionally removable sections on the back panel of the apparatus similar to those on the front panel in case the apparatus is loaded backwards and so the user does not have to remove 25 and reload it in the correct direction.

In a further aspect of an embodiment of the present invention the trash bag apparatus may include a detachable top section which covers the holes in the bags and when detached will allow the top section of the bags where the hanging holes are to completely be exposed and easily loaded onto the receptacle mounting 30 bars/rods/wires.

In a further aspect of an embodiment of the present invention the trash bag apparatus may include a top section that keeps the middle and bottom sections so that the bags are still kept orderly.

5 The trash bag apparatus may have areas of the front panel material remaining in place after an open access area in the front panel has been made to dispense bags out of. The trash bag apparatus may also be structurally and/or functionally configured to allow pressure from the remaining front panel sections/areas to be applied to the interior bag stack so that the bags do not inconveniently come out of the apparatus through the open access area in the front panel that was made for  
10 dispensing bags.

Aspects of embodiment of the present invention contemplate attachment or securing mechanism(s) that enable the trash bag apparatus to be secured into place at the rear area of the bars/rods so it cannot easily move. Exemplary, but not limiting, examples of such attachment mechanism(s), include adhesives on the  
15 back of the trash bag apparatus or the receptacle, hook and loop, interlocking, hanging, hooks, clipping mechanisms (that clip the apparatus into position or engage into position with the receptacle itself or a part of the receptacle). The trash bag apparatus can connect on to the rod/bar system, the rear receptacle area, the rear cross bar, etc. depending on which two bar/rod/wire style of receptacle the  
20 user is using.

A further aspect of an embodiment of the present invention contemplates the trash bag apparatus being structurally and functionally configured to allow the last bag of the stack to be releasably secured to the inside of the back panel of the apparatus so that when the user is approaching the last few bags they do not fall  
25 out of the apparatus as a result of the bag not being secured or held back by pressure.

A further aspect of an embodiment of the present invention contemplates the trash bag apparatus maintaining the interior bag stacks hanging hole alignment by any number of methods, systems, etc.

A further aspect of an embodiment of the present invention contemplates the trash bag apparatus having a corking arrangement for the bag holes before being loaded for use while they are still in the apparatus.

5 A further aspect of an embodiment of the present invention contemplates the trash bag apparatus having a tying arrangement through the holes until use of the bags. The trash bag holes may stay in place simply from intense direct pressure from the trash bag apparatus itself. Any type of material or construction of the apparatus can be used to keep the bag hanging holes aligned and ready for mounting.

10 The bag apparatus allows for the smooth transition for a bag to go from folded, hanging, supported and protected while inside the apparatus to then be deployed from the apparatus for use while still hanging in a fully supported position by the bars/rods of the receptacle.

15 Additional aspects, objectives, features and advantages of the present invention will become apparent from the following description of the preferred embodiments with reference to the attached drawings.

### **BRIEF DESCRIPTION OF THE DRAWINGS**

FIG. 1 illustrates a view showing a bag apparatus and parallel holes which enable mounting of the bag apparatus onto a trash receptacle according to an aspect of an embodiment of the present invention.

20 FIG. 2 illustrates a view showing a bag apparatus and a detachable and/or perforated section on a front panel of the bag apparatus according to an aspect of an embodiment of the present invention.

FIG. 3 illustrates a view showing a bag apparatus having been mounted onto the bars/rods of a receptacle according to an aspect of an embodiment of the present invention.  
25

FIG. 4 illustrates a view showing trash bags with their holes in conjunction with a trash bag apparatus according to an aspect of an embodiment of the present invention.

FIG. 5 illustrates a view showing a detailed view of an outer circle that represents the hole in a bag apparatus that aligns with an inner circle which represents the hanging holes of the bags that are inside of the apparatus so the hanging rods/bars of a receptacle can enter through both the apparatus hole and bags holes simultaneously according to an aspect of an embodiment of the present invention.

FIG. 6 illustrates a view showing a user beginning to remove a detachable and/or perforated section of a trash bag apparatus according to an aspect of an embodiment of the present invention.

FIG. 7 illustrates a view showing a user continuing to remove a detachable and/or perforated section of a trash bag apparatus according to an aspect of an embodiment of the present invention.

FIG. 8 illustrates a view showing a user further removing a detachable and/or perforated section of a trash bag apparatus according to an aspect of an embodiment of the present invention.

FIG. 9 illustrates a view showing a user dispensing a trash bag from a trash bag apparatus, the user having removed a detachable and/or perforated section of the trash bag apparatus according to an aspect of an embodiment of the present invention.

FIG. 10 illustrates a view showing a user beginning to remove additional sections of a detachable and/or perforated section of a trash bag apparatus according to an aspect of an embodiment of the present invention.

FIG. 11 illustrates a view showing a user continuing to remove additional sections of a detachable and/or perforated section of a trash bag apparatus according to an aspect of an embodiment of the present invention.

FIG. 12 illustrates a view showing a user further removing additional sections of a detachable and/or perforated section of a trash bag apparatus according to an aspect of an embodiment of the present invention.

FIG. 13 illustrates a view showing a trash bag apparatus with an open section and mounted on a trash bag receptacle according to an aspect of an embodiment of the present invention.

FIG. 14 illustrates a view showing a trash bag apparatus mounted on a trash bag receptacle with a dispensed trash bag according to an aspect of an embodiment of the present invention.

FIG. 15 illustrates a view showing a trash bag apparatus mounted on a trash bag receptacle showing a removable/detachable top section of the trash bag apparatus according to an aspect of an embodiment of the present invention.

FIG. 16 illustrates a view showing a trash bag apparatus mounted on a trash bag receptacle showing its removable/detachable top section being removed/ detached according to an aspect of an embodiment of the present invention.

FIG. 17 illustrates a view showing a trash bag apparatus mounted on a trash bag receptacle showing its removable/detachable top section having been fully removed/ detached according to an aspect of an embodiment of the present invention.

FIGs. 18 & 19 illustrate views showing a trash bag mounted on a trash bag receptacle and being distanced or removed from inside a trash bag apparatus according to aspects of embodiments of the present invention.

FIG. 20 illustrates a view showing a trash bag mounted on a trash bag receptacle without a trash bag apparatus according to an aspect of an embodiment of the present invention.

FIG. 21 illustrates a view showing a trash bag apparatus with attachment mechanism(s) according to an aspect of an embodiment of the present invention.

FIG. 22 illustrates a view showing a trash bag apparatus mounted on a trash bag receptacle showing its removable/detachable front section having been fully removed/ detached according to an aspect of an embodiment of the present invention.

FIG. 23 illustrates a view showing a user about to dispense a trash bag from a trash bag apparatus mounted on a trash bag receptacle according to an aspect of an embodiment of the present invention.

FIG. 24 illustrates a view showing a user dispensing a trash bag from a trash bag apparatus mounted on a trash bag receptacle according to an aspect of an embodiment of the present invention.

FIG. 25 illustrates a view showing a user removing a full trash bag from a trash bag receptacle according to an aspect of an embodiment of the present invention.

FIGS. 26-28 illustrate views showing removed trash bags next to a trash bag receptacle and a mounted trash bag apparatus according to aspects of embodiments of the present invention.

### **DETAILED DESCRIPTION OF THE INVENTION**

Referring now to FIGS. 1-5, views showing trash bag apparatus 1, its parallel holes 2A & 2B, front panel 3 of trash bag apparatus 1, trash bag apparatus 1's mounting onto trash receptacle bars/rods 5, and a detailed view of holes 2A, 2B of a trash bag apparatus are shown according to aspect(s) of embodiment(s) of the present invention.

Trash bag apparatus 1 is shown having parallel holes 2A and 2B on front panel 3 and holes 2C and 2D on rear panel 4 (not shown) which are configured to be mounted onto a trash receptacle having bars/rods 5. Holes 2A-D of apparatus 1 are aligned from front to rear and extend from front panel 3 to back panel 4 of apparatus 1 and provide access while mounting on the trash receptacle rods/bars through the rear panel 4 into the interior product space of trash bag apparatus 1 and also through front panel 3. In an aspect of an embodiment of the present invention, front panel 3 may include one or more removable and/or perforated sections or cutouts 3A through 3C. In one aspect of an embodiment of the present invention, sections 3B and 3C may be semi-circular in shape and may be positioned on either side of outer detachable cutout 3A. In application, holes 2A - 2B enable installation of bag apparatus 1 containing bag(s) 6 onto receptacle

bars/rods 5. This may be made possible by holes 6A and 6B on bag(s) 6 which align with holes 2A-D of apparatus 1 which enable bars/rods 5 to enter through holes 2A-D, and holes 6A & 6B.

Parallel holes 2A-D of bag apparatus 1 may be multi-purpose in function to perform, *inter alia*, the following functions:

1. Enabling the loading of bag apparatus 1 onto rod(s) or bar(s) 5 of receptacle 11 thereby hanging bag apparatus 1 for use;
2. Keeping the holes in bag(s) 6 in positioned alignment; and
3. Allowing bag(s) 6 to deploy from inside bag apparatus 1 directly into the ready to use position while keeping alignment with receptacle bar(s)/rod(s) 5.

In an aspect of an embodiment of the present invention, front panel 3 may include first and second removable or detachable sections where the second section may be larger than the first section and where both sections enable a user to remove or detach either section to gain access to the trash bags.

In another aspect of an embodiment of the present invention, front panel 3 may include opening(s) compatible for use with a receptacle that uses bars or rods 5 to dispense bags 6, where the openings extend through and align with both front (3) and rear (4) panels with mounting holes 2A-D and mounting holes 6A and 6B of bags 6 thereby enabling mounting of apparatus 1 and bags 6 onto bars or rods 5. Front panel 3 may also have opening(s) where the opening(s) enables a user to deploy trash bag 6 from apparatus 1. In one aspect, the opening(s) in front panel 3 for bag deployment may be manufactured to remain open. In another aspect, the opening(s) in front panel 3 may be temporarily closed and ready to open by being removed or detached when ready to use. In yet another aspect, the opening(s) in front panel 3 for bag deployment may be temporarily covered or closed by any material until ready to use.

Referring now to FIGs. 6-9 views showing a user progressively removing or detaching inner removable and/or perforated section 7 of apparatus 1 are shown

according to aspect(s) of embodiment(s) of the present invention. Inner removable and/or perforated cutout or section 7 may be exposed with the removal of outer removable or detachable cutout 3A. In one aspect of an embodiment of the present invention, section 7 may have three sections 7A-C with section 7A being located  
5 in the middle and sections 7B & 7C being located to the respective sides of section 7A. In one aspect of an embodiment of the present invention, section 7A may include a slim or first section which enables a tighter hold for slower bag deployment as shown in FIG. 9 with the slow deployment of bag 6 through the slim section of cutout 7A.

10 Referring now to FIGs. 10-12 views showing a user removing or detaching additional or second sections 7B & 7C of inner removable and/or perforated section 7 of trash bag apparatus 1 are shown according to aspect(s) of embodiment(s) of the present invention. Removal of sections 7B & 7C enable faster and easier deployment of bag 6 from apparatus 1.

15 In a further aspect of an embodiment of the present invention, trash bag apparatus 1 may include a removable or detachable medium section located on the front panel 3, where the medium section enables faster trash bag 6 deployment from apparatus 1. In a yet further aspect of an embodiment of the present invention, trash bag apparatus 1 may also include a removable or detachable large or third  
20 section located on the front panel that is larger than the medium section, where the large section may enable even faster trash bag 6 deployment from apparatus 1.

Referring now to FIGs. 13 and 14 views showing a mounted trash bag apparatus 1 having an open section 9 and a deployment view of bag 6 from apparatus 1 through open section 9 are shown according to aspect(s) of embodiment(s) of the  
25 present invention. In one aspect of an embodiment of the present invention, apparatus 1 may have one large removable and/or perforated front panel 3, which, upon removal provides open section 9 for faster and full deployment of bag 6 from apparatus 1 as shown in FIG. 14.

Referring now to FIGs. 15-17 views showing removable or detachable top section  
30 8 of trash bag apparatus 1 are shown according to aspect(s) of embodiment(s) of



the present invention. Apparatus 1 may have top removable, detachable and/or perforated section 8 which enables access to holes 2A-D directly. Access to bag(s) 6 may also be enabled by removal of detachable top section 8. In one aspect of an embodiment of the present invention, section 8 may be connected with a removable or detachable front panel 3 which may enable access to deploy bag(s) 6. In another aspect of an embodiment of the present invention, apparatus 1 may have just have one opening in total in the front of apparatus 1 which allows access to both holes 6A & 6B of bag(s) 6 in order to hang and provide access to bag(s) 6 in which case, bag(s) 6 may be able to be deployed faster and easier from apparatus 1 with the user having removed an entire large section of the apparatus all at one time which will allow someone access to the holes and to deploy the bags all at once by simply removing one section only. This large piece can be removed by the manufacturer or the user when ready to use.

In one aspect of an embodiment of the present invention, removable or detachable top section 8 may include of detachable and non-detachable sections, where the non-detachable section enables the apparatus to remain mounted on the bars/rods after the detachable section of top section 8 has been detached.

Referring now to FIGs. 18-20, views showing removal of detachable top section 8 & the remaining section of apparatus 1 are shown according to aspect(s) of embodiment(s) of the present invention. With the removal of detachable top section 8, a user can still keep the remaining section of apparatus 1 to retain control of bag flow from apparatus 1. In another aspect of an embodiment of the present invention, the remaining section of apparatus 1 may be removed for full bag exposure as shown in FIGs. 18-20 thereby resulting in full exposure of bag(s) 6 as shown in FIG. 20.

Referring now to FIG. 21, a view showing trash bag apparatus 1 with attachment mechanism(s) 10 is shown according to an aspect of an embodiment of the present invention. Attachment mechanism(s) 10 of apparatus 1 may be configured to connect and secure to trash receptacle 11 to ensure apparatus 1 remains in position. Attachment mechanism(s) 10 may be, without limitation, any one of:

hook and loop, hook, adhesive, lock, clips. Attachment mechanism(s) 10, in another aspect of an embodiment of the present invention, may cooperatively lock with corresponding mechanism(s) 12 on trash receptacle 11 in order to secure apparatus 1 in position.

5 Referring now to FIG. 22, a view showing trash bag apparatus 1 mounted on trash bag receptacle 11 showing removable or detachable front section 3A having been fully detached is shown according to an aspect of an embodiment of the present invention. In one aspect of an embodiment of the present invention, apparatus 1, by its installation on bars/rods 5 of a trash receptacle, may not touch the base of  
10 trash receptacle 11 as it would hang above the base of trash receptacle 11 thereby avoiding contact with potential spills etc. that may occur.

Referring now to FIGs. 23-28, views showing progressional deployment of bag 6 from apparatus 1 are shown according to aspect(s) of embodiment(s) of the present invention. Apparatus 1, having been mounted onto bars/rods 5 of trash  
15 receptacle 11, enable deployment of bag 6 through removed/detached section 3a of apparatus 1. This configuration enables deployment of bag 6 as shown and subsequent deployment of the next bag from apparatus 1. Apparatus 1, by way of its installation and use of its removable and/or perforated portions, enable release of only one bag 6 as a used bag is pulled away (FIGs. 26-28).

20 The invention has been described in detail with particular reference to certain preferred embodiments thereof, but it will be understood that variations and modifications can be effected within the spirit and scope of the invention.

## CLAIMS

What is claimed is:

1. A bag apparatus comprising:
  - a main body, the main body having a plurality of holes compatible for use with a receptacle that uses bars or rods to dispense bags;
  - front and rear panels; and
  - a first detachable section, wherein the section enables a user to detach the section and gain access to the bags.
2. The bag apparatus of claim 1, where the at least at least two of the plurality of holes are parallel to each other.
3. The bag apparatus of claim 1, wherein the apparatus may have a flip structure at the top of the apparatus for the user to access the bags from the top of the apparatus.
4. The bag apparatus of claim 1, wherein the first detachable section may be located on the bag apparatus's front panel.
5. The bag apparatus of claim 2 wherein the detachable section may also have removable areas around the parallel holes for the receptacle's bag mounting bars or rods.
6. The bag apparatus of claim 1, further comprising a second detachable section located in the front panel but larger than the first detachable section.
7. The bag apparatus of claim 6 wherein the second detachable section may have 2 sides which may also be detachable in order to allow for a wider area to enable a user to easily deploy a bag.

8. The bag apparatus of claim 1, further comprising a large removable section which may cover a large area of the front panel.
9. The bag apparatus of claim 1, further comprising one or more attachment mechanisms meant to attach or secure the apparatus to the bag receptacle.
10. The bag apparatus of claim 1, wherein the plurality of holes includes at least two parallel holes in the front and back of the apparatus that align front to back.
11. The bag apparatus of claim 10 wherein the plurality of holes may have any one or more of the following shapes: round, square, or shapes that are configured to be compatible with the receptacle bars or rods.
12. The bag apparatus of claim 10, further comprising a large section that is open on the front and the back of the apparatus, wherein two parallel holes in the bag are accessible through the opening created by the large section of the bag apparatus.
13. The bag apparatus of claim 12, wherein the large area may be detachable.
14. The bag apparatus of claim 1, wherein at least two of the plurality of the holes are covered or are structurally weakened so that they can be removed or pierced by receptacle bars or rods when the main body is mounted on such receptacle bars or rods.
15. The bag apparatus of claim 1, wherein at least two of plurality of the holes are open to receive receptacle bars or rods when the main body is mounted on such receptacle bars or rods.

16. The bag apparatus of claim 2, wherein the apparatus is structurally and/or functionally configured to allow plastic bags to be loaded into the apparatus so that holes in the plastic bags are substantially aligned with the holes in the front and back of the apparatus.
17. The bag apparatus of claim 1, wherein the bags are trash bags.
18. A bag apparatus comprising:
  - front and rear panels;
  - at least two holes compatible for use with a receptacle that uses bars or rods to dispense bags, wherein the holes extend through and align with both front and rear panels and mounting holes in the bags thereby enabling mounting of the apparatus and the bags onto bars or rods of a bag receptacle; and
  - a first detachable section of the front panel, wherein the section may be detached to deploy a bag from the apparatus.
19. The bag apparatus of claim 18, where the at least two holes are parallel to each other.
20. The bag apparatus of claim 18, further comprising a second detachable section larger than the first detachable section.
21. The bag apparatus of claim 20, further comprising a third detachable section that is larger than the second detachable section.
22. The bag apparatus of claim 18, further comprising a top section including both a detachable and non-detachable section, wherein the non-detachable section enables the apparatus to remain mounted on the bars or rods after the detachable section of the top section has been detached.

23. The bag apparatus of claim 18, wherein the bags are trash bags.
24. A bag apparatus comprising:  
front and rear panels;  
  
at least one opening in the front and rear panels compatible for use with a receptacle that uses bars or rods to dispense bags, wherein the at least one openings in the front and rear panels are aligned with each other and with the mounting holes in the bags thereby enabling mounting of the apparatus and the bags onto bars or rods of a bag receptacle; and  
  
an additional opening on the front panel, wherein the additional opening enables a user to deploy a bag from the apparatus.
25. The bag apparatus of claim 24, wherein the additional opening in the front panel is covered by a section that may be detached, moved or otherwise displaced.
26. The bag apparatus of claim 24, wherein the opening(s) in the front panel for bag deployment may be temporarily covered or closed by any material until the apparatus is ready to use.
27. The bag apparatus of claim 24, wherein the additional opening on the front panel and the at least one opening on the front panel comprise a single opening.
28. The bag apparatus of claim 24, wherein the bags are trash bags.
29. A bag apparatus comprising:  
a main body, the main body having a plurality of holes compatible for use with a receptacle that uses bars or rods to dispense bags;

front and rear panels; and

a detachable section, wherein the section is detachable to gain access to the bags.

30. The bag apparatus of claim 29, wherein at least two of the plurality of holes are parallel to each other.

31. The bag apparatus of claim 29, wherein the detachable section consists of a detachable first section and a detachable second section which are both detachable.

32. The bag apparatus of claim 29, wherein the bags are trash bags.

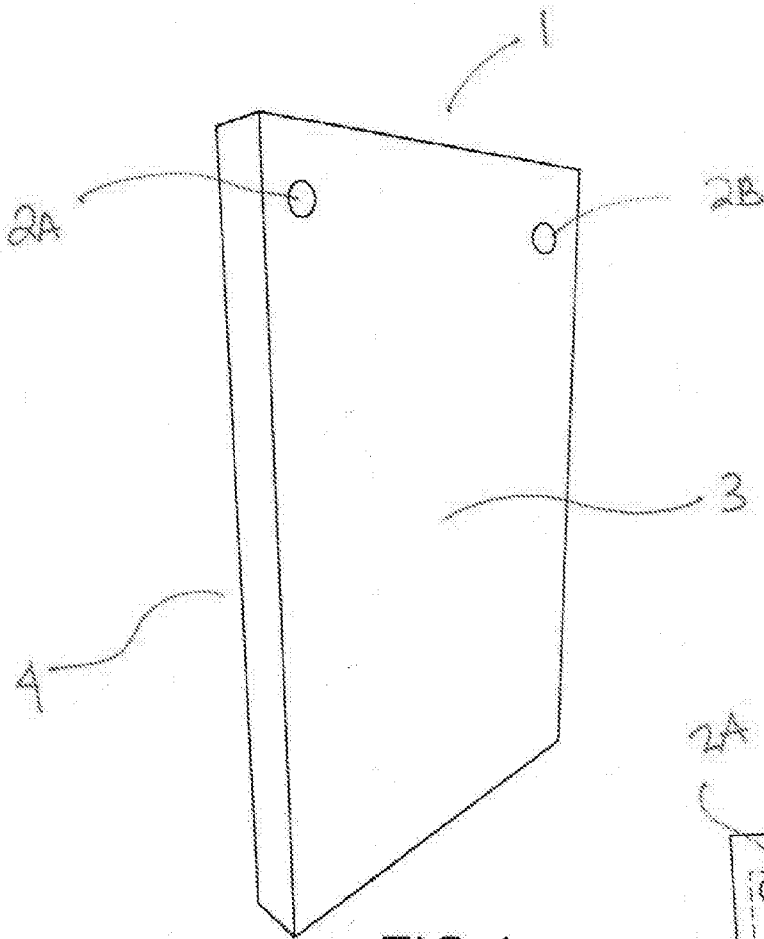

FIG. 1

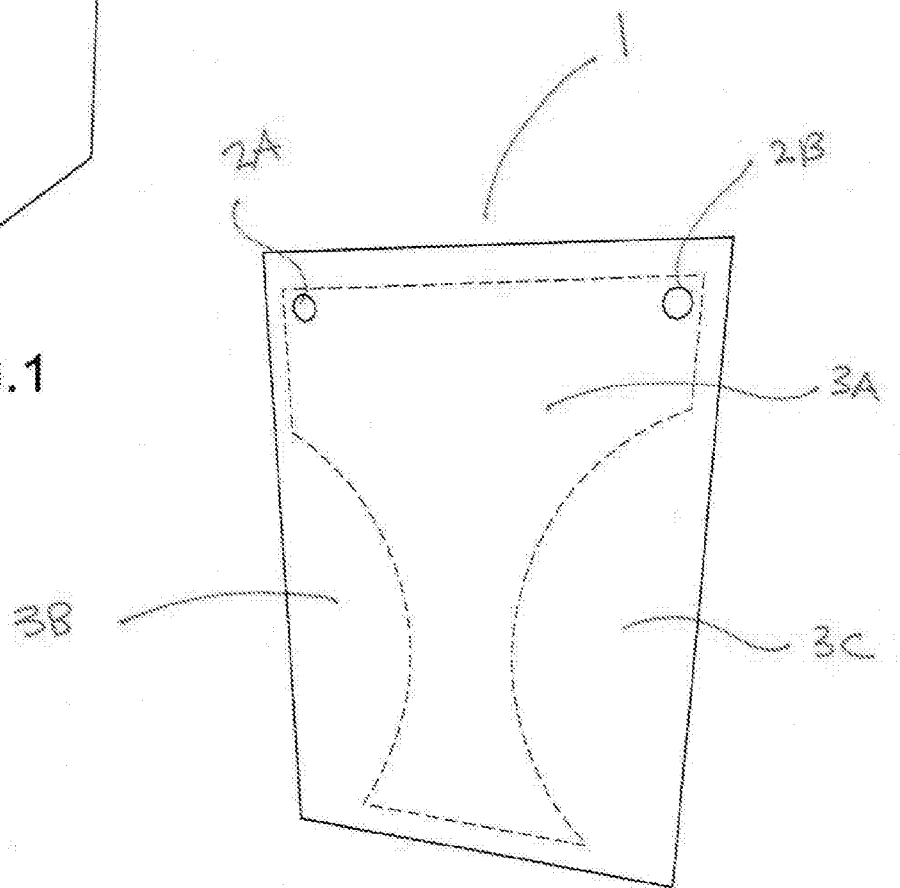
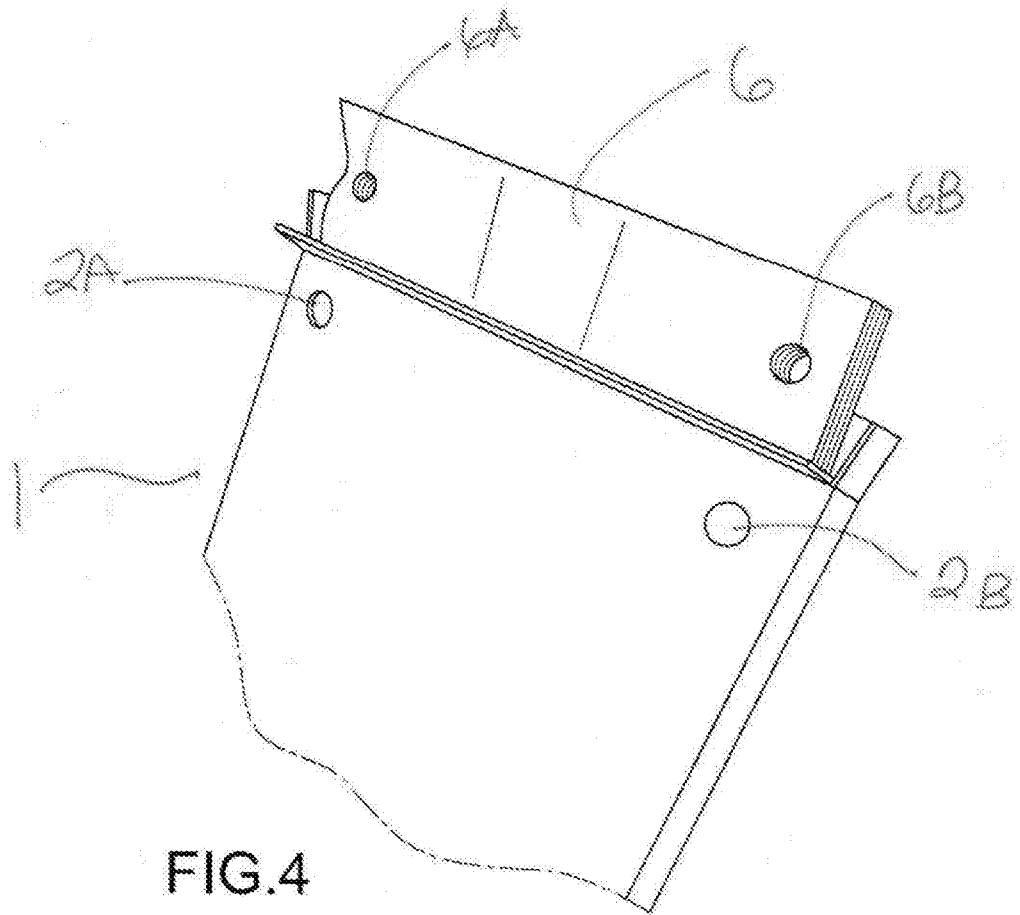
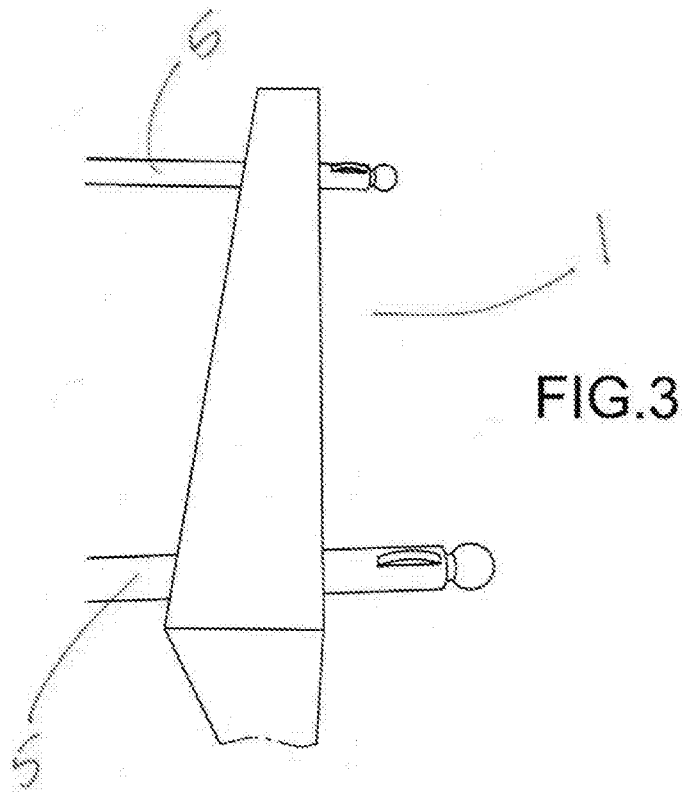

FIG. 2





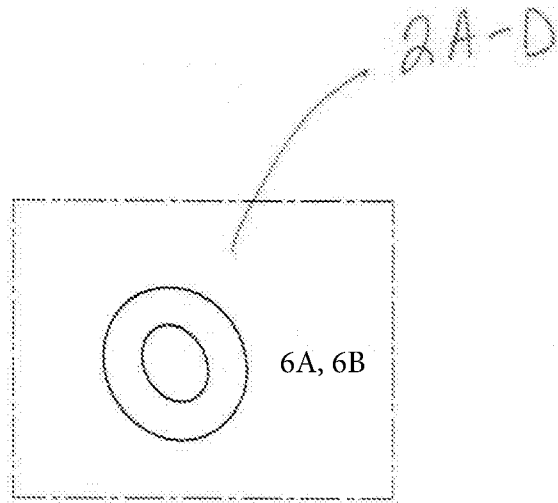

FIG. 5

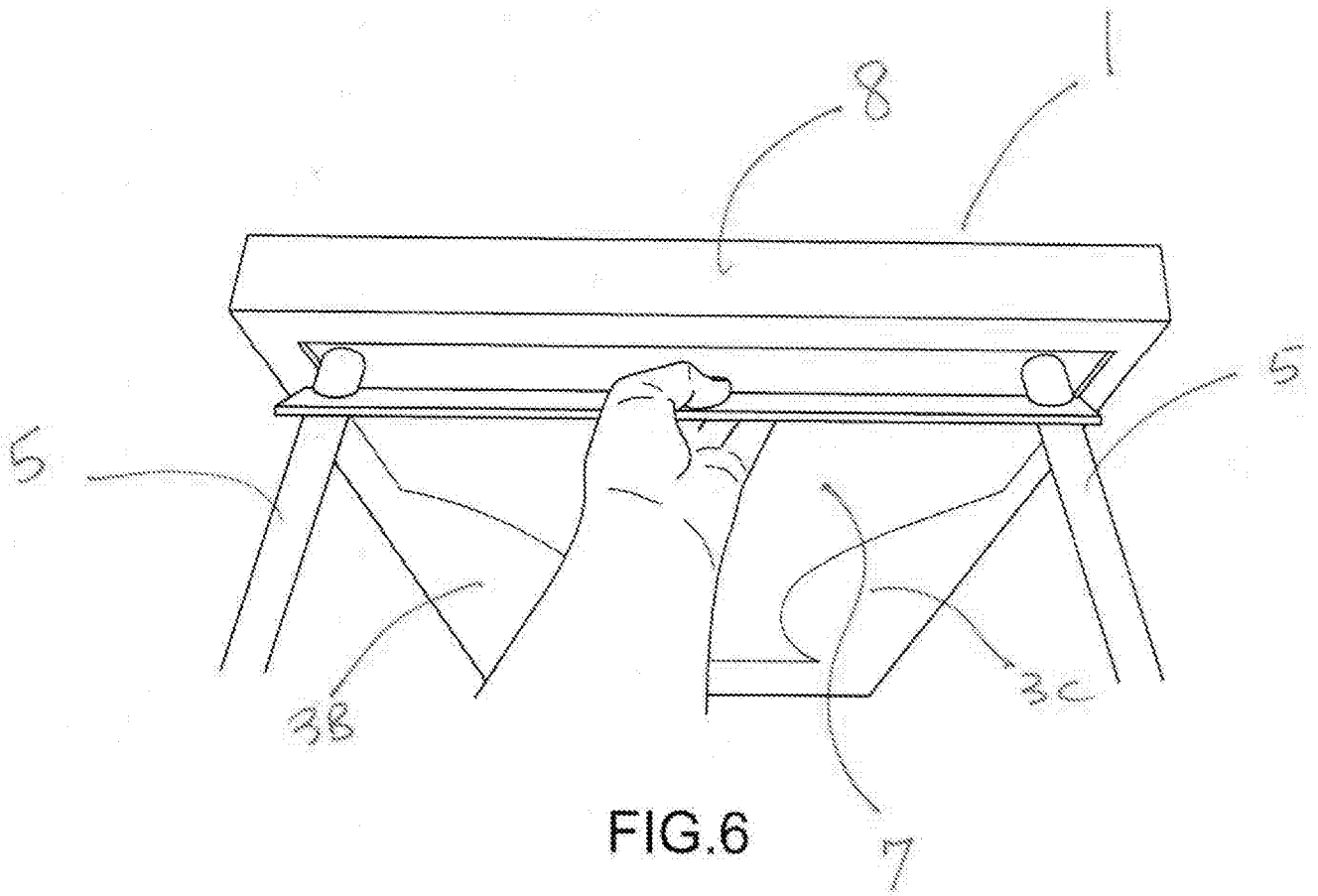
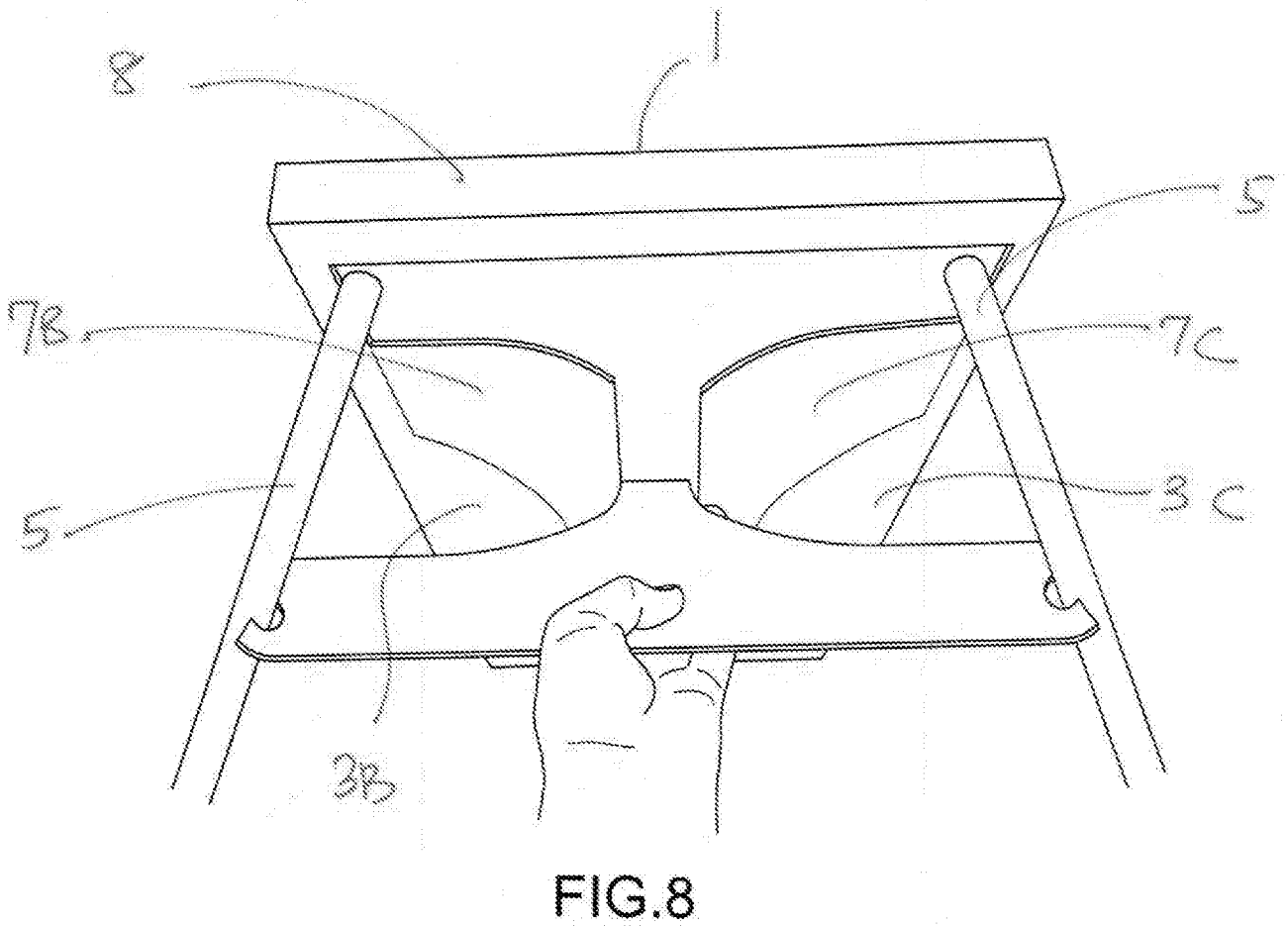
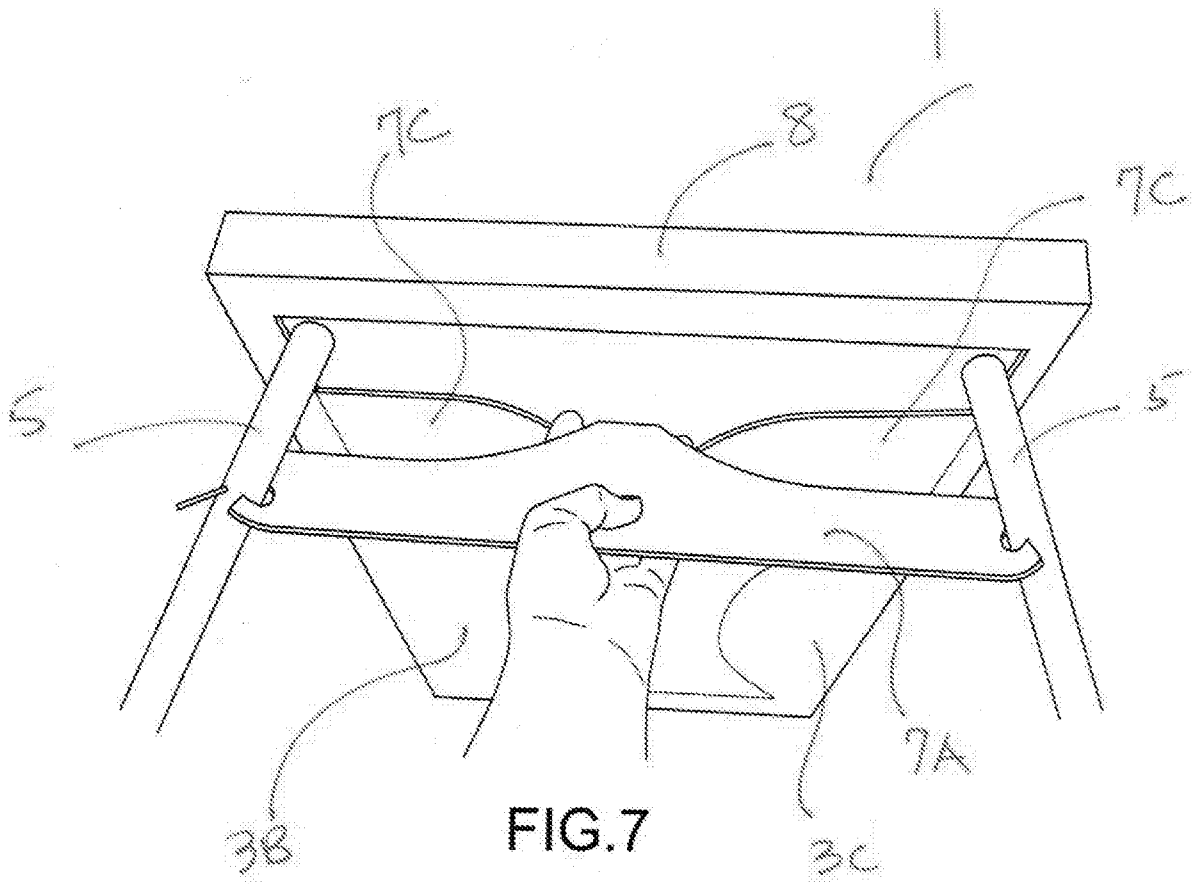

FIG. 6



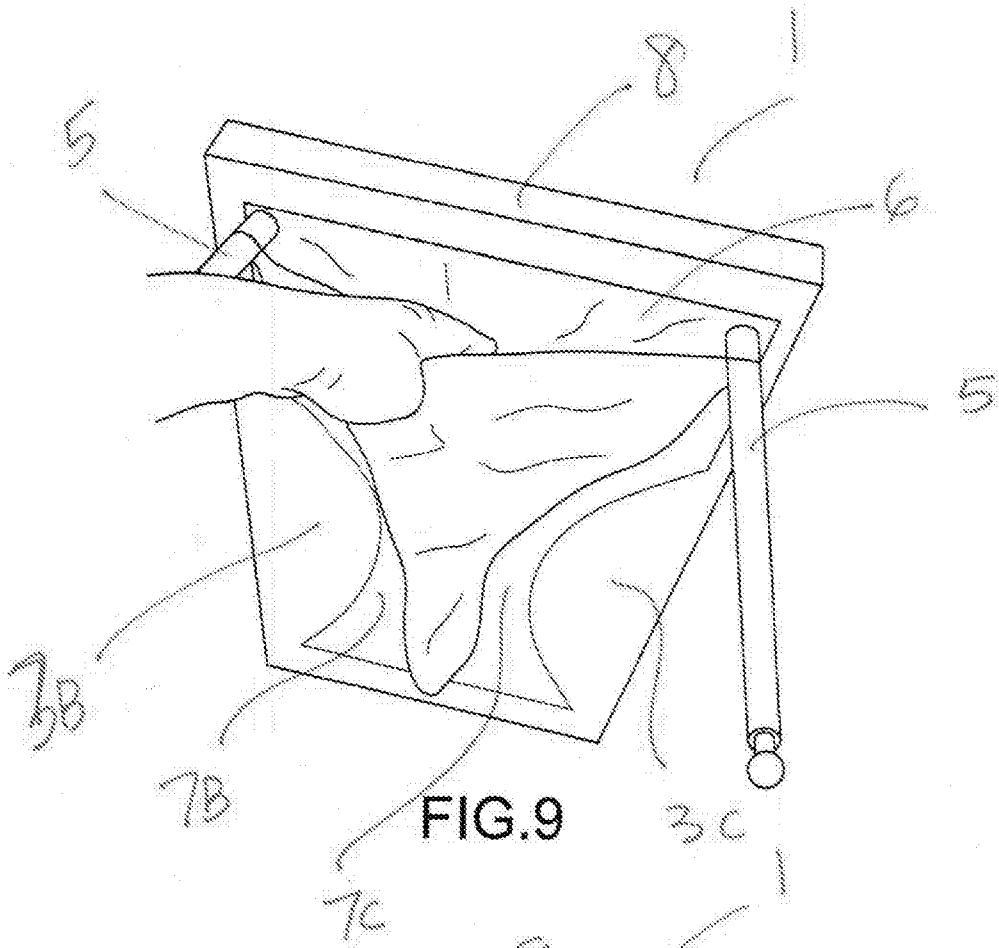

FIG. 9

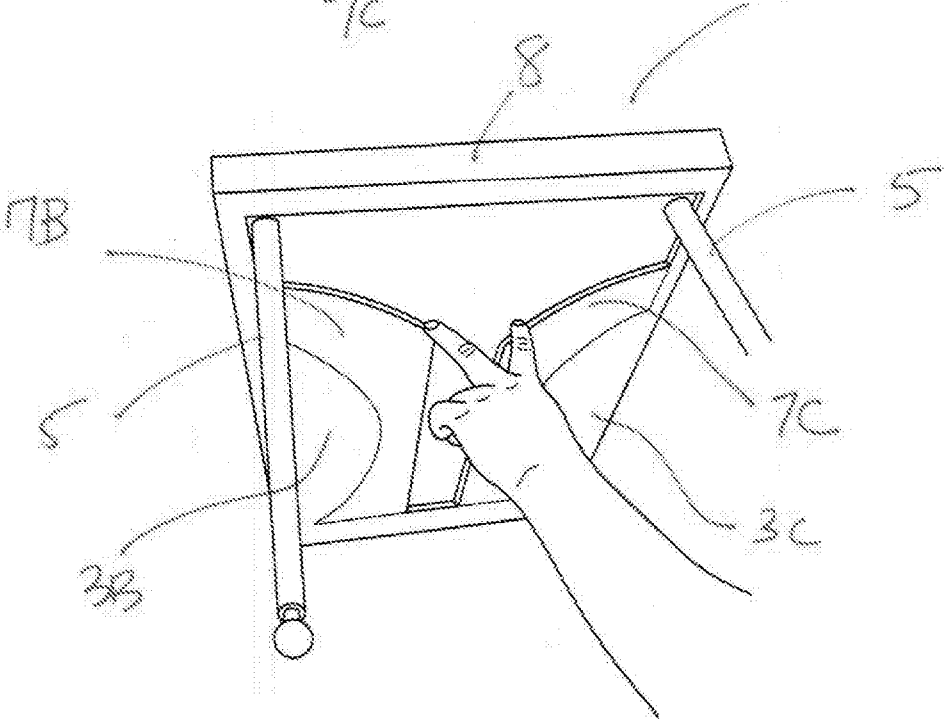
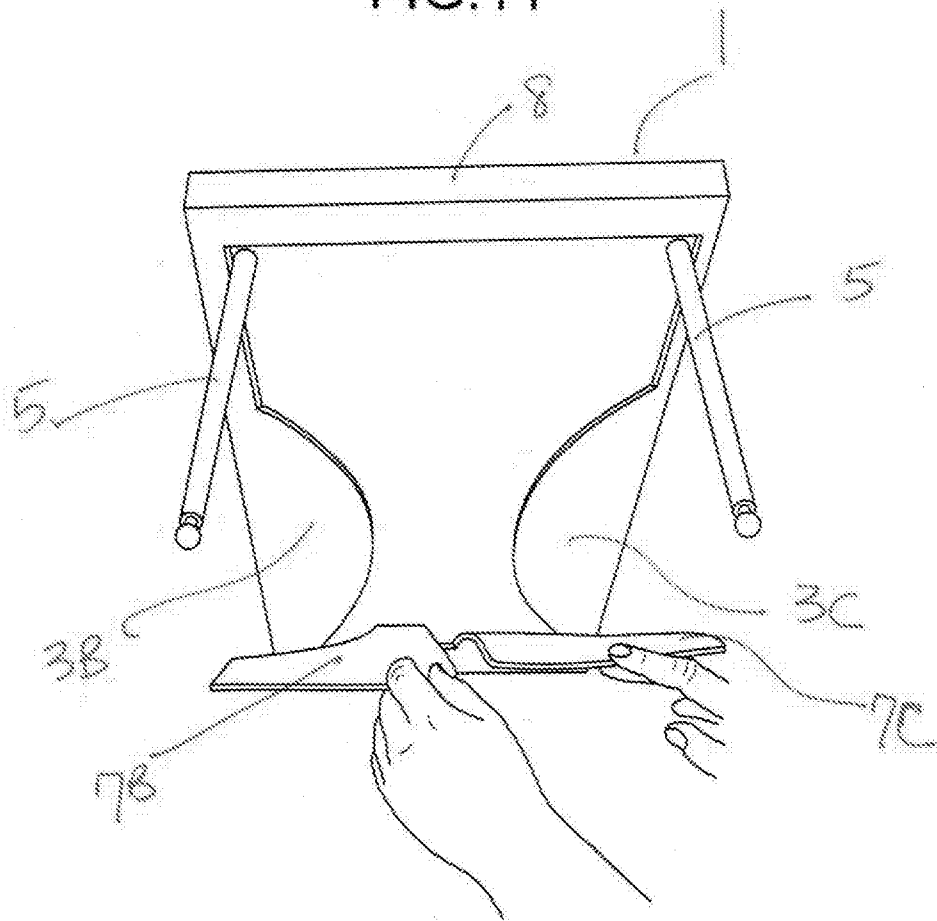
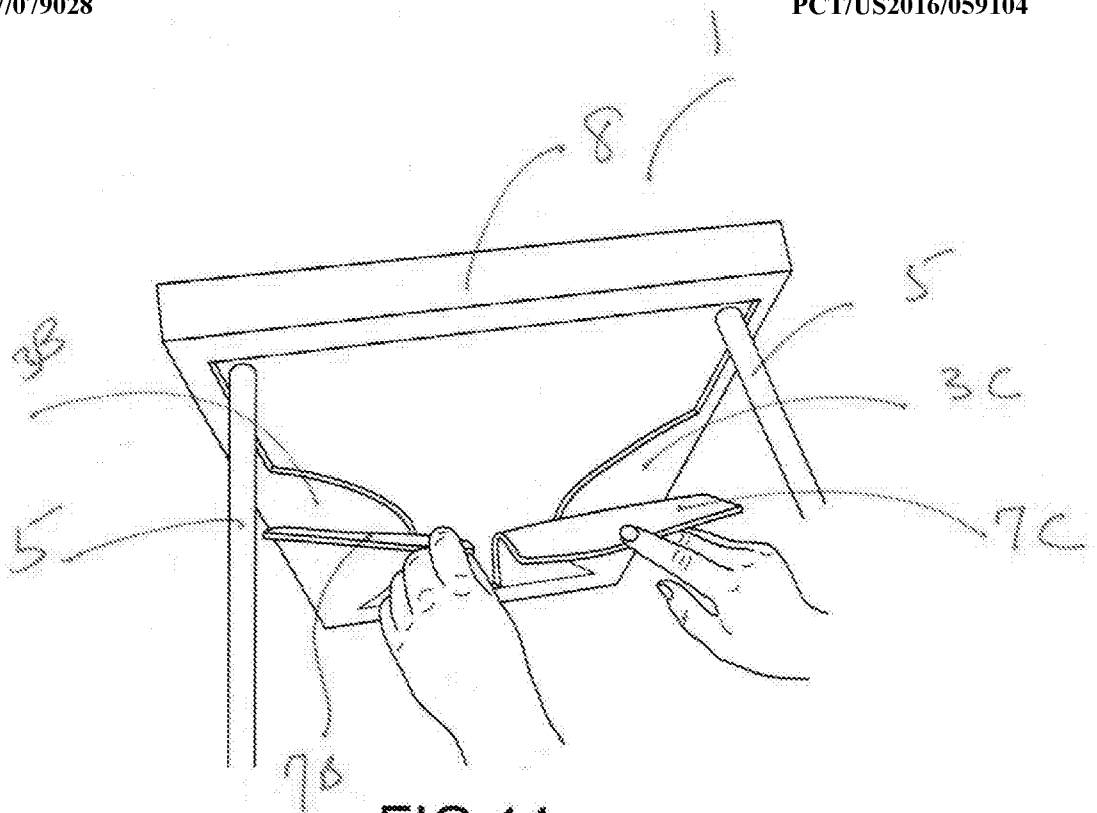

FIG. 10



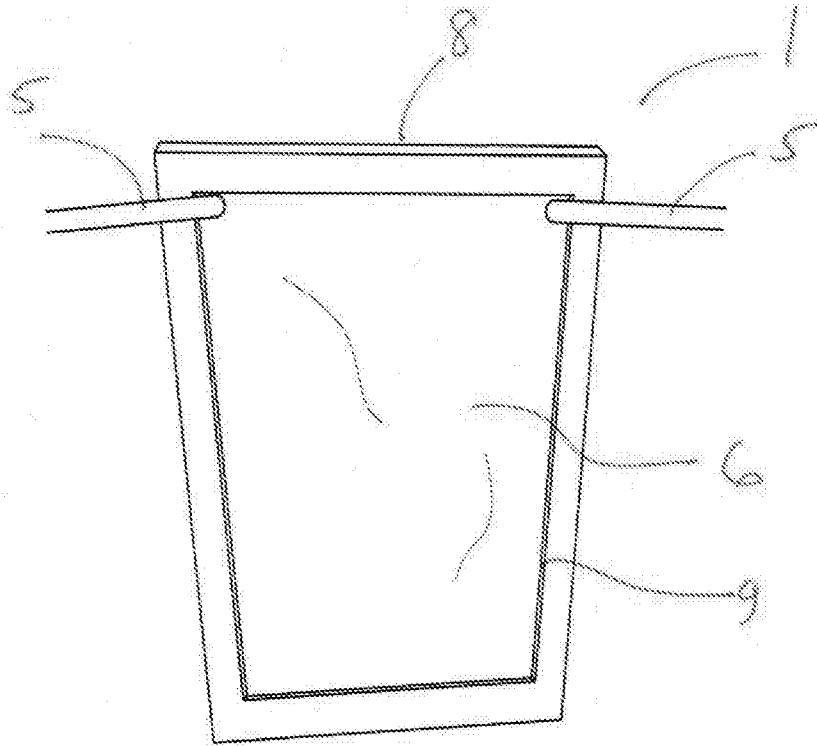

FIG. 13

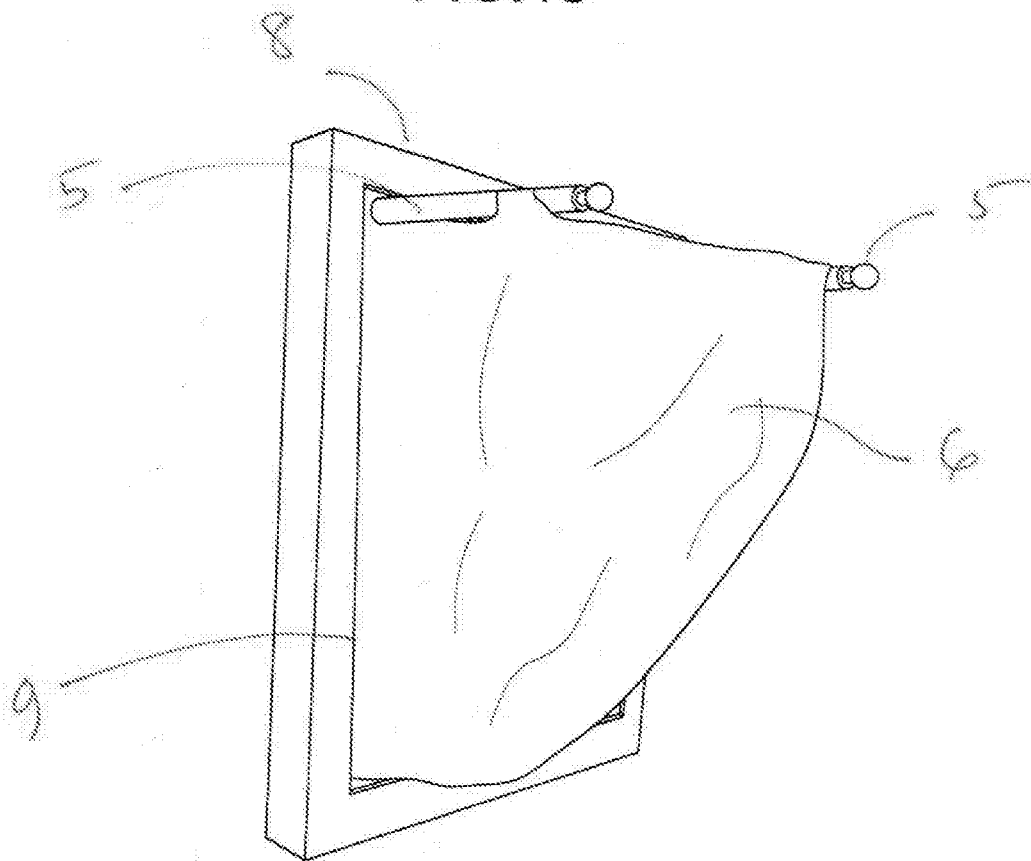

FIG. 14

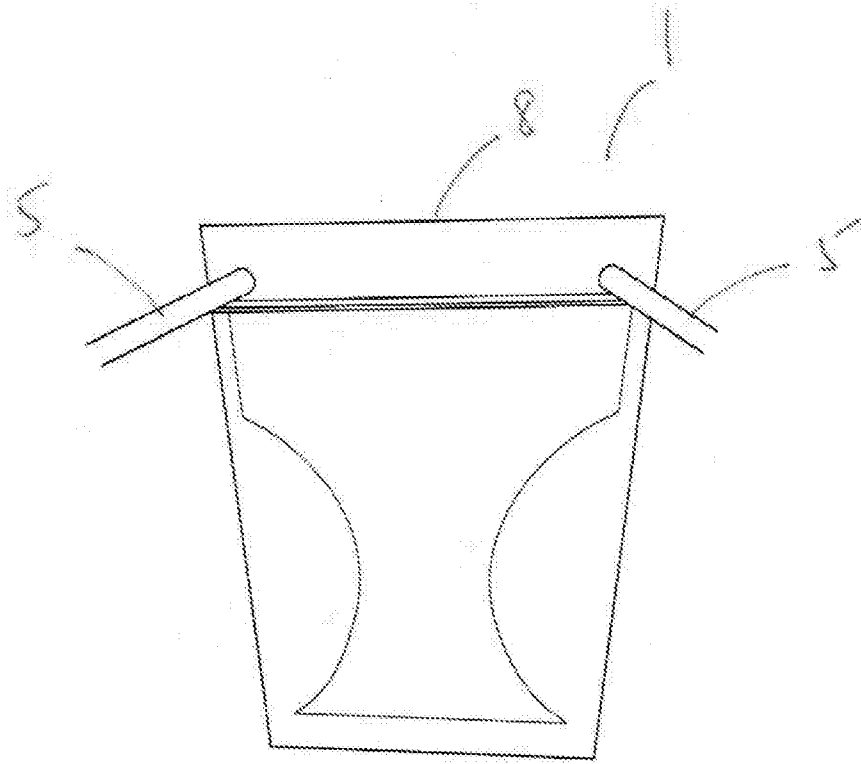

FIG. 15

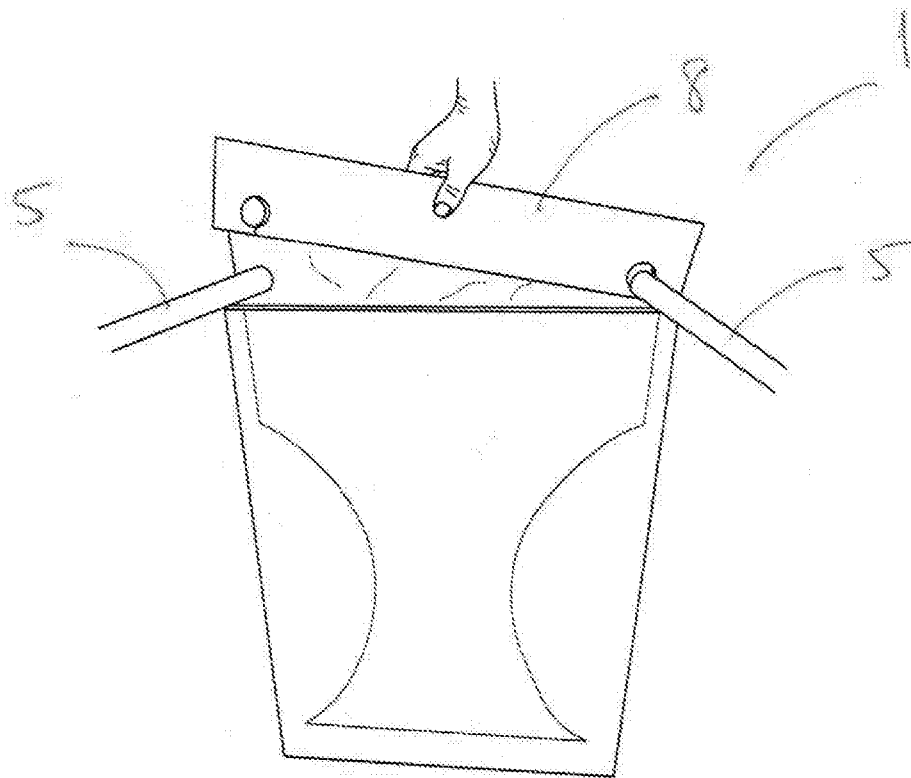

FIG. 16

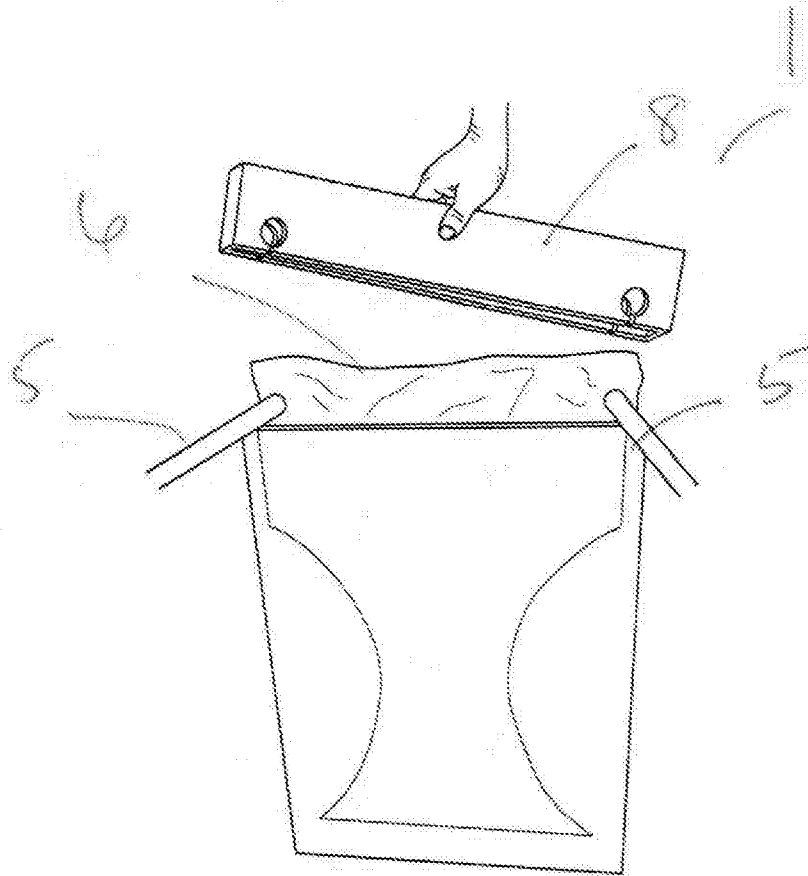

FIG.17

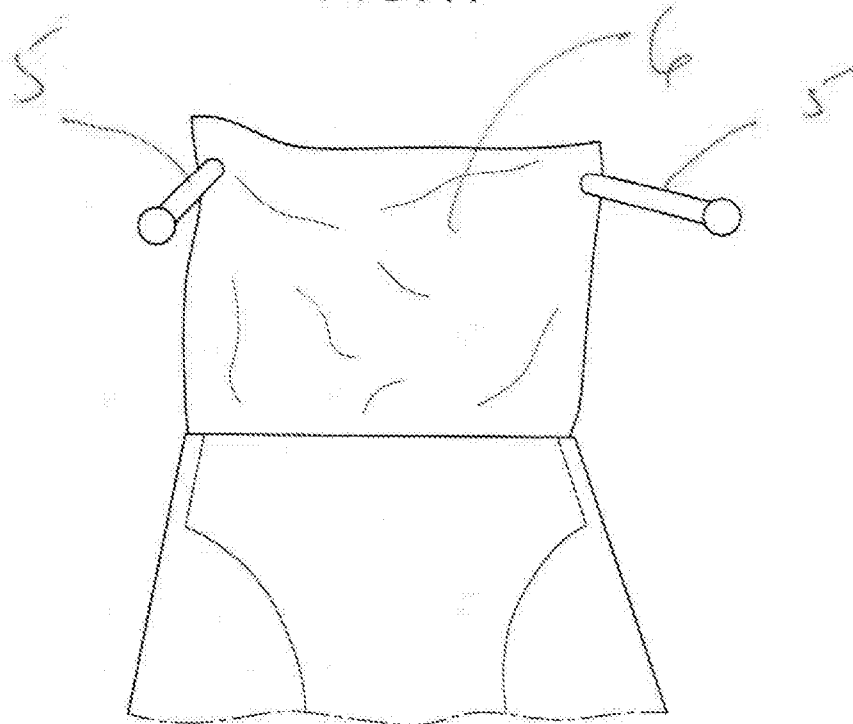

FIG.18



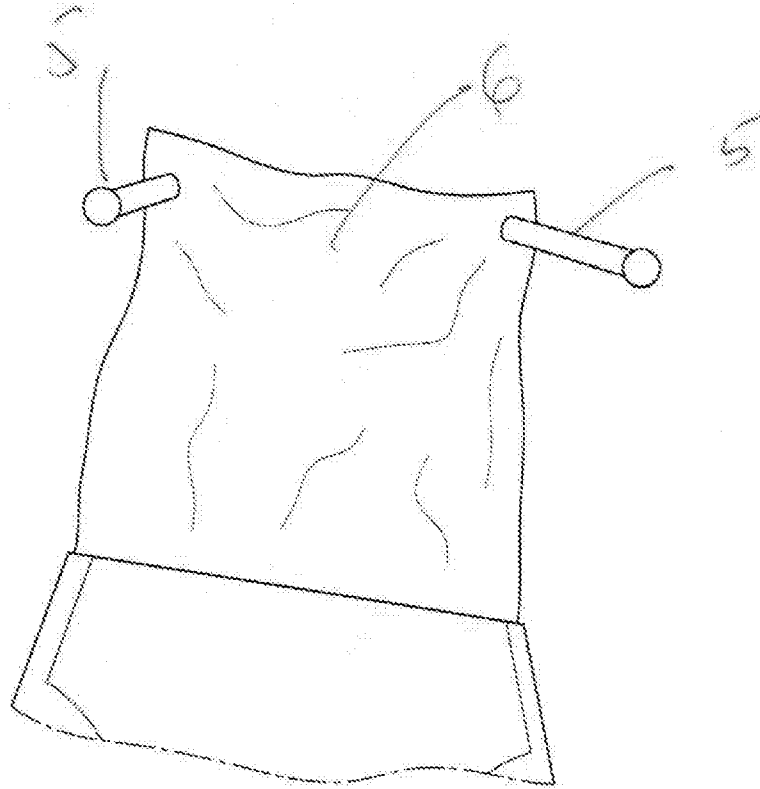

FIG.19

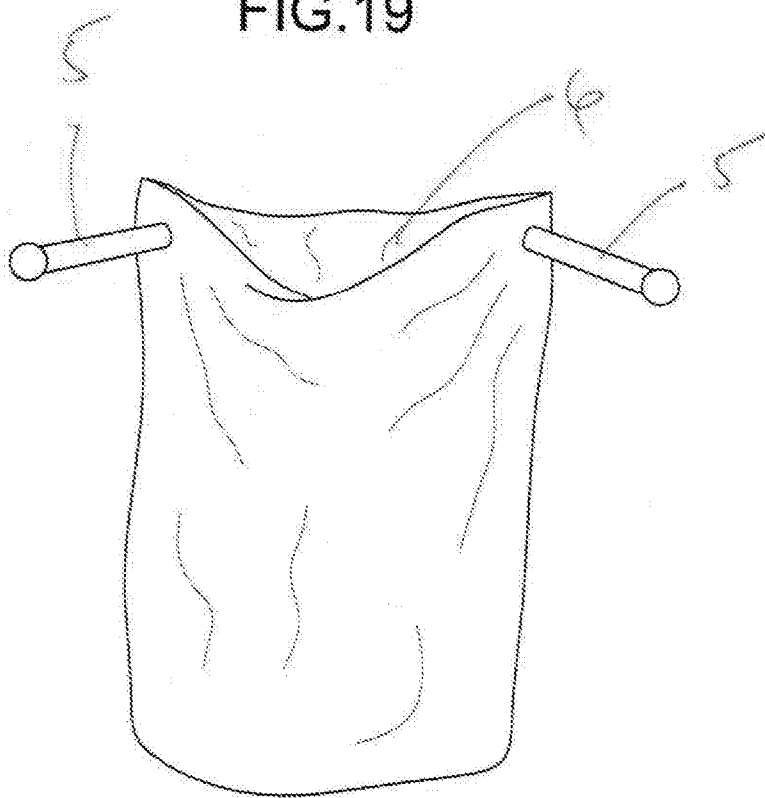

FIG.20

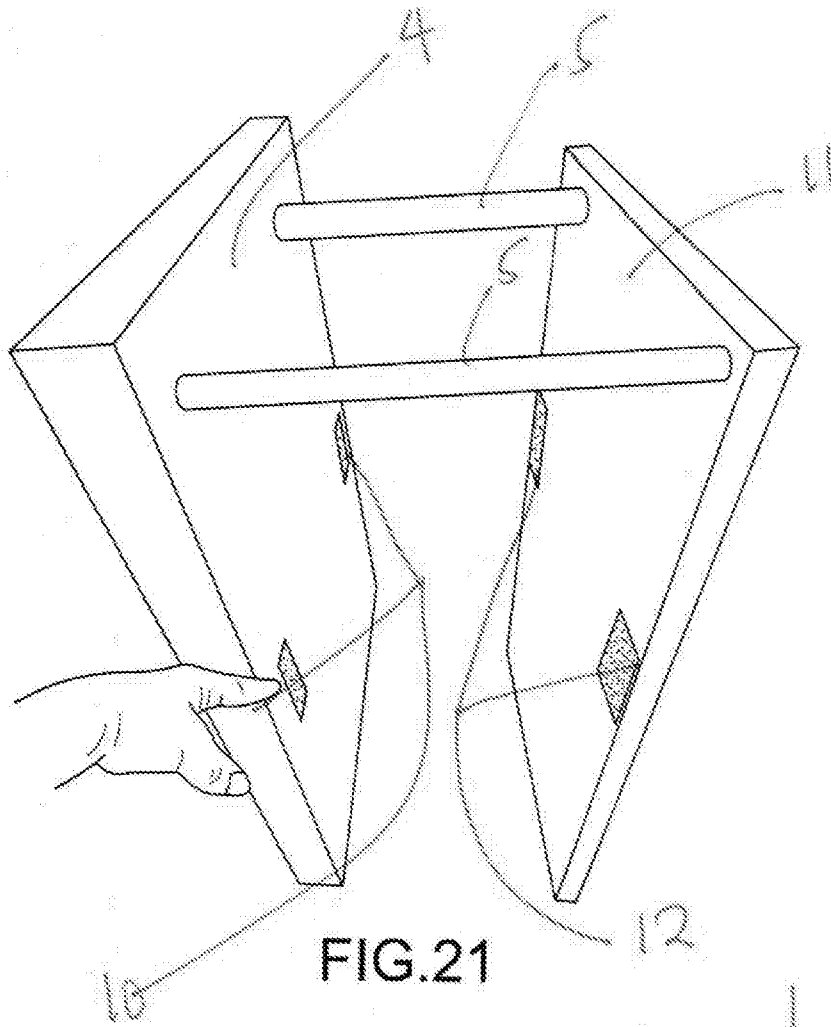

FIG. 21

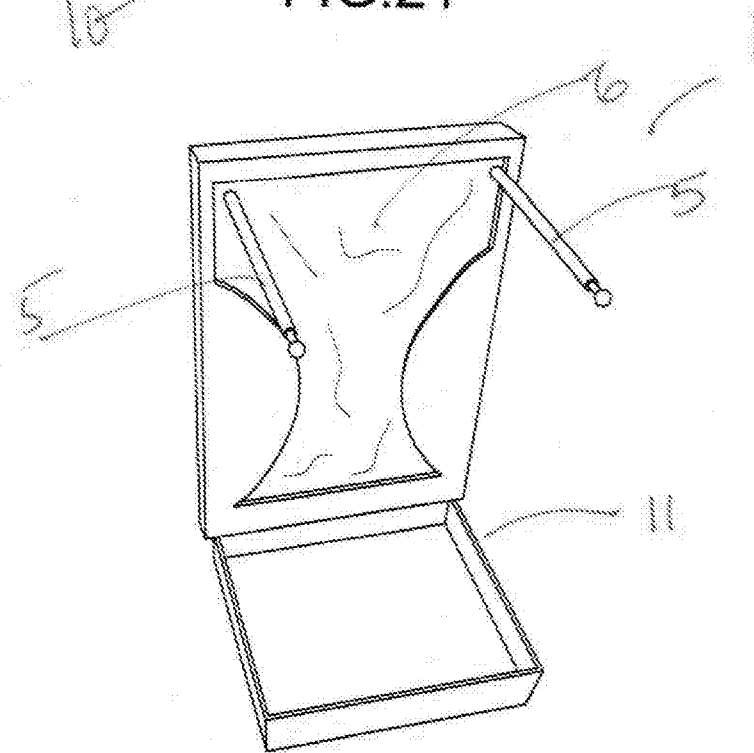

FIG. 22

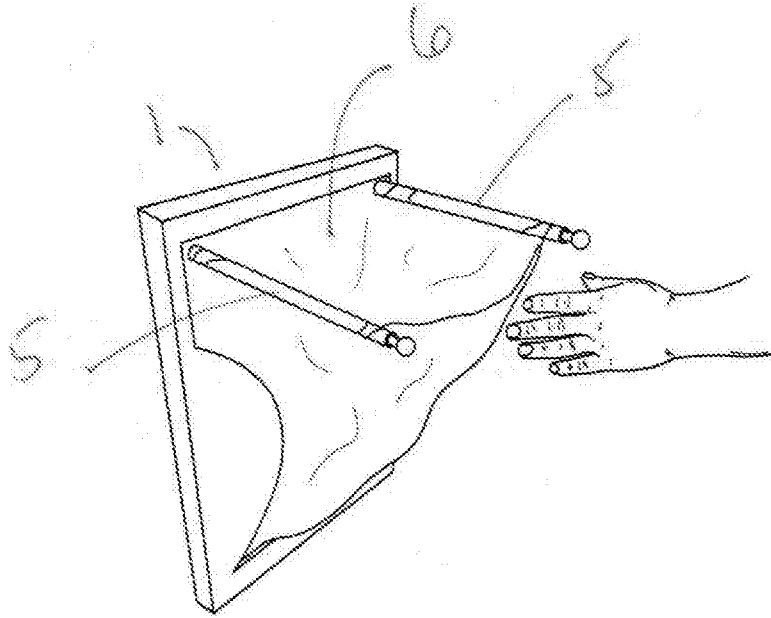

FIG. 23

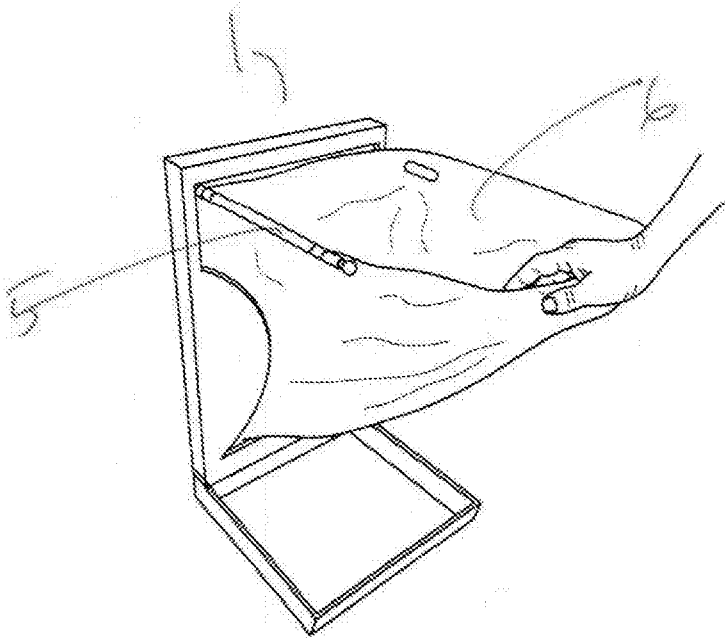

FIG. 24

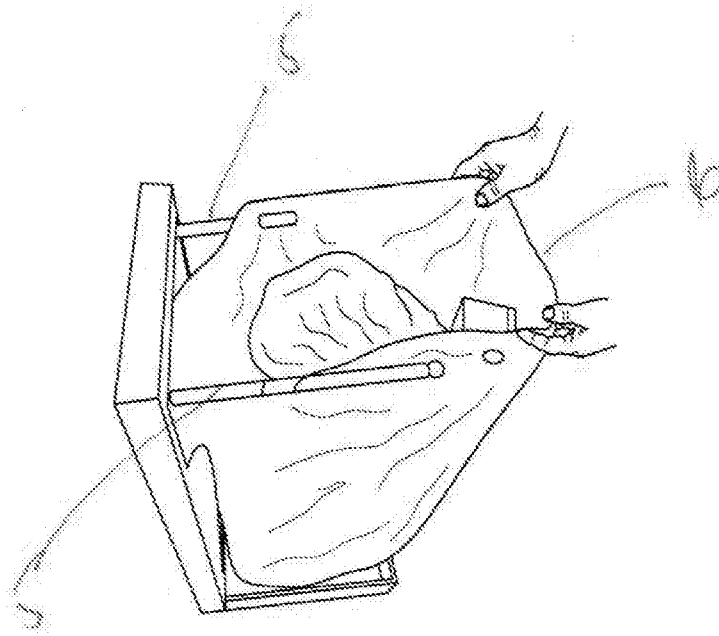

FIG. 25

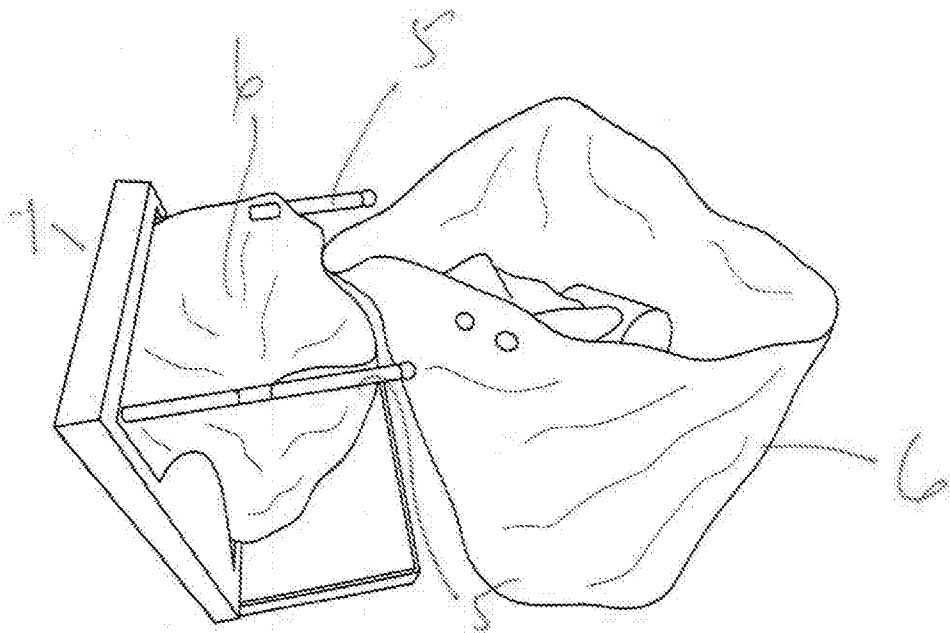

FIG. 26

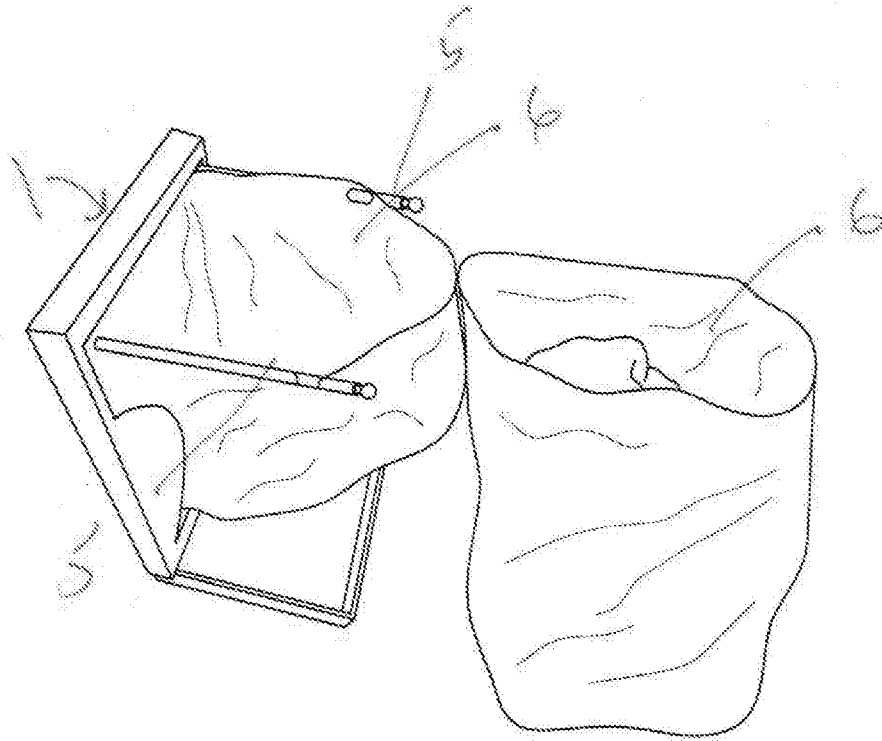

FIG. 27

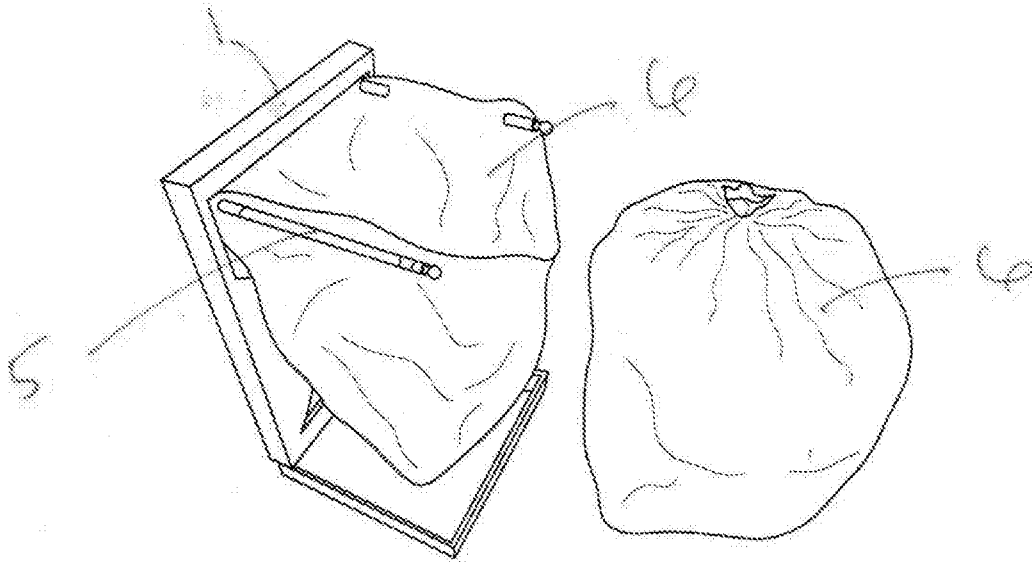

FIG. 28

**A. CLASSIFICATION OF SUBJECT MATTER****B65F 1/14(2006.01)i, B65F 1/00(2006.01)i, B65D 83/08(2006.01)i, B65D 77/30(2006.01)i**

According to International Patent Classification (IPC) or to both national classification and IPC

**B. FIELDS SEARCHED**Minimum documentation searched (classification system followed by classification symbols)  
B65F 1/14; B65B 1/06; B65D 1/34; B65F 1/06; B65D 25/16; B65F 1/00; B65D 83/08; B65D 77/30Documentation searched other than minimum documentation to the extent that such documents are included in the fields searched  
Korean utility models and applications for utility models  
Japanese utility models and applications for utility modelsElectronic data base consulted during the international search (name of data base and, where practicable, search terms used)  
eKOMPASS(KIPO internal) & keywords: trash, garbage, bag, receptacle, dispense, detach, flip, rod**C. DOCUMENTS CONSIDERED TO BE RELEVANT**

Category*	Citation of document, with indication, where appropriate, of the relevant passages	Relevant to claim No.
Y	US 5671847 A (PEDERSEN et al.) 30 September 1997 See column 2, lines 40-67 and figures 1-4.	1-32
Y	KR 10-0462463 B1 (KWON, SUN JUNG) 17 December 2004 See claim 1 and figures 1-3.	1-32
A	US 5183157 A (DARDEN, LOUIS R.) 02 February 1993 See column 2, lines 4-38 and figures 1-5.	1-32
A	KR 10-2014-0136835 A (JEON, WON) 01 December 2014 See paragraphs [0045], [0046] and figure 2.	1-32
A	US 5628424 A (GOLA, STEPHEN G.) 13 May 1997 See column 6, lines 18-37 and figure 1.	1-32

 Further documents are listed in the continuation of Box C. See patent family annex.

\* Special categories of cited documents:

"A" document defining the general state of the art which is not considered to be of particular relevance

"E" earlier application or patent but published on or after the international filing date

"L" document which may throw doubts on priority claim(s) or which is cited to establish the publication date of another citation or other special reason (as specified)

"O" document referring to an oral disclosure, use, exhibition or other means

"P" document published prior to the international filing date but later than the priority date claimed

"T" later document published after the international filing date or priority date and not in conflict with the application but cited to understand the principle or theory underlying the invention

"X" document of particular relevance; the claimed invention cannot be considered novel or cannot be considered to involve an inventive step when the document is taken alone

"Y" document of particular relevance; the claimed invention cannot be considered to involve an inventive step when the document is combined with one or more other such documents, such combination being obvious to a person skilled in the art

"&amp;" document member of the same patent family

Date of the actual completion of the international search

15 February 2017 (15.02.2017)

Date of mailing of the international search report

**15 February 2017 (15.02.2017)**

Name and mailing address of the ISA/KR

International Application Division  
Korean Intellectual Property Office  
189 Cheongsa-ro, Seo-gu, Daejeon, 35208, Republic of Korea

Facsimile No. +82-42-481-8578

Authorized officer

PARK, Tae Wook

Telephone No. +82-42-481-3405



**INTERNATIONAL SEARCH REPORT**

Information on patent family members

International application No.

**PCT/US2016/059104**

Patent document cited in search report	Publication date	Patent family member(s)	Publication date
US 5671847 A	30/09/1997	None	
KR 10-0462463 B1	17/12/2004	None	
US 5183157 A	02/02/1993	None	
KR 10-2014-0136835 A	01/12/2014	KR 10-1484546 B1	20/01/2015
US 5628424 A	13/05/1997	None	