

Sept. 27, 1932.

H. J. GOOSMAN

1,879,191

THROW-OUT FEED LIFT MECHANISM FOR SEWING MACHINES

Filed Nov. 3, 1931

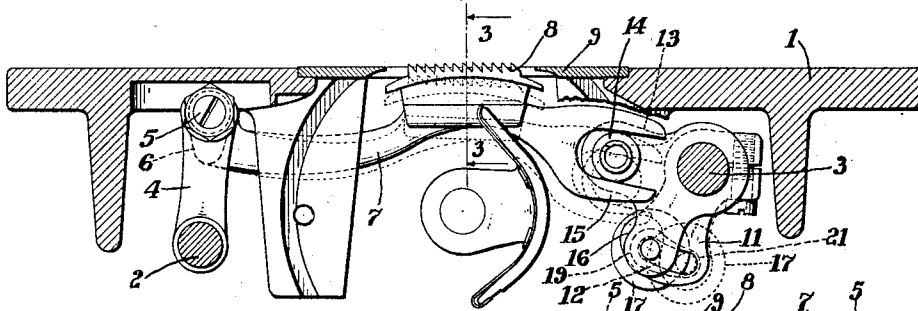

Fig. 1.

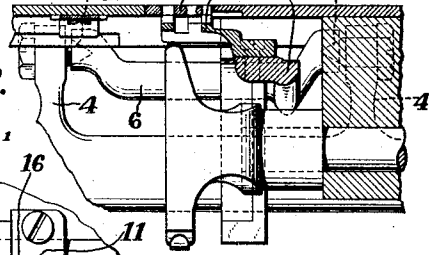

Fig. 3.

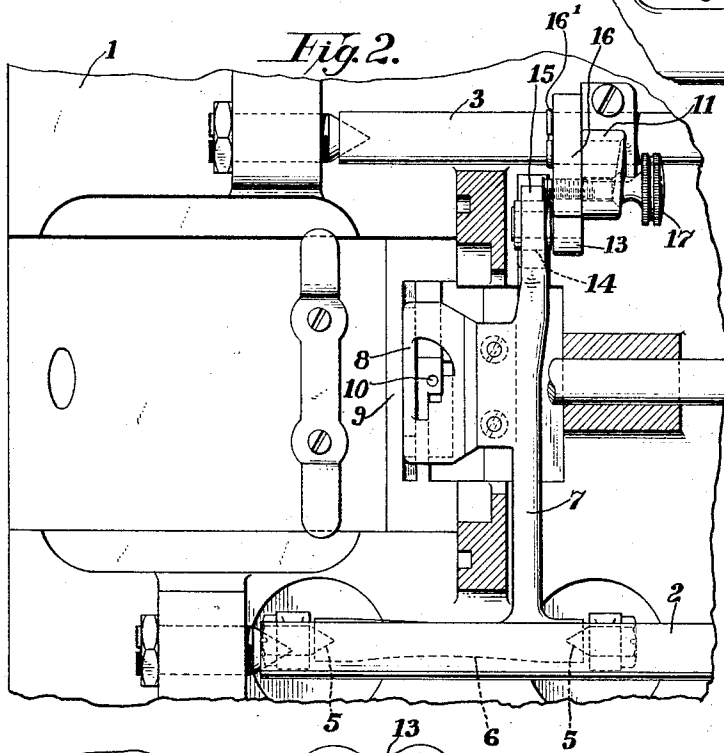

Fig. 2.

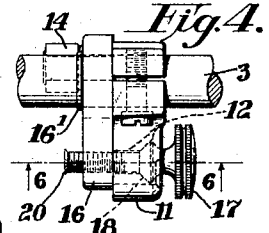

Fig. 4.

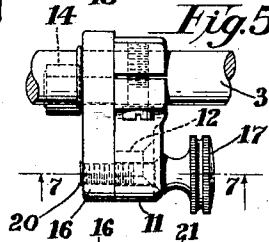

Fig. 5.

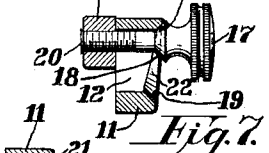

Fig. 6.

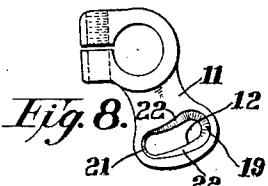

Fig. 8.

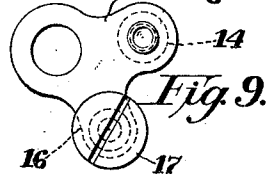

Fig. 9.

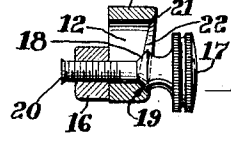

Fig. 7.

Witness:

John H. Cave

Herbert J. Goosman.

By Henry J. Miller

Attorney

# UNITED STATES PATENT OFFICE

HERBERT J. GOOSMAN, OF ELIZABETH, NEW JERSEY, ASSIGNOR TO THE SINGER MANUFACTURING COMPANY, OF ELIZABETH, NEW JERSEY, A CORPORATION OF NEW JERSEY

## THROW-OUT FEED-LIFT MECHANISM FOR SEWING MACHINES

Application filed November 3, 1931. Serial No. 572,828.

For certain operations with household sewing machines, such as embroidering and darning operations, it is desirable to render the usual four-motion feed-dog ineffective so that it will not engage the work. This has heretofore been done in various ways including a provision for uncoupling the feed-bar lifting arm from its actuating rock-shaft.

The present improvement has for an object to provide a simplified means for effecting the disconnection of the feed-bar from the feed-lift mechanism for embroidering and darning operations or the like.

A further object of the invention is to provide for the secure clamping of the shiftable parts in working position, to avoid the evils of lost motion and accidental displacement of the parts.

Still further, the invention has for an object to provide means for insuring or compelling movement of the shiftable parts to normal feeding or working position, when the feed-bar is reconnected to its actuating means, making it impossible for the operator to reconnect or tighten the parts in any other than correct working relation.

The invention comprises the devices, combinations, and arrangements of parts hereinafter set forth and illustrated in the accompanying drawing of a preferred embodiment of the invention, from which the several features of the invention and the advantages attained thereby will be readily understood by those skilled in the art.

Fig. 1 is a transverse vertical section through the bed-plate of the sewing machine showing the feed-bar and associated parts in elevation. Fig. 2 is a bottom plan view of the parts. Fig. 3 is a section through the feed-bar on the line 3—3, Fig. 1, a shuttle-driver being shown in elevation. Fig. 4 is an elevation of the feed-lift throw-out device with parts tightened to connect the feed-lift roller in proper working relation to the feed-lift rock-shaft. Fig. 5 is a similar view with the parts loosened to enable the feed-lift roller to drop relative to the feed-lift rock-shaft. Fig. 6 is a section on the line 6—6, Fig. 4. Fig. 7 is a section on the line 7—7, Fig. 5. Fig. 8 is an elevation of the arm

shown in Figs. 4 and 5 which is fast to the feed-lift rock-shaft and Fig. 9 is an elevation of the arm shown in Figs. 4 and 5 which is loose to the feed-lift rock-shaft.

1 represents the sewing machine bed below which is mounted, in the usual manner, the feed-advancing rock-shaft 2 and feed-lift rock-shaft 3. The feed-advancing rock-shaft 2 is formed with the usual spaced upstanding arms 4, 4 carrying the pintles 5, 5 which pivotally support the transversely extending rearward end-portion 6 of the feed-bar 7 carrying the usual feed-dog 8. The feed-dog 8 works through the usual slotted throat-plate 9, the upper surface of which is substantially flush with the bed or cloth-plate 1 of the machine and is formed with the usual hole 10 through which the reciprocating needle (not shown) descends for cooperation with the oscillatory shuttle (not shown) or other suitable loop-taker.

The feed-lift rock-shaft 3 has fixed to it a feed-lift arm 11 which is formed at its free end with an arcuate slot 12 concentric with the feed-lift rock-shaft 3. Freely mounted on the feed-lift rock-shaft 3 alongside the arm 11 is a bell-crank lever the horizontal arm 13 of which carries the feed-lift roller 14 embraced by the fork 15 at the forward free end of the feed-bar. A snap-ring 16 resiliently seated in a groove alongside the bell-crank lever 13, 16 acts as a collar to prevent creepage of the lever 13, 16 away from the arm 11. The depending arm 16 of the bell-crank lever has threaded into it a manually operated clamp-screw 17 having at the base of its head a conical shoulder 18 adapted to be seated in the relatively deep semi-circular conical depression 19 at the right-hand end of the slot 12, Fig. 8, in the feed-lift arm 11. In this clamped or seated position of parts, as shown in Figs. 4 and 6, and full lines in Fig. 1, the feed-bar is in elevated or working position and is normally related to the feed-lift rock-shaft 3 for the usual feeding action.

When it is desired to use the sewing machine for embroidering or like operations, the operator loosens the screw 17 as far as it will go or until the flared end 20 of the

screw 17 binds against the arm 16, as shown in Figs. 5 and 7. When the screw 17 is so loosened, the arm 16 is disconnected from the feed-lift arm 11, and the feed-bar 7 and bell-crank lever 13, 16 drop to their respective dotted line positions, Fig. 1. In the dropped position of the feed-bar, its teeth are at all times below the surface of the throat-plate 9 and hence it has no action upon the work.

The screw 17 now occupies the opposite end of the slot 12 in the arm 11 and the conical shoulder 18 is in or near engagement with the relatively shallow semi-circular conical depression 21. It will be observed from Figs. 7 and 8, that the arm 11 is thicker at the end of the slot 12 having the shallow conical depression 21 than it is at the opposite end of the slot 12 having the deep conical depression 19. It will also be observed that the two conical depressions 21 and 19 at the opposite ends of the slot 12 are connected by gradually sloping inclined walls 22, so that when the screw 17 is tightened, such screw and the arm 16 are forced to move down the inclines 22 to the position shown in Fig. 6 wherein the screw 17, when fully tightened, is seated in feeding position at the end of the slot 12 having the deep semi-circular conical depression 19. It is thus impossible to tighten the screw 17 in any other than correct working position relative to the feed-lift arm 11. The parts, when tightened, are rigidly clamped together and can never shake or rattle from lost motion.

Having thus set forth the nature of the invention, what I claim herein is:—

1. In feeding mechanism for sewing machines, a feed-advance rock-shaft, a feed-lift rock-shaft, a feed-bar connected to said feed-advance rock-shaft, a feed-lift arm fixed to said feed-lift rock-shaft, an arm loose on said feed-lift rock-shaft and connected to lift said feed-bar, and a screw and slot clamping connection between said arms permitting the feed-bar to be dropped when said screw is loosened, said slot having a sunken seat at one end for said screw.

2. In feeding mechanism for sewing machines, a feed-advance rock-shaft, a feed-lift rock-shaft, a feed-bar connected to said feed-advance rock-shaft, a feed-lift arm fixed to said feed-lift rock-shaft, an arm loose on said feed-lift rock-shaft and connected to lift said feed-bar, and a screw and slot connection between said arms permitting the feed-bar to be dropped when said screw is loosened, the slotted arm being tapered in thickness from one end of said slot to the other, so that when said screw is tightened it is forced along said slot by a wedging action to raise the feed-bar to normal working position.

3. In feeding mechanism for sewing machines, a feed-advance rock-shaft, a feed-lift rock-shaft, a feed-bar connected to said feed-advance rock-shaft, a feed-lift arm fixed to

said feed-lift rock-shaft, an arm loose on said feed-lift rock-shaft and connected to lift said feed-bar, and a screw and slot connection between said arms permitting the feed-bar to be dropped when said screw is loosened, the slotted arm being formed at one end of the slot with a depression, said arm being also formed along the sides of said slot with tapering walls leading to said depression, and said screw having a tapered shoulder adapted to wedge along said tapering walls toward and finally seat in said depression at one end of said slot, in which position the feed-bar is raised to normal working position.

4. In feeding mechanism for sewing machines, a feed-advance rock-shaft, a feed-lift rock-shaft, a feed-bar connected to said feed-advance rock-shaft, a feed-lift arm fixed to said feed-lift rock-shaft, an arm loose on said feed-lift rock-shaft and connected to lift said feed-bar, and a screw and slot connection between said arms permitting the feed-bar to be dropped when said screw is loosened, the slotted arm being formed at one end of the slot with a shallow depression and at the other end of said slot with a deep depression, said depressions being connected together by tapering walls, and said screw having a tapered shoulder adapted to wedge along said tapering walls toward and finally seat in said deep depression, in which position the feed-bar is raised to normal working position.

In testimony whereof I have signed my name to this specification.

HERBERT J. GOOSMAN.