

P. A. B. TRIACEA.

Improvement in Dovetailing-Machines.

No. 130,548.

Patented Aug. 13, 1872.

Fig. 3

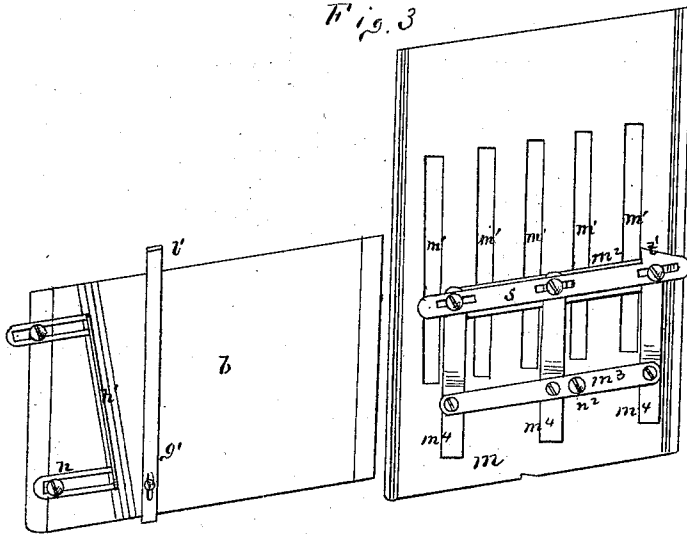

Fig. 4

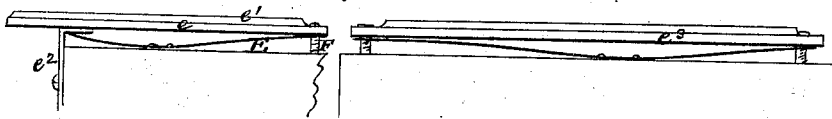
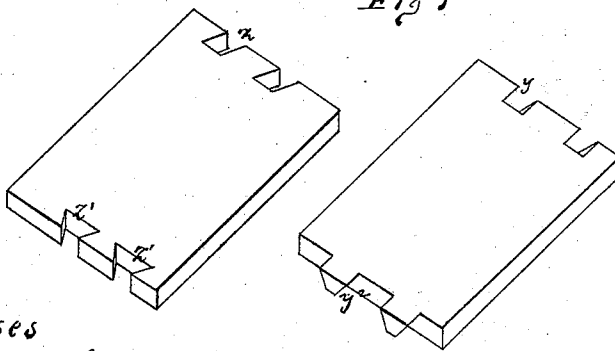

Fig. 5



Witnesses

Geo. Upham.

A. J. Kane.

Inventor

Peter A. B. Triacea

by F. A. Conwell

his Atty

UNITED STATES PATENT OFFICE.

PETER A. B. TRIACCA, OF STAMFORD, CONNECTICUT.

IMPROVEMENT IN DOVETAILING-MACHINES.

Specification forming part of Letters Patent No. 130,548, dated August 13, 1872.

To all whom it may concern:

Be it known that I, PETER A. B. TRIACCA, of Stamford, in the county of Fairfield and State of Connecticut, have invented a Dovetailing-Machine, of which the following is a specification:

In the accompanying drawing, Figure 1 is a plan view of my invention. Fig. 2 is an end view. Figs. 3 and 4 are detail views, and Fig. 5 is a representation in perspective, of boards operated upon by my improved dovetailing machine.

This invention has relation to machines for cutting dovetails in wood; and it consists in the construction and novel arrangement of stationary and adjustable saws, movable tables or carriages, adjustable ways or slides, and adjustable gages appertaining to a machine capable of producing the corresponding dovetails, tongues, and notches for various kinds of dovetailed joints, all substantially as hereinafter more fully described.

Referring to the accompanying drawing, *a* represents the main frame of the machine embodying my improvements. Upon the upper part of this frame are supported the stationary bench-tables *b*, and the adjustable table composed of the parallel bars *c d*. The table *b* is constructed with a series of parallel slots, *a*², arranged obliquely. Above these slots, and with their bearings in boxes or standards *l*, resting on the partitions of said slots, are arranged a series of stationary wide-edged beveled saws, *j*. These saws stand in an oblique row, but with their axes at right angles to the parallel sides of the table *b* and their faces parallel with the sides of said table and with each other. *e e* designate parallel ways, having central flanges *e*¹ on their upper sides, fitting grooves in the under side of a movable table or carriage, *b'*. These ways are supported by the slotted adjustable L-shaped standards *e*², which are secured to the front end of the table *b*, and by the curved springs *E*, Fig. 4. Screws *F* connect said ways at their inner ends to the table *b*, but are not rigidly secured to them. The ways may, by means of the standards *e*² and screws *F*, be adjusted to any desired height. The springs assist the work of raising the ways, and also counteract

the evil effects of strain upon the table from any cause whatever. The standards *e*² may be dispensed with altogether, and the ways supported by means of the springs alone, as shown at *e*³, Fig. 4. The table or carriage *b'* is of a rhomboidal form, the sides coinciding with those of the bench *b*, and the front and hind edges running parallel with the row of saws. The board in which are to be cut the dovetail recesses for one part of a joint is carried to and from the saws upon the carriage *b'*. This board is arranged upon the carriage with its edge projecting over the edge of the carriage adjacent to the saws, and with said edge parallel to that of the carriage. An adjustable gage, *g'*, with a finger at *i'*, traverses the carriage and gages the distance to which the board is to project.

Another gage, consisting of two slotted bars, *h*, connected by means of a flange, *h'*, and secured to one side of the carriage by screws, regulates the position of the board with respect to the sides of the table or carriage *b'*. The movement of the carriage itself is arrested at the proper point by means of a stop-block, *i*, secured to the table *b*, as shown. This block prevents the board from being cut too deeply, and also prevents the carriage from being injured at the same time by coming in contact with the saws.

The beveled saws *j* are designed for use in cutting out the dovetails proper for one part of a joint, the sides of these dovetails being at right angles to the surface of the board on which they are formed.

In making said dovetails the board, of a rectangular form, is laid on the carriage *b'* and properly gaged, after which the carriage, with the board, is moved toward the saws, the latter being in motion, and one-half of each dovetail formed, the saws cutting each an oblique parallel-sided slot, as shown at *z* in Fig. 5 of the drawing. The carriage is then moved back, and the board inverted, after which they are again moved toward the saws, and the dovetails *z'* completed. The other end of the board may be then turned toward the saws and similar dovetails produced in the manner described. Upon one face of each saw, or secured to the saw-arbor, is a grooved pulley, *k*,

over which passes a belt from a main driving-shaft having other pulleys. Through the medium of said pulleys and belts the saws are operated from the driving-shaft.

As before stated, the table *c d* is composed of the parallel bars designated by these letters. These bars are arranged between the inner edge of the table *b* and the topmost transverse beam of the frame *a*; but they may, if desirable, be arranged in any other suitable position. The bars *c d* are connected together by means of a horizontal lever, *D*, which is pivoted to them. The bar *d* is rigidly secured to the frame by means of a bar, *d'*, while the bars *c* are adjustable lengthwise, and capable of being all simultaneously moved through the operation of the lever-connection *D*. Through the middle part of each bar *c d* a slot, *p*, is made, and within said slot a wide-edged saw, *n*, arranged with its shaft journaled to the side walls of the slot, and provided with a grooved pulley or belt-wheel, *o*, to receive a belt from a corresponding pulley on the main driving-shaft. The slots *p* and saws *n*, it will be perceived, lie in a row, having the same or a similar oblique relation to the sides of the table *c d* as the slots and saws of the table *b* have to the latter. The table *c d* is provided also with a carriage, *m*, of a rhomboidal or equivalent form, supported and movable upon parallel guides or ways *e*³, of almost substantially the same construction and arrangement as the ways *e*. The standards *e*² are, however, dispensed with, the ways made longer than those marked *e*, and adjustable at both ends by means of adjusting-screws *e*⁵. The carriage *m* is slotted lengthwise, as shown at *m*¹, to let the upper parts of the saws *n* pass through to reach the wood, and is provided with a support and gage for the board, consisting of the three standards *r r r*, connected together by means of pivoted bars *m*² *m*³, the former being arranged within recesses or slots cut in the front parts of said standards, and the latter secured to the foot-extensions *m*⁴ at the back and lower parts of the same. This gage is attached to the carriage by means of studs *n*¹ projecting from the bottom parts of the two outer standards *r*, and entering holes in the carriage, and, by means of a screw or bolt, *n*², passing through the bar *m*³ and into the carriage, as shown. Upon the tops of the standards *r* is a lateral gage, *s*, having longitudinal slots through which screws *t* pass, and provided with a shoulder, *t'*, for the board to rest against while being sawed. The saws *n* are employed in cutting the beveled tongues and intervening slots to fit the slots and dovetails of the board cut by the other saws when both boards are brought together at a right angle. The sides of said tongues, it will be seen by reference to *s'*, Fig. 5, lie obliquely to the surfaces of the boards.

To produce these tongues two operations

are required. In the first place, the gage being arranged with its front portion on a line with the row of saws, as shown in Fig. 3, the board is placed upon the carriage in an upright position, one surface against the gage, and its outer edge behind the shoulder *t'* of the lateral gage. The carriage and board are then moved toward the saws, and the slots *y*, Fig. 5, having parallel sides oblique with respect to the surface of the board produced. The board is now removed, the bars *c c* shifted by moving the lever *D* toward the saws, the gage removed, the carriage inserted, and the gage and board replaced. The board is then brought in contact with the saws and the tongues completed, as shown at *y*².

In arranging the gage for the second operation, the standards *r* must be shifted so as to bring the front part of the gage on a line parallel to the varied line of the saws. Bent plates *g*, secured to the ends of the bar *d*, limit the travel of the carriage.

The lever *D* has a hole bored near its outer end to receive the pins *a*¹ *a*², which hold said lever in position when it is shifted. A spring, *A*, with holes to let said pins pass through, rests on and prevents the lever from rising off the pins. The end of said spring is bent down at the end of the table, and is secured by a removable pin, *x*. The spring *A* is to be raised whenever it is necessary to shift the lever.

The bars *c d*, saws, &c., need not be shifted every time a board is cut. A large number of boards may be put through the first operation, and then the parts changed for the second. This machine is so constructed that two persons may operate at the same time.

Having fully described my invention, what I claim as new, and desire to secure by Letters Patent, is—

1. The dovetailing or mortising machine, having a series of beveled saws *j* with broad edges, and arranged obliquely and independently of each other, substantially as and for the purpose specified.

2. The movable table or carriage *b'*, having one or more oblique sides, and provided with the adjustable gages *h h'* and *g'*, constructed and arranged as described, in combination with the obliquely-arranged saws *j* and the ways *e*, constructed substantially as and for the purpose described.

3. The adjustable carriage-ways *e*, supported by the springs *E* and adjustable standards *e*², substantially as specified.

4. The combination of the vertically-adjustable saw-carriage ways with springs *E*, substantially as and for the purpose specified.

5. The saw-table, composed of the longitudinally-adjustable bars *c c* and stationary bar *d* holding the saws *n*, substantially as specified.

6. The invertible carriage *m*, provided with adjustable transferable gage *r*, obliquely arranged, substantially as specified.

7. The carriage *m*, having the oblique gage *h* holding the lateral gage *s*, in combination with the oblique row of saws *n*, substantially as specified.

8. The perforated lever *D*, in combination with the shiftable bars *c*, perforated plate *A*, and pins *a*¹ *a*², substantially as described.

In testimony that I claim the above as my invention I have hereunto subscribed my name in the presence of two witnesses.

PETER A. B. TRIACCA.

Witnesses:

ANDREW P. MALONE,
DENIS S. CRONIN.